

April 29, 2013

This manual is a guidance to standardize CDOT sign layout practices. CDOT standards are based upon the Manual on Uniform Traffic Control Devices (MUTCD) and Standard Highway Signs Book. This manual is to be used in conjunction with the Standard Highway Signs (SHS) Design Guidelines and is intended to replace pages 8-1 through 8-3 of the SHS, located at the following link: <http://mutcd.fhwa.dot.gov/SHSe/Design.pdf>

CDOT Sign Shop capabilities are also explained for guidance on special signing issues.

Introduction

This manual summarizes the guidelines that CDOT uses to assure conformity and constructability when designing non-standard signs. The CDOT sign library contains examples of all the types of signs discussed in this manual. In general it is our intent to include sufficient coverage in the sign library that the designer should be able to use the examples as templates for nearly any sign. Designers are encouraged to submit any cases to the HQ Traffic Engineering Section where a suitable template was not found, so that the appropriate addition may be made to the library. There is also some discussion about structural considerations

General Sign Design Guidelines

I. General

There are general guidelines to follow in the design of highway signs in order to conform to basic standards. Many of these guidelines are mentioned in various sections of the MUTCD, while others are derived from accepted practice in sign design and layout. Highway signs with standardized designs conforming to the general guidelines (like most regulatory, warning, emergency management, school, railroad-highway grade crossing, and bicycle signs), are contained in this book, and are shown with different standard sizes depending on the type of highway or facility where the sign is intended to be used.

Although some guide signs also have been standardized and are included in this manual, most guide signs need to be designed separately because of the different messages or legends. For most guide signs, there can be no rigid standardized sizes.

II. Panel Height and Width:

Message variability controls overall sign dimensions. Whenever practical, the overall dimensions of the sign plates should be in multiples of six (6) inches. Any sign panel dimension over four (4) feet should be rounded to the nearest foot.

If a sign layout results in a panel height that is 13' or 14' high, attempt to redesign it so that it is 12' high. Sign sheeting comes in 12' pieces, so there is a significant inefficiency in fabrication costs when that height is exceeded by a small amount.

Using a smaller-than-nominal size panel for the four types of roadway signs may sometimes be justified. For instance, a sign mounted over a particular roadway lane to which the sign applies to may have to be limited in width to the roadway lane width. In some cases, vertical clearances may limit the vertical dimension of the sign. On the other hand, a larger than “nominal” sign may be desirable where greater legibility or emphases is needed. When a variation in the “standard” size is necessary, a reduced or enlarged (as the case may be) letter height, interline, and edge spacing may be used but should be as nearly comparable to standards as possible.

III. Placement of Text and Objects (Spacing):

Guide Sign text must be centered (horizontally and vertically) on the sign panel to achieve a good appearance. Where arrows, route markers or other objects are closer to the sign border than text, the virtual box that contains all of the sign objects should be centered. In other words, the smallest distance from any object on the sign panel from the left edge of the sign should equal the smallest distance from any object to the right edge, and similarly for the top and bottom edges.

Interline spacing should be, at minimum, approximately three-fourths the average of capital or uppercase letter heights in adjacent lines of letters.

The spacing to the top and bottom borders should be approximately equal to the average of the letter height of the adjacent line of letters. The lateral spacing to the vertical borders should be the same as the height of the largest letter.

Spacing between words, words and arrow, a letter and arrow, or a word and number in a line copy should be approximately 1 to 1½ times the upper case letter height used in that line of copy.

When there are supplemental panels or distinctly colored backgrounds on a single panel, the text should be centered within the section. The most common example would be for “Exit Only” sections on Pull-Through signs.

The minimum spacing from an arrow to the sign border shall be 4”.

All aluminum sheeting readily available to the CDOT Sign Shop comes in 12-foot lengths and the following widths:

- .125” thickness - 36” or 48” widths
- .100” thickness - 30”, 36”, 48”, 60” widths
- .080” thickness - 30”, 36”, 48” widths

IV. Text Formatting:

The font on Guide signs should generally be “E” for words that are all upper case letters and “E-Modified” (EM) for upper and lower case letters. The only exception is that the lettering for Exit panels on overhead signs uses 12” “D” font. This is reflected in the examples in the Sign Library. Tables 2E-2 through 2E-5 of the 2009 MUTCD provide detailed guidance for sizes of letters and other objects on guide signs.

For guide signs on expressways and freeways, the prescribed numeral and letter sizes, according to interchange classification and component of sign legend, appear in Tables 2E-1 through 2E-4 of the 2009 MUTCD. The minimum sizes specified should be exceeded where conditions indicate a need for greater legibility.

All names of places, streets and highways on freeway and expressway guide signs shall use lower-case letters with initial upper-case letters (E-Modified font). See Section 2E.14 of the 2009 MUTCD for more details.

For lettering on post-mounted street name signs, MUTCD Section 2D.43 recommends upper and lower case lettering, with the minimum upper case lettering height of 6 inches, and the minimum lower case lettering height of 4.5”.

An accepted “rule-of-thumb” to follow for legibility of signs, other than interstates, is to have one (1) inch of letter height for every 30 feet of desired legibility.

E-Modified series font sizes used are 6”, 8”, 10.67”, 13.33”, 16” and 20”. Twenty inches is the maximum letter height for E-Modified to be used on Colorado Signs.

E-series font sizes used are 4”, 6”, 8”, 10”, 12”, 15”, and 18”. The CDOT Sign shop has a complete stock of pre-cut 6” E series font at all times. All other font sizes must be cut per order, so it is economical to use 6” E legends when possible.

Kerning (reduced letter spacing) **should be avoided**, as it makes sign fabrication more difficult and can reduce the legibility of the sign. The only time kerning might be justified is when the required text cannot be made to fit on the maximum allowable panel size by any other layout modifications. If kerning must be applied, it should only be applied to the text that needs to be shortened, not to all of the sign text, and the degree of kerning should be as slight as possible. Use of kerning is considered to be a design variance and must be documented in the project file.

V. History and Guidance on Font Usage:

CDOT has adopted the 1977 Federal font standard for all of its fonts. A 2000 series font exists but has not yet been adopted by Colorado.

Previously, Colorado has employed special Colorado Modified fonts that used wider letter strokes. Other non-standard font styles have previously been used by Colorado for reasons of practicality. The designer should not be confused by any remnant documentation that might reference these obsolete styles. Currently, only the standard Federal fonts are acceptable and are the only ones that are used in the Sign Library examples.

VI. Borders and Corner Radii:

The corners of all sign borders shall be rounded, and (where practical) the corners of the sign panels should also be rounded to conform to the border, except for STOP signs. On guide signs, the corner radii of sign borders should be approximately one-eighth ($\frac{1}{8}$) of the lesser side dimension, except that the radii should not exceed 12 inches on any sign. The area outside the corner radius on large guide signs may need to be trimmed.

With few exceptions, the MUTCD requires all signs to have a border of the same color as the legend. A dark border should be set in from the edge, while a white border should extend to the edge of the panel.

A suitable border for 30-inch signs with a light background should be from one-half (½) to one (1) inch in width, one-half (½) inch from the edge. For similar signs with a white border, a width of one (1) inch is appropriate. For other signs, the border widths should be of similar proportions but should not exceed the stroke width of the major lettering of the sign. For guide signs smaller than six (6) feet by 10 feet, a border width of approximately one and a quarter (1¼) inch may be used; for those guide signs exceeding six (6) feet by 10 feet, the border width should be two (2) inches; and for unusually large guide signs, a border width of three (3) inches may be appropriate.

For double border signs, the following guidelines may be used to determine border and corner specifications:

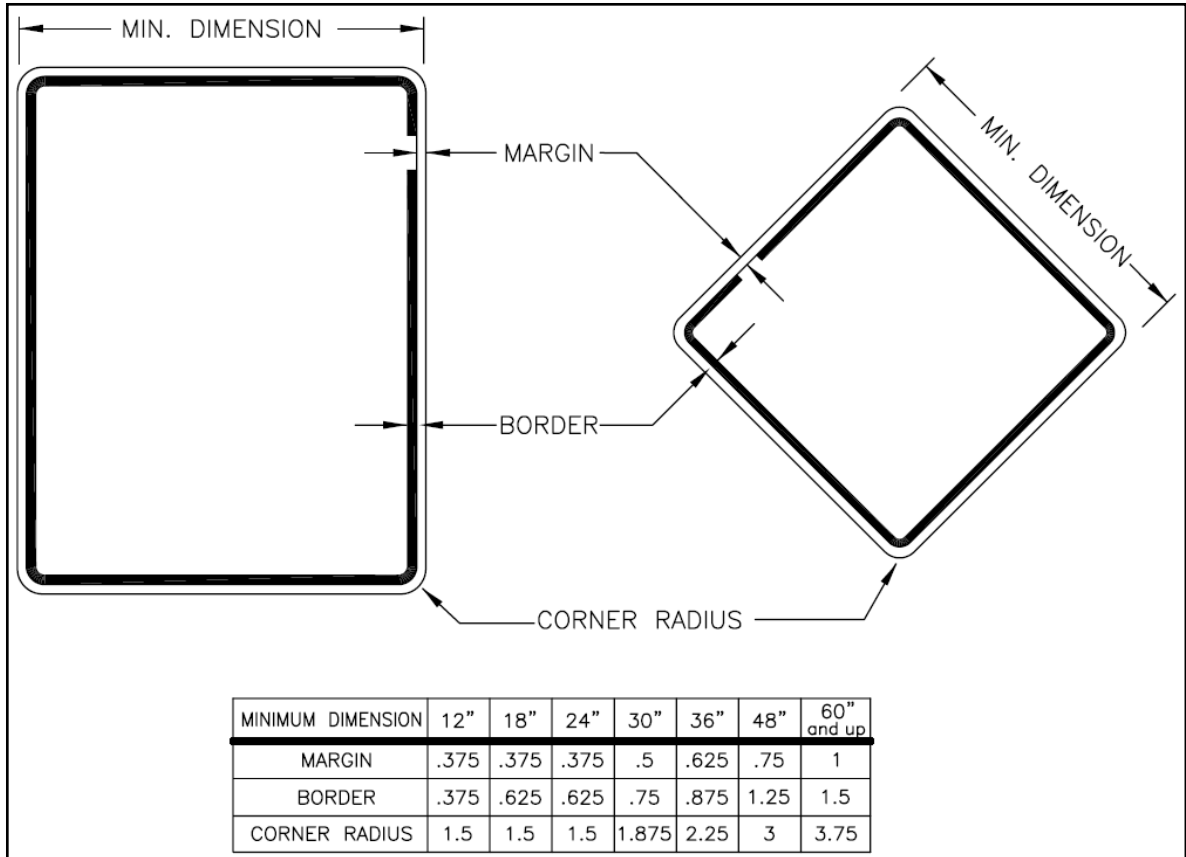

VII. Symbols and Graphics:

In general, you should use “.dxf” files (typically created using Microstation) for placing graphics into sign layouts.

When it is necessary to design special graphical symbols for signs, the following considerations should be taken.

- The maximum size symbol the Sign Shop cutter can handle is 39” x 48”. Anything larger than this must be done in smaller sub-sections.
- Insure that curved components of the graphic are actual curve segments as opposed to curves approximated by many tiny line segments. Graphics with many small components stall the cutter.
- Make sure that the graphic is closed. In other words check that the lines making up the graphic actually intersect at all apparent intersection points. Otherwise SignCad will not be able to recognize the boundaries for filling in the shape. Using the SNAP function in Microstation is a good way to ensure continuity.

In rare cases, you may need to create a special graphic from another type of image file (for example, a bitmap or jpeg photograph). Adobe Streamline has been found to be a useful tool for creating dxf files from this type of file. Any time you create a graphic that may have future application, submit it to the HQ Traffic Engineering Section for inclusion into the cell library or sign library. Templates for a large variety of roundabout symbols are provided in a Microstation cell library accessible from the sign library.

VIII. Shields:

The name “COLORADO” should be included on the shield for Interstate route markers, as shown in the example on the left, however when the shield is used on a guide sign only the route number should appear (as in the example on the right).



IX. Multi-panels:

When designing multiple overhead sign panels that will be adjacent to each other, always make sure they are of equal height even if some additional height beyond what is required for the signs message must be added to one of the panels. In addition, align like objects vertically on each sign whenever possible. For example, similar arrows, route markers and text should line up (See **Arrowhead** section below).

If an Exit Panel is not more than two feet narrower than main panel to which it will be attached, extend its width to match the full width of the main panel.

X. Arrowheads:

In the Appendix of the SHS, two (2) sets of arrows are illustrated for use in highway signs. With few exceptions, including guide signs, the “standard arrows” is for all types of signs. The “Up” and “Down” arrows are to be used for guide signs and recommended applications, as stated in Section 2D.08 of the 2009 MUTCD.

A. Standard Arrowheads:

These arrowheads conform to the dimensions specified on page 6-2 of the SHS. They are used primarily on approach road signs on lower speed roadways and should never be used on overhead signs or any Interstate guide signs. Below is a reproduction of the “Standard Arrow” detail.

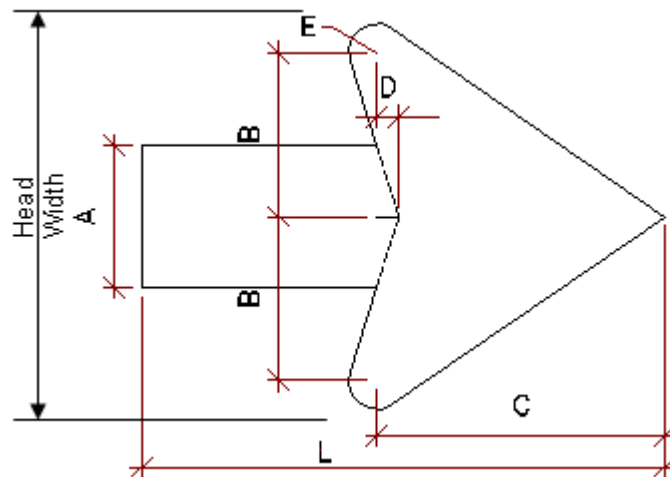

The sizing chart in the SHS book lists 27 arrow sizes. SignCAD has most of those sizes programmed in for selection. However, most of the standard sizes do not result in nice even total arrowhead widths. Therefore they will be hard to exactly match up with sign font sizes when putting horizontal arrows on signs. The sizing chart on the next page shows arrowhead parameter values that can be entered into SignCAD using “Custom” for the size, to obtain arrows of widths that will match common letter sizes. These are the only sizes that the CDOT Sign Shop currently provides.

Specifications for Common “Standard Arrow” Sizes

Head Width	Shaft Width (A)	Head Length (C)	Draft (D)	Radius (E)	Standard Lengths
4”	1.5”	3.063”	.25”	.313”	6” and 12”
6”	2.25”	4.5”	.375”	.438”	9” and 18”
8”	3”	6.125”	.438”	.563”	12” and 24”
10”	3.75”	7.625”	.563”	.75”	16” and 32”

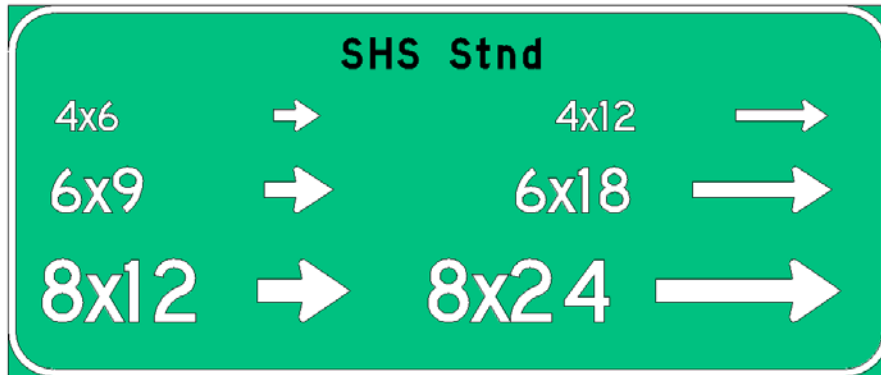

For most arrows, the arrow size should be selected so the head width equals the height of the largest letter on the sign. In cases where there is only one arrow on the sign and that arrow is vertical or at an angle, a larger arrowhead size can be used.

In addition to the arrowhead size, the designer will need to specify a length for these arrows. SignCAD has three default lengths for each of the programmed arrow sizes. All of the lengths shown in the above table are included in the SignCAD defaults with the exception of the 125” length for the 4” head width, and the 32” length for the 10” head width. Therefore, to use a different length shaft, you will have to use the custom arrow size option. Use the table above to find the values for the parameters that SignCAD needs. For examples of signs using standard arrows, please go to the CDOT Sign Library web page.

B. Up Arrows:

In addition to the “Standard Arrow”, SHS also specifies the design for an “Up Arrow” and a “Down Arrow” (SHS pg. 6-3). The “Up Arrow” with a 60° angle is used primarily on Exit Signs, Directional Signs and Gore Signs. Visually the “Up Arrow” design differs from the “Standard Arrow” design in that:

- The Up Arrow has a tapered shaft vs. a straight shaft on the Standard Arrow
- The Up Arrow has a round tip vs. a pointed tip on the Standard Arrow

There are three standard arrowhead sizes for this type of arrow, corresponding to the font size of the text to which the arrow pertains (8”, 10”-13.3” and 16”), each with two shaft length options. The designer should select from these standard arrows, using the largest font size on the sign as the determining factor. The diagram and table below, taken from page 6-3 of the SHS, summarize the geometries of the Up Arrow. **For most applications, use either the 18.25” arrow with the shorter (20”) shaft length, or a 22.25” arrow with the longer (35”) shaft length.**

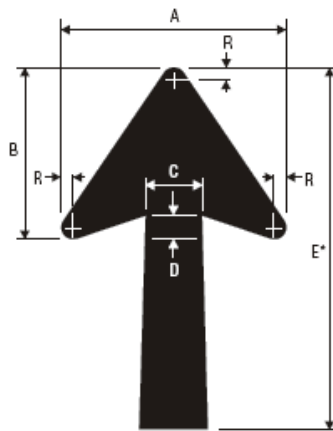

UP ARROW

Dimensions of Arrow When Used With Various Letter Cap Heights.

Letter Size	A	B	C	D	E*	R
8	15.125	11.563	3.75	1.313	17-25	.813
10-13.3	18.25	14	4.5	1.5	20-30	.75
16	22.25	17	5.375	1.75	25-35	1

*Taper of .5" per ft. should be held constant for longer or shorter shaft lengths.

For examples of signs using up arrows, please go to the CDOT Sign Library web page.

C. Down Arrows:

The “Down Arrow” is used only for lane designation. **This arrow will nearly always be of the standard size (22” height)** shown in the SHS and preprogrammed into SignCAD. In special cases, such as on off-ramps or on lower speed facilities, a smaller arrow might be needed. In this case, a 16.5” height is allowed. The diagram below, taken from page 6-3 of the SHS, shows the geometry of the standard Down Arrow. The table to its right shows the dimensions for the special small version of the arrow.

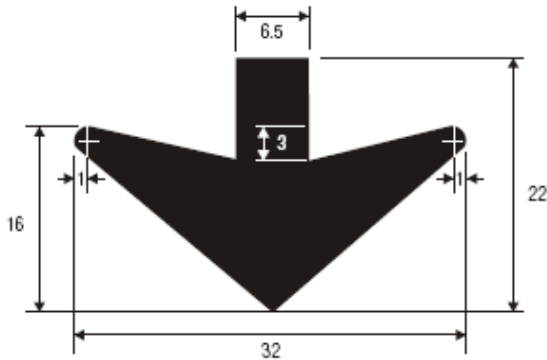

Smaller Arrow Size Dimensions

Head Width:	24
Head Length:	12
Radius:	0.75
Draft:	2.0
Shaft:	5.0
Length:	16.5

Note: Down Arrows should always be positioned so they are directly over the center of the lane. Therefore their spacing should equal the lane width, which would typically be 12’ (144”), but may be less on off-ramps or lower speed facilities.

Historical Note: Colorado formerly listed the two “Down Arrow” sizes in the Colorado Supplement to SHS, using the terminology “Type C” arrows, along with size specific designations, e.g. AR-C1 and AR-C2. The more standard terminology and sizing described above has been adopted in its place.

XIV. Pull Through Signs:

Show dimensions for lane centering on overhead panels as shown below. The text and arrows should be centered vertically within the yellow area. The words should be centered between the arrow and the edge of the panel for the single arrow design.

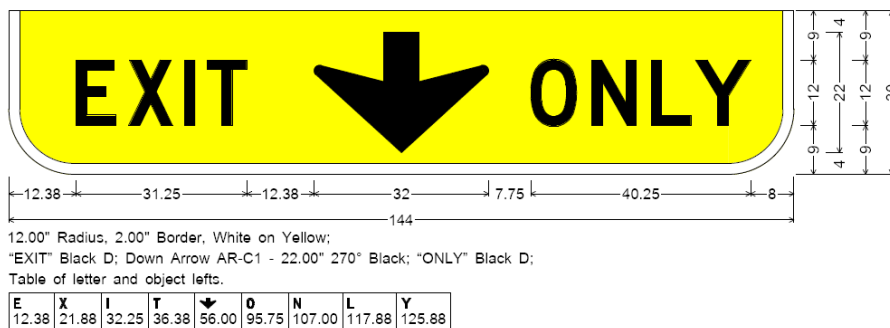

For the double arrow design the words should be centered between the two arrows.

ARROWS MUST BE 144" ON CENTER



Submittal Protocols

All sign layouts should be scaled 1:50 typical.

I. Title Block:

Sign layouts should always include a title block that contains, as a minimum, all of the following informational items:

- Project Number
- Project Code
- Sign Number
- Date
- Scale (1:50)
- Sign Type (e.g. Overhead, Class II Ground Sign, etc.)
- Sign Color
- Post Type
- Backing Zees (Y/N) 2.33# Zee Size Full Width (Y/N)
- Designer name
- Comments

II. Dimensions:

When selecting the dimension options (SignCad), always select "Include Last Dimensions". This shows the spacing from the end of the last object to the edge of the sign panel. This not only makes the layout appear more complete, but it provides a means of checking that the layout is correct.

All sign layouts should include a "Table of Lefts" that shows the position of every object on the sign. This information allows the sign fabricator to quickly place the objects along a fixed scale without having to measure from one object to the next. Including the table in this format is a SignCad option.

Post Selection

I. Panel Sizes:

For panel width in the size range between 1 and 11 feet, one or two tubular steel posts should be used, as specified in Standard Plan S-614-8, for wind loading up to 90 mph. For higher wind areas, the designer should verify the sufficiency of the recommended post selection, and use a more robust design, if necessary.

Some additional sizes can be accommodated with three tubular steel posts. **Table 1** summarizes these options. The darker shaded squares are those that would be most likely to be used. The yellow area represents sizes that need to be handled with W-Shape Beam steel posts. The unshaded area corresponds to sizes that can be installed using less than three posts.

Table 1: Three Post Tubular Steel

		Width (Ft.)												
		9	10	11	12	13	14	15	16	17	18			
Height (Ft.)	1													Use either Three Post Tubular Steel or W-Shape Beam Use W-Shape Beams Only for Sign Posts
	2													
	3													
	4													
	5													
	6													
	7													

For panel sizes that exceed these dimensions, W-shape steel posts should be used, as shown in **Table 2**.

Table 2: W-Shape Beams

		Width (Ft.)																	
		8	9	10	11	12	13	14	15	16	17	18	19	20	21	22	23	24	
Height (Ft.)	4	Use 3 Post Tubular Steel or											Use W-Shape Beams Only						
	5	W-Shape Beam Posts											Use W-Shape Beams Only						
	6	Posts for these											Beams Only						
	7	panel sizes											for Sign Posts						
8 +	Use W-Shape Beams Only for Sign Posts																		

II. Post Spacing:

Post spacing is determined according to the Post Spacing Table in Standard Plan S-614-4, Sheet 3 of 3.

The selection of the specific size of W-shape posts must be determined by the engineer based on wind load. The formula for calculating the moment (in ft-lbs) at the sign base = M.

$$M = \frac{A \times D \times P}{1000 \times N}$$

where: A = Area of the sign

D = Distance from the centroid of the sign panel to the bottom of the longest post

P = *Wind Pressure (Use 22 psf for 80 MPH or 35 psf for 100 MPH)

N = Number of posts

*The Wind pressure is taken from an AASHTO table based on wind speed.

Once the wind load is calculated, use the table in Standard S-614-6 to select the post size.

Alternately the designer may use an Excel program called “FOOTINGS II (Variable Wind Speed).XLS” to calculate the post size. This file can be downloaded from \\Public\trafcom\Traffic_Engineering_Resource_Library\Sign_Design_Guide\FOOTINGS II (Variable_Wind_Speed).XLS

III. Backing Zee Guidelines:

The sign backing reinforcement to use is the 2.33# zee bar. A backing zee spacing table is shown in Standard Plan S-614-4, Sheet 3 of 3 and is used for Class III signs on all post types and uses only the 2.33# zee bar size.

NOTE: All previous methodologies that directed different backing zee usage (including the use of larger size zees) have been superseded by the method described in this Post Selection chapter.

Acknowledgements

KC Matthews (CDOT Safety & Traffic Engineering)
Jim Williams (CDOT Safety & Traffic Engineering, *Retired*)
Ken Nakao (CDOT Safety & Traffic Engineering)
San Lee (CDOT Safety & Traffic Engineering)
Ben Kiene (CDOT Region 6)
Paul Neiman (CDOT Region 6)
Gary Shackleton (CDOT Sign Shop)