

Open-File Report 96-4  
Field Trip No. 20

**History, Geology, Hydrogeology, Summitville Mine  
and Downstream Effects, and Other Nearby Mines  
of the San Luis Valley, Colorado**

**CGS LIBRARY**

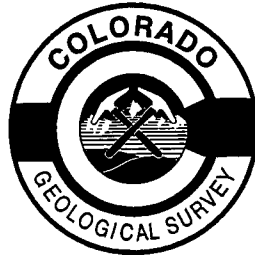

Colorado Geological Survey  
Department of Natural Resources  
Denver, Colorado  
1996

Open-File Report 96-4  
Field Trip No. 20

**History, Geology, Hydrogeology, Summitville Mine  
and Downstream Effects, and Other Nearby Mines  
of the San Luis Valley, Colorado**

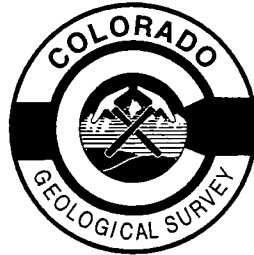

Colorado Geological Survey  
Department of Natural Resources  
Denver, Colorado  
1996

# Table of Contents

## Field Trip 20

### SECTION I: A BIT OF HISTORY

- *Changing Hydrologic Regimes and Prehistoric Landscape Use in the Northern San Luis Valley, Colorado*

Margaret A. Jodry and Dennis J. Stanford

### SECTION II: GEOLOGY AND HYDROGEOLOGY

- *General Geology of the Northern San Luis Valley, Colorado*

James P. McCalpin

- *Tertiary Stratigraphy and Tectonic Development of the Alamosa Basin (Northern San Luis Basin), Rio Grande Rift, South-Central Colorado*

Brian S. Brister and Robbie R. Gries

- *Hydrogeology of the San Luis Valley, Colorado, An Overview - and A Look at the Future*

Philip A. Emery

- *Water Level Changes in the Unconfined Aquifer of the San Luis Valley, 1980-1995*

Isobel R. McGowan and Dan Plazak

- *Evidence Supporting Enhanced Upward Ground Water Flow in the San Luis Valley, Colorado*

Charles E. Stanzione

## Table of Contents

- ▶ *Geomorphic Evolution and History of Pollution in the Vicinity of the Summitville District, San Juan Mountains, Colorado*  
Thomas A. Steven
  
- ▶ *Hydrothermal Alteration Assemblages As A Control on Water Chemistry, Upper Alamosa River, Colorado*  
Dana J. Bove, Anna B. Wilson and Thomas H. Barry
  
- ▶ *Naturally Occurring, Acidic, Metal-rich Springs in the Upper Alamosa River Basin, Colorado*  
Robert M. Kirkham and Jonathan Lovekin
  
- ▶ *Attenuation of Metal Concentrations in Terrace Reservoir, Conejos County, Colorado, May 1994 Through May 1995*  
Robert W. Stogner, Sr.
  
- ▶ *Evaluation of Metal Transport Into and Out of Terrace Reservoir, Conejos County, Colorado, April 1994 through March 1995*  
Sheryl A. Ferguson
  
- ▶ *The Alamosa River Irrigation System, Western Central San Luis Valley, Colorado*  
Susan Ford and David Skidmore
  
- ▶ *Geochemical Dispersion In Soils On The Alamosa River Floodplain, San Luis Valley, Colorado*  
Ronald R. Tidball

# Table of Contents

- ▶ *San Luis Valley Project, Closed Basin Division*  
Bureau Of Reclamation (Rich Demlo, et.al.)
  
- ▶ *Geology of the Northeastern San Luis Basin, Saguache County, Colorado*  
Thomas A. Watkins
  
- ▶ *The Analysis of Rabbitbrush (genus Chrysothamnus) and the Detection of a Possible Hidden Geothermal Field in the Northern San Luis Valley*  
James A. Erdman
  
- ▶ *The Role of Streams in the Development of the Great Sand Dunes and Their Connection With the Hydrologic Cycle*  
Andrew D. Valdez
  
- ▶ *Alamosa River Watershed Project*  
Jeff M. Stern
  
- SECTION III: SUMMITVILLE MINE AND DOWNSTREAM EFFECTS**
  
- ▶ *Geological Characteristics of the Summitville Mine and Their Environmental Implications*  
John E. Gray and Geoffrey S. Plumlee
  
- ▶ *The Mining History and Environmental Clean-Up at the Summitville Mine*  
Victor L. Ketellapper and James A. Pendleton, Harry H. Posey, and Mike B. Long

## Table of Contents

- ▶ *Mineralogical Alterations of Soils Irrigated With Acidic Mine Water in the Alamosa River Basin*  
Stephanie J. Connolly and Steve W. Blecker, Grant E. Cardon, and Eugene Kelly
  
- ▶ *Stream Contamination From the Summitville Mine and Its Impact on Alfalfa Production in Part of the San Luis Valley*  
James A. Erdman and Kathleen S. Smith
  
- ▶ *The Biogeochemistry of Wetland Ecosystems And Tree Rings in the San Luis Valley, Colorado: The Effect of Natural And Human-induced Metal-rich, Acid Drainage*  
L.P. Gough, L.S. Balistrieri, F.E. Lichte, T.M. Yanosky, R.C. Severson, and Andrew Archuleta

### **SECTION IV: OTHER NEARBY MINES**

- ▶ *A Proactive Removal Program at the Bonanza Mining District, Bonanza, Colorado*  
Margaret W. Staub and Bence V. Close
  
- ▶ *The San Luis Mine*  
Sally Hayes Kaiser
  
- ▶ *Geology of the San Luis Gold Deposit, Costilla County, Colorado: An Example of Low-angle Normal Fault and Rift-related Mineralization in the Sangre De Cristo Range of Colorado*  
Robert G. Benson and David M. Jones
  
- ▶ *Effect of Mining on Water Quality in the Red River, Taos County, New Mexico*  
Daniel J. Plazak

# CHANGING HYDROLOGIC REGIMES AND PREHISTORIC LANDSCAPE USE IN THE NORTHERN SAN LUIS VALLEY, COLORADO

By

Margaret A. Jodry and Dennis J. Stanford  
Smithsonian Institution  
Paleoindian/Paleoecology Program  
National Museum of Natural History 304  
Washington, DC 20560

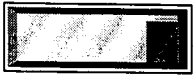

## ABSTRACT

The rise of specialized, Paleoindian bison hunters in the Rocky Mountains accompanied the paleoecological transitions characterizing the terminal Pleistocene. In the closed-basin of the San Luis Valley, these climatic changes impacted the distribution and abundance of wetland resources. Water tables rose between ~10,900 and 10,500 yr B.P., creating grassland habitats, locally abundant playa lakes, and providing human populations with abundant prey and ready ambush locations during bison hunting. Extensive excavation (1300 m<sup>2</sup>) and analysis of Stewart's Cattle Guard site provides an in-depth view of Folsom bison butchery, hide processing, and weaponry maintenance in a late Pleistocene, fall hunting camp. A trend toward warmer and drier conditions followed this mesic interval, punctuated by periods of increased moisture. Human populations adapted by varying their subsistence and settlement strategies. Greater reliance on plants such as Indian rice grass and hunting of smaller game distinguish Holocene adaptations. By 9500 yr B.P. pinyon trees were established in the area and their nuts became a dietary staple. A myriad of pinyon harvesting sites dot the foothills. On the valley floor, the archaeological remains of fishing camps document the use of former lakes and marshes. This paper discusses the archaeology of the San Luis Valley in light of paleoclimatic information provided by hydrological and palynological studies.

## INTRODUCTION

Prehistoric human adaptations developed in relation to the changing ecosystems of which they were a part. The Paleoindian/Paleoecology Program at the Smithsonian Institution investigates the interplay between the earliest inhabitants of the New World and the dynamic reorganization of climatic, hydrologic and biotic regimes during the terminal Pleistocene. Of particular interest to our work in the San Luis Valley are the possible effects of the late Pleistocene Younger Dryas cold episode (~11,000 to 10,000 yr B.P.) on paleoenvironments, biotic carrying capacity, and hunting practices during the cultural

transition from Clovis to Folsom ~10,900 yr B.P. (Haynes, 1993).

People are thought to have first entered the San Luis Valley ~11,200 yr B.P. Their archaeological remains are identified by diagnostic, fluted weapon tips, known as Clovis points, found in association with the butchered remains of extinct proboscidiens, bison, turtles, and other fauna at a number of sites in North America (e.g. Frison and Todd, 1986; Haynes, 1987; Graham and Kay, 1988; Ferring, 1989). The disappearance of Clovis assemblages approximately three hundred years later may be a cultural reflection of the marked environmental changes and megafaunal extinctions at the end of the Pleistocene (Haynes, 1991, 1992).

Toward the end of Clovis, the Rocky Mountains and adjacent Plains became the domain of other hunter-gatherers (Frison, 1991, 1996), including members of the Folsom Culture, dated ~10,900 to 10,200 yr B.P. (Haynes et al., 1992). The predominant prey of Folsom groups was *Bison antiquus*, the largest herbivore to survive the late Pleistocene extinctions in North America. Communal bison hunting, as a focused rather than an opportunistic endeavor, apparently arose in the context of climatic conditions which favored the expansion of bison herds and habitat ~10,900 yr B.P.

The Smithsonian has investigated four Folsom sites in the San Luis Valley: Reddin, 5SH77; Linger, 5AL91; Zapata, 5AL90; and Stewart's Cattle Guard, 5AL101 (Figure 1). In conjunction with this research, palynological analyses of sediment cores from Como Lake in the Sangre de Cristo Mountains and Head and San Luis Lakes on the valley floor were initiated at the University of Arizona. These studies allow interpretation of post-glacial environmental and climate change in the Northern San Luis Valley.

## GEOLOGIC AND HYDROLOGIC SETTING

The San Luis Valley is the largest of a series of high-altitude, intermontane basins located in the Southern Rocky Mountains. Geologically, this basin is a structural

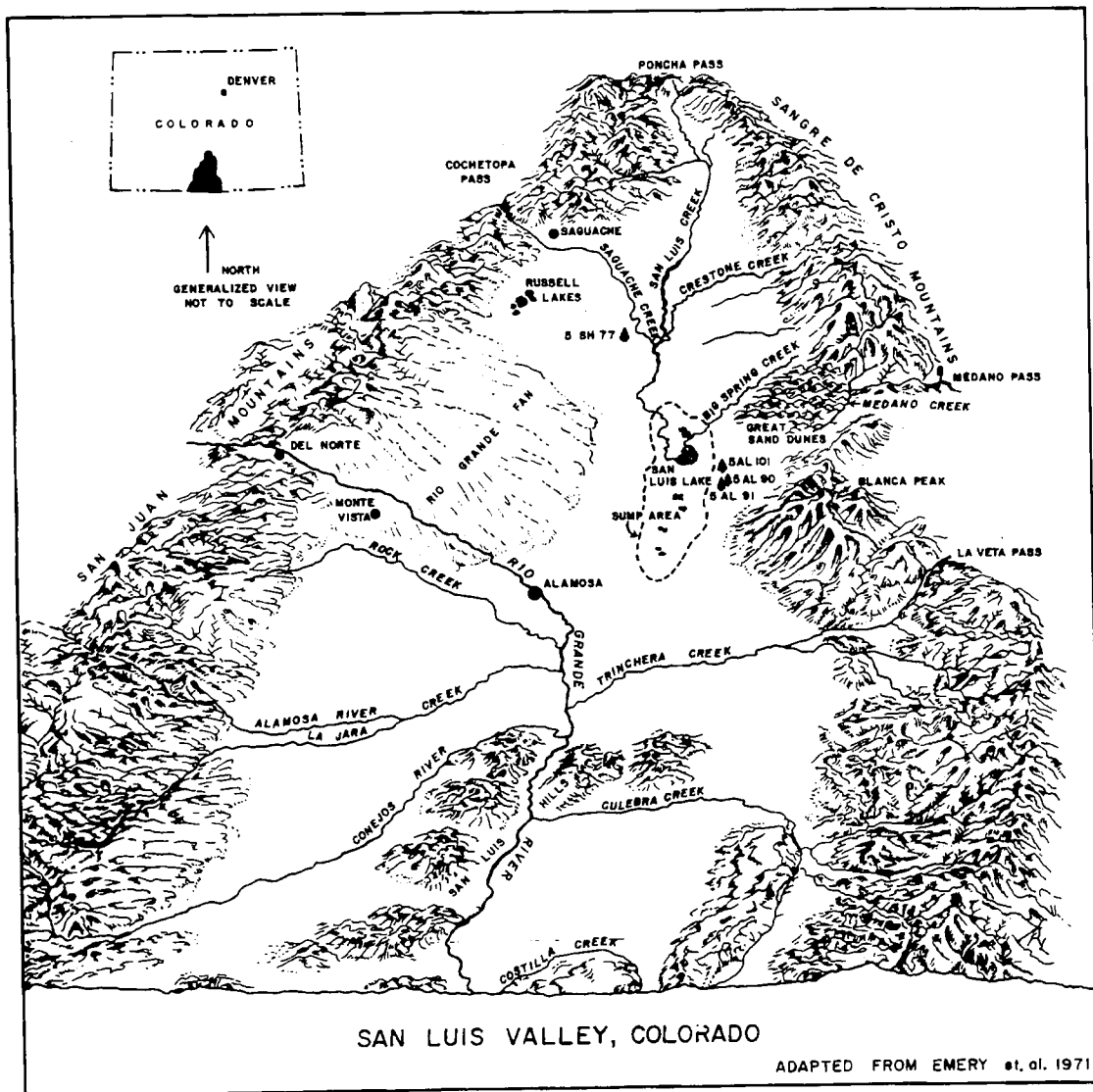

Figure 1 Map of the San Luis Valley showing the location of the Reddin (5 SH 77), Linger (5AL 91), Zapata (5 AL 90), and Stewart's Cattle Guard (5 AL 101) Sites.

depression (compound graben) that was down faulted along the base of the Sangre de Cristo Mountains and hinged at the base of the San Juan Mountains during the Cenozoic faulting of the Rio Grande Rift Zone (Chapin, 1971; Bachman and Mehnert, 1978). This created an asymmetrical basin with a topographic depression along the east side where aquifers are more extensive (Figure 2). The northern portion of the valley, from Poncha Pass to a few km north of the Rio Grande, is a closed hydrologic basin. Surface water drains toward the low-lying area currently occupied by San Luis and Head Lakes, where the piezometric surface is relatively shallow.

The shallow nature of this water table greatly influences the character of the San Luis Valley. Minor fluctuations in its level can result in dynamic shifts between wetland and xeric habitats. Our studies indicate that increases in effective moisture at various times in the past led to the enlargement of San Luis Lake, and the creation of interdunal ponds and marshes.

## PALYNOLOGICAL EVIDENCE FOR ENVIRONMENTAL CHANGE

The closed-basin lakes of the western United States contain proxy records of the oscillations in temperature and precipitation which accompanied climatic change during the last deglaciation (Benson and Thompson, 1987; Forester, 1987; Smith and Street-Perrott 1983). Analysis of pollen and plant macrofossils from the sediments of Como, Head, and San Luis Lakes provide the first records of postglacial vegetation and climate history for the San Luis Valley (Shafer, 1989; Davis and Shafer, 1991; De Lanois, 1993), and temporally extend the detailed paleoenvironmental databases established for the Middle Pleistocene of this area by Rogers et al. (1985, 1992).

### Como Lake

Como Lake is located on the east side of the San Luis Valley, south of the Great Sand Dunes. It is the lowest (3669 m) in a series of lakes occupying a glacial basin in the Holbrook Creek Drainage on Blanca Peak, the highest point (4373 m) in the Sangre de Cristo Mountains (Shafer, 1989). The lake currently lies ~110 m below upper treeline and has a discontinuous forest cover dominated by Engelmann spruce (*Picea engelmannii*), subalpine fir (*Abies lasiocarpa*) and bristlecone pine (*Pinus aristata*).

A 300 cm composite core (collected through water using a 5 cm piston corer) consisted of gyttja becoming siltier with depth and terminating in basal deposits of glacial rock flour. Five radiocarbon dates from spruce (*Picea*) macrofossils and gyttja provide chronologic control (Shafer, 1989). Late Quaternary temperature change can be inferred from the fluctuating position of upper treeline as reflected in the lake's pollen and plant macrofossil records. In addition, signatures of valley-floor vegetation are

represented due to upslope transport of pollen (Shafer, 1989; Jodry et al. 1989).

The late-glacial pollen assemblage is dominated by wide-spread sagebrush (*Artemisia tridentata*) and grasses (*Gramineae*) on the basin-floor. By ~10,500 yr B.P. a sharp increase in the percentages of spruce and pine pollen (including *Pinus aristata*) suggests that upper treeline had reached the lake following full-glacial lowering. Peaks in pine and spruce macrofossils suggest a maximum upslope advance of upper treeline from 9879 to 9571 yr B.P. (at least 175 to 203 m higher than present). This overlaps with the period of maximum July insolation values during the late Quaternary (~9600 to 9000 yr B.P.) predicted by the atmospheric general circulation models (Kutzbach, 1987). Continuous forest cover around Como Lake may have persisted until ~5500 yr B.P. when subalpine fir and bristlecone pine macrofossils last occurred. Reduced charcoal in sediments after ~4000 yr B.P. further indicates a lowering of timberline below Como. Just prior to ~2000 yr B.P. Engelmann spruce macrofossils reappear, suggesting that timberline may have reached the elevation of the lake once again (Shafer, 1989).

Signatures of valley-floor pollen suggest the following trends. The high pollen percentages for sagebrush and grasses in the late Pleistocene vegetation decline markedly after ~10,000 yr B.P. After ~9500 yr B.P., the percentages of greasewood pollen (*Sarcobatus vermiculatus*) steadily rise, suggesting that soil alkalinity increased gradually through the Holocene. Maximum percentages occurred ~6500 to 3500 yr B.P. (Shafer, 1989). Higher percentages of conifer pollen (*Pseudotsuga*, *Pinus edulis*) from ~7000 to 5500 yr B.P. may indicate that lower ecotones migrated upward in response to drought stress (Shafer, 1989). The period of least effective moisture inferred from the Como core appears to be ~6500 yr B.P.

The Como Lake records seem to indicate shifts in the relative contribution of air masses as sources of precipitation in the San Luis Valley during the late Quaternary (Shafer, 1989). Prior to ~8000 yr B.P., high *Artemisia*/Cheno-Am ratios and lower ecotones for *Pseudotsuga*, and for summer precipitation dependent conifers such as ponderosa and pinyon pine, suggests the probability of enhanced monsoonal circulation. The appearance of pinyon pine pollen at Como Lake by 9500 yr B.P. may indicate its expansion during a warmer period of greater summer precipitation.

### Head and San Luis Lakes

Head (2310 m) and San Luis Lakes (2300 m) are located adjacent to one another on the east side of the San Luis Valley, a few km west of the Great Sand Dunes. Sediment cores were collected from both localities through winter ice using a vibracorer. Preliminary data from Head Lake are reported in Shafer, 1989; Jodry et al., 1989; and Davis and Shafer, 1991. De Lanois (1993) reports sediment

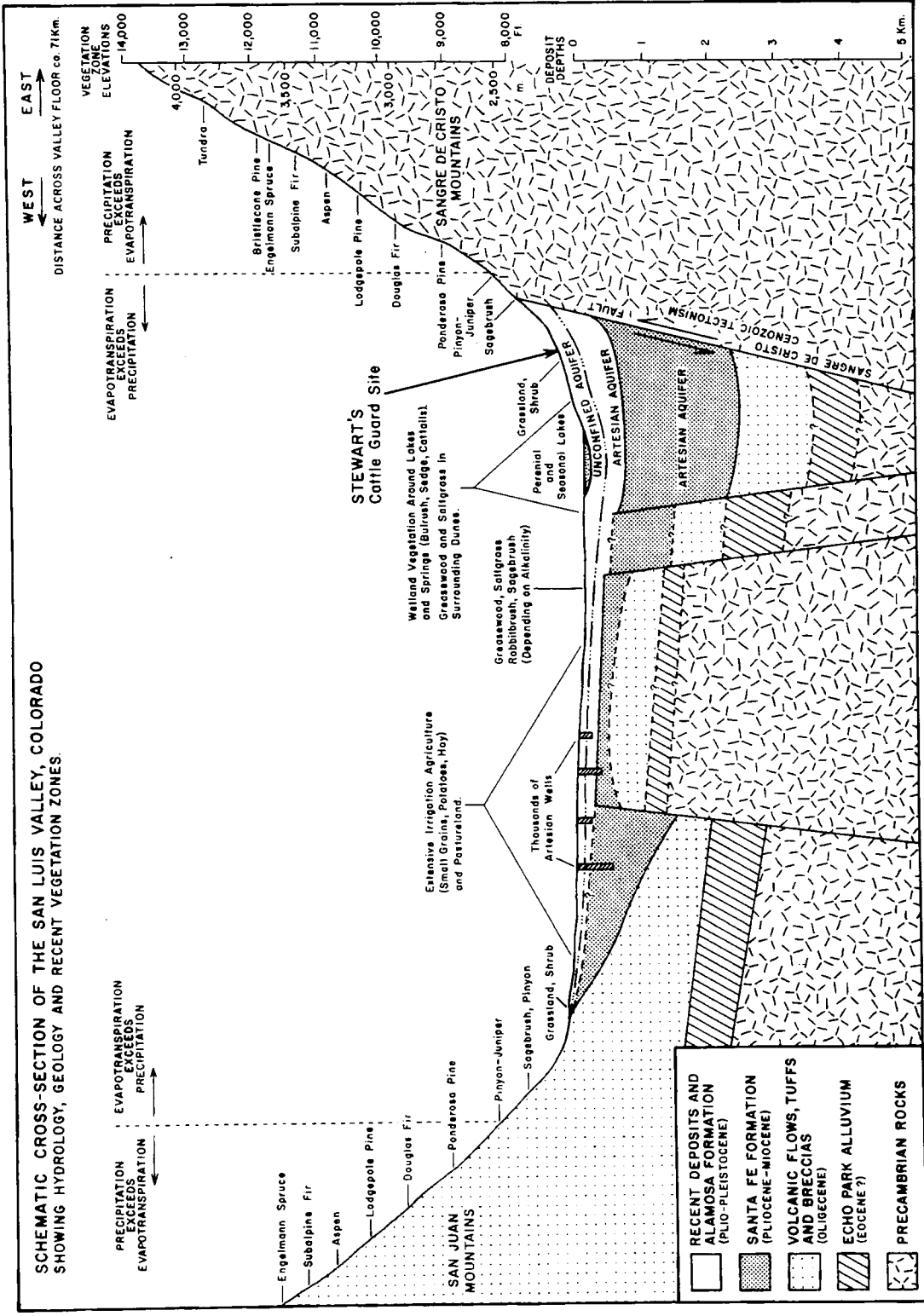

Data Sources: Dixon 1971, Emery et al 1971, McCalph 1963, Powell 1956, Tweto 1979.

Figure 2 Schematic cross-section of the San-Luis Valley.

and pollen analyses of San Luis Lake. Current vegetation around the lakes is dominated by greasewood (*Sarcobatus vermiculatus*) shadscale (*Atriplex* sp.) and rabbitbrush (*Chrysothamnus* sp.).

### Head Lake

The 260 cm core from Head Lake consists primarily of calcareous sand and sandy clay or silt. Four radiocarbon dates from bulk sediment samples provide chronologic control for the upper 130 cm, that portion of the core which post-dates 11,060 +/- 160 yr B.P. (uncalibrated) (Shafer, 1989; Davis and Shafer, 1991). The carbon content of the lakes' basal sediments is very low, so the standard deviations of the conventional dates are large (Davis and Shafer, 1991). The concentration of pollen decreases substantially in this core between depths of 130 and 190 cm, due to rapidly accumulating sand, and perhaps due also to low local pollen production.

Preliminary analysis indicates that oak (*Quercus*) pollen was most abundant at depths of 100-80 cm, prior to ~11,000 yr B.P. Sagebrush pollen was relatively abundant during this period and greasewood percentages were low (Jodry et al., 1987). The peak occurrence of oak in the Head Lake core is undated, but a similar rise in *Quercus* pollen at Bechan Cave in southeast Utah begins ~13,000 yr B.P. (Shafer, 1989).

The record of aquatic plants at Head Lake suggests that water levels were higher during the latest Pleistocene. Peak percentages of *Pediastrum* (algae) at a core depth of 50 cm (~11,000 to 10,700 yr B.P.) probably signifies that water levels and surface water area were at a maximum. The emergent aquatic plants appear to have been less abundant at maximum water levels. Today, Head Lake is closely bounded by sand dunes. If this setting occurred in the past, the dunes may have arrested development of a shallow water littoral zone at higher lake levels that would have supported emergent aquatic plants (Jodry et al., 1989).

By ~5200 yr B.P. lake levels had dropped precipitously; *pediastrum* disappeared and greasewood pollen reached maximum percentages, probably reflecting the expansion of this halophyte onto the saline margins of the receding lake (Jodry et al., 1989).

The lake levels on the San Luis Valley floor are today largely controlled by the shallow, unconfined aquifer, recharge to which is mostly from direct surface infiltration rather than runoff from the adjoining mountain ranges (Emery et al. 1971). If this relationship was true in the past, it suggests that higher water levels in Head Lake in the late Pleistocene/early Holocene were a result of greater precipitation (Jodry et al., 1989). The expansion of Gambel's oak and Colorado pinyon pine during this time period suggests that southwest monsoon precipitation may have been the source, as predicted by general atmospheric circulation models (Kutzbach, 1987; Kutzbach et al. 1993).

### San Luis Lake

The San Luis Lake core records climatic change during the late Holocene, from ~1200 yr B.P. (A.D. 750) to the present. A 154 cm long core, consisting of coarse to silty sand, was removed from the southwestern portion of the lake (De Lanois, 1993). Four bulk sediment dates (uncalibrated) ranging from 920 +/- 60 yr B.P. to 17 +/- 56 yr B.P. provide chronologic control for the upper 90 cm of the core.

The deepest levels producing pollen (zone A) are tree-ring calibrated by De Lanois (1993) to date between 1014 and 1230 yr B.P. (~A.D. 950-750) (Stuiver and Becker, 1986). Temperatures warmer than modern climate are suggested by the increases in pine and greasewood at the expense of sagebrush. Non-arboreal pollen dominates and algae percentages are low. The warmest/driest interval represented in the core occurs A.D. 1090. This is temporally consistent with a regional climatic warming event, the Medieval Warm Period, dated A.D. 1149 (De Lanois, 1993).

Zone B, 520 to 988 cal B.P. (~A.D. 430-960), shows a cool/wet period characterized by abundant non-arboreal pollen and peaks in charcoal and algae (*Pediastrum* and *Botryococcus*), followed by somewhat warmer and drier conditions.

Zone C, from 174-520 cal B.P. (AD 1776-1430), indicates conditions which were cooler and wetter than present with arboreal pollen dominance (including *Pinus*, *Abies*, *Picea*, *Juniperus*, and *Quercus*) and low algae percentages. These data correlate with the Little Ice Age climatic event dated elsewhere between A.D. 1500-1800.

Zone D, from the present to 100 cal B.P. (A.D. 1850-1978), documents the appearance of Russian Thistle (*salsola*, 1%) and increases in dung fungus (*sporomiella*, 6%) associated with the introduction of cattle and sheep in the historic period. High percentages of non-arboreal pollen (i.e. *Chenopodiaceae-Amaranthus* and *Sarcobatus*) and algae suggest a return to warmer and drier conditions, with a cooling trend toward the present (De Lanois, 1993).

### Sporomiella and Biomass

Palynological studies (Davis, 1987; Davis and Shafer, 1991, 1992) suggest that increases in the abundance of spores from the dung fungus, *sporomiella*, are good proxy indicators of expanded herbivore biomass. Peaks in *sporomiella* are associated with increased concentration of historically-introduced livestock. Similar peaks are also noted during the late Pleistocene (Davis, 1987; Davis and Shafer, 1991).

*Sporomiella* is common on the dung of domestic herbivores, of living megaherbivores, of some smaller herbivores, and is documented in the Pleistocene dung from Bechan Cave in southeast Utah (Davis et al., 1984). Values greater than 3% are characteristically associated with maximum grazing intensity in historic sediment samples

and this percentage is used as a comparison with Pleistocene occurrences (Davis and Shafer, 1991).

All three of the lakes cored in the San Luis Valley contain *sporomiella* spores. However, the spores at San Luis Lake are limited to the historic period when they occur above 2% for the first time in zone D (De Lanois, 1993). At Como Lake, "Sporomiella percentages range from 0.2 - 0.7% in the historic period, from 0.2 - 1% from 4390 +/- 80 to 7720 +/- 100, and from 2.0 - 4% in sediments from 10,260 +/- 330 and 11,730 +/- 290 yr B.P. These Pleistocene percentages are among the highest recorded for sediments of this age, and the transition to lower Holocene values is abrupt" (Davis and Shafer, 1991:5).

Similar values are documented at Head Lake: 0.7 - 2% in the historic period, <0.3% in the Holocene, and up to 4.8% in samples between 10,920 +/- 200 and 11,060 +/- 160 yr B.P. (Davis and Shafer, 1991). The Head lake sediments produced the highest percentages of *sporomiella* yet recorded by Davis and Shafer for Pleistocene lakes.

*Sporomiella* percentages decline after ~10,800 yr B.P. at Como Lake and subsequent to 11,010 yr B.P. at Head Lake. "At both sites, the *Sporomiella* decline is immediately followed by a major climatic oscillation from cold-wet (10,500 at Como; 10,750 at Head) to hot/dry (10,190 at Como; 10,490 at Head)" (Davis and Shafer, 1991:6).

This evidence suggests that the carrying capacity for large herbivores was particularly high during the mesic interval coincident with the Folsom occupation of the San Luis Valley. The greater abundance of Folsom sites relative to sites attributed to either Clovis or Late Paleoindian periods appears to reflect the especially attractive nature of the basin environment at this time.

## ARCHAEOLOGICAL EVIDENCE FOR PREHISTORIC USE OF PLUVIAL LAKES

### Late Pleistocene

Paleoindian settlement patterns strongly support the former presence of playa lakes in the San Luis Valley during the Folsom time period. Interdunal pond deposits are present at the Linger and Zapata sites in the partially-stabilized sand sheet lying to the southwest of Great Sand Dunes National Monument. Playas are also associated with the Folsom occupations at the Reddin site situated in the currently dry, alkaline flats near Saguache Creek.

Smithsonian excavations at the Linger site (5AL91) in 1977 uncovered a Folsom bison kill (Dawson and Stanford, 1975; see also Hurst, 1943). At least five animals were apparently ambushed while watering at a small pond (delineated by a buried limonitic sand). A hunting camp was established about thirty meters upslope where the remains of additional butchering and weaponry repair were uncovered. Limited testing at the nearby Zapata site (5AL90) in 1978 also revealed butchered bison in

association with Folsom tools near the edge of a pond (denoted by cemented lacustrine deposits).

The Reddin site (5SH77) consists of several piecemeal Folsom surface localities distributed between two playas on the south and Saguache Creek to the north and west. The broken tips of Folsom points were concentrated near the playa edges and suggest that hunting occurred there. The primary camping locality appears to have occupied a low ridge adjacent to Saguache Creek where a greater variety of Folsom tools were recovered (Stanford, 1990).

Ongoing excavations at Stewart's Cattle Guard site provide a detailed view of campsite activities associated with Folsom bison hunting in the San Luis Valley. At least forty-five bison were killed and processed here in a briefly occupied, fall site. Immediately next to the kill area, the hunting group established a campsite where domestic activities (i.e. eating, sleeping, weaponry maintenance) were undertaken around a series of closely-spaced hearths (Jodry, 1987; Jodry and Stanford, 1992). Primary butchery and the processing of hides took place in adjacent locations. Conjoined fragments from broken or refurbished tools interconnect the different activity areas and suggest their contemporaneity (Jodry, 1992). Tool stone from source areas as far away as the Texas Panhandle and the Chuska Mountains of northwest New Mexico indicate far-reaching patterns of travel and social interaction.

The paucity of Clovis and later Paleoindian artifacts at known Folsom-age playas in the valley suggest that these lacustrine features were not present and support palynological indications for less effective moisture immediately pre- and post-Folsom. Geohydrologic and paleolimnological data from Texas, New Mexico, and Arizona (summarized in Jodry et al., 1989; Haynes, 1991, 1993) support the regional nature of a late Pleistocene/early Holocene stratigraphic sequence characterized by a Clovis dry period, followed by a Folsom-age mesic interval, and then a drying and warming trend during late Paleoindian times (10,000 to 8000 yr B.P.).

Haynes (1993) notes that the dry period ~11,000 yr B.P. immediately followed by the emergence of pluvial lakes and elevated water tables correlates well with climatic fluctuations observed in the oxygen isotope records of Greenland ice cores and European lacustrine sediments (Peterson and Hammer, 1987). "Both show a marked decrease in  $\delta^{18}\text{O}$  during a cold, dry period that ended the Pleistocene in 10,750  $\pm$  150 B.P. The period of decreased  $\delta^{18}\text{O}$  is correlated with the Younger Dryas of Northern Europe" (Haynes 1993:233). The apparent peak in the San Luis Valley of Paleoindian populations during Folsom is coincident with the period of rapid warming which followed the Younger Dryas. The especially, well-watered dune field covered in nutritious grasses, at that time, apparently supported a significant bison and bison-hunter population.

## Holocene

While Folsom sites on the valley floor were often situated near relatively small ponds, a number of later (poorly dated) Holocene sites appear to be oriented toward a larger wetland system overlapping the Blanca Wildlife Refuge in the vicinity of Dry Lakes (Jodry et al., 1989). The distribution of archaeological sites in this area indicates the former presence of interconnected lakes and marshes at least 17 km long by 1.5 to 5 km wide (Jones, 1977).

Archaeological survey by Adams State College in conjunction with the creation of Blanca Wildlife Refuge documented the presence of 134 prehistoric sites (Dick, 1975). Four of these localities were tested by Colorado State University (Jones, 1977). Their excavation of site 5AL80, uncovered a 50 cm thick midden deposit containing large amounts of charcoal and fishbone. The midden contained three strata, the uppermost of which yielded a radiocarbon date of 1670 yr B.P.  $\pm$  55 (A.D. 280; UGA-1429) (Jones, 1977). Cultural material associated with the midden was not temporally diagnostic, but the fish remains were most informative.

Rio Grande Chub (*Gila nigriscens*) dominated the fish assemblage. Also present were two species of buffalofish (*Ictiobus sp.*). While Rio Grande chub may be caught using a hook and line; buffalofish were more likely recovered in traps or nets when the fish moved into shallow areas to spawn (Jones, 1977).

As buffalofish require water depths of ~3.65 to 4.5 meters to survive, these figures provide a basis for preliminary reconstructions of the former wetland habitat. When 3.65 meters is added to the common elevations (2288 m/7507 ft) of the old lake bottoms still visible near the site, a hypothetical lakeshore falls along the 7520 foot (2292 m) topographic contour (Jones, 1977). Strong support for this reconstruction is provided by the distribution of archaeological sites in the vicinity. Over ninety percent of the 134 sites lie adjacent to, or slightly higher than, the reconstructed shoreline at 7520 feet (Jones, 1977; Figure 3).

A topographic map, superimposed with the reconstructed wetlands, delineates irregularly-shaped ponds interspersed with low, marshy areas and peninsulas of relatively dry land (Jodry, 1987; Figure 4). In addition to fish, these wetlands offered human groups a wide array of plant and waterfowl resources.

The radiocarbon date of 1670 yr B.P. temporally places the site containing the buffalofish (5AL80) within the Little Ice Age climatic episode documented in zone C at Head Lake. The presence of middle to late Archaic artifacts (typologically dated between ~5000 and 1450 yr B.P.) in the area, suggests that there were additional periods of wetland availability.

## CONCLUSIONS

The archaeological record of the San Luis Valley suggests nearly continuous human occupation beginning during the Younger Dryas Climatic Episode ~11,200 yr B.P. Clovis weapon tips, made by the earliest inhabitants, are relatively scarce. They were reportedly associated with the remains of a mammoth at a disturbed archaeological locality near Great Sand Dunes (Stanford, 1990,) and as isolated finds in scattered locations across the valley. More effective moisture ~10,800 yr B.P. transformed the basin into a biomass-rich habitat well-suited to human groups, such as Folsom, with specialized, bison-hunting economies.

Warmer, drier conditions, and the apparent waning in strength of the southwest monsoon, ~10,000 yr B.P. initiated large-scale changes in hydrologic and biotic regimes. Human groups adapted by more intensively utilizing a variety of plant resources such as Indian rice grass. Plant processing equipment (ground stone and fire-cracked rock) appears after ~10,000 yr B.P. and dominates the archaeological record of the Holocene. Some economically important species (pinyon pine) became established; while others (bison) appear to have declined.

Campsites occupied by Archaic and more recent prehistoric populations (post-8000 yr B.P.) typically parallel the streams and are densely clustered near springs and wetlands on the valley floor. They are also commonly found in the pinyon-juniper woodlands on the mountain flanks and in rock shelters, adorned with rock art, along the western valley margin.

In summary, palynological analyses of lacustrine sediments from Como, San Luis and Head Lakes document changing climatic conditions in the San Luis Valley and adjacent Sangre de Cristo Mountains in postglacial times. Wide-spread climatic episodes, including the Younger Dryas, the Altithermal, the Medieval Warm Period, and the Little Ice Age appear to be represented and variably contributed to changing biotic communities, movements of upper treelines and lower ecotones, and fluctuations in pluvial lake levels. Present archaeological information suggests that there are greater frequencies of sites typologically dated to the Folsom portion of the Paleoindian period (~10,900-10,300 yr B.P.) and to the Middle and Late Archaic and Late Prehistoric Periods (~5000-450 yr B.P.) (Button, 1987). These apparent peaks in human population densities are coincident with intervals of more effective moisture and greater abundance of lacustrine resources. Fewer archaeological sites are attributed to the Late Paleoindian and Early Archaic periods (~10,000-5500 yr B.P.) when the lakes were either dry or at lower levels with higher salinity.

## Acknowledgments

Many thanks to David Shafer, Owen Davis and Jeanne De Lanois for their analyses of the San Luis Valley Lakes and for permission to reference unpublished data regarding *sporomiella* percentages.

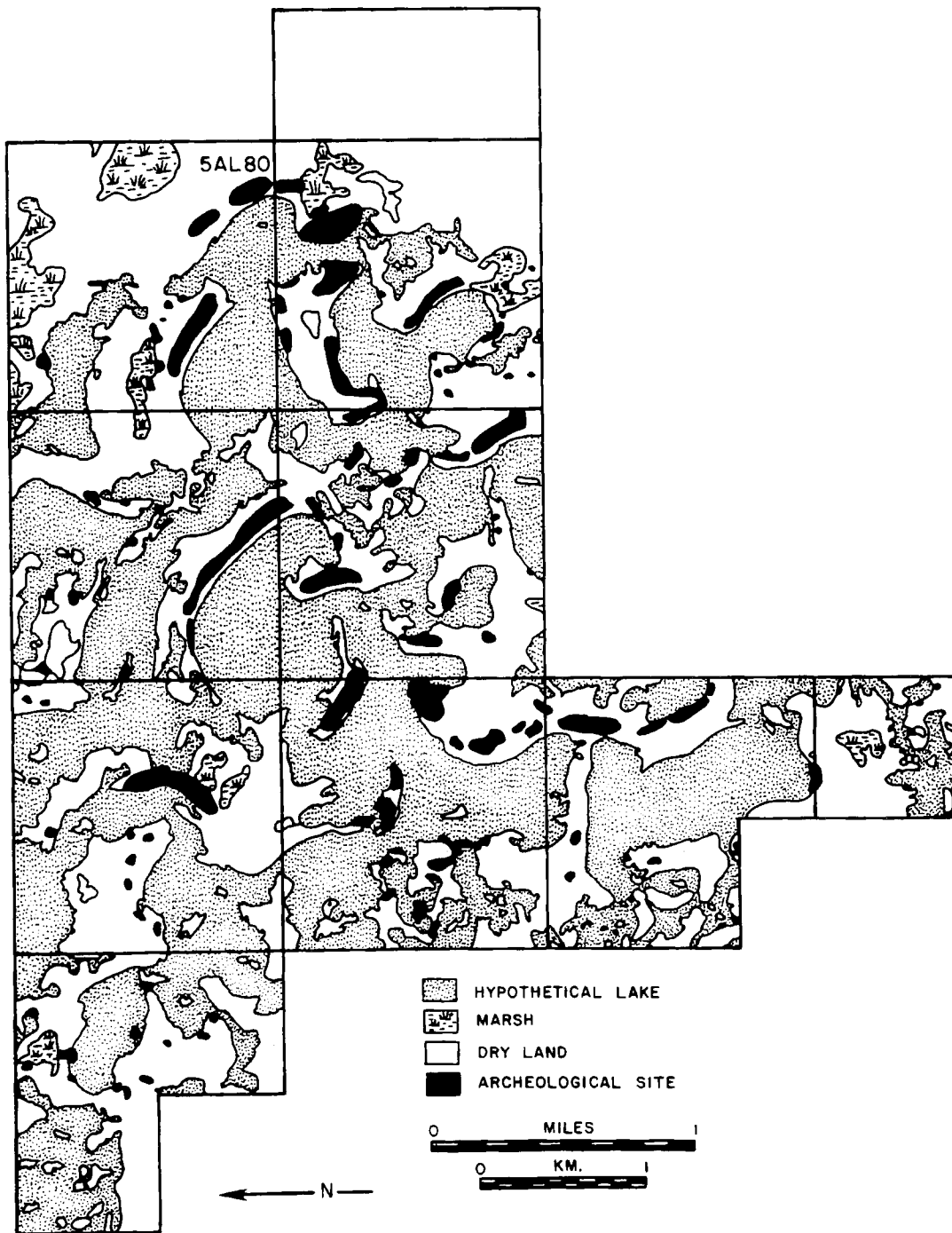

Figure 3 Distribution of recorded archaeological sites relative to lakeshore reconstruction for AD 280. Figure adapted from Jones, 1977, Figure 18.

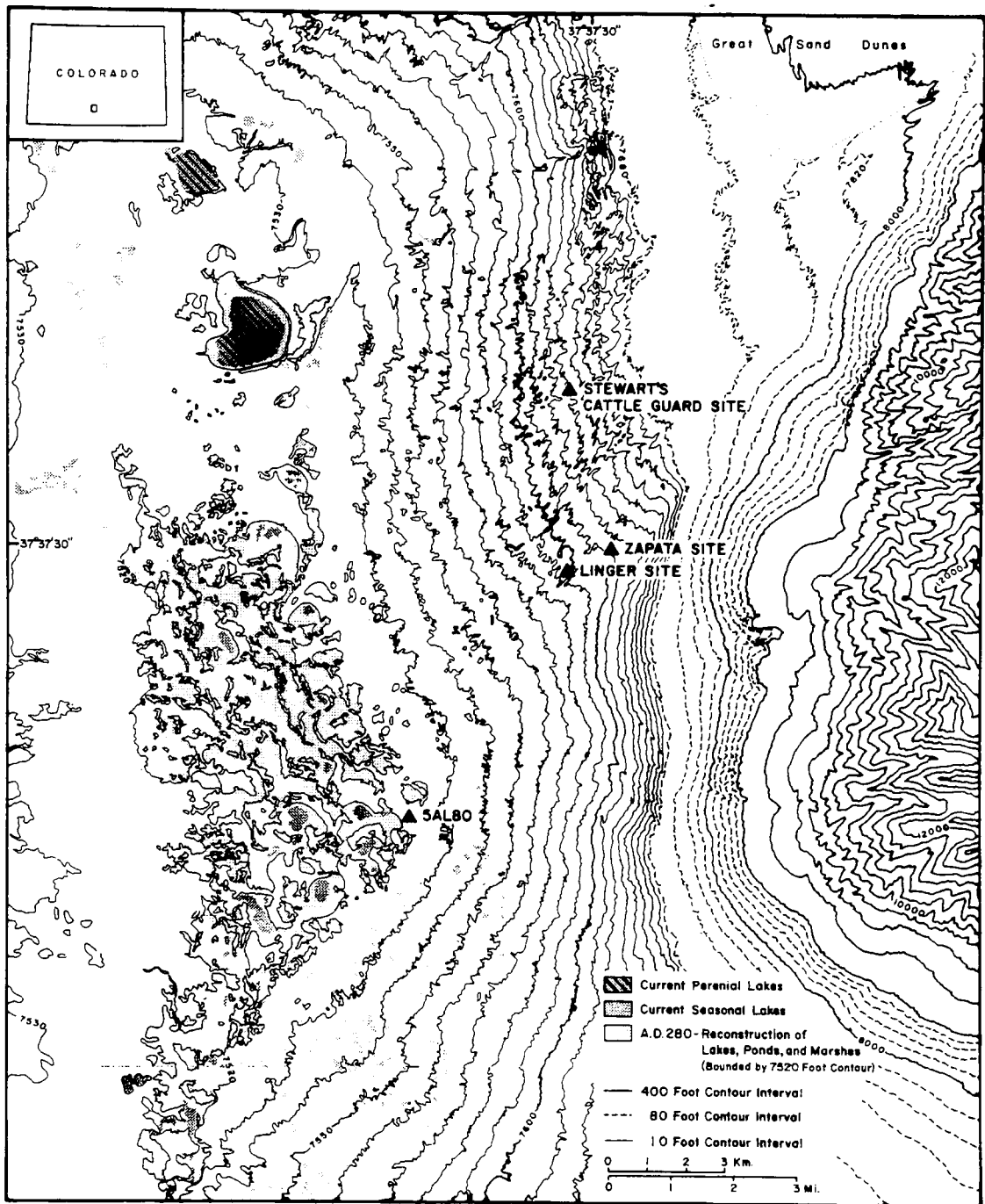

Figure 4 Topographic map showing A.D. 280 lake reconstruction relative to Folsom site locations.

## REFERENCES CITED

- Bachman, G.O. and Mehnart, H.H., 1978, New Kar dates and the late Pliocene to Holocene geomorphic history of the central Rio Grande region, New Mexico. *Geological Society of America Bulletin* 89::283-292.
- Benson, L., and Thompson, R.S., 1987, The physical record of lakes in the Great Basin. In Ruddiman, W.F. and Wright, H.E. Jr., eds, *The Geology of North America, Volume K-3: North America and Adjacent Oceans During the Last Deglaciation*, 241- 260.
- Bryson, R.A. and Bryson, R.U., 1995, Site-specific high-resolution climate models of Palaeoindian sites in the Plains: Hell Gap, Agate Basin, Alamosa, and Blackwater Draw. Paper presented at the Plains Anthropological Conference, Laramie.
- Button, V.Y., 1989, The Closed Basin of Colorado s San Luis Valley: Bureau of Reclamation Archeological Investigations 1976-86. U.S. Department of the Interior, Bureau of Reclamation.
- Chapin, R.K., 1971, The Rio Grande Rift, Part 1: Modifications and additions. In James, H.L., ed, *Guidebook of the San Luis Basin*, Colorado, New Mexico Geological Society, 191-210.
- Davis, O.K., 1987, Spores of the dung fungus *Sporomiella*: increased abundance in historic sediments and before Pleistocene megafaunal extinction. *Quaternary Research* 28:290-294.
- Davis, O.K., Agenbroad, L., Martin, P.S., and Mead, J.I., 1984, The Pleistocene dung blanket of Bechan Cave, Utah. *Special Publications of the Carnegie Museum of Natural History* 8:267-282.
- Davis, O.K. and Shafer, D.S., 1991, *Sporomiella*: An indicator of the Clovis-Folsom Biomass Collapse? Paper presented at the 56th Annual Meeting of the Society for American Archaeology, New Orleans. In Jodry, M.A. and Stanford, D.J., eds, *Folsom Archaeology: Terminal Pleistocene Paleoecology and Human Adaptation*, Smithsonian Institution Press, Archaeological Inquiry Series, in preparation.
- \_\_\_\_\_ 1992, A Holocene climatic record for the Sonoran desert from pollen analysis of Montezuma Well, Arizona, U.S.A , *Palaeogeography, Palaeoclimatology, and Palaeoecology* 92:107-119.
- Dawson, J. and Stanford, D., 1975, The Linger site: A reinvestigation. *Southwestern Lore* 41:22-28.
- De Lanois, J.L., 1993, Climatic Change During the Late Holocene from a South Central Colorado Lake, Master's Thesis, Department of Geosciences, University of Arizona, Tucson.
- Dick, H., 1975, A surface survey of Indian camps on the Blanca Wildlife Habitat, San Luis Valley, Colorado. Alamosa, Adam's State.
- Ferring, C.R., 1989, The Aubrey Clovis site: A Paleoindian locality in the upper Trinity River basin, Texas. *Current Research in the Pleistocene* 6:9-11
- Frison, G.C., ed, 1996, *The Mill Iron Site*. Albuquerque, University of New Mexico Press.
- Frison, G.C. and Todd, L.C., 1986, *The Colby Mammoth Site: Taphonomy and Archaeology of a Clovis Kill in Northern Wyoming*. Albuquerque, University of New Mexico Press.
- Forester, R.M., 1987, Late Quaternary paleoclimate records from lacustrine ostracodes. In Ruddiman, W.F. and Wright, H.E. Jr., eds, *The Geology of North America, Volume K-3: North America and Adjacent Oceans During the Last Deglaciation*, 261-276.
- Graham, R.W. and Kay, M., 1988, Taphonomic comparisons of cultural and noncultural faunal deposits at the Kimmswick and Barnhart sites, Jefferson County, Missouri. In Laub, R.S., Miller, N.G., and Steadman, D.W., eds, *Late Pleistocene and Early Holocene Paleoecology and Archeology of the Eastern Great Lakes Region*, Bulletin of the Buffalo Society of Natural Science, No. 33, 227-240.
- Haynes, C.V., Jr., 1987, Clovis origins update. *The Kiva* 52:83-93.
- \_\_\_\_\_ 1991, Archaeological and paleohydrological evidence for a terminal Pleistocene drought in North America and its bearing on pleistocene extinction. *Quaternary Research*:35:438-450.
- \_\_\_\_\_ 1992, Contributions of Radiocarbon Dating to the Geochronology of the Peopling of the New World. In Taylor, R.E., Long, A., and Kra, R.R., eds, *Radiocarbon After Four Decades, An Inter-*

- disciplinary Perspective*, New York, Springer-Verlag, 355-374.
- \_\_\_\_\_. 1993, Clovis-Folsom Geochronology and Climatic Change. In Soffer, O., and Praslov, N.D., eds, *From Kostenki to Clovis, Upper Paleolithic-Paleo-Indian Adaptations*, New York, Plenum Press, 219-236.
- Haynes, C.V., Beukens, R.P., Jull, A.J.T., Davis, O.K., 1992. New radiocarbon dates for some old Folsom sites: Accelerator technology. In Stanford, D.J., and Day, J.S., eds, *Ice Age Hunters of the Rockies*, Niwot, University Press of Colorado, 83-100.
- Hurst, C.T., 1943, A Folsom site in a mountain valley of Colorado. *American Antiquity* 8:250-253.
- Jodry, M.A., 1987, Stewart's Cattle Guard site: A Folsom site in southern Colorado, report of the 1981 and 1983 field seasons. Master's thesis, Department of Anthropology, University of Texas at Austin.
- \_\_\_\_\_. 1992, Fitting together Folsom: Refitted lithics and site formation processes at Stewart's Cattle Guard site. In Hofman, J.L. and Enloe, J.G., eds. *Piecing Together the Past: Applications of Refitting Studies in Archaeology*, British Archaeological Reports, International Series 578, 179-209.
- Jodry, M.A., Shafer, D.S., Stanford, D.J. and Davis, O.K., 1989, Late Quaternary environments and human adaptation in the San Luis Valley, south-central Colorado. In Harmon, E.J., ed, *Water in the Valley, A 1989 Perspective on Water Supplies, Issues, & Solutions in the San Luis Valley*. Colorado, Eighth Annual Field Trip, Colorado Water Association, 189-208.
- Jodry, M.A. and Stanford, D.J., 1992. Stewart's Cattle Guard site: An analysis of bison remains in a Folsom kill-butcher campsite. In Stanford, D.J., and Day, J.S., eds, *Ice Age Hunters of the Rockies*, Niwot, University Press of Colorado, 101-168.
- Jones, K.T., 1977, *Archaeological Test Excavations at the Blanca Wildlife Refuge in the San Luis Valley, Colorado*, Reports of the Laboratory of Public Archaeology No. 12, Fort Collins, Colorado State University.
- Kutzbach, J.E., 1987, Model simulations of the climatic patterns during the deglaciation of North America. In Ruddiman, W.F. and Wright, H.E. Jr., eds, *The Geology of North America, Volume K-3: North America and Adjacent Oceans During the Last Deglaciation*, 425-446
- Kutzbach, J.E., Guetter, P.J., Behling, P.J., and Selin, R., 1993, Simulated climatic changes: Results of the COHMAP climate-model experiments. In Wright et al., eds, *Global Climates Since the Last Glacial Maximum*, Minneapolis, University of Minnesota Press, 24-93.
- Peterson, W.S.B., and Hammer, C.U., 1987, Ice Core and other glaciological data. In Ruddiman, W.F. and Wright, H.E., Jr., eds, *Geological Society of America, Volume K-3: North America and Adjacent Oceans During the Last Deglaciation*, 91-110.
- Rogers, K.L., Larson, E.E., Smith, G., Katzman, D., Smith, G.R., Cerling, T., Wang, Y., Baker, R.G., Lohmann, K.C., Repenning, C.A., Patterson, P., and Mackie, G., (1992), Pliocene and Pleistocene geologic and climatic evolution in the San Luis Valley of south-central Colorado. *Palaeogeography, Palaeoclimatology, and Palaeoecology* 94:55-86.
- Rogers, K.L., Repenning, C.A., Forester, R.M., Larson, E.E., Hall, S.A., Smith, G.R., Anderson, E., and Brown, T.J., 1985, Middle Pleistocene (Irvingtonian:Nebraskan) climatic changes in South-Central Colorado. *National Geographic Research* 1:535-563.
- Shafer, D., 1989, The Timing of Late Monsoon Precipitation Maxima in the Southwest United States, Ph.D. Dissertation, Department of Geosciences, University of Arizona, Tucson. University Microfilms, Ann Arbor.
- Smith, G.I., and Street-Perrott, F.A., 1983, Pluvial lakes of the western United States. In Wright, H.E. Jr., ed, *Late Quaternary Environments of the United States*. In Porter, S.C., ed, *Volume 1, The Late Pleistocene*, Minneapolis, University of Minnesota Press, 190-214.
- Stanford, D.J., 1990, A history of archaeological research in the San Luis Valley, Colorado. *The San Luis Valley Historian* 22(3):33-39.
- Stuiver, M. and Becker, B., 1986, High-precision decadal calibration of the radiocarbon time scale, A.D. 1950-2500 B.C. *Radiocarbon* 28:863-910.



# GENERAL GEOLOGY OF THE NORTHERN SAN LUIS VALLEY, COLORADO

James P. McCalpin

GEO-HAZ Consulting  
P.O. Box 1377  
Estes Park, CO 80517



## INTRODUCTION

The San Luis Valley (SLV) of south-central Colorado is a major physiographic and structural element of the Rio Grande rift. The valley measures 75 km wide (east-west) and 160 km long (north-south) with an average floor elevation of ca. 2440 m. It is flanked by the San Juan Mountains (to the west) and the Sangre de Cristo and Culebra Ranges (to the east), both of which contain peaks higher than 4270 m (Fig. 1). This paper describes the general geology of the northern part of the valley from Poncha Pass at its north end to approximately the latitude of Alamosa, Colorado.



Fig. 1. Winter view of the eastern Alamosa Basin and Sangre de Cristo Range, looking southeast toward Crestone. Highest peaks are Crestone Peak (left, elevation 4319 m) and Kit Carson Peak (right, elevation 4317 m).

## GEOMORPHOLOGY AND CLIMATE

Physiographically, the SLV can be divided into four subsections (Fig. 2; from Upson, 1939): 1) the Alamosa Basin, which includes all of the internally-drained basin north of the San Luis Lakes, as well as the giant alluvial fan of the Rio Grande River northwest of Alamosa, 2) the Culebra reentrant, a

piedmont at the base of the Culebra Range in the

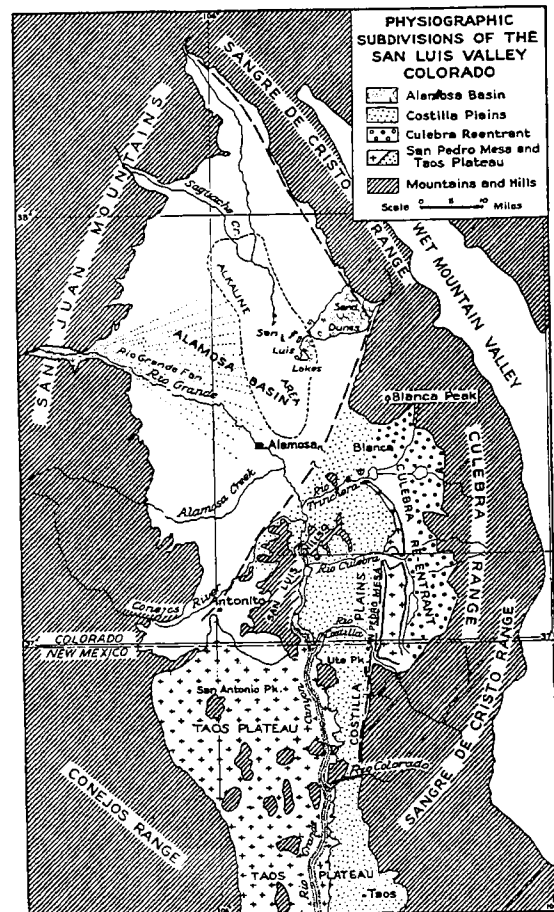

Fig. 2. Physiographic subdivisions of the San Luis Valley, from Upson (1939).

southeastern part of the valley, 3) the Costilla Plains, an old valley floor east of the incised channel of the Rio Grande River, and 4) the Taos Plateau, a volcanic bench located almost entirely in New Mexico. In this paper I discuss only the Alamosa Basin, which is the largest subsection by area. The northernmost arm of the Alamosa Basin was named

the Villa Grove reentrant by Knepper and Marrs (1971).

Although two large perennial streams (Saguache Creek and San Luis Creek) traverse the northern Alamosa Basin, dissection of the valley floor is negligible. A well-developed bajada exists along the base of the Sangre de Cristo Range and most streams from this range sink into alluvial fans rather than connecting to San Luis Creek (Figs. 3, 4).



Fig. 3. View down the glaciated valley of Willow Creek, immediately north of Kit Carson Peak, looking west toward the valley floor and the Baca Grande land grant. In center foreground is Willow Park, an infilled lake basin impounded behind latest Pleistocene glacial moraines. Streams such as Willow Creek and the Crestone Creeks traverse glaciofluvial fans, only to sink into the valley floor.



Fig. 4. View looking upstream (north) up the braided channel of Medano Creek, at the Great Sand Dunes National Monument. The active dune field is at left. Medano Creek is renowned for its surging flow during the spring runoff season (Schumm et al., 1982). During peak flow (ca. 50 cfs at the range front), the creek flows for about 8 km before it sinks into the valley floor.

At the low point in the basin, the San Luis Lakes comprise a hydrologic sump, separated by a low

topographic divide from the Rio Grande drainage basin to the south. Sandy basin fill around the sump area has been mobilized as eolian sand, which has been transported northeast and piled up into the 185 m- high dunes (Fig. 5) of the Great Sand Dunes National Monument (Johnson, 1967).

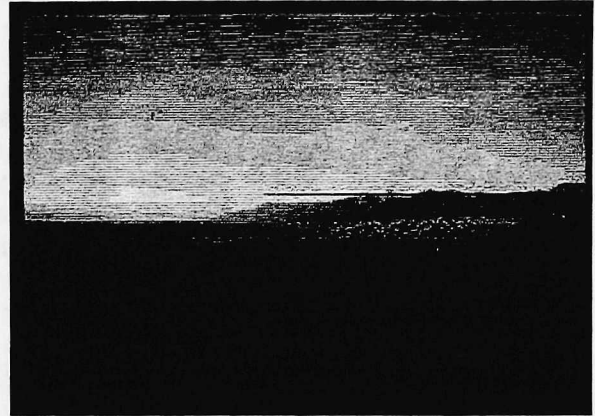

Fig. 5. Dunes in the Great Sand Dunes National Monument (right center) rise 185 m above the valley floor, and are a result of southwesterly winds funneling through Medano and Mosca Passes (out of sight to right). High peaks of the Crestone group are visible above the dunes, and the Villa Grove reentrant is visible in the distance at left center. Photo was taken from the head of the North Zapata alluvial fan, looking north.

The steep, linear range front of the Sangre de Cristo Range exhibits well-developed faceted spurs, indicative of active uplift (Peterson, 1979; McCalpin, 1982). On the west (hinged) side of the valley, foothills of the San Juan Mountains descend more gradually to the valley floor.

Strong gradients of temperature and precipitation exist between the valley floor and flanking ranges. Precipitation falls largely as winter snow or late summer (monsoonal) thunderstorms. Annual precipitation ranges from 178 mm/yr on the valley floor to 1016 mm/yr on the higher peaks. Mean monthly temperatures at Alamosa, in the basin center, range from  $-8^{\circ}\text{C}$  in January to  $18^{\circ}\text{C}$  in July, with extremes of  $-40^{\circ}\text{C}$  to  $+38^{\circ}\text{C}$  recorded. In general, potential evapotranspiration (ET) exceeds precipitation (P) in the valley, while the reverse is true in the mountains. The  $P=ET$  boundary lies approximately at the pinyon-juniper/pine forest boundary, which is often equivalent to the base of the range front. Due to strong meteorologic gradients, the valley and surrounding mountains contain ecozones ranging from Upper Sonoran

(greasewood and rabbitbrush) on the valley floor to Alpine tundra above elevations of ca. 3810 m.

In this paper, I first describe the stratigraphy of Precambrian, Paleozoic, and Cenozoic rocks exposed in the flanking ranges, and then make some inferences on basin fill stratigraphy based on indirect data. Structural geology will then be likewise described.

### PREVIOUS WORKS

Geologic mapping in the San Luis Valley area has occurred in sporadic episodes, often associated with specific research programs of universities and the U.S. Geological Survey. Early regional works include Siebenthal (1910), Burbank and Goddard (1937), Gableman (1952), and Litsey (1958). Thesis mapping in the Sangre de Cristo Range began at the University of Colorado (Boulder) in the 1950's (Toulmin, 1953; Litsey, 1954; Munger, 1959), at the Colorado School of Mines in the 1960's (Koch, 1963; Karig, 1964; Nolting, 1970; Wychgram, 1972; Knepper, 1974), and at other universities (e.g. Volckmann, 1965; Peterson, 1979; Reynolds, 1986). Subsurface thesis studies in the basin (geophysics, hydrogeology) include Gaca (1965), Gaca and Karig (1966), Stoughton (1977) and Huntley (1977, 1979a, 1979b). Thesis students also mapped volcanic rocks in the mountains west of the valley, particularly the Bonanza volcanic field on the western side of the Villa Grove reentrant (Bridwell, 1968; Kauther, 1968; Mayhew, 1969; and Perry, 1971), building on the early works of Pattern (1915) and Burbank (1932) in the Bonanza mining district. These thesis studies supplemented more regional volcanic studies (Lipman and Mehnert, 1970, 1975). For several decades some of the best geologic syntheses for the San Luis Valley existed only in field trip guidebooks (e.g. James, 1971; Huntley, 1976a, 1976b; Hawley, 1978) or in conference proceedings (Tweto, 1975, 1979).

A shorter hiatus in the 1970's was terminated by studies of the U.S. Geological Survey in support of wilderness designation of the bulk of the Sangre de Cristo Range (Johnson et al., 1974). These studies resulted in regional-scale (Johnson et al., 1987) and 1:24,000-scale mapping of the Sangre de Cristo Range (Lindsey et al., 1984, 1985a, 1985b, 1987; Lindsey and Soulliere, 1987; Bruce and Johnson, 1991; Johnson et al., 1989; Johnson and Bruce, 1991).

A third episode of applied studies began in the late 1980's, fueled by a controversial water development project (Harmon, 1991) and subsequent exploration for minerals and petroleum in the eastern part of the

basin (Gries, 1985; Gries and Brister, 1989; Brister and Gries, 1994; Watkins, this volume).

## STRATIGRAPHY

### Precambrian Rocks

Precambrian igneous and metamorphic rocks form the basement of both the San Luis Valley and flanking uplifts. In the Bonanza-Kerber Creek area, fine-grained biotite granite occurs in the cores of the central and eastern anticlines (Burbank, 1932), whereas the upper plates of the Kerber and Noland faults are composed of foliated porphyritic granite. Farther north in the southern Sawatch Range, an older suite of Precambrian high-grade metamorphic rocks (quartz-mica schist, amphibolite gneiss, and quartz-feldspar gneiss) are locally intruded by granite and pegmatite dikes, probably correlative with the Bonanza granites. In the Sangre de Cristo Range Precambrian rocks are exposed in the upper plates of Laramide thrusts along the western side of the range. These rocks are divided into four groups by Lindsey et al. (1984, 1985a); three of lower Proterozoic age (1.7-1.8 Ga) (gneiss, leucogneiss, and quartz monzonite), and a younger (middle Proterozoic, 1.4 Ga) quartz monzonite that locally intrudes the metamorphic rocks.

### Paleozoic Rocks

Paleozoic rocks in the northern SLV comprise a relatively thin sequence of lower Paleozoic shelf clastics and carbonates, overlain by a thick sequence of late Paleozoic coarse clastics deposited in a rapidly-subsiding basin (Fig. 6).

The Cambrian Sawatch Quartzite is the oldest sedimentary rock unit and locally overlies a low-relief erosion surface cut on Precambrian gneiss. However, in most of the region the Ordovician Manitou Formation (dolomite 27-68 m thick) forms the base of the sedimentary section and directly overlies Precambrian rocks. Disconformably overlying the Manitou Formation are the Harding Sandstone (fine-medium grained quartz sandstone, 18-35m thick) and the Fremont Formation (dolomite, 70-91 m thick), both of Ordovician age. No Silurian strata are preserved in the area; this stratigraphic break is the largest gap in the pre-Pennsylvanian sedimentary record (Litsey, 1958, p. 1154)

Devonian and Mississippian rocks of the Sangre de Cristo Range are comparable in thickness to the lower Paleozoic rocks, and include the Devonian Chaffee Formation (with a 3 to 19 m thick quartzite member and a 26 to 38 m thick dolomite member)

AGE	FORMATION	THICKNESS	DESCRIPTION
CENOZOIC			Glacial gravel and alluvium
PENN AND PERMIAN	SANGRE DE CRISTO FORMATION	6500'	Arkosic conglomerate interbedded with red micaceous sandstone and thin limestones
PENNSYLVANIAN AND PERMIAN (?)	MINTURN FORMATION	8000'	Drab sandstones and fine conglomerates interbedded. All are massive. Thin limestone at top.
PENN	KERBER FORMATION	0-150'	Sandstone and coaly shale
MISSISSIPPIAN	LEADVILLE LIMESTONE	238-336'	Limestone, massive, medium gray. Contains black chert nodules
DEVONIAN	CHAFFEE FORMATION	Dyer dolomite mem.	Dolomite, fine-grained, almost lithographic, weathers grayish yellow.
		Porting quartzite mem.	Quartzite and sandy shale.
ORDOVICIAN	THIMMONT THIMMONT	196'-283'	Dolomite, thick bedded or massive, medium gray, somewhat fossiliferous
	HANGING SANDSTONE	65'-116'	Quartzite, thick to thin-bedded, soft shaly zone at base. Fish scales at top
	MANitou FORMATION	121'-197'	Dolomite, crystalline, weathers medium light gray or yellowish gray. Layers of chert common
PRE CAMBRIAN	CRYSTALLINE ROCKS		Hornblende gneiss and quartz biotite gneiss intruded by granite

Fig. 6. Stratigraphic column of the northern Sangre de Cristo Range, from Litsey (1958).

and the Mississippian Leadville Limestone (a massively bedded blue to gray limestone, 64-102 m thick in this area).

Pennsylvanian and Permian rocks in the region reflect a major change in sedimentation style associated with the Ancestral Rockies orogeny. The northern San Luis Valley was located in the central Colorado trough between two northwest trending uplifts (the Uncompahgre highland to the west and the Front Range highland to the east). The oldest Pennsylvanian rocks deposited in this trough are fine-grained clastic rocks and limestones, but younger rocks contain vast volumes of very coarse clastics of granitic provenance. The Permo-Pennsylvanian section begins with the Kerber Formation (stratigraphically equivalent to the Belden Formation of central Colorado), about 60 m of coarse sandstone and carbonaceous shale that overlies the Leadville Limestone. The Kerber Formation is overlain by the 2440 m thick Minturn Formation (Pennsylvanian and Permian?). Litsey (1958) informally subdivides this formation into a basal gray quartzose to micaceous sandstone (122 m thick), interbedded red to gray sandstones and conglomerates (365 m thick), olive to brown sandstone with thin shales, siltstones, and

conglomerates (1737 m thick), and an upper 213 m of gray limestone and brown sandstone (Lindsey et al., 1985; Clark and Walz, 1985).

The most distinctive Paleozoic formation, which crops out over most of the Sangre de Cristo Range, is the Sangre de Cristo Formation (Pennsylvanian-Permian; equivalent to the Maroon Formation of central Colorado). The formation ranges from 1676 to 2930 m thick, and is dominantly composed of cyclotherms in piedmont-facies alluvium, with a basal arkosic conglomerate grading upward to finer sandstones and local nodular limestones. A very coarse-grained lens, the Crestone Conglomerate (Fig. 7), contains boulders up to 10 m in diameter and represents proximal alluvial fan material derived from the Uncompahgre highland to the west (Lindsey et al, 1986).



Fig. 8. The U-shaped valley of Willow Creek (center) was carved by glaciers through the resistant strata of the Crestone Conglomerate. The aspen-fringed meadow at lower right is Willow Park, a moraine-dammed lake basin (also seen in Fig. 3).

The reference section for this formation is described by Lindsey and Schaefer (1984). Subeconomic deposits of copper and uranium occur in the Permo-Pennsylvanian section (Lindsey and Clark, 1995).

### Mesozoic Rocks

Previous mappers failed to find any preserved Mesozoic rocks in the Sangre de Cristo Range (e.g. Burbank and Goddard, 1937; Litsey, 1958), and their absence was also inferred beneath the SLV. Based on the presence of Mesozoic rocks in adjacent basins, Litsey concluded that "During the Mesozoic sediments were undoubtedly deposited in the northern Sangre de Cristo Mountains, but they were removed by erosion during and following Laramide uplifts" (Litsey, 1958, p. 1172-1173). Subsequent workers (e.g. Tweto, 1975) accepted this conclusion,

but recent discoveries of Mesozoic strata on the piedmont near Crestone (Watkins, this volume) may force reappraisal of this conclusion, and its implications for a Laramide highland at the present site of the San Luis Valley (see Structure section).

### **Cenozoic Rocks**

Cenozoic rocks include volcanic flows and tuffs exposed in the mountains west of the valley, mid-Tertiary intrusives in high flanking ranges, and thick basin fill sediments beneath the valley floor. In the Bonanza volcanic field Oligocene andesites, rhyolites, latites, tuffs, and breccias cover most of the mountain range, and have an aggregate thickness of 1341-2470 m. Similar volcanic rocks farther south, along the western margin of the valley and in the San Luis Hills south of Alamosa, belong to the Conejos Formation. Basal flows have been dated by Lipman et al. (1970) at 33.4-34.2 Ma.

Contemporaneous with volcanism was the intrusion of dikes, sills, and stocks in the Bonanza caldera and in the northern Sangre de Cristo Range (Rio Alto and Slide-Rock Mountain stocks). These intrusives yield ages of 25.8 to 32.8 Ma according to fission tracks (Lindsey et al., 1986).

Cenozoic basin fill deposits are poorly exposed because there has been minimal dissection into the valley floor. However, an increasing number of oil test wells and geophysical transects made in the past two decades permit a relatively detailed characterization of the basin fill in some areas. The basal valley fill is pre-volcanic redbeds encountered in the bottom of drill holes in the western part of the valley (Monte Vista graben), where they directly overlie Precambrian basement. The redbeds range from nearly 700 m thick in the center of the Monte Vista graben to 115 m thick on the Alamosa horst, and form an eastward-thinning wedge that may extend as far as the eastern basin margin. The taper of this wedge does not appear to be affected by the presence of the Alamosa horst, and thus this formation is presumed to predate the formation of major rift normal faults. Brister and Gries (1994) correlate these redbeds to the Blanco Basin Formation (Eocene), which outcrops on the southwestern flank of the San Juan Mountains. In contrast, Huntley (1979a) and Burroughs (1981) correlated these redbeds to the Vallejo Formation of Upson (1941), which outcrops in small fault-bounded slivers in the Culebra reentrant.

These Paleocene (?) to Eocene (?) redbeds are overlain by an eastward-thinning wedge of volcanic and volcanoclastic rocks of the Oligocene Conejos Formation. The Conejos Formation (30-35 Ma) is a

series of intermediate-composition volcanoclastic rocks and lava flows derived from the San Juan volcanic field west of the SLV. Like the underlying redbeds, the eastward-tapering wedge of Conejos volcanics does not appear to be controlled by rift normal faults, and thus predates rift formation.

Overlying the Conejos Formation is a series of 26-30 Ma ash-flow tuffs derived from volcanic centers west of the SLV. These distinctive welded tuffs form a recognizable subsurface stratigraphic marker between the pre-rift redbeds and Conejos Formation, and the overlying, post-rift Santa Fe Formation (Brister and Gries, 1994, this volume).

Overlying the ash flow tuffs is the bulk of the basin fill, which previous workers have assigned to the Miocene-Pliocene Santa Fe Formation (equivalent to the Dry Union Formation of the upper Arkansas Valley and the Los Pinos Gravel of the San Juan Mountains). Most of the Santa Fe Formation logged in boreholes is sandy, similar to the sandy sediments accumulating on the basin floor today. Only near the steep Sangre de Cristo Range front are coarser conglomerates encountered. The Santa Fe Formation varies in thickness according to its position within the present graben, being as thin as 250 m over the Alamosa horst and up to 3100 m thick in the axis of the Baca graben (Brister and Gries, 1994, this volume).

Quaternary deposits have been mapped within the Sangre de Cristo Range and piedmont (McCalpin, 1982) and studied in the valley floor exposures (Rogers et al., 1992). The uppermost valley floor fill was defined as the Alamosa Formation by Siebenthal (1910) and its upper 20 m is exposed in Hansen's Bluff, an old fluvial (?) scarp about 8 km east of Alamosa. According to Rogers et al (1992), this section of alternating sands and silts is of mixed fluvial, lacustrine, and eolian origin, and reflects closed-basin deposition on the valley floor before ca. 600 ka, when the Rio Grande River was integrated to drainage farther downstream and became entrenched into the valley floor.

Subsequent to 600 ka, deposition has been limited to eolian reworking of valley floor deposits, and to alluvial fan deposition along the Rio Grande River and the bajada at the base of the Sangre de Cristo Range. Many of the Sangre de Cristo alluvial fans can be traced to terminal moraines at, or slightly upstream of, the range front, suggesting that they are mainly glacial outwash features (see Fig. 3). In contrast, Holocene deposition has been restricted to narrow stream channels and low-terraces that comprise <5% of the surface area of the northern basin. In general, alluvial fan surfaces become older

and more dissected going north in the Villa Grove reentrant, which suggests that the basin is not subsiding as rapidly at its northern end.

### STRUCTURE

The San Luis Valley has been the site of repeated orogenesis since Pennsylvanian, and perhaps Precambrian, time. The elevated basin floor and lofty rift-margin uplifts of today are merely the latest manifestation of vertical tectonics that includes the Ancestral Rockies orogen (Pennsylvanian) and Laramide orogeny (Late Cretaceous-Eocene). Even older orogenies may be represented by the isoclinal folding of foliations in Precambrian metamorphic rocks. Several previous workers (Tweto, 1975, 1979; Knepper, 1974) have speculated that movement in each orogeny takes advantage of high angle faults and shears created in earlier orogenies, perhaps dating back to the Precambrian.

No faults in the study area can be shown to have experienced significant vertical displacement in the Ancestral Rockies orogeny. However, on the eastern flank of the Sangre de Cristo Range near Howard, Colorado, the bounding reverse fault of the Front Range-Apishapa highland (the Pleasant Valley fault) displaced Precambrian basement as much as 300 m and folded the lower Paleozoic strata into a series of NW-trending anticlines and synclines. Kluth (1986) discusses the plate tectonic of this orogeny.

Most of the prominent faults and folds exposed in the Sangre de Cristo Range date from the Laramide orogeny (Late Cretaceous-middle Eocene or ca. 65-55 Ma) (Tweto, 1975). The SLV occupies the site of the former San Luis-Brazos uplift, a broad area of crustal upwarping and high-angle reverse faulting. Major west-dipping reverse faults exposed in the Sangre de Cristo Range are (from west to east) the Crestone, Sand Creek, Deadman, and Spread Eagle thrusts. The eastern margin of the range is marked by the east-dipping Alvarado fault system, about which little is known. South of Valley View Hot Springs the Crestone thrust turns west and is truncated by the range-front Sangre de Cristo normal fault. A similar south-dipping thrust on the west side of the Villa Grove reentrant, the Kerber Creek fault, has been postulated as the continuation of the Crestone thrust.

The Crestone and Sand Creek thrusts have shoved Precambrian basement up and eastward over late Paleozoic rocks, typically the Sangre de Cristo Formation. According to Litsey (1958) the Crestone Thrust is a complex fault zone at least 800 m wide that contains numerous fault slivers of pre-Pennsylvanian sedimentary rocks. Mylonite, slaty

cleavage, and chloritoid phyllite mark the thrust footwall (Lindsey et al., 1986). Thrusts farther east are within the upper Paleozoic section and are separated by the NW- to NNW-trending anticlines and synclines that typify the range.

Following the Laramide orogeny the San Luis-Brazos uplift was eroded to low relief and the widespread Eocene erosion surface (Epis and Chapin, 1975) evidently formed across the SLV. This erosion surface is preserved in the subsurface as an unconformity between the Eocene (?) redbeds and the overlying Oligocene Conejos Formation (Brister and Gries, 1994, this volume).

### Rift-Related Structures

The present topography of the San Luis Valley and margins is a direct expression of post-Oligocene displacements on normal faults of the Rio Grande Rift. The valley displays classical rift structure, with a valley flanked by raised rift shoulders (Eaton, 1987). In a gross sense, the valley is an east-tilted half graben, with major boundary fault(s) at the base of the Sangre de Cristo Range, and a broad hinge on the western valley margin. Drilling and geophysics have documented a buried intrarift horst (the Alamosa horst) with no surface expression in the Alamosa Basin, but which surfaces farther south as the San Luis Hills. This horst divides the basin into two subbasins, an east-tilted western one with up to 3027 m of post-Eocene sediments (the Monte Vista graben), and a deeper narrow eastern one (the Baca graben) with up to 5000 m of sediments. On the Alamosa horst, basin fill thins to 1650 m.

The eastern margin normal fault, named the Sangre de Cristo fault by Litsey (1958), lies at the base of the steep linear range front of the Sangre de Cristo Range. Steep gravity gradients indicate that the fault is either a single steeply-west-dipping fault (Tweto, 1979) or a narrow belt of step faults (Kluth and Schaftenaar, 1994). Fission tracks suggest that the Sangre de Cristo Range was rapidly uplifted about 19 Ma, although total uplift to date has not exceeded ca. 4 km (Lindsey et al., 1986). These dates are compatible with the observation of Scott and Taylor (1975) that volcanic flows dated at 19.5 Ma crossed unimpeded from west to east across the present site of the northern Sangre de Cristo Range. Late Miocene to recent uplift is responsible for the ca. 2 km of present relief on the range (Lindsey et al., 1986), and continuing uplift is evidenced by multiple-event fault scarps (Fig. 8) that offset Quaternary deposits and landforms of diverse ages (McCalpin, 1982). Fault scarp profiling and trenching suggest: 1) average vertical displacement



Fig. 8. A typical fault scarp across an alluvial fan surface along the Sangre de Cristo fault zone. The scarp is located at Uracca Creek on the western edge of the Blanca Peak massif, is 9.3 m high, and has a maximum scarp slope angle of 23 degrees.

per faulting event is 1.2-2.9 m, 2) long-term return times for  $M > 7$  earthquakes are 10-47 kyr, and 3) the latest two  $M > 7$  paleoearthquakes occurred about 10-13 ka and 7.6 ka. Based on these data, the Sangre de Cristo fault has experienced Holocene displacement and is thus one of Colorado's few active faults by common definition (Kirkham and Rogers, 1981). Colman et al. (1983) show young faults and Quaternary deposits in this area.

A 10 km-long splay of the Sangre de Cristo fault, termed the Villa Grove fault zone by Knepper (1974), trends northwest across the valley floor between Valley View Hot Springs and Villa Grove (Figs. 9, 10).

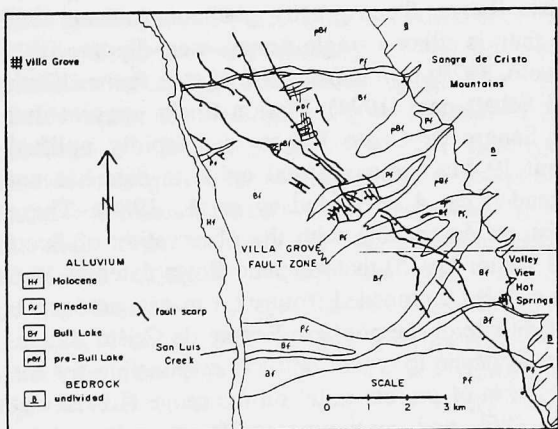

Fig. 9. Simplified geologic map of the Villa Grove fault zone, from McCalpin (1982).

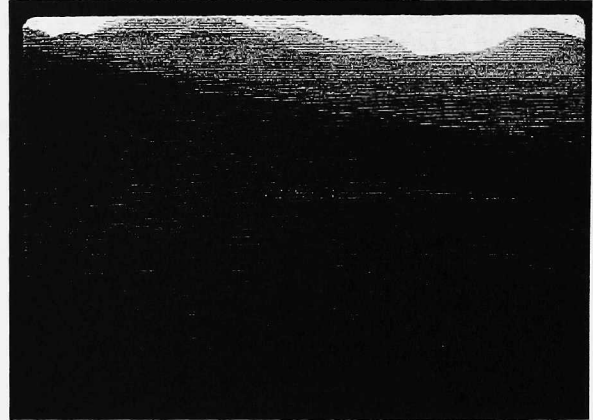

Fig. 10. The largest fault scarp in the Villa Grove fault system trends across the photo at center, after splaying off the range front Sangre de Cristo fault zone (off the photo to right). At this location the scarp is 8.2 m high and has a maximum scarp slope angle of 27 degrees.

The trace is thus close to the subbasin projection of the Crestone thrust to the Kerber Creek thrust and may represent an extensional reactivation of that buried Laramide structure. Scarps of the Villa Grove fault zone range from 0.3 - 14 m high, and were created by discrete displacements of 0.8 - 1.4 m with return times of 30-100 kyr. The latest surface-rupturing earthquake occurred after ca. 13 ka, but its exact age is unknown.

The two flanking faults of the Alamosa horst have not created fault scarps on the valley floor. At several locations in the northern valley vague vegetation lineaments follow the inferred fault trace, possibly the result of groundwater anomalies. Mineral Hot Springs is located astride the eastern horst-bounding fault, and extensive mounds have travertine mark the fault trace. However, there is no evidence for late Quaternary movement on those faults.

The western basin margin is generally described as a broadly warped hinge zone, but several short (10 km long) east- and west-facing fault scarps disrupt mid-Pleistocene pediment surfaces west of Monte Vista (Lipman, 1976). These scarps, although striking on aerial photographs, are very broad and gentle, with scarp heights of 2-7 m, maximum scarp slope angles of  $3^{\circ}$ - $9^{\circ}$  and estimated ages of ca. 13-500 ka based on the diffusion dating technique for scarp profiles (McCalpin, unpub).

The Holocene and late Quaternary faults in the San Luis Valley are not associated with any recorded historic seismicity (Hadsell, 1968). In fact, in 120 years of recorded history only one felt

earthquake has originated in the valley (on 10-07-1952, MMI V, @ 37°N, 106°W; Stover et al., 1988). Keller and Adams (1976) were unable to detect any earthquakes > M 1.5 during a brief microearthquake survey. However, a lack of historic seismicity in areas of late Quaternary (and even Holocene) faulting is typical in much of the Basin and Range Province. For example, the 1983 Ms 7.3 Borah Peak earthquake occurred in the Lost River Valley of central Idaho, an area with no recorded historic seismicity. Based on scarp heights and trench data, the Sangre de Cristo fault has generated earthquakes of Ms 6.8-7.4 in the past.

#### REFERENCES

- Bridwell, R. J., 1968, Geology of the Kerber Creek area, Saguache County, Colorado: M.S. Thesis 1367, Colorado School of Mines, Golden.
- Brister, B.S. and Gries, R.R., 1994, Tertiary stratigraphy and tectonic development of the Alamosa Basin (northern San Luis Valley), Rio Grande rift, south-central Colorado, in Keller, G.R. and Cather, S.M. (eds.), Basins of the Rio Grande Rift; Structure, Stratigraphy, and Tectonic Setting: Geol. Soc. Amer. Spec. Paper 291, p. 39-58.
- Bruce, R. M. and Johnson, B. R., 1991, Reconnaissance geologic map of parts of the Zapata Ranch and Mosca Pass quadrangles, Alamosa and Huerfano Counties, Colorado: U.S. Geological Survey Map MF-2168, scale 1:24,000.
- Burbank, W. S., 1932, Geology and ore deposits of the Bonanza Mining district, Colorado: U.S. Geological Survey Professional Paper 169, 166 p.
- Burroughs, R.L., 1981, A summary of the geology of the San Luis Basin, Colorado and New Mexico, with emphasis on the geothermal potential for the Monte Vista graben: Colo. Geol. Surv. Spec. Pub. 17, 30 p.
- Clark, R. F. and Walz, D. M., 1985, Stratigraphic section, depositional environments, and metal content of upper part of Mid-Pennsylvanian Minton Formation, Sangre de Cristo Range, Custer and Saguache Counties, Colorado: U.S. Geological Survey Map MF-1622-D.
- Colman, S.M., McCalpin, J.P. Ostenaar, D.A. and Kirkham, R.M., 1985, Map showing upper Cenozoic rocks and deposits and Quaternary faults, Rio Grande rift, south-central Colorado: U.S. Geol. Surv. Map I-1594, scale 1:125,000.
- DeVoto, R. H., Peel, F. and Pierce, W. H., 1971, Pennsylvanian and Permian stratigraphy, tectonism, and history, northern Sangre de Cristo Range, Colorado, in James, H. L. (ed.), Guidebook of the San Luis Basin, Colorado: New Mexico Geological Society Guidebook, 22nd Field Conference, p. 141-163.
- Eaton, G. P., 1987, Topography and origin of the southern Rocky Mountains and Alvarado Ridge, in Coward, M. P., Dewey, J. F., Hancock, P. L. (eds.), Continental extensional tectonics: Geological Society of London Special Publications, vol. 28, p. 355-369.
- Epis, R.C. and Chapin, C.E., 1975, Geomorphic and tectonic implications of the post-Laramide, late Eocene erosion surface in the southern Rocky Mountains, in Curtis, B.F. (ed.), Cenozoic history of the Southern Rocky Mountains: Geol. Soc. Amer. Memoir 144, p. 45-74.
- Gableman, J. W., 1952, Structure and origin of northern Sangre de Cristo Range, Colorado: American Association of Petroleum Geologists Bulletin 36, p. 1547-1612.
- Gaca, J. R., 1965, Gravity studies in the San Luis Valley area, Colorado: M.S. Thesis 1021, Colorado School of Mines, 73 p., Golden.
- Gaca, J. R. and Karig, D. E., 1966, Gravity survey of the San Luis Valley area, Colorado: U.S. Geological Survey Open-File Report, 21 p.
- Gries, R., 1985, Seismic lines in the San Luis Valley, south-central Colorado, in Gries, R.R. and Dyer, R.C. (eds.), Seismic exploration of the Rocky Mountain region: Rocky Mountain Assoc. of Geologists and Denver Geophysical Society, p. 267-274.
- Gries, R. and Brister, B.S., 1989, New interpretations of seismic lines in the San Luis Valley, south-central Colorado, in Harmon, E.J. (ed.), Water in the Valley: Colo. Ground-Water Assoc., 8th Annual Field Trip Guidebook, Denver, CO, p. 241-254.
- Hadsell, F. A., 1968, History of earthquake activity in Colorado: Colorado School of Mines Quarterly 63 (1), p. 57-72, Golden.
- Harmon, E.J. (ed.), 1989, Water in the Valley: Colo. Ground-Water Assoc., 8th Annual Field Trip, Guidebook, Denver, CO..

- Hawley, J. W. (comp.), 1978, Guidebook to the Rio Grande-rift in New Mexico and Colorado: New Mexico Bureau of Mines and Mineral Resources Circular 163, 241 p.
- Huntley, D., 1976a, Field trip, northern San Luis Valley, Colorado, *in* Epis, R. C. and Weimer, R. J. (eds.), Studies in Colorado field geology: Colorado School of Mines Professional Contributions 8, p. 523-538, Golden.
- Huntley, D., 1976b, Hydrogeology of northern San Luis Valley, *in* Epis, R. C. and Weimer, R. J. (eds.), Studies in Colorado field geology: Colorado School of Mines Professional Contributions 8, p. 523-538, Golden.
- Huntley, D., 1979a, Cenozoic faulting and sedimentation in northern San Luis Valley, Colorado: Summary: Geol. Soc. Amer. Bull. 90, pt. 1, p. 8-10.
- Huntley, D., 1979b, Cenozoic faulting and sedimentation in northern San Luis Valley, Colorado: Geol. Soc. Amer. Bull. 90, pt. 2, p. 135-153.
- James, H. L. (ed.), 1971, Guidebook of the San Luis Basin, Colorado: New Mexico Geological Society Guidebook, 22nd Field Conference, 325 p.
- Johnson, B. R., Lindsey, D. A., Ellis, C. E., Hannigan, B. J. and Thompson, J. R., 1984, Mineral resource potential map of the Sangre de Cristo Wilderness study area, south-central Colorado: U.S. Geological Survey Map MF-1635-A, scale 1:62,500, 13 p. text.
- Johnson, B. R., Lindsey, D. A., Bruce, R. M. and Soulliere, S. J., 1987, Reconnaissance geologic map of the Sangre de Cristo Wilderness study area, south-central Colorado: U.S. Geological Survey Map MF-1635B, scale 1:62,500.
- Johnson, B. R., Bruce, R. M., and Lindsey, D. A., 1989, Reconnaissance geologic map of the Medano Pass quadrangle and part of the Liberty quadrangle, Alamosa, Huerfano, and Saguache Counties, Colorado: U.S. Geological Survey Map MF-2089, scale 1:24,000.
- Johnson, B. R. and Bruce, R. M., 1991, Reconnaissance geologic map of parts of the Twin Peaks and Blanca Peak quadrangle, Alamosa, Costilla, and Huerfano Counties, Colorado: U.S. Geological Survey Map MF-2169, scale 1:24,000.
- Johnson, R. B., 1967, The Great Sand Dunes of southern Colorado: U.S. Geological Survey Professional Paper 575-C, p. C177-C183.
- Karig, D. E., 1964, Structural analysis of the Sangre de Cristo Range, Venable Peak to Crestone Peak, Custer and Saguache County, Colorado: M.S. Thesis, Colorado School of Mines, Golden.
- Keller, G. R. and Adams, H. E., 1976, A reconnaissance micro-earthquake survey of the San Luis Valley, southern Colorado: B Seismologic Society of America 66, p. 345-347.
- Kirkham, R. M. and Rogers, W. P., 1981, Earthquake potential in Colorado: Colorado Geological Survey Bulletin 43, 171 p.
- Kluth, C. F., 1986, Plate tectonics of the Ancestral Rocky Mountains, *in* Peterson, J. A. (ed.), Paleotectonics and sediments: American Association of Petroleum Geologists Memoir 41, pp. 353-369.
- Knepper, D. H., Jr. and Marrs, R. W., 1971, Geologic development of the Bonanza-San Luis Valley-Sangre de Cristo Range area, south-central Colorado, *in* James, H. L. (ed.), Guidebook of the San Luis Basin, Colorado: New Mexico Geological Society Guidebook, 22nd Field Conference, 325 p.
- Knepper, D. H. J., 1974, Tectonic analysis of the Rio Grande rift zone, central Colorado: Ph.D. Dissertation, Colorado School of Mines, Golden.
- Koch, R. W., 1963, Geology of the Venable Peak area, Sangre de Cristo Mountains, Colorado: M.S. Thesis, Colorado School of Mines, Golden.
- Kouther, M. J. M., 1968, Geology and minerals of northwest part of Bonanza quadrangle, Chaffee and Saguache Counties, Colorado: M.S. Thesis 1237, Colorado School of Mines, 93 p., Golden.
- Lindsey, D. A. and Schaefer, R. A., 1984, Principal reference section for Sangre de Cristo Formation (Pennsylvanian and Permian), northern Sangre de Cristo Range, Saguache County, Colorado: U.S. Geological Survey Map MF-1622A.
- Lindsey, D. A., Scott, G. R., Soulliere, S. J., and De Angelis, B. L., 1984, Geologic map of the Horn Peak quadrangle, Custer and Saguache Counties, Colorado: U.S. Geological Survey, Map MF-1623, scale 1:24,000.

- Lindsey, D. A., Clark, R. F., and Soulliere, S. J., 1985, Reference section for the Mintum Formation (Middle Pennsylvanian), northern Sangre de Cristo Range, Custer County, Colorado: U.S. Geological Survey Map M-1622-C.
- Lindsey, D. A., Soulliere, S. J. and Hafner, K., 1985, Geologic map of Electric Peak and southwestern part of Beckwith Mountain quadrangles, Custer and Saguache Counties, Colorado: U.S. Geological Survey Map MF-1786, scale 1:24:000.
- Lindsey, D. A., Soulliere, S. J., Hafner, K. and Flores, R. J., 1985, Geologic map of Rito Alto Peak and northeast part of Mirage quadrangle, Custer and Saguache Counties, Colorado: U.S. Geological Survey Map MF-1787.
- Lindsey, D. A., Clark, R. F., and Soulliere, S. J., 1986, Minturn and Sangre de Cristo Formations of southern Colorado - A prograding fan delta and alluvial fan sequence shed from the Ancestral Rocky Mountains, *in* Peterson, J. A. (ed.), Paleotectonics and sedimentation: American Association of Petroleum Geologists Memoir 41, p. 541-561.
- Lindsey, D. A., Andriessen, P. A. M., and Wardlaw, B. R., 1986, Heating, cooling and uplift during Tertiary time, northern Sangre de Cristo Range, Colorado: Geological Society of America Bulletin 97, p. 1133-1143.
- Lindsey, D. A., Johnson, B. R., Soulliere, S. J., Bruce, R. M. and Hafner, K., 1986, Geologic map of the Beck Mountain, Crestone Peak, and Crestone quadrangles, Custer, Huerfano and Saguache Counties, Colorado: U.S. Geological Survey Map MF-1878, scale 1:24,000
- Lindsey, D. A. and Soulliere, S. J., 1987, Geologic map and sections of the Valley View Hot Springs quadrangle, Custer and Saguache Counties, Colorado: U.S. Geological Survey, Map MF-1942, scale 1:24,000.
- Lipman, P.W., 1976, Geologic map of the Del Norte area, eastern San Juan Mountains, Colorado: U.S. Geol. Surv. Map I-952, scale 1:48,000.
- Lipman, P. W., Steven, T. A. and Mehnert, H. H., 1970, Volcanic history of the San Juan Mountains, Colorado, as indicated by Potassium-argon dating: Geological Society of America Bulletin 81, p. 2329-2352.
- Lipman, P. W. and Mehnert, H. H., 1975, Late cenozoic basaltic volcanism and development of the Rio Grande depression in the southern Rocky Mountains, *in* Curtis, B. F. (ed.), Cenozoic history of the southern Rocky Mountains: Geological Society of America Memoir 144, p. 119-154.
- Litsey, L. R., 1958, Stratigraphy and structure of the northern Sangre de Cristo Mountains, Colorado: Geological Society of America Bulletin 69, p. 1143-1178.
- Mayhew, J. D., 1969, Geology of eastern part of Bonanza volcanic field, Saguache County, Colorado: M.S. Thesis 1226, Colorado School of Mines, 94 p., Golden.
- McCalpin, J. P., unpub., Assessment of faulting at the proposed new landfill site for Rio Grande County, Colorado: report prepared by GEO-HAZ Consulting for the Rio Grande County Commissioners, Nov. 28, 1992, 13 p.
- McCalpin, J. P., 1983, Quaternary geology and of the northern Sangre de Cristo Mountains, south-central Colorado: Colorado School of Mines Quarterly 77(3), 97 p, Golden.
- Munger, R. D., 1959, Geology of the Spread Eagle Peak area, Sangre de Cristo Mountains, Saguache and Custer Counties, Colorado: M.S. Thesis, University of Colorado.
- Nolting, R. M, III, 1970, Pennsylvanian-Permian stratigraphy and structure geology of the Orient-Cotton Creek area, Sangre de Cristo Mountains, Colorado: M.S. Thesis 1311, Colorado School of Mines, 102 p., Golden.
- Patton, H. B., 1915, Geology and ore deposits of the Bonanza District, Saguache County, Colorado: U.S. Geological Survey Bulletin 9, 136 p.
- Perry, H., 1971, Geology of the northern part of the Bonanza volcanic field, Saguache County, Colorado: M.S. Thesis, Colorado School of Mines, 362 p., Golden.
- Peterson, R. E., 1979, Tectonic geomorphology of the northern Sangre de Cristo Mountains near Villa Grove, Colorado: M.S. Thesis, University of Arizona, Tucson.
- Reynolds, T. B., 1986, Geology and regional significance of Blanca Peak area, Huerfano County, Colorado: M.S. Thesis, Wichita State University, Wichita, Kansas, 165 p.
- Schumm, S.A., Bean, D.W. and Harvey, M.D., 1982, Bed-form-dependent pulsating flow in Medano Creek, southern Colorado: Earth Surface Processes and Landforms 7: 17-28.

- Scott, G. R. and Taylor, R. B., 1975, Post-Paleocene tertiary rocks and Quaternary volcanic ash of the Wet Mountain Valley, Colorado: U.S. Geological Society Professional Paper 868, 15 p.
- Stover, C.W., Reager, B.G. and Algermissen, S.T., 1988, Seismicity map of the State of Colorado: U.S. Geol. Surv. Map MF-2036, scale 1:1,000,000.
- Taylor, R. B., 1975, Neogene tectonism in south-central Colorado, *in* Curtis, B. F. (ed.), Cenozoic history of the southern Rocky Mountains: Geological Society of America Memoir 144, pp. 211-226.
- Toulmin, P., III, 1953, Petrography and petrology of Rito Alto Stock, Custer and Saguache County, Colorado: M.S. Thesis, University of Colorado.
- Tweto, O., 1975, Laramide (Late Cretaceous-early Tertiary) orogeny in the southern Rocky Mountains, *in* Curtis, B. F. (ed.), Cenozoic history of the southern Rocky Mountains: Geological Society of America Memoir 144, p. 1-44.
- Tweto, O., 1979, The Rio Grande rift system in Colorado, *in* Rieder, R. E. (ed.), Rio Grande rift: tectonics and magmatism: American Geophysical Union, Washington, D.C., p. 33-56.
- Upson, J. E., 1939, Physiographic subdivision of San Luis Valley, southern Colorado: *Journal of Geology* 47, p. 721-736.
- Upson, J. E., 1941, The Vallejo Formation: new early Tertiary red-beds in southern Colorado: *American Journal of Science* 239, p. 577-589.
- Volckmann, R. R., 1965, Geology of the Crestone Peak area, Sangre de Cristo range, Colorado: Ph.D. Dissertation, University of Michigan, Ann Arbor.
- Williams, M. D., 1992, Characteristics of unconfined alluvial aquifer system of northern San Luis Valley, Colorado, using GIS data management and visualization techniques: M.S. Thesis, Colorado School of Mines, 121 p., Golden.
- Wychgram, D. C., 1972, Geology of the Hayden Pass-Orient Mine area, northern Sangre de Cristo Mountains, Colorado: a geologic remote sensing investigation: M.S. Thesis, Colorado School of Mines, Golden.



## *Tertiary stratigraphy and tectonic development of the Alamosa basin (northern San Luis Basin), Rio Grande rift, south-central Colorado*

**Brian S. Brister\***

*New Mexico Institute of Mining and Technology, Socorro, New Mexico 87801*

**Robbie R. Gries\***

*Independent Geologist, Denver, Colorado 80203*

### ABSTRACT

Analysis of borehole and reflection seismic data from the Alamosa basin (northern San Luis Basin, Rio Grande rift) reveals tectonic development in response to three Tertiary events, each with an associated package of rocks distinguished by mineralogy and petrology. Eocene redbeds of the Blanco Basin Formation (0 to 696 m thick) are micaceous, sandy mudstone and coarse arkosic sandstone units containing lithic pebbles derived from granitic basement rock. They were deposited in a late Laramide basin formed during wrench-fault-related segmentation of the early Laramide San Luis–Brazos uplift. The western half of the younger, rift-related Alamosa basin is superposed over this late Laramide basin. Initiation of Oligocene volcanism is marked by andesitic lava flows and volcanoclastic rocks of the Conejos Formation (0 to 2,300 m thick), also limited in extent to the western half of the Alamosa basin. Ash-flow tuffs (380 to 580 m thick) correlative to 29 to 27 Ma tuffs of the San Juan volcanic field cap the Conejos Formation in the western half of the basin and rest directly on denuded Precambrian basement in the eastern half of the basin. These tuffs exist in deep wells across the Alamosa basin and together represent a basinwide time marker. Extension related to the Rio Grande rift resulted in eastward-tilting of the entire basin area following emplacement of the ash-flow tuffs. Filling the resulting half graben is the upper Oligocene–middle Pleistocene Santa Fe Group (as much as 5.6 km thick) composed of variegated mudstones and coarse lithic sandstones and conglomerates. Lithic fragments in the Santa Fe Group represent two sources: variable-composition volcanic rocks from the San Juan volcanic field to the west (majority) and plutonic-metamorphic-sedimentary, basement-derived rocks from the Sangre de Cristo Range to the east (minority). An angular unconformity within the Santa Fe Group documents strong early tilting due to movement on the Sangre de Cristo fault zone during an early phase of rifting (late Oligocene–early Miocene). The rift-related geometry of the crust beneath the Alamosa basin is that of two east-tilted crustal blocks creating two second-order half grabens within the basin.

---

\*Present addresses: Brister, Burnett Oil Company, Inc., 801 Cherry Street, Suite 1500, Fort Worth, Texas 76102; Gries, Pease Oil and Gas Company, 633 17th Street, Suite 1500, Denver, Colorado 80202.

## INTRODUCTION

The Alamosa basin is a subbasin of the San Luis Basin of south-central Colorado and north-central New Mexico. The San Luis Basin is one of a series of similar features in the Rio Grande rift (Fig. 1), a north-trending intracontinental rift that extends from north of Leadville, Colorado, to El Paso, Texas, and beyond (Chapin, 1971). The San Luis Basin is more than 200 km long from north to south. Its northern physiographic limit is at Poncha Pass, Colorado (Upson, 1939), and its southern limit is near the Embudo constriction in New Mexico (Kelley, 1956). The San Luis Basin is bordered by the San Juan and Tusas Mountains on the west and the Sangre de Cristo Range on the east. At the latitude of Alamosa, Colorado, it is about 70 km across. This paper examines a 5,520 km<sup>2</sup> area in the San Luis Basin, north of the San Luis Hills, termed the "Alamosa basin" by Burroughs (1981). Its stratigraphy, struc-

ture, and tectonic history are interpreted from subsurface data, including borehole samples and geophysical surveys.

The Alamosa basin has had a complex history. The region has been recurrently uplifted and down dropped during several tectonic events (Sales, 1983). As a Rio Grande rift basin, the Alamosa basin today takes the form of an asymmetric, first-order half graben with stratigraphic units tilted eastward from their pre-rift orientations (Fig. 2). This half graben is bounded along the Sangre de Cristo Range by the Sangre de Cristo fault zone (Personius and Machette, 1984, p. 87). The basin is divided into a western ("Monte Vista") graben and eastern ("Baca") graben by a basement high termed the "Alamosa horst" (Burroughs, 1981). Both grabens are second-order half grabens, but the Baca graben was the site of the greatest degree of tilting and thickest sedimentary infilling during rifting due to its proximity to the Sangre de Cristo fault zone.

The purpose of this paper is to present an interpretation of

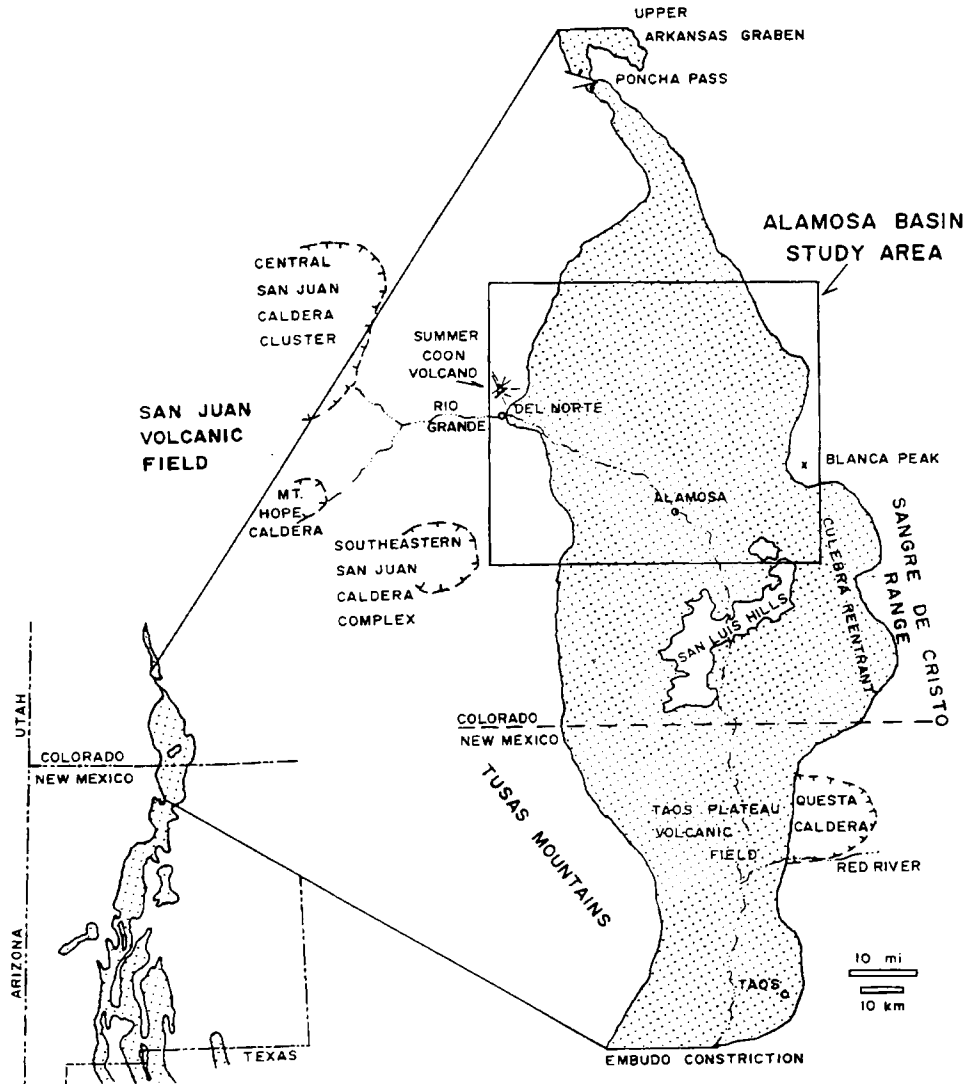

Figure 1. Location map showing Alamosa basin study area, San Luis Basin, Rio Grande rift, and geographic features discussed in text. Stippled pattern denotes rift-basin fill.

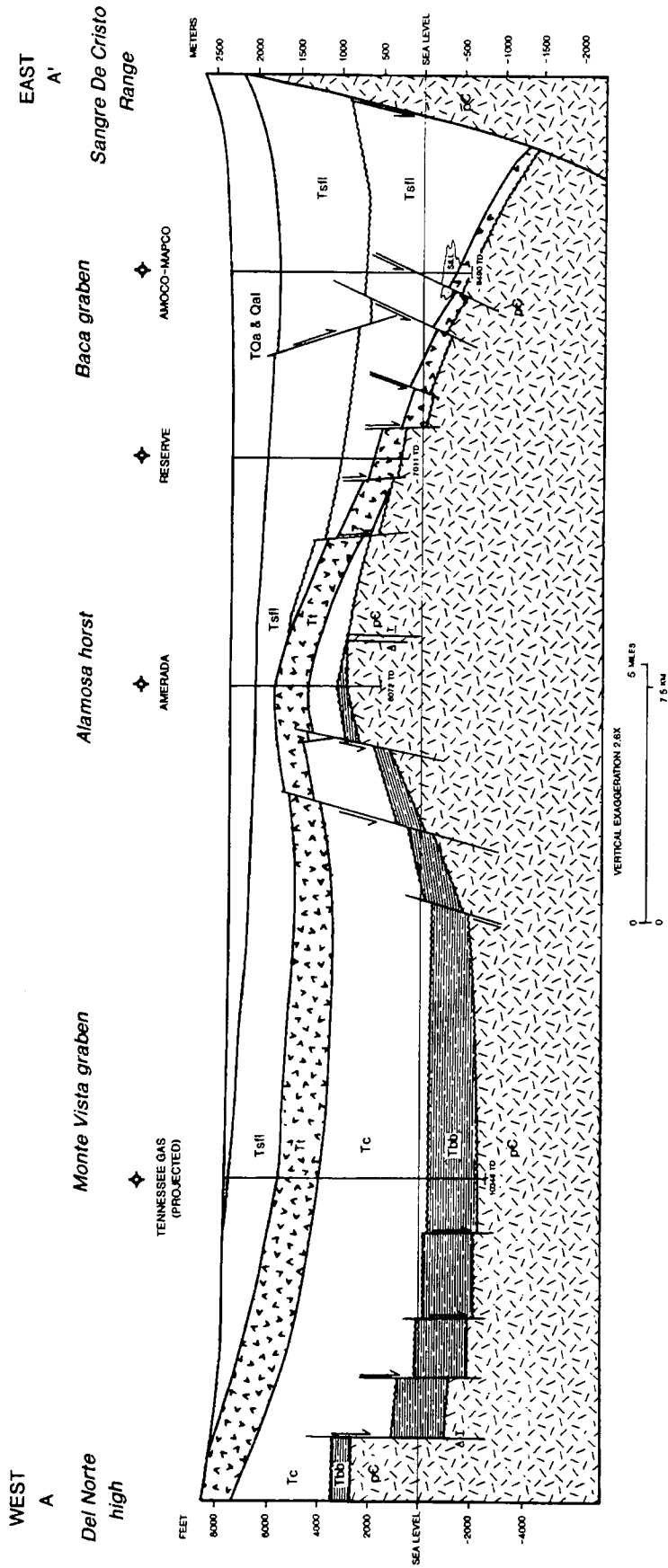

Figure 2. Interpretive cross section A-A' across the San Luis Basin; location of section indicated in Figure 3. Symbols: TQa and Qal, Alamosa Formation (Plio-Pleistocene) and Quaternary alluvium; Tc, lower Santa Fe Group (Mio-Pliocene); Tt, ash-flow tuffs of San Juan volcanic field (Oligocene); Tc, Conejos Formation and equivalents (Oligocene); Tbb, Blanco Basin Formation (Eocene); pC, granite-gneiss basement (Precambrian); TD, total depth. Figure modified from Gries and Brister (1989).

the tectonic development of the Alamosa basin based on new insight into the stratigraphy of the basin fill. The physical characteristics of the basin stratigraphy, determined from petrologic analysis of subsurface samples, define lithostratigraphic units that can be correlated using reflection seismic lines. Combining new subsurface stratigraphic and structural information has led to a new interpretation of the timing of episodes of basin development.

## PREVIOUS WORK

The classic references on the location and physiographic setting of the basin are Siebenthal (1910b) and Upson (1939). Overviews that discuss the relation of the San Luis Basin to the Rio Grande rift are Chapin (1971, 1979, 1988), Cordell (1978), Hawley (1978), Keller et al. (1984), and Tweto (1979). Ingersoll et al. (1990) present a detailed study of the sedimentation and paleotectonics of the southern San Luis Basin based on outcrop-derived data and regional correlation. Notable geophysical investigations of the northern San Luis Basin are Cordell (1978), Gries (1985a), Keller et al. (1984), and Stoughton (1977).

Huntley (1979) was the first to publish a correlation of stratigraphic units between boreholes suggesting that the basin fill was entirely of Tertiary age. Burroughs (1981) noted that some of the more wide ranging volcanic units of the region could be correlated in borehole geophysical logs.

Reflection seismic lines published by Gries (1985a) were of high quality, but a lack of detailed petrologic data limited interpretation of the various features visible on the lines. Attempts by Gries to resolve this problem utilizing radiometric and palynological dating techniques were unsuccessful. This paper applies the results of a petrologic study of borehole samples to reinterpret seismic data in the basin. Preliminary results were discussed in Gries and Brister (1989).

## STRATIGRAPHY

The sequence of lithostratigraphic units in the Alamosa basin varies greatly depending upon location. Regional tectonic events had different effects on the western and eastern halves of the basin, therefore the two halves have significantly different stratigraphic sections. The stratigraphy is illustrated by a west-to-east cross section (Fig. 2, location shown in Fig. 3).

### *Precambrian basement (pC)*

The stratigraphically lowest unit is Precambrian basement. In general, the basement rocks are granitic in composition but have a gneissic texture and have high electrical resistivity (100 to 2,000 ohmms) and densities typical of granitic rocks (greater than 2.6 gm/cc). Cuttings are commonly stained orange by hematite, especially along grain boundaries.

This may be a result of weathering when the basement was exposed subaerially during several Phanerozoic orogenic events as will be discussed below.

Basement rocks contain quartz, orthoclase, microcline, perthite, plagioclase, muscovite, biotite, and amphibole. Alignment of micas is common in most samples. Most quartz grains are strained, monocrystalline types that reflect a probable metamorphic origin. Some quartz grains are coarsely polycrystalline with nonsutured boundaries. Although these grains would usually be expected to come from metaquartzites, they may also be found in finer-grained granites and schists (Folk, 1974).

Many metamorphic rock types have been described from exposures in the nearby Sangre de Cristo Range (Johnson, 1969), including granites, gneisses of various compositions, amphibolites, and metasediments. Such variation probably also exists beneath the Alamosa basin, but has not been found by sparse drilling. The top of the Precambrian basement is an unconformable surface of erosion, upon which Tertiary units were deposited.

### *Blanco Basin Formation (Tbb)*

The Blanco Basin Formation (Eocene) consists of nonvolcanic, alluvial redbeds unconformably overlying the Precambrian basement in wells in the western half of the Alamosa basin (Monte Vista graben). Total thickness varies across the basin from 0 to 696 m. The Blanco Basin Formation is composed of sandy, micaceous mudstone and coarse arkosic sandstone and conglomerate.

The mineral composition of the coarser sedimentary rocks is identical to that of the Precambrian basement and indicates that basement rocks were their primary source. Sandstones in some wells also contain a small percentage of sedimentary rock fragments of Paleozoic and/or Mesozoic provenance. Rarely, fine- to medium-grained, frosted, rounded quartz grains exist in the samples, perhaps eroded from Jurassic eolian sandstone formations such as the Junction Creek Formation. In Figure 4, the composition of the Blanco Basin Formation is compared with younger Tertiary sandstones in the basin.

Those units sampled that were interpreted as "sands" from geophysical logs are arkosic, coarse, pebbly sandstones and conglomerate beds containing granitic pebbles. The log characteristics of these bodies are variable, but individual sand bodies tend to be "cylinder shapes" (terminology of Rider, 1986) with lesser bell and funnel shapes. Contacts against surrounding mudstone beds range from abrupt to gradational.

Blanco Basin mudstones are generally reddish brown (Hue 10R, saturation 4 to 6, value 3 to 4) but may vary to red, green, gray, maroon, and purple. A single cutting chip may display mottling of two or more of these colors suggesting that coloration may be dependent upon diagenesis. The mudstones have not yielded fossils or pollen, and thus the exact age of the formation is unknown.

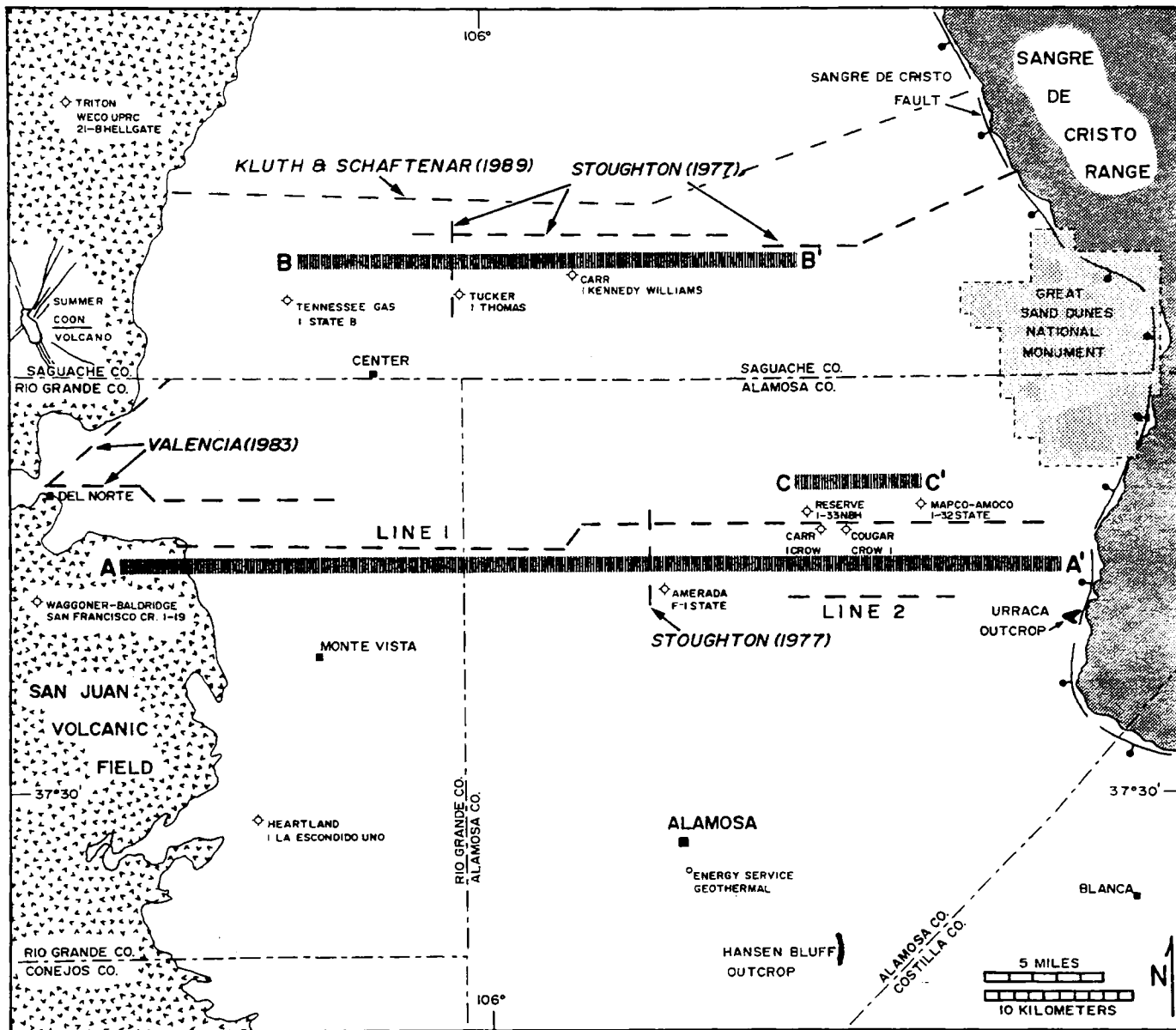

Figure 3. Map of the Alamosa basin study area showing oil and gas drilling, seismic lines illustrated or discussed in this paper, and cross sections A-A', B-B', and C-C'.

The formation here termed Blanco Basin Formation in the western part of the Alamosa basin has been considered to be Eocene in age by other workers based on its color, degree of consolidation and cementation, and depositional facies characteristics. Tweto (1979) correlated it with the "Eocene Echo Park Alluvium" (Echo Park Formation of Epis and Chapin, 1974). Covarrubias (1988) termed the formation "Eocene red beds." Baltz (1965) believed the formation to be similar to the Blanco Basin Formation of Larsen and Cross (1956) although he did not specifically assign that name.

Huntley (1979) and Burroughs (1981) applied the name Vallejo Formation due to the apparent similarity of these beds

to the "fluvial red-beds" described by Upson (1941) in the Culebra reentrant southeast of the study area. However, we believe that the age of the Vallejo Formation at its type locality is Miocene or younger based on regional correlation to units with similar petrologic characteristics. Regardless of the name chosen, both Huntley and Burroughs believed their "Vallejo" beds in the subsurface to be pre-Oligocene.

The best evidence for the identity of the redbeds in the Monte Vista graben comes from recent drilling in the San Juan sag (Gries, 1985b) west of the Alamosa basin. The San Juan sag is separated from the Alamosa basin by the Laramide wrench-fault-related Del Norte high (Gries, 1989; Brister,

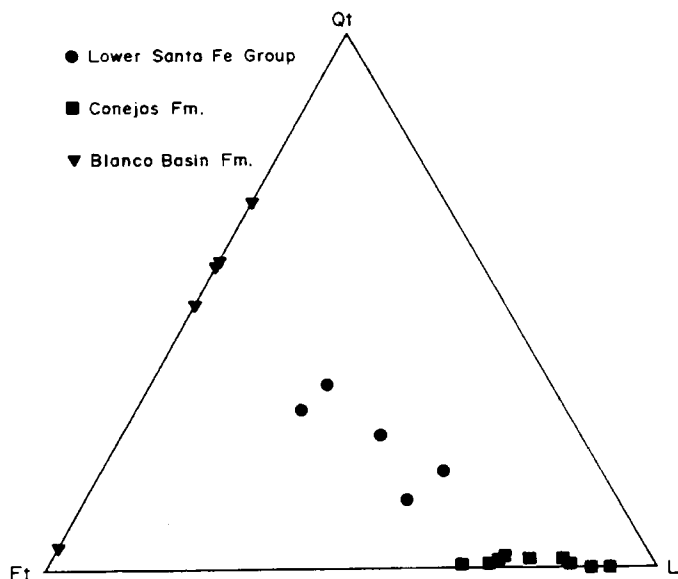

Figure 4. Ternary diagram of sandstone compositions from subsurface units in the Alamosa basin. Qt, total quartz, including polycrystalline grains + quartzite + chert; Ft, total feldspar; L, sedimentary + volcanic + metamorphic lithic grains. Each symbol represents at least 500 points counted in a single sample. See Brister (1990) for data tables and sample locations.

1990). The rebeds of the Monte Vista graben can be correlated in the subsurface across the Del Norte high, into the San Juan sag, and eventually to outcrops some 45 km to the west along the southwestern flank of the San Juan Mountains where they have been assigned the name Blanco Basin Formation (Cross and Larsen, 1935). Their age in the San Juan sag is generally believed to be Eocene because, like the Blanco Basin Formation to the southwest, they are bracketed by unconformable contacts with the Paleocene Animas Formation below and the Oligocene Conejos Formation above. The petrologic characteristics of the rebeds encountered in the Monte Vista graben are similar to those of the Blanco Basin Formation in general and are consistent with the petrologic variability between, and within, Blanco Basin outcrops (Brister, 1992).

The Blanco Basin Formation has been drilled in six of the wells shown in Figure 3. The thickest sections penetrated are 696 m in the Triton/Weco/UPRC 21-B Hellgate well, and 643 m in the Tennessee Gas Transmission 1-State B well. A possible explanation for the great thickness in these wells compared to typical thickness of the formation of about 175 m is that they exist adjacent to a major Laramide basin-bounding fault zone separating the Laramide precursor basin of the Monte Vista graben from the Del Norte high.

Wells drilled west of this fault zone on the Del Norte high contain thinner Blanco Basin Formation. They are the Waggoner-Baldrige San Francisco Creek 1-19 well with 159 m, and the Heartland #1 La Escondido Uno well with only 49

m. The Amerada F-1 State well in the vicinity of the Alamosa horst drilled 115 m, which is the easternmost-known Blanco Basin equivalent rocks. The Tucker #1 Thomas well bottomed in the Blanco Basin Formation, drilling only 34 m as estimated from a description by Powell (1958).

### Conejos Formation (Tc)

The Conejos Formation is a series of intermediate-composition volcanoclastic rocks and lava flows (35 to 30 Ma) that were derived from volcanoes active in the San Juan volcanic field from 35 to 30 Ma (Lipman et al., 1970). The Conejos volcanic rocks are high-K, subalkalic, and commonly range from andesite to quartz latite (silicic dacite) in composition (Lipman, 1989). Lithologic units in the formation vary depending upon distance from vents and/or periodic extrusive activity. These include volcanic breccias of both "hot" and "cold" origin and emplacement (these range from mono- to heterolithologic and include, but are not limited to, debris-avalanche and debris-flow deposits), lava flows, autobrecciated flows, stream-laid conglomerate and sandstone, and organic-rich lacustrine claystone. Ash-flow tuffs are rare (Lipman, 1975), but some of the volcanoclastic deposits are tuffaceous, containing relict glass shards and rare reworked welded tuff fragments. The above description applies well to the package of rocks marked Conejos Formation on Figure 2. As seen in Figure 4, Conejos sandstones from wells in the Alamosa basin are lithic rich; this lithic component is generally 100% intermediate-composition volcanic rock fragments.

Only one Conejos vent has been documented in the study area: that of the Summer Coon volcano (Lipman, 1968) located on the western edge of the basin north of the town of Del Norte. Other sources for Conejos deposits in the Alamosa basin are located to the southwest, where vents have been documented in the Platoro, Colorado, area (Lipman, 1975), and possibly the south, from vents in the San Luis Hills (Burroughs, 1971, 1972, 1981; Thompson and Machette, 1989). The vents responsible for the Bonanza Tuff and related andesitic breccias (Steven and Lipman, 1976) comprise a possible northern source for Conejos-equivalent volcanoclastic detritus.

The Conejos units in the Alamosa basin were probably deposited on the distal fringes of vent complexes. In general, those wells along the western side of the Alamosa basin have a high percentage of flows and coarse volcanoclastic rocks, but this percentage decreases eastward in favor of finer-grained deposits. The Conejos Formation also decreases in thickness eastward to a zero edge over the central part of the basin. The thickest section drilled in the study area is 2,300 m in the Triton/WECO/UPRC 21-B Hellgate well, which is situated on the northern flank of the Summer Coon volcano. Most other wells in the western half of the Alamosa basin have penetrated 1.3 to 1.5 km of the Conejos Formation. The easternmost section of the Conejos Formation is in the Amerada F-1 State well, which had only 400 m.

*sh-flow tuffs (Tt)*

A package of interbedded ash-flow tuffs and tuffaceouslastic rocks marked Tt on Figure 2 overlies the Conejos formation. This package is important because it: (1) exists throughout the basin; (2) separates Rio Grande rift-related deposits above it from pre-rift formations below it; (3) has been radiometrically dated (in the San Juan Mountains) and has been demonstrated to represent a short interval of time; and (4) shows distinctive (although nonunique) identifiable characteristics on borehole geophysical logs and reflection seismic lines. These characteristics used in conjunction with petrologic examination have allowed the utilization of the package as a time marker in the stratigraphic sequence (Brister, 1990).

The ash-flow tuffs in this sequence are part of a series of volcanic rocks, 26 to 30 m.y. old (Steven and Lipman, 1976), which originated in the eastern San Juan volcanic field. Only the most voluminous flows made their way to the Alamosa basin area. The key to their identity are outcrops in the eastern foothills of the San Juan Mountains where the tuffs dip at angles of less than 10° into the basin. The 29.5 to 28.4 Ma Treasure Mountain Tuff (Lipman and Steven, 1970; Lipman, 1989), erupted from the southeastern San Juan caldera com-

plex, and the 28.4-Ma Masonic Park Tuff (Lipman et al., 1970; Steven et al., 1974; Lipman, 1989), erupted from the Mount Hope caldera, contributed the majority of the material to the tuff package in the southern part of the Alamosa basin. Likewise, the 27.75-Ma Fish Canyon and 27.35-Ma Carpenter Ridge tuffs (Olson et al., 1968; Lipman, 1989) from the central caldera cluster dominate the tuff sequence to the north.

Figure 5 is a cross section constructed from borehole geophysical logs drawn such that the datum is the top of the tuff package. In each well shown, there are no lava flows or welded tuffs above this horizon. The figure illustrates which units have been positively identified as ash-flow tuffs using criteria outlined above. Tentative correlations have been drawn between the logs based primarily on log response rather than petrographic criteria. Resistivity curve profiles for the tuff units may mimic welding profiles. It is assumed that any given ash-flow tuff has similar log response between two wells over a relatively short distance, thus pattern recognition of log curves was helpful in correlation.

It can be observed that the westernmost (which are also the northernmost) wells generally have thin Masonic Park Tuff and Treasure Mountain Tuff compared to those wells farther south and east. These wells are near the distal edge of the

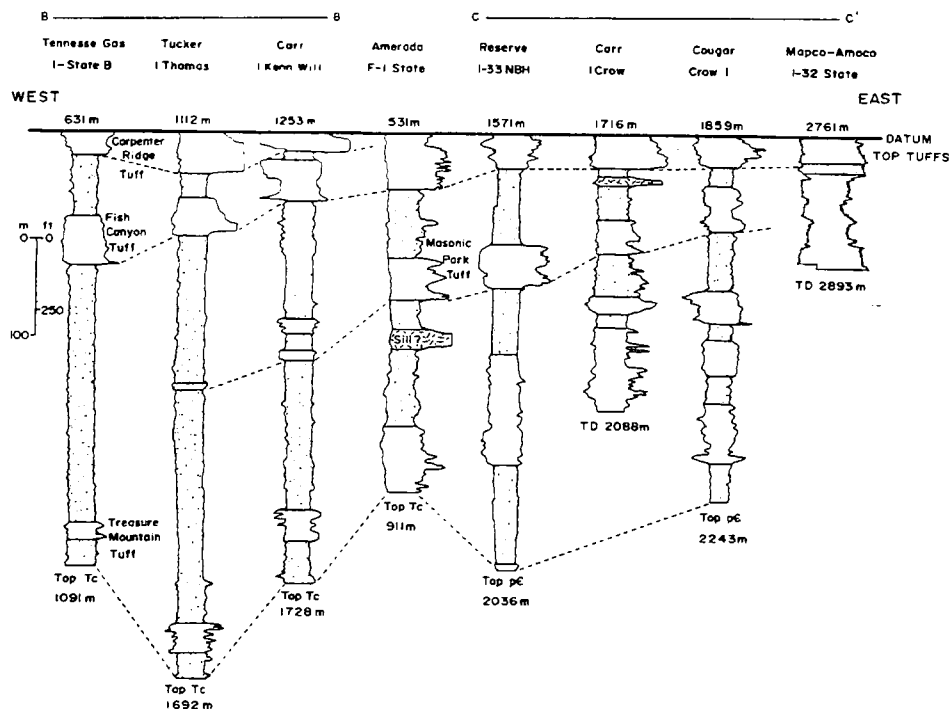

Figure 5. Well-log comparison of Oligocene ash-flow-tuff package in Alamosa basin illustrating tentative correlations; drillholes indicated are on Figure 3. Log curves are spontaneous potential (left) and resistivity (right); exception is Mapco-Amoco I-32 State well (gamma ray on left; density on right). Datum is top of the ash-flow tuffs/base of Santa Fe Group (depth of datum listed above heavy line). Unit underlying tuffs and depth of contact indicated at bottom. A similar package of tuffs to that in the Amerada F-1 State well is present in the Energy Service #1 Alamosa Geothermal well but electric logs are not available. Stippled areas are unwelded tuffs and tuffaceous sediments; unstippled areas are welded units.

Masonic Park and Treasure Mountain tuffs that were erupted from the Mount Hope and southeastern caldera complex (see Fig. 1). The nearby Summer Coon volcano of Conejos age was probably topographically high enough to stand in the way of the ash flows, creating a shadow. For the same reasons, wells to the southeast generally lack a recognizable section of Carpenter Ridge Tuff.

Prior to this study, it was believed that the upper Oligocene San Juan tuffs pinch out in the Monte Vista graben (Tweto, 1979) or over the Alamosa horst (Burroughs, 1981). The explanation for such pinching out was that the Alamosa horst prevented tuffs from reaching the eastern half of the basin. Figure 5 shows that if a topographically high area existed, it provided no impediment to ash flows moving across it. In fact, it is likely that the ash flows may have reached eastward beyond the present-day Sangre de Cristo Range (Burroughs, 1981; Scott, 1975). Also, there is no apparent thinning of ash-flow tuffs in wells (Amerada F-1 State, and Energy Service Geothermal) over the horst area. There is, however, overall thinning of the intertuff clastic deposits eastward in the wells, suggesting increasing distance from the major source of these sediments and/or a positive paleotopographic gradient to the east. The effect of this sedimentation was to blanket and subdue existing topography. The top of the tuffs in the subsurface is an east-dipping surface today, due to postemplacement tilting.

### *Santa Fe Group (Tsfl and Ta)*

The Santa Fe Group includes all pre-middle Pleistocene sediments above the upper Oligocene tuffs. It can be roughly divided into two units, upper and lower Santa Fe Group, based upon lithologic criteria. The lower Santa Fe Group is ubiquitous in the subsurface of the basin and represents large-scale sedimentary response to half-graben development from late Oligocene to Pliocene. The upper Santa Fe Group, named the Alamosa Formation, represents lacustrine and fluvial sedimentation ranging in age from Pliocene to middle Pleistocene. Cross section B'-C' (Fig. 6), summarized from well data, illustrates the stratigraphy of the Santa Fe Group in the Alamosa basin.

**Lower Santa Fe Group.** The lower Santa Fe Group in the Alamosa basin has been called the Santa Fe Formation (Siebenthal, 1910b; Powell, 1958). However, Spiegel and Baldwin (1963) began the modern usage of "Santa Fe" as a group term "that includes all the synrift basin fill, both volcanic and sedimentary, ranging in age from late Oligocene to Quaternary, but excluding deposits that postdate entrenchment of the Rio Grande in middle Pleistocene time" (Chapin, 1988, p. 169). Burroughs (1981) has suggested that the lower Santa Fe Group may be divided into formations based on composition and provenance. No attempt has been made in this study to subdivide the lower Santa Fe Group because of lack of sufficient subsurface data. The age of lower Santa Fe Group sediments in the Alamosa basin is poorly constrained, but ranges

from about 26 Ma to about 4.5 Ma. The older age is approximately the end of ash-flow volcanism in the eastern San Juan Mountains (Steven et al., 1967; Lipman, 1989). The younger age marks the beginning of tholeiitic basalt volcanism and construction of the Taos Plateau volcanic field that blocked surface drainage in the southern San Luis Basin (Lipman and Mehnert, 1979) and was responsible for the widespread fluvio-lacustrine system of the Alamosa Formation.

Grain size and composition of the lower Santa Fe Group vary depending primarily upon proximity to sources and character of dispersal systems. Well samples from the study area are of claystone, sandstone, and conglomerate. The claystone and sandy mudstone in the lower Santa Fe Group are compact but soft, nonfissile, and micaceous. They deepen in color with increasing depth in the basin, but are everywhere variegated. Typical colors include tan, pink, buff, orange, brick red, light olive, and light gray to black. Most of these colors are indicative of an oxidizing environment of deposition. A coal seam was penetrated in fine-grained units in the Mapco-Amoco #1-32 State well at 1,774 m depth. There are no known bedded evaporites in the sequence, but scattered selenite crystals can be found in the cuttings.

The lowermost Santa Fe beds have been reported to be early Tertiary in age on the basis of pollen analyses (Huntley, 1976; Gries, 1985a). However, the pollen assemblages are sparse, not indicative of any specific Tertiary age, and contain a few specimens of probable Eocene age that may have been reworked. Lithologic and stratigraphic criteria discussed above provide strong evidence that these sediments postdate upper Oligocene ash-flow tuff volcanism. A rhyolite sill(?) in the Mapco-Amoco 1-32 State well at the base of the Santa Fe Group but above the Oligocene ash-flow tuff package has yielded a whole-rock K-Ar age of 22.2 Ma (R. Gries, unpublished data).

Some generalized observations of Santa Fe Group sandstones from the basin indicate that Precambrian detritus tends to increase in abundance eastward in the basin towards the Sangre de Cristo Range. All sandstones examined are lithic-rich with a majority of these fragments being of volcanic origin. Sandstone samples from the deepest part of the Baca graben are tuffaceous, but contain significant amounts of Precambrian material. On a ternary diagram (Fig. 4), these sandstones span the range in composition between samples of the Blanco Basin Formation and the Conejos Formation.

The lower Santa Fe Group sediments indicate provenance from two primary sources. The San Juan volcanic field to the west and northwest provided an influx of intermediate-composition volcanic debris including ash-flow-tuff clasts. Such deposits of late Oligocene-Pliocene age derived from the San Juan Mountains are usually referred to as the Los Pinos Formation (Butler, 1946, 1971; Manley, 1981), which Chapin (1988) has included in the Santa Fe Group. Interbedded volcanic flows are rare in the Santa Fe Group of the Alamosa basin; however, Hinsdale basalts ranging in age from 25.7 to

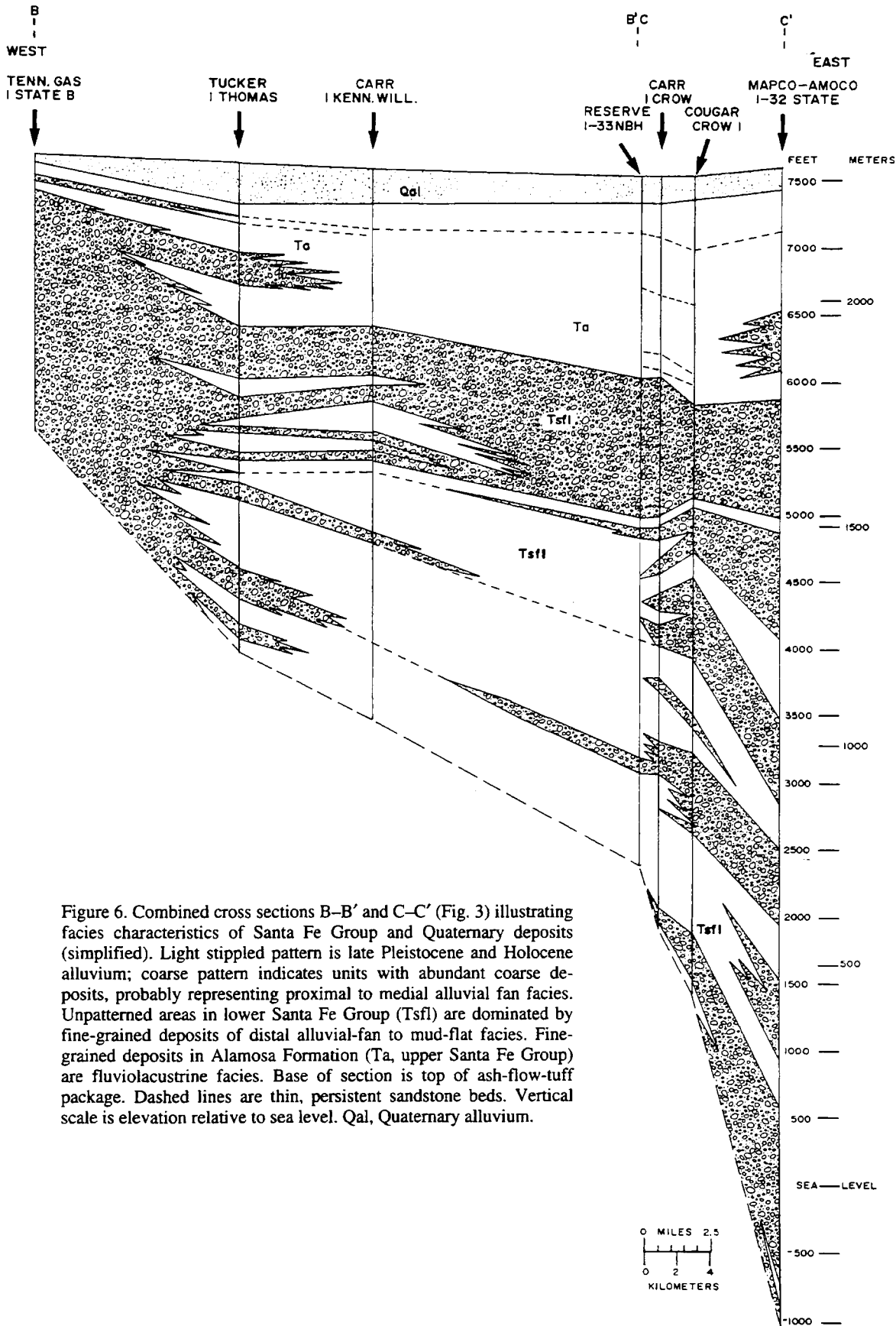

Figure 6. Combined cross sections B-B' and C-C' (Fig. 3) illustrating facies characteristics of Santa Fe Group and Quaternary deposits (simplified). Light stippled pattern is late Pleistocene and Holocene alluvium; coarse pattern indicates units with abundant coarse deposits, probably representing proximal to medial alluvial fan facies. Unpatterned areas in lower Santa Fe Group (Tsfl) are dominated by fine-grained deposits of distal alluvial-fan to mud-flat facies. Fine-grained deposits in Alamosa Formation (Ta, upper Santa Fe Group) are fluviolacustrine facies. Base of section is top of ash-flow-tuff package. Dashed lines are thin, persistent sandstone beds. Vertical scale is elevation relative to sea level. Qal, Quaternary alluvium.

26.4 Ma are interbedded with these sediments in the San Luis Hills along the southern border of the basin (Thompson and Machette, 1989). In the San Juan volcanic field the Hinsdale basalts range in age from 26 to 5 Ma (Lipman, 1975, 1969; Steven et al., 1974).

The second source of sediment was the rising Sangre de Cristo Range to the east, which was a source of detritus from Precambrian granitic and metamorphic rocks and Paleozoic limestones and clastic rocks. The Sangre de Cristo Range was at least partially covered by volcanic rocks in the late Oligocene and thus was also a source for some volcanic material.

Another possible source of sediment that has been suggested is stream flow from the Upper Arkansas graben into the Alamosa basin (Hanna and Harmon, 1989). A possible connection between the San Luis Basin and Upper Arkansas graben has been postulated due to the presence of the Mio-Pliocene Dry Union Formation (Tweto, 1961) in a narrow graben north of Poncha Pass, Colorado (Van Alstine, 1968, 1970; Knepper and Marrs, 1971, Taylor, 1975). However, neither surface mapping nor gravity surveys indicate significant Dry Union/Santa Fe deposits at Poncha Pass, but instead, demonstrate that a topographic and/or structural barrier existed in the area during the Miocene and Pliocene (Knepper, 1976).

Rare outcrops of the lower Santa Fe Group exist along the basin margins. In one location along the Sangre de Cristo fault zone, a fault slice of lower Santa Fe Group is exposed at the surface (marked "Urraca outcrop" on Fig. 3; see Gries and Vandersluis, 1989, p. 35). This deposit contains interbedded fluvial conglomerates and pebbly sandstones with beds less than a meter thick. Pebble imbrications suggest a south-southwest stream-flow direction that paralleled the Sangre de Cristo fault zone at this location. Current indicators show that the braided stream was draining parallel to the axis of the paleobasin. The rocks are well indurated and reddish brown, probably due to postdepositional cementation and oxidation. Such reddening of Santa Fe Group sediments has been reported elsewhere in the Rio Grande rift by Chapin and Lindley (1986) and has already been noted above for nearby deep-basin well samples. Composition of the pebbles in the outcrop reflect two provenances. Pebbles from the Sangre de Cristo Range include Precambrian granitic and metamorphic rocks and minor amounts of Paleozoic arkose, graywacke, siltstone, shale, limestone, and chert. Pebbles derived from the San Juan volcanic field include volcanic rocks of intermediate composition and minor flow-banded rhyolite and ash-flow tuff.

**Alamosa Formation.** The Alamosa Formation (Sieben-thal, 1910a) is a fluviolacustrine formation deposited conformably upon the uppermost beds of the lower Santa Fe Group in the Alamosa basin. The depositional environment of the Alamosa Formation was dominated by reducing conditions (Huntley, 1979) as demonstrated by the predominance of gray, black, and green claystones. Well samples contain fossil debris including ostracods, bones, peat and wood fragments, and mollusc shell fragments. Organic material taints water from

some wells and is a source of methane, the discovery of which has helped stimulate intermittent oil and gas wildcat drilling in the basin (Gries, 1985a). Toward the top of the section are persistent, poorly cemented sandstone horizons that can be correlated over broad areas of the basin. These mark the beginning of a return to drier and/or higher energy conditions in the basin. These beds have been extensively drilled in the basin because they are fresh-water bearing and artesian. They are the primary source of ground water for agriculture in the San Luis Valley.

Rogers (1984) sampled some 20 m of surface outcrop of the Alamosa Formation at Hansen's Bluff near the town of Alamosa (Fig. 3) and found the beds to be Pleistocene (0.6 to 0.9 Ma). The outcrop contains volcanic ash, various fish, bird, and mammalian bones, and fresh-water mollusc shells. The great thickness of underlying Alamosa deposits (the formation ranges up to 550 m thick) suggests that the formation is as old as Pliocene. The Hansen's Bluff deposits are overlain by Quaternary alluvium and probably predate the capture of drainage in the Alamosa basin by the Rio Grande in middle to late Pleistocene.

## INTERPRETATION OF SEISMIC DATA

### *Seismic characteristics*

Figure 7 is a synthetic seismogram from the Tennessee Gas 1-B State well, which contains all the stratigraphic units in the basin. The strongest reflections at about 0.6 seconds (two-way travel time) mark the late Oligocene welded ash-flow tuffs and the base of the Santa Fe Group. This strong reflection package was interpreted in every seismic line examined in the Alamosa basin. Because the top of the tuffs is the transition between pre-rift and syn-rift deposits, any faults that offset these reflections are a result of the rifting events. Faults that offset units below these reflections, but not the reflections themselves, are pre-rift in origin. Thus, this reflection package is important for deciphering the tectonic history of the basin.

Another strong reflection on Figure 7 exists at about 1.25 seconds. This is a local reflection associated with a 75-m-thick lava flow within the Conejos Formation. Such reflections in the Conejos are generally not far ranging. A weak double reflection exists at about 1.95 seconds and marks the top of the Precambrian basement.

An interpreted seismic line across the Alamosa basin (Fig. 8) illustrates the seismic characteristics of the lithostratigraphic units present. The top of the late Oligocene tuffs is the strong reflection that is not visibly faulted in the western half of the basin, but is faulted and tilted down to considerable depth in the Baca graben to the east. Well control helps to distinguish this reflection from internal reflections of the Santa Fe Group in the deeper parts of the Baca graben.

Below the strong tuff reflections, the Conejos and Blanco Basin Formations contain reflections that vary from strong and

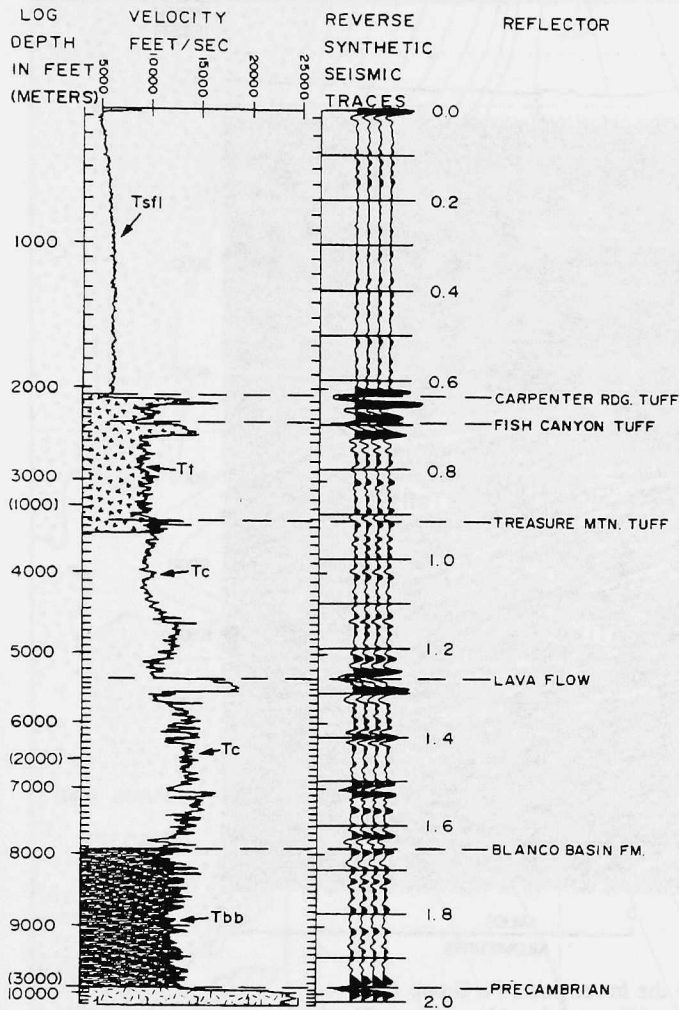

Figure 7. Synthetic seismogram from the Tennessee Gas Transmission 1 State B well in the Monte Vista graben. For other synthetic seismograms in the area, see Gries (1985a).

continuous, to weak and discontinuous. In some cases a weak reflection exists at the contact between the two formations; however, well control is generally necessary to correctly identify the contact. The Conejos-Blanco Basin package of reflections thins eastward to zero over the central high of the Alamosa basin.

Above the strong tuff reflections is a complex series of reflections corresponding to the Santa Fe Group. The Alamosa Formation is distinguished by low-amplitude, weak reflections typical of unconsolidated fine-grained lithologies. The transition to the lower Santa Fe Group is marked by a change to higher amplitude, more continuous reflections characteristic of interbedded coarse and fine clastic lithologies. The lower Santa Fe Group is characterized by two seismic packages, illustrated on Figure 9. The upper package is relatively flat lying and unfaulted, and traceable to some extent across the basin. The lowermost package dips moderately to the east, is

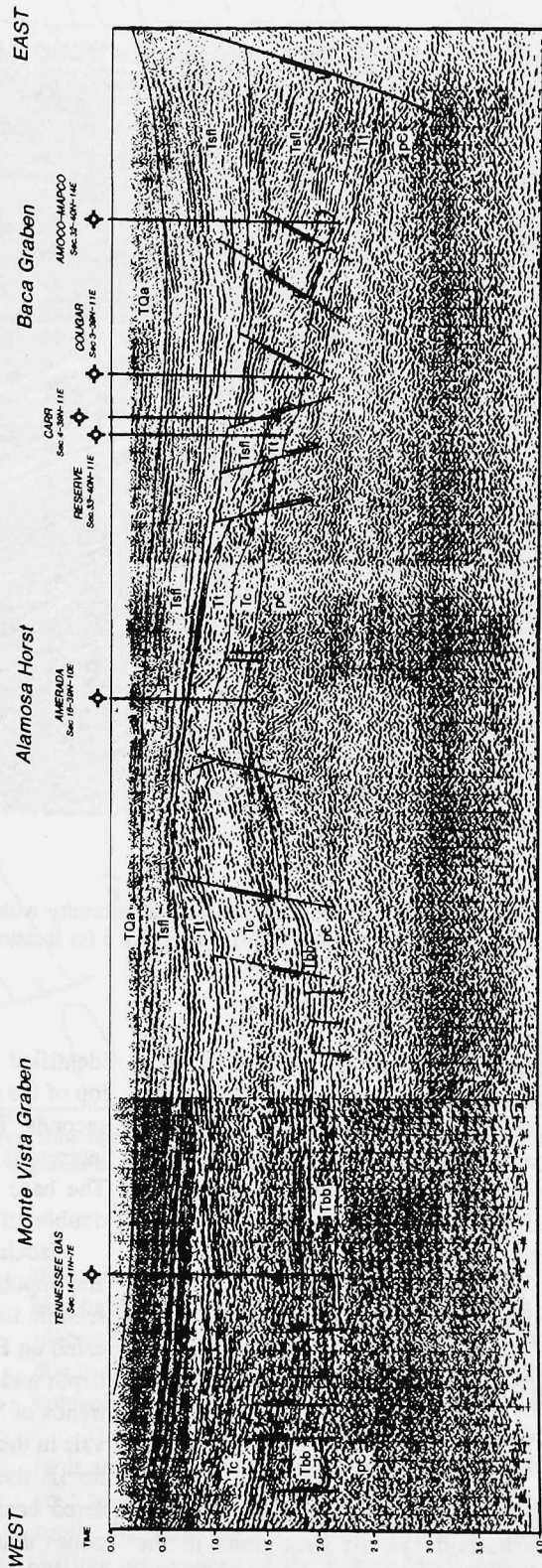

Figure 8. Seismic line 1, crosses the Alamosa basin from west to east (modified from Gries, 1985a; Gries and Brister, 1989). See Figure 3 for location and Figure 2 for abbreviations. Vertical scale in two-way travel time; see Figure 2 for approximate depth conversion.

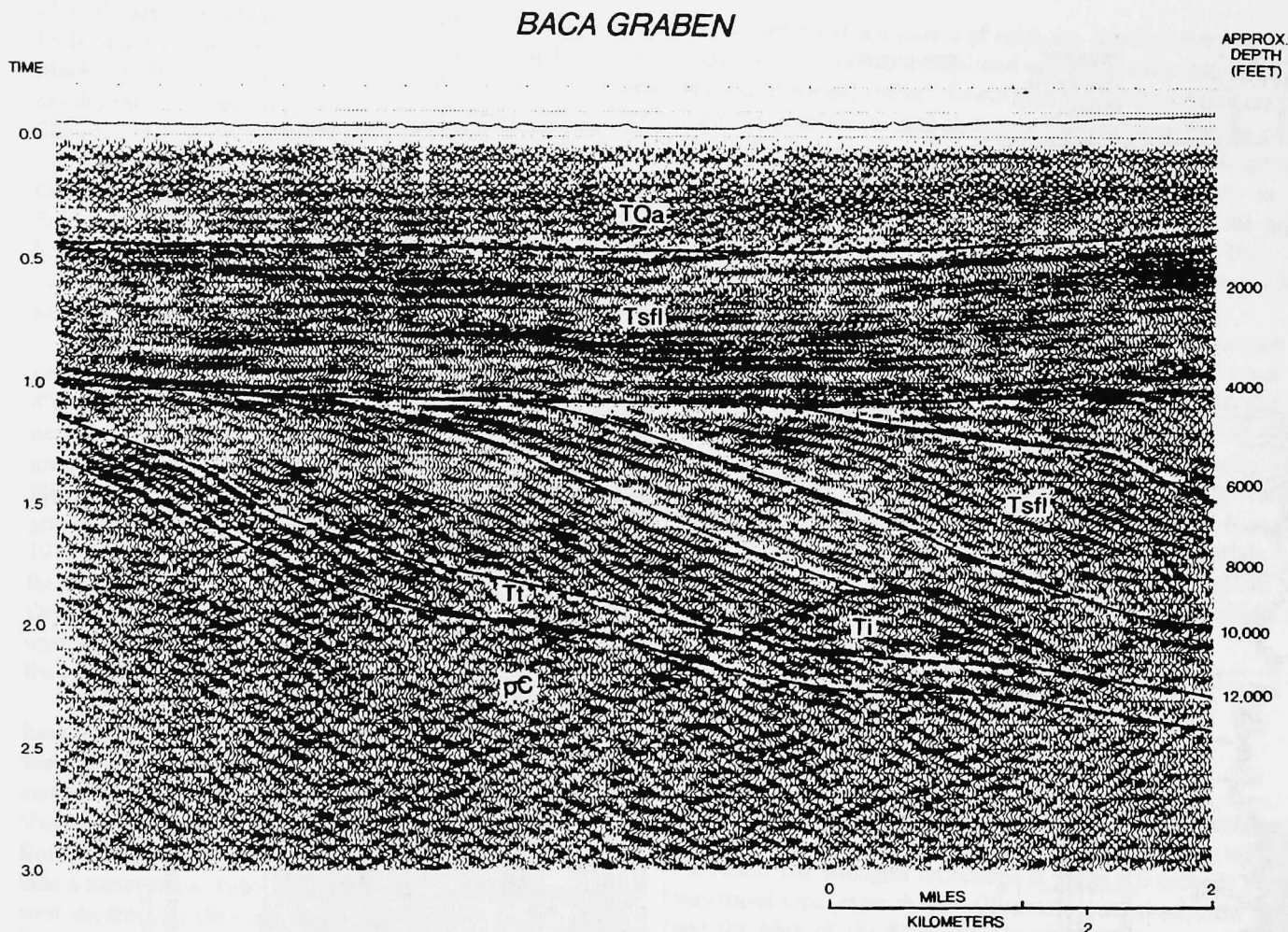

Figure 9. Seismic line 2, showing angular unconformity within the lower Santa Fe Group (after Gries, 1985a; Gries and Brister, 1989). See Figure 3 for location and Figure 2 for abbreviations. Ti, rhyolite intrusion.

highly faulted, and appears limited in extent to the Baca graben. The intervening angular unconformity within the lower Santa Fe Group can be seen on a number of seismic lines from the southern part of the Baca graben, and has some obvious implications for its early tectonic development. Although an increase in bed dip in the Baca graben is suggested in Figure 6 starting at about 1,400 m elevation, there is not an abrupt change in sample composition to mark this boundary. The mudstones and claystones common to the lower Santa Fe Group do not seem to radically change color across this boundary, although they do become reddened towards the base of the lower package.

#### *Isochron maps*

The presence of a recognizable, ubiquitous horizon that essentially separates pre-rift and syn-rift rock units in the Alamosa basin has great implications for reconstructing its tectonic history. The top and base of these intervals are readily

identified on the 350+ km of seismic lines in the basin. The top of the rift-related interval is simply a horizontal datum at 0 seconds. The base of the rift interval and the top of the pre-rift interval is the uppermost strong reflection of the tuff package. The base of the pre-rift Tertiary interval is the Precambrian double reflection.

Isochron maps made for these intervals from published and unpublished seismic lines are Figures 10 and 11. Published seismic lines used in constructing the isochron maps are indicated on Figure 3. The maps are not intended to show detailed depth and structure of the basin; rather, they illustrate general trends of "thickening" or increasing of the two-way time intervals in the grabens and "thinning" or decreasing of the intervals across the central basement high. No depth conversion is offered because of the scarcity of well control. Faults or fault zones that offset reflections within the intervals are indicated by dashed lines. These maps compare favorably with gravity studies conducted in the area (e.g., Keller et al., 1984).

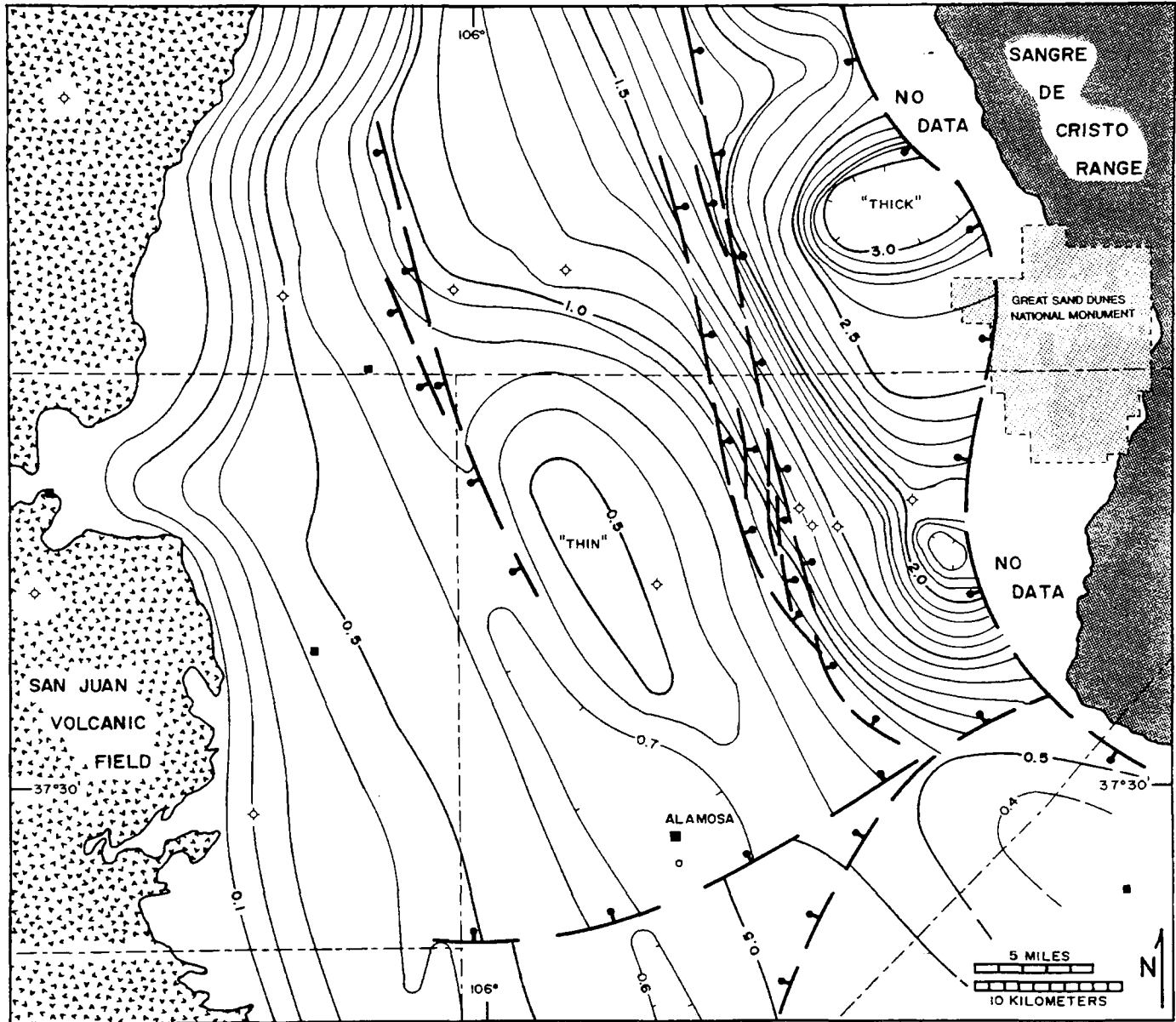

Figure 10. Isochron map: contoured two-way travel time interval between surface datum and top of Oligocene ash-flow tuff reflections. Fault zones depicted have demonstrated syn-rift displacement. Contour interval 0.1 seconds.

### Rift-basin geometry

The rift-related architecture of the Alamosa basin is essentially that of a first-order, east-tilted half graben (Figs. 8, 9, 10). All pre-rift lithostratigraphic units have been tilted eastward; however, tilting within the Baca graben is more pronounced than in the Monte Vista graben. The western hinge of the first-order rift graben exists within the San Juan volcanic field, west of the depositional basin (Lipman, 1975; Phillips, 1985). The western edge of the depositional basin is where volcanic units of the San Juan volcanic field dip into the basin beneath the Santa Fe Group. Faulting along this margin is

minor but has a distinctive style (Lipman, 1969). Faults generally have only a few meters or tens of meters of normal displacement and fault planes dip steeply to the west. However, due to the eastward dip of the beds, the net displacement of the volcanic rocks over the region is downward to the east.

The eastern boundary of the basin is the Sangre de Cristo fault zone. In plan view, it is concave towards the basin adjacent to the Great Sand Dunes National Monument. Farther south, the fault zone is convex toward the basin, forming the distinct promontory of the Blanca Peak massif. Based strictly on well control, the thickness of graben fill adjacent to the fault zone is at least 3 km. A seismic line by Stoughton (1977)

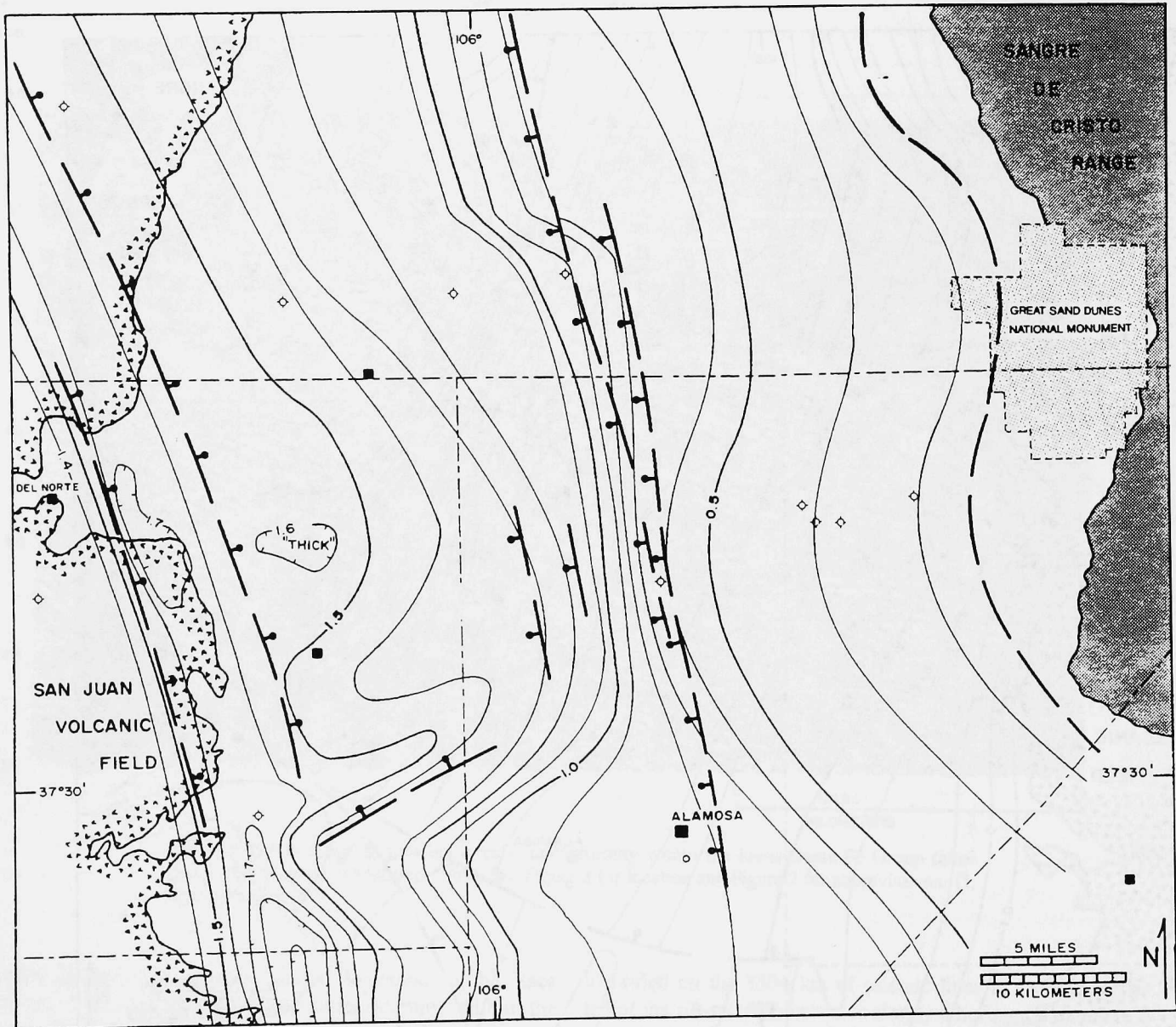

Figure 11. Isochron map: contoured two-way travel time interval between top of Oligocene ash-flow-tuff reflections and top of Precambrian reflections. Fault zones depicted have demonstrated pre-rift displacement. Contour interval 0.1 seconds.

indicates that the greatest thickness of fill exists in the Baca graben adjacent to the Sangre de Cristo fault zone near the Great Sand Dunes National Monument. A reasonable estimation of the depth of the basin at this locality is about 5.6 km. When the difference in elevation between the valley floor and the top of the Sangre de Cristo Range immediately adjacent to the dunes area (about 2 km) is added, the total vertical displacement of basement at the Sangre de Cristo fault zone is about 7.6 km. Basement relief has been estimated from gravity studies to be 7 km (Davis and Keller, 1978), approximately the estimate from seismic data in this paper. The fault plane

dips steeply ( $>45^\circ$ ) to the west and remains steeply dipping to the depths of resolution on seismic lines.

The southern boundary of the Alamosa basin is a probable accommodation zone between the Alamosa basin and the San Luis Hills, an intrabasin horst block that brings Oligocene volcanic rocks to the surface. The Baca graben is truncated at this zone, accounting for the great increase in isochron gradient at that location in Figure 10. South of this zone, the eastern graben is deflected some 20 km eastward to form the Culebra reentrant (Fig. 1).

The Alamosa basin is divided into the two second-order

half grabens by the central basement high, the Alamosa horst, which is not symmetrical. This north-trending feature is marked by high gravity and conspicuous thinning of syn-rift sediments. The eastern side of the "horst" is marked by a combination of strong eastward tilt of the basement and normal faults. The Alamosa horst is essentially the uptilted western edge of the east-tilted basement-cored crustal block flooring the Baca graben. The western margin of the "horst" is a hinge zone marked by monoclinical folding and less pronounced normal faulting of the ash-flow-tuff package (Figs. 2 and 8).

The high-gravity gradient on the western side of the Alamosa horst (e.g., Keller et al., 1984) is not the result of major rift-related block faulting as suggested by Tweto (1979) because faults along its western edge (Fig. 10) show relatively minor displacement of syn-rift units. Instead, the gravity gradient is attributable to pre-rift structural relief that developed along the eastern margin of the Paleogene precursor basin of the Monte Vista graben.

The syn-rift seismic interval over the horst area is "thinnest" west of the Amerada F-1 State well, but "thickens" northward along the trend of the horst. The basement high is not prominent on seismic lines in the northern part of the basin in the vicinity of the Carr #1 Kennedy Williams well (Stoughton, 1977). The positive gravity anomaly on Bouguer and residual gravity anomaly maps of Keller et al. (1984), thought to be a northern extension of the Alamosa horst, probably represents dense basement rock in this area. The only manifestation of the Alamosa horst in this location as seen in Figure 10 is a flattening of the east-sloping surface on top of the ash-flow-tuff package. Along the northern border of the study area, the Monte Vista graben and Alamosa horst essentially merge into an east-sloping bench, whereas the Baca graben continues to be a deep, narrow trough extending into the northernmost part of the San Luis Basin.

#### *Pre-rift basin*

Figure 11, the contoured two-way time interval between the top of the upper Oligocene tuffs and the top of the Precambrian, supports the observation that the area of the present Monte Vista graben was a depositional basin during the Paleogene. This basin was bounded on the east by a north-trending fault zone, paralleling a basement shoulder. This fault zone does not coincide exactly with the modern western margin of the Alamosa horst, but as mentioned above, is probably in part responsible for the steep gravity gradient between the present Monte Vista graben and the Alamosa horst.

The faults bounding the basin on the west, at about the longitude of Del Norte, are north-northwest trending. These faults created the structural relief that distinguishes the Del Norte high. Both the Blanco Basin and Conejos Formations appear to thicken eastward across this fault zone, indicating that it was active during their deposition. This fault zone was also active during rifting, but with an opposite sense of dis-

placement. The Paleogene basin appears to end southward at about the latitude of Alamosa. Its northern extent is probably in the vicinity of the town of Saguache, Colorado.

## **DISCUSSION: TECTONIC DEVELOPMENT**

### *Pre-Tertiary tectonic setting*

No post-Precambrian, pre-Eocene, strata exist in the boreholes studied. During the early and middle Paleozoic, the San Luis Basin region was part of a broad highland that lay to the south of the east-west-trending central Colorado sag of Eardley (1951, Plates 3, 4). Unfortunately, little evidence of the uplift or of deposition along its flanks has survived later tectonic events (Ross and Tweto, 1980). Parts of this highland were reactivated in Pennsylvanian to Permian time as the Uncompahgre-San Luis highland (Tweto, 1980), apparently bounded on the east by reactivated Precambrian structures (Sutherland, 1972; De Voto, 1980). This uplift was responsible for the coarse synorogenic deposits of the Sangre de Cristo Formation exposed in the Sangre de Cristo Range east of the Alamosa basin (De Voto, 1980). Denudation of the uplift continued until the Jurassic, when Middle to Late Jurassic nonmarine deposits lapped onto the old highland, eventually inundating it (Berman et al., 1980). Cretaceous nonmarine and marine strata were deposited over the area (Haun and Weimer, 1960) until onset of Laramide tectonism in latest Cretaceous time.

### *Laramide history*

The Laramide orogenic event, extending from late Campanian into Eocene time, was a period of uplift and erosion in a broad region including the San Luis Basin-Sangre de Cristo Range area and the Brazos uplift (Tweto, 1975), collectively referred to here as the San Luis-Brazos uplift. Two pulses of uplift are recorded in the synorogenic sedimentary deposits of the San Juan sag and San Juan Basin. The first pulse, marked by the Animas Formation (Upper Cretaceous-Paleocene), initiated uplift of the region and stripping of post-Precambrian strata from the San Luis-Brazos uplift. The Animas Formation contains volcanic detritus recording nearby Laramide volcanic activity, but it becomes increasingly arkosic upwards in its section, indicating that the uplift was being unroofed to expose its Precambrian core (Brister and Chapin, 1994). The known fault style of the eastern part of the uplift was that of west-dipping reverse faults that flatten at depth (Lindsey et al., 1983), and low-angle thrust faults (Schavran, 1984). The Del Norte high is probably a remnant of the western flank of the uplift.

An angular unconformity between the Animas and the Blanco Basin Formations indicates that a second pulse of tectonic activity began in late Paleocene, extending into the Eocene (Cather and Chapin, 1990). North-northeast translation of the Colorado Plateau during late Laramide time resulted in wrenching in a north-south zone along the axis of the Southern

Rocky Mountains in New Mexico and Colorado (Chapin and Cather, 1981; Chapin, 1983) and north-south compression within uplifts in Wyoming (Gries, 1983, 1990). This episode involved reactivation of the western margin of the San Luis-Brazos uplift due to development of a wrench-fault system, creation of a basin over the western half of the former uplift, and rejuvenation of sedimentation westward into the San Juan sag-San Juan Basin areas (Brister and Chapin, 1994).

The Blanco Basin Formation depocenter, which was probably wrench-fault related (Brister and Chapin, 1994), formed within the western part of San Luis-Brazos uplift. This basin is classified as an Echo Park-type basin (terminology of Chapin and Cather, 1981) or as an axial basin (Dickinson et al., 1988). The Eocene basin was approximately 20 to 25 km wide and at least 60 km long in a north-northwest trend with its thickest preserved deposits existing along the fault system on the west side. It may have had an open drainage connection to the San Juan sag to the west.

The effect of 30+ m.y. of Laramide uplift and erosion of the San Luis-Brazos uplift was to subdue the mountain chain and fill the adjacent basins, resulting in the development of a wide-ranging, low-relief, geomorphic surface in the region (Steven, 1975), referred to as the late Eocene erosion surface of Epis and Chapin (1975). This surface is now buried deeply beneath Oligocene volcanic strata; it was developed on the Blanco Basin Formation in the western half of the basin and the eroded Precambrian basement in the eastern half. An unconformity marks the late Eocene erosion surface between the top of the Blanco Basin Formation and volcanoclastic rocks of the basal Conejos Formation. There is only minor angularity visible between the two formations on seismic lines. Most drill cuttings from the lowermost Conejos Formation contain minor amounts of basement detritus, either removed from remnant high areas or reworked from Blanco Basin sediments. Oligocene stream channels eroded into the Eocene surface in Colorado have been described by Epis et al. (1980).

### *Oligocene volcanism*

The Oligocene was a time of widespread andesitic volcanism in a north-trending band along the axis of the Southern Rocky Mountains. This period of volcanism has been attributed to rising magmas in a continental-arc tectonic setting during a change from a flat-dipping to a steep-dipping subduction zone along the western North American margin (Lipman, 1983a). During this event, several kilometers of volcanic rocks were deposited in the San Juan volcanic field. As illustrated in Figures 2 and 8, the faults bounding the Paleogene basin in the western half of the Alamosa basin were reactivated during Conejos deposition.

By 29 Ma, a period of extension had begun in southern Colorado, marked by north-northeast-trending dikes in the San Luis Hills mapped by Bartlett (1984) and dated by Burroughs (1972). Volcanism accompanying this early period

of extension was primarily associated with caldera formation in the San Juan volcanic field and emplacement of regional ash-flow sheets, such as those deposited across the Alamosa basin. This early extension preceded development of rift-related half grabens.

### *Neogene rifting*

Indicators of the beginning of the Rio Grande rift event have been discussed in some detail by Chapin (1971, 1979, 1988). Initiation of rifting in the Alamosa basin is fairly well constrained by the stratigraphy of its western margin. Structures directly associated with rifting were not active until after emplacement of the uppermost Oligocene ash-flow tuff (Carpenter Ridge Tuff, 27.35 Ma, Lipman, 1989). Several lines of evidence support this conclusion. First, there is no evidence that the pre-27-Ma ash-flow sheets ponded in areas soon to become grabens. Secondly, sediments deposited between the ash-flow sheets thin eastward, indicating that the Baca graben had not yet begun to form. Where these sediments are thickest is in an area of structural sagging along the western edge of the present Monte Vista graben. There is no evidence that sagging in that vicinity continued after initiation of rifting. Also, where faults cut the Oligocene tuffs, they cut across the entire package. As seen on reflection seismic lines, the lower tuffs in the package are not more highly faulted than upper tuffs. This indicates that the entire tuff package was emplaced prior to significant local rift faulting.

The rift event began at about 27 Ma. This conclusion is supported by several observations. At about this time, the composition of regional volcanism changed from dacitic to basaltic. The Hinsdale basalts (as old as 26.8 Ma) lie atop the ash-flow tuffs of the San Juan volcanic field in angular unconformity (Lipman and Mehnert, 1975; Lipman, 1975, 1976). Following emplacement of the basalts, the eastern edge of the San Juan volcanic field was uplifted, tilted eastward, and deeply eroded. Other dated evidence for initiation of rifting is the 26.5-Ma Amalia Tuff (Lipman et al., 1986; Lipman, 1988) interbedded with the Los Pinos Formation in the Tusas Mountains along the west side of the southern San Luis Basin (Lipman, 1983b; Manley, 1981).

During early rifting the eastern half of the Alamosa basin was progressively tilted eastward along the Sangre de Cristo Range. The Sangre de Cristo fault zone was probably controlled by the thrust root zones of the Laramide San Luis uplift (Sales, 1983). Seismic lines and cross sections illustrate episodic faulting on the basin-bounding faults during the rift event. This is demonstrated in angular relationships within the lower Santa Fe Group and the cyclic pattern of alternating coarse and fine deposition. Streams flowing from the San Juan volcanic field carrying a coarse volcanic load emptied into the Alamosa basin, developing alluvial fans at their mouths, perhaps much like the modern alluvial fan constructed where the Rio Grande enters the San Luis Basin at the town of Del

Norte. A broad piedmont extended as a veneer eastwards across the western half of the basin towards the eastern (Baca) narrow graben.

The Sangre de Cristo Range also supplied material to the basin. Shorter, steeper alluvial fans were constructed along the eastern margin of the Baca graben. Rift half grabens such as the Baca graben tend to develop axial drainage systems that closely parallel the faulted margin of the graben due to increased subsidence along the margin (Leeder and Gawthorpe, 1987; Mack and Seager, 1990). The sediment load from alluvial fans is redistributed within such axial stream systems. This probably accounts for the mix of Precambrian and volcanic detritus in the lower Santa Fe Group of the Baca graben. The fault-slice of lower Santa Fe Group cropping out on the western edge of Blanca Peak (Urraca outcrop, Fig. 3) contains current indicators suggesting stream deposition parallel to the basin margin. Recent fission-track dating of apatite in Precambrian rocks making up Blanca Peak indicate rapid uplift of the Blanca massif between 28 and 18 Ma (Kelley, 1990). This probably coincided with rapid subsidence and eastward tilting of the Baca half graben.

The angular unconformity visible in Figure 9 is evidence for a change in fault activity and degree of tilting of the Baca graben. Sediments above this unconformity are only gently tilted, and not as intensely faulted as the lowermost package of Santa Fe rocks. The basin-spanning coarse units above the lower Santa Fe Group (Fig. 6) represents response of drainage systems to this period of truncation of previously deposited sediments. By about 4.5 Ma, the through drainage from the northern to southern parts of the San Luis Basin was impeded by the intervening Servilleta flood basalts of the Taos Plateau.

## REFERENCES CITED

- Baltz, E. H., 1965, Stratigraphy and history of Raton Basin and notes on San Luis Basin, Colorado—New Mexico: *Bulletin of the American Association of Petroleum Geologists*, v. 49, p. 2041–2075.
- Bartlett, R. D., 1984, Geology of an Oligocene-age acid hot-spring, San Luis Hills, Conejos and Costilla Counties, Colorado [M.S. thesis]: Fort Collins, Colorado State University, 111 p.
- Berman, A. E., Poleschok, D., and Dimelow, T. E., 1980, Jurassic and Cretaceous systems of Colorado, in Kent, H. C., and Porter, K. W., eds., *Colorado geology: Denver, Colorado, Rocky Mountain Association of Geologists*, p. 111–128.
- Brister, B. S., 1990, Tertiary sedimentation and tectonics: San Juan sag—San Luis Basin region, Colorado and New Mexico [Ph.D. thesis]: Socorro, New Mexico Institute of Mining and Technology, 267 p.
- Brister, B. S., 1992, The Blanco Basin Formation (Eocene), San Juan Mountains region, Colorado and New Mexico, in Lucas, S. J., and 3 others, eds., *San Juan Basin IV: New Mexico Geological Society 43rd Annual Field Conference, Guidebook*, p. 321–331.
- Brister, B. S., and Chapin, C. E., 1994, Sedimentation and tectonics of the Laramide San Juan sag, southwestern Colorado: *The Mountain Geologist*, v. 31, p. 2–18.
- Burroughs, R. L., 1971, Geology of the San Luis hills, south-central Colorado, in James, H. L., ed., *Guidebook of the San Luis Basin, Colorado: New Mexico Geological Society 22nd Field Conference, Guidebook*, p. 277–287.
- Burroughs, R. L., 1972, Geology of the San Luis hills, south-central Colorado [Ph.D. thesis]: Albuquerque, University of New Mexico, 140 p.
- Burroughs, R. L., 1981, A summary of the geology of the San Luis Basin, Colorado and New Mexico, with emphasis on the geothermal potential for the Monte Vista graben: *Colorado Geological Survey Special Publication 17*, 30 p.
- Butler, A. P., Jr., 1946, Tertiary and Quaternary geology of the Tusas—Tres Piedras area, New Mexico [Ph.D. thesis]: Cambridge, Massachusetts, Harvard University, 188 p.
- Butler, A. P., Jr., 1971, Tertiary volcanic stratigraphy of the eastern Tusas Mountains, southwest of the San Luis Valley, Colorado—New Mexico, in James, H. L., ed., *Guidebook of the San Luis Basin: New Mexico Geological Society, 22nd Annual Field Conference, Guidebook*, p. 289–300.
- Cather, S. M., and Chapin, C. E., 1990, Paleogeographic and paleotectonic setting of Laramide sedimentary basins in the central Rocky Mountain region: Alternative interpretation: *Geological Society of America Bulletin*, v. 102, p. 256–258.
- Chapin, C. E., 1971, The Rio Grande rift; Part I. Modifications and additions, in James, H. L., ed., *Guidebook of the San Luis Basin, Colorado: New Mexico Geological Society, 22nd Annual Field Conference, Guidebook*, p. 191–201.
- Chapin, C. E., 1979, Evolution of the Rio Grande rift, A summary, in Riecker, R. E., ed., *Rio Grande rift: Tectonics and magmatism: Eos Transactions*

Internal drainage created conditions for fluviolacustrine sedimentation common to the Alamosa Formation (Rogers et al., 1992).

Elsewhere in the rift at this time, basins were being integrated into the ancestral Rio Grande. By middle Pleistocene time, integration of the upper Rio Grande drainage system with the lower Rio Grande system (Gulf of Mexico terminus) in the Trans-Pecos Texas region below El Paso, caused lowering of base levels, dissection of basins, and stranding of geomorphic surfaces (Gile et al., 1981). The Rio Grande integrated basins as far north as Red River of New Mexico (Wells et al., 1987). The Servilleta basalts north of the Red River and the San Luis Hills horst served as a hydrologic divide until middle to late Pleistocene when the Rio Grande was able to erode a gorge through these barriers. This event occurred after 0.69 Ma, the youngest documented age of the Alamosa Formation (Rogers et al., 1985), but before 0.3 Ma (Wells et al., 1987).

## ACKNOWLEDGMENTS

This paper resulted from a dissertation by the senior author at the New Mexico Institute of Mining and Technology, which was directed by Charles Chapin and funded by the New Mexico Bureau of Mines and Mineral Resources. The authors wish to thank Charles Chapin and Chuck Kluth for their critical reviews. We also thank Steve Cather, Matthew Golombek, John Hawley, Raymond Ingersoll, and Peter Lipman for suggestions that improved the manuscript. Amarex Inc. and Reserve Oil provided seismic data and Randy Ray contributed the synthetic seismogram.

- of the American Geophysical Union, p. 1-5.
- Chapin, C. E., 1983, An overview of Laramide wrench faulting in the Southern Rocky Mountains with emphasis on petroleum exploration, *in* Lowell, J. D., ed., *Rocky Mountain foreland basins and uplifts: Rocky Mountain Association of Geologists*, p. 169-179.
- Chapin, C. E., 1988, Axial basins of the northern and central Rio Grande rifts, *in* Sloss, L. L., ed., *Sedimentary cover, North American craton: U.S.: Geological Society of America*, p. 165-170.
- Chapin, C. E., and Cather, S. M., 1981, Eocene tectonics and sedimentation in the Colorado Plateau-Rocky Mountain region, *in* Dickinson, W. R., and Payne, W. D., eds., *Relations of tectonics to ore deposits in the Southern Cordillera: Arizona Geological Society Digest*, v. 14, p. 173-189.
- Chapin, C. E., and Lindley, J. L., 1986, Potassium metasomatism of igneous and sedimentary rocks in detachment terranes and other sedimentary basins: Economic implications: *Arizona Geological Society Digest*, v. XVI, p. 118-126.
- Cordell, L., 1978, Regional geophysical setting of the Rio Grande rift: *Geological Society of America Bulletin*, v. 89, p. 1073-1090.
- Covarrubias, O., 1988, An integrated geological and geophysical study of the structural boundary between the San Luis Basin and the San Juan sag, south-central Colorado [M.S. thesis]: Golden, Colorado School of Mines, 72 p.
- Cross, W., and Larsen, E. S., 1935, A brief review of the geology of the San Juan region of southwestern Colorado: *U.S. Geological Survey Bulletin* 843, 138 p.
- Davis, G. H., and Keller, G. R., 1978, Subsurface structure of San Luis Valley, *in* Hawley, J. W., ed., *Guidebook to Rio Grande rift in New Mexico and Colorado: New Mexico Bureau of Mines and Mineral Resources Circular* 163, p. 28.
- De Voto, R. H., 1980, Pennsylvanian stratigraphy and history of Colorado, *in* Kent, H. C., and Porter, K. W., eds., *Colorado geology: Rocky Mountain Association of Geologists*, p. 71-101.
- Dickinson, W. R., and 6 others, 1988, Paleogeographic and paleotectonic setting of Laramide sedimentary basins in the central Rocky Mountain region: *Geological Society of America Bulletin*, v. 100, p. 1023-1039.
- Eardley, H. J., 1951, *Structural geology of North America*: New York, Harper and Row, 743 p.
- Epis, R. C., and Chapin, C. E., 1974, Stratigraphic nomenclature of the Thirtynine Mile volcanic field, central Colorado: *U.S. Geological Survey Bulletin* 1395-C, 23 p.
- Epis, R. C., and Chapin, C. E., 1975, Geomorphic and tectonic implications of the post-Laramide, late Eocene erosion surface in the Southern Rocky Mountains, *in* Curtis, B. F., ed., *Cenozoic history of the Southern Rocky Mountains: Geological Society of America Memoir* 144, p. 45-74.
- Epis, R. C., Scott, G. R., Taylor, R. B., and Chapin, C. E., 1980, Summary of Cenozoic geomorphic, volcanic and tectonic features of central Colorado and adjoining areas, *in* Kent, H. C., and Porter, K. W., eds., *Colorado geology: Rocky Mountain Association of Geologists*, p. 135-156.
- Folk, R. L., 1974, *Petrology of sedimentary rocks*: Austin, Texas, Hemphill Publishing Co., 184 p.
- Gile, L. H., Hawley, J. W., and Grossman, R. B., 1981, Soils and geomorphology in the Basin and Range area of Southern New Mexico—Guidebook to the Desert Project: *New Mexico Bureau of Mines and Mineral Resources Memoir* 39, 222 p.
- Gries, R., 1983, North-south compression of Rocky Mountain foreland structures, *in* Lowell, J. D., ed., *Rocky Mountain foreland basins and uplifts: Denver, Colorado, Rocky Mountain Association of Geologists*, p. 9-32.
- Gries, R. R., 1985a, Seismic lines in the San Luis Valley, south-central Colorado, *in* Gries, R. R., and Dyer, R. C., eds., *Seismic exploration of the Rocky Mountain region: Rocky Mountain Association of Geologists and Denver Geophysical Society*, p. 267-274.
- Gries, R. R., 1985b, San Juan sag: Cretaceous rocks in a volcanic-covered basin, south-central Colorado: *The Mountain Geologists*, v. 22, p. 167-179.
- Gries, R. R., 1989, San Juan sag: Oil and gas exploration in a newly discovered basin beneath the San Juan volcanic field, *in* Lorenz, J. C., and Lucas, S. G., eds., *Energy frontiers in the Rockies: Albuquerque Geological Society*, p. 69-78.
- Gries, R. R., 1990, Rocky Mountain foreland structures: Changes in compression direction through time, *in* Letouzey, J., ed., *Petroleum and tectonics in mobile belts: Paris, Editions Technip*, p. 129-148.
- Gries, R. R., and Brister, B. S., 1989, New interpretation of seismic lines in the San Luis Valley, south-central Colorado, *in* Harmon, E. J., ed., *Water in the valley: Colorado Ground-Water Association, 8th Annual Field Trip, Guidebook*, p. 241-254.
- Gries, R. R., and Vandersluis, G. D., 1989, Laramide and Cenozoic geology: *Rocky Mountain Association of Geologists Field Trip Road Log*, 90 p.
- Hanna, T. M., and Harmon, E. J., 1989, An overview of the historical, stratigraphic, and structural setting of the aquifer system of the San Luis Valley, *in* Harmon, E. J., ed., *Water in the valley: Colorado Ground-water Association, 8th Annual Field Trip, Guidebook*, p. 1-34.
- Haun, J. D., and Weimer, R. J., 1960, Cretaceous stratigraphy of Colorado, *in* Weimer, R. J., and Haun, J. D., eds., *Guide to geology of Colorado: Geological Society of America, Rocky Mountain Association of Geologists, Colorado Scientific Society*, p. 58-65.
- Hawley, J. W., 1978, *Guidebook to Rio Grande rift in New Mexico and Colorado: New Mexico Bureau of Mines and Mineral Resources Circular* 163, 241 p.
- Huntley, D., 1976, Ground water recharge to the aquifers of northern San Luis Valley, Colorado: A remote sensing investigation [Ph.D. thesis]: Golden, Colorado School of Mines, 240 p.
- Huntley, D., 1979, Cenozoic faulting and sedimentation in northern San Luis Valley, Colorado: *Summary: Geological Society of America Bulletin*, v. 90, p. 8-12.
- Ingersoll, R. V., Cavazza, W., Baldrige, W. S., Shafiqullah, M., 1990, Cenozoic sedimentation and peletectonics of north-central New Mexico: Implications for initiation and evolution of the Rio Grande rift: *Geological Society of America Bulletin*, v. 102, p. 1280-1296.
- Johnson, R. B., 1969, *Geologic map of the Trinidad Quadrangle south-central Colorado: U.S. Geological Survey Miscellaneous Investigations Map* I-558, scale 1:250,000.
- Keller, G. R., Cordell, L., Davis, G. H., Peeples, W. J., and White, G., 1984, A geophysical study of the San Luis Basin, *in* Baldrige, W. S., and 3 others, eds., *Rio Grande rift: Northern New Mexico: New Mexico Geological Society, 35th Annual Field Conference, Guidebook*, p. 51-57.
- Kelley, S. A., 1990, Late Mesozoic to Cenozoic cooling history of the Sangre de Cristo Mountains: *New Mexico Geological Society, 41st Annual Field Conference, Guidebook*, p. 123-132.
- Kelley, V. C., 1956, The Rio Grande depression from Taos to Santa Fe, *in* Rosenzweig, A., ed., *Southeastern Sangre de Cristo Mountains: New Mexico Geological Society, 7th Annual Field Conference, Guidebook*, p. 109-114.
- Kluth, C. F., and Schaftenaar, C. H., 1989, Seismic record section and interpretation of Line 2, *in* Callender, J. F., Hawley, J. W., and Keller, G. R., eds., *Rio Grande rift: 28th International Geological Congress Field Trip, Guidebook* T318, p. 25.
- Knepper, D. H., 1976, Late Cenozoic structure of the Rio Grande rift zone, central Colorado, *in* Epis, R. C., and Weimer, R. J., eds., *Studies in Colorado field geology: Golden, Colorado School of Mines Professional contributions*, no. 8, p. 421-430.
- Knepper, D. H., and Marrs, R. W., 1971, Geological development of the Bonanza-San Luis Valley-Sangre de Cristo Range area, south-central Colorado, *in* James, H. L., ed., *Guidebook of the San Luis Basin, Colorado: New Mexico Geological Society, 22nd Annual Field Trip, Guidebook*, p. 249-264.
- Larsen, E. S., and Cross, W., 1956, *Geology and petrology of the San Juan region southwestern Colorado: U.S. Geological Survey Professional Paper* 258, 303 p.
- Leeder, M. R., and Gawthorpe, R. L., 1987, *Sedimentary models for extensional tectonics: A review of the literature*: London, Geological Society, 100 p.

- sional tilt-block/half graben basins: Geological Society of London Special Publication 28, p. 139–152.
- Lindsey, D. A., Johnson, B. R., and Andriessen, P.A.M., 1983, Laramide and Neogene structure of the northern Sangre de Cristo Range, south-central Colorado, in Lowell, J. D., ed., Rocky Mountain foreland basins and uplifts: Denver, Colorado, Rocky Mountain Association of Geologists, p. 219–228.
- Lipman, P. W., 1968, Geology of Summer Coon volcanic center, eastern San Juan Mountains, Colorado, in Epis, R. C., ed., Cenozoic volcanism in the Southern Rocky Mountains: Colorado School of Mines Quarterly, v. 63, p. 211–236.
- Lipman, P. W., 1969, Alkalic and tholeiitic basaltic volcanism related to the Rio Grande depression, southern Colorado and northern New Mexico: Geological Society of America, v. 80, p. 1343–1354.
- Lipman, P. W., 1975, Evolution of the Platoro caldera complex and related volcanic rocks, southeastern San Juan Mountains, Colorado: U.S. Geological Survey Professional Paper 852, 128 p.
- Lipman, P. W., 1976, Geologic map of the Del Norte area, eastern San Juan Mountains, Colorado: U.S. Geological Survey Miscellaneous Investigations Series Map I-952, scale 1:48,000.
- Lipman, P. W., 1983a, Tectonic setting of the mid to late Tertiary in the Rocky Mountain region—A review, in The genesis of Rocky Mountain ore deposits: Changes with time and tectonics: Denver Region Exploration Geologists Society, p. 125–131.
- Lipman, P. W., 1983b, The Miocene Questa caldera, northern New Mexico: Relation to batholith emplacement and associated molybdenum mineralization, in The genesis of Rocky Mountain ore deposits: Changes with time and tectonics: Denver Region Exploration Geologists Society, p. 133–149.
- Lipman, P. W., 1988, Evolution of silicic magma in the upper crust: The mid-Tertiary Latir volcanic field and its cogenetic granitic batholith, northern New Mexico, U.S.A.: Transactions of the Royal Society of Edinburgh: Earth Sciences, v. 79, p. 265–288.
- Lipman, P. W., ed., 1989, Oligocene-Miocene San Juan volcanic field, Colorado, in Chapin, C. E., and Zidek, J., eds., Field excursions to volcanic terranes in the western United States, Volume I: Southern Rocky Mountains: New Mexico Bureau of Mines and Mineral Resources Memoir 46, p. 303–380.
- Lipman, P. W., and Mehnert, H. H., 1975, Late Cenozoic basaltic volcanism and development of the Rio Grande depression in the Southern Rocky Mountains, in Curtis, B. F., ed., Cenozoic history of the Southern Rocky Mountains: Geological Society of America Memoir 144, p. 119–154.
- Lipman, P. W., and Mehnert, H. H., 1979, The Taos Plateau volcanic field, northern Rio Grande rift, New Mexico, in Riecker, R. E., ed., Rio Grande rift, Tectonics and magmatism: EOS Transactions of the American Geophysical Union, p. 289–310.
- Lipman, P. W., and Steven, T. A., 1970, Reconnaissance geology and economic significance of the Platoro caldera, southeastern San Juan Mountains, Colorado, in Geological Survey research 1970: U.S. Geological Survey Professional Paper 700-C, p. 19–C29.
- Lipman, P. W., Steven, T. A., and Mehnert, H. H., 1970, Volcanic history of the San Juan Mountains, Colorado, as indicated by potassium-argon dating: Geological Society of America Bulletin, v. 81, p. 2329–2352.
- Lipman, P. W., Mehnert, H. H., and Naeser, C. W., 1986, Evolution of the Latir volcanic field, northern New Mexico and its relation to the Rio Grande rift, as indicated by potassium-argon and fission track dating: Journal of Geophysical Research, v. 91, p. 6329–6345.
- Mack, G. H., and Seager, W. R., 1990, Tectonic control on facies distribution of the Camp Rice and Palomas Formations (Pliocene-Pleistocene in the southern Rio Grande rift): Geological Society of America Bulletin, v. 102, p. 45–53.
- Manley, K., 1981, Redefinition and description of the Los Pinos Formation of north-central New Mexico: Geological Society of America Bulletin, Part 1, v. 92, p. 984–989.
- Olson, J. C., Hedlund, D. C., and Hansen, W. R., 1968, Tertiary volcanic stratigraphy in the Powderhorn–Black Canyon region, Gunnison and Montrose Counties, Colorado: U.S. Geological Survey Bulletin 1251-C, 29 p.
- Personius, S. F., and Machette, M. N., 1984, Quaternary and Pliocene faulting in the Taos Plateau region, northern New Mexico, in Baldrige, W. S., and 3 others, eds., Rio Grande rift: Northern New Mexico: New Mexico Geological Society, 35th Annual Field Conference, Guidebook, p. 83–90.
- Phillips, D. H., 1985, A geophysical investigation of the southeastern San Juan Mountains, Colorado [M.S. thesis]: Golden, Colorado School of Mines, 69 p.
- Powell, W. J., 1958, Ground-water resources of the San Luis Valley, Colorado: U.S. Geological Survey Water-Supply Paper 1379, 284 p.
- Rider, M. H., 1986, The geological interpretation of well logs: New York, Halstead Press, 175 p.
- Rogers, K. L., 1984, A paleontological analysis of the Alamosa Formation (south-central Colorado: Pleistocene: Irvingtonian), in Baldrige, W. S., Dickerson, P. W., Riecker, R. E., and Zidek, J., eds., Rio Grande rift: Northern New Mexico: New Mexico Geological Society, 35th Annual Field Conference, Guidebook, p. 151–155.
- Rogers, K. L., and 7 others, 1985, Middle Pleistocene (late Irvingtonian–Nebraskan) climatic changes in south-central Colorado: National Geographic Review, v. 1, p. 535–563.
- Rogers, K. L., and 11 others, 1992, Pliocene and Pleistocene geologic and climatic evolution in the San Luis Valley of south-central Colorado: Palaeogeography, Palaeoclimatology, Palaeoecology, v. 94, p. 55–96.
- Ross, R. J., and Tweto, O., 1980, Lower Paleozoic sediments and tectonics in Colorado, in Kent, H. C., and Porter, K. W., eds., Colorado geology: Denver, Colorado, Rocky Mountain Association of Geologists, p. 47–56.
- Sales, J. K., 1983, Collapse of Rocky Mountain basement uplifts, in Lowell, J. D., ed., Rocky Mountain foreland basins and uplifts: Denver, Colorado, Rocky Mountain Association of Geologists, p. 79–97.
- Schavran, G., 1984, Structural features of a Laramide fold and thrust belt, east flank of the Sangre de Cristo Range, Colorado [M.S. thesis]: Golden, Colorado School of Mines, 67 p.
- Scott, G. R., 1975, Cenozoic surfaces and deposits in the Southern Rocky Mountains, in Curtis, B. F., ed., Cenozoic history of the Southern Rocky Mountains: Geological Society of America Memoir 144, p. 227–248.
- Siebenthal, C. E., 1910a, The San Luis Valley, Colorado: Science, v. 31, p. 744–746.
- Siebenthal, C. E., 1910b, Geology and water resources of the San Luis Valley, Colorado: U.S. Geological Survey Water-Supply Paper 240, 128 p.
- Spiegel, Z., and Baldwin, B., 1963, Geology and water resources of the Santa Fe area, New Mexico: U.S. Geological Survey Water-Supply Paper 1525, 258 p.
- Steven, T. A., 1975, Middle Tertiary volcanic field in the Southern Rocky Mountains, in Curtis, B. F., ed., Cenozoic history of the Southern Rocky Mountains: Geological Society of America Memoir 144, p. 75–94.
- Steven, T. A., and Lipman, P. W., 1976, Calderas of the San Juan volcanic field, southwestern Colorado: U.S. Geological Survey Professional Paper 958, 35 p.
- Steven, T. A., Mehnert, H. H., and Obradovich, J. D., 1967, Age of volcanic activity in the San Juan Mountains, Colorado: U.S. Geological Survey Professional Paper 575-D, p. D47–D55.
- Steven, T. A., Lipman, P. W., Hail, W. J., Barker, F., and Luedke, R. G., 1974, Geologic map of the Durango Quadrangle, southwestern Colorado: U.S. Geological Survey Miscellaneous Geologic Investigations Map I-764, scale 1:250,000.
- Stoughton, D., 1977, Interpretation of seismic reflection data from the San Luis valley, south-central Colorado [M.S. thesis]: Golden, Colorado School of Mines, 100 p.
- Sutherland, P. K., 1972, Pennsylvanian stratigraphy, southern Sangre de Cristo Mountains, New Mexico, in Mallory, W. W., and 25 others, eds., Geologic atlas of Rocky Mountain region: Denver, Colorado, Rocky Mountain Association of Geologists, p. 139–142.

- Taylor, R. B., 1975, Neogene tectonism in south-central Colorado, *in* Curtis, B. F., ed., *Cenozoic history of the Southern Rocky Mountains: Geological Society of America Memoir 144*, p. 211–226.
- Thompson, R. A., and Machette, M. N., 1989, Geologic map of the San Luis Hills area, Conejos and Costilla Counties, Colorado: U.S. Geological Survey Miscellaneous Investigations Series Map I-1906, scale 1:50,000.
- Tweto, O., 1961, Late Cenozoic events of the Leadville district and Upper Arkansas Valley, Colorado: U.S. Geological Survey Professional Paper 424-B, p. B133–135.
- Tweto, O., 1975, Laramide (Late Cretaceous–early Tertiary) orogeny in the Southern Rocky Mountains, *in* Curtis, B. F., ed., *Cenozoic history of the Southern Rocky Mountains: Geological Society of America Memoir 144*, p. 1–44.
- Tweto, O., 1979, The Rio Grande rift system in Colorado, *in* Riecker, R. E., ed., *Rio Grande rift: Tectonics and magmatism: EOS Transactions of the American Geophysical Union*, p. 33–56.
- Tweto, O., 1980, Tectonic history of Colorado, *in* Kent, E. C., and Porter, K. W., eds., *Colorado geology: Denver, Colorado, Rocky Mountain Association of Geologists*, p. 5–9.
- Upson, J. E., 1939, Physiographic subdivisions of the San Luis Valley, southern Colorado: *Journal of Geology*, v. 47, p. 721–736.
- Upson, J. E., 1941, The Vallejo Formation: New early Tertiary red-beds in southern Colorado: *American Journal of Science*, v. 239, p. 577–589.
- Valencia, R. S., 1983, An integrated geophysical study of the west-central part of San Luis Valley, Colorado [M.S. thesis]: Golden, Colorado School of Mines, 92 p.
- Van Alstine, R. E., 1968, Tertiary trough between the Arkansas and San Luis Valleys, Colorado: U.S. Geological Survey Professional Paper 600-C, p. C158–C160.
- Van Alstine, R. E., 1970, Allochthonous Paleozoic blocks in the Tertiary San Luis–Upper Arkansas graben, Colorado: U.S. Geological Survey Professional Paper 700-B, p. B43–51.
- Wells, S. G., Kelson, K. I., and Menges, C. M., 1987, Quaternary evolution of fluvial systems in the northern Rio Grande Rift, New Mexico and Colorado: Implications for entrenchment and integration of drainage systems, *in* Menges, C. M., ed., *Quaternary tectonics, landform evolution, soil chronologies and glacial deposits—northern Rio Grande rift of New Mexico: Friends of the Pleistocene–Rocky Mountain Cell Field Trip, Guidebook*, p. 55–69.

MANUSCRIPT ACCEPTED BY THE SOCIETY OCTOBER 13, 1993

# HYDROGEOLOGY OF THE SAN LUIS VALLEY, COLORADO

## AN OVERVIEW—AND A LOOK AT THE FUTURE

By  
Philip A. Emery  
Al<sub>2</sub>O<sub>3</sub>Geohydrology  
2910 Star Drive  
Lake Havasu City, Arizona 86406

A note from the author—During the period 1966–1980, I was either collecting data, interpreting data, or writing reports regarding the San Luis Valley. Other duties at other locales prevented me from working nearly full time on the valley, as I did from 1966 to 1972. In any case, I devoted considerable time and effort investigating the valley's water resources and, therefore, I am both honored and pleased to author this paper for GSA. The U.S. Geological Survey transferred me to Alamosa 30 years ago when I was appointed Project Chief of a 5-year hydrologic study of the San Luis Valley. I departed Colorado in 1972. I returned to the valley in 1979 to testify in a trial regarding rules and regulations proposed by the Colorado State Engineer, and once again in 1991 to testify in the AWDI trial. Even though the AWDI trial process familiarized me with some post-1979 hydrologic studies, my knowledge of studies conducted during the last 10 to 15 years is somewhat limited. Therefore, I apologize for the somewhat "dated" data, as well as omissions and/or errors in the following overview of the valley's hydrology.

### INTRODUCTION

The San Luis Valley is a large intermontane valley about 100 miles long and 50 miles wide. It occupies an area of approximately 3,200 square miles and has an average altitude of about 7,700 feet. The valley is bounded on the east and west by mountains with some peaks exceeding an altitude of 14,000 feet. Most of the valley floor is bordered by alluvial fans; the most extensive being the Rio Grande fan. The valley floor is a nearly featureless plain except for the San Luis Hills, sand dunes, and playa lakes.

The valley's natural vegetation consists mainly of phreatophytes and xerophytes plus deciduous trees that occur adjacent to the perennial streams. The phreatophytes occupy about 1,100 square miles (more than one-third of the valley floor), and grow in areas where the depth to water below the land surface is 12 feet or less. Rather sparse xerophytes inhabit the slopes of the alluvial fans as well as uncultivated areas bordering the central part of the valley. The area covered by xerophytes and short range grass is about 1,000 mi<sup>2</sup>.

Most of the streamflow is derived from snowmelt from about 4,700 mi<sup>2</sup> of watershed in the surrounding mountains. The northern part of the valley is internally drained and is referred to as the "closed basin". The lowest part of the closed basin is known locally as the "sump". The southern part of the valley is drained by the Rio Grande and its major tributary the Conejos River.

The climate of the San Luis Valley is arid and is characterized by cold winters, moderate summers, and much sunshine. The average annual precipitation is about 7.5 inches and potential evapotranspiration exceeds 40 inches. Average annual temperature is about 42°F, with extremes of -50°F and 91°F. Due to the short growing season (90–120 days), crops are restricted mainly to barley, oats, hay, potatoes, and other vegetables. These crops are cultivated and irrigated in an area comprising about 1,000 mi<sup>2</sup>.

The San Luis Valley has been occupied and utilized for a rather long time span. Folsom campsites (ca. 10,900–10,300 yr. B.P.) located near playa lakes, have been described by Jodry and others (1989). Later, the valley was a hunting ground for Indians including the Ute and Jicarilla Apache tribes. Spanish settlers first entered the valley between 1630 and 1640. For about 250 years the valley was utilized for rather limited farming, cattle grazing, and hunting. The cultivation of crops was not very extensive until the 1890's. Artesian water was discovered about 1887, and within four years, approximately 2,000 flowing wells had been developed. By 1904, there were more than 3,200 flowing wells, and by 1916, it was estimated there were 5,000. The author reported that by 1980 there were nearly 7,700 wells withdrawing water from the confined (artesian) aquifer. In addition, there were about 2,300 pumped wells in the unconfined aquifer.

The extensive development of the valley's aquifers concurrent with development of a large surface-water irrigation system has created a number of hydrologic and legal problems. Some areas of the valley are waterlogged due to inadequate drainage, and large amounts of water are consumed by nonbeneficial evapotranspiration. The proper conjunctive use of ground water and surface water has been, and will continue to be, of prime importance to the management of the valley's water resources.

## GEOLOGY

The San Luis Valley is a north-trending structural depression downfaulted on the eastern border and hinged on the western side. The valley is underlain by as much as 12,000 feet of clay, silt, sand, gravel, and interbedded volcanic flows and tuffs. The alluvial deposits are coarse and permeable near the bordering mountains and grade to fine-grained, less permeable deposits toward the center of the valley. Lenticular clay beds of probable lacustrine origin form a "clay series" that occurs throughout much of the central and northern parts of the valley at depths ranging from 20 to 120 feet below the land surface. Lenticular clays exist throughout the valley fill at varying depths, but the clay series probably represents the most laterally persistent and identifiable sequence of clay beds.

Data obtained from geophysical surveys and oil test holes indicate the valley-fill deposits overlie relatively impermeable crystalline rock, which has been faulted into a north-trending series of en echelon horsts and grabens.

The bordering Sangre de Cristo Mountains on the east are composed of igneous, metamorphic, and sedimentary rocks, whereas the San Juan Mountains on the west consist mainly of volcanic flows, tuffs and breccias. Many of the lava flows and tuffs from the San Juans dip generally eastward under the valley floor where they are incorporated in the valley-fill deposits.

## WATER BUDGET

About 2,800,000 acre-feet of water enter and leave the San Luis Valley each year. Table 1 is a generalized water budget for the valley.

The most important source of water to the valley is surface-water inflow. It provides, directly or indirectly, nearly all the water used for irrigation. Not only is the surface water applied directly to the irrigated land, but it also supplies most of the recharge to the valley's aquifers. Precipitation on the valley floor, which results mainly from low intensity storms, can be considered only a small part of the water supply and serves only as a supplemental source for irrigation and ground-water recharge. Ground-water inflow is not included in table 1 due to its small magnitude.

**Table 1.** Generalized annual water budget for San Luis Valley (1924-1969)

[All values in acre-feet/yr]

WATER IN		WATER OUT	
Precipitation	1,220,000	Evapotranspiration	2,420,000
Surface water inflow	1,580,000	Surface-water outflow	330,000
Ground-water inflow	50,000	Ground-water outflow	50,000
<b>TOTAL</b>	<b>2,800,000</b>	<b>TOTAL</b>	<b>2,800,000</b>

annual surface-water inflow to the valley averages 1,580,000 acre-ft. However, it can vary considerably. For example, it ranged from a low of 743,000 acre-ft in 1951 to a high of 2,783,000 acre-ft in 1941.

A large percentage of the annual surface-water inflow occurs during the snowmelt runoff period (April-June). On the Rio Grande, for example, more than 70 percent of the annual inflow occurs between April 1 and July 30. After the snowmelt runoff, streamflow declines during the summer with minor fluctuations caused by precipitation.

## GROUND WATER

Ground water occurs in both unconfined and confined aquifers in the San Luis Valley. Although the rock materials making up these aquifers are similar, their storage characteristics and head responses to stress are quite different.

Artesian, or confined conditions, are created over most of the valley's artesian basin by clay layers referred to by local well drillers as "blue clay" and by Emery and others (1971) as the "clay series". In the southwestern part of the valley, the clay series overlaps northeastward-dipping lava flows. In this area, the uppermost lava flow is the principal confining unit, even though confined conditions exist locally between the lava flow and overlying clay units.

The aquifers are recharged by infiltration of applied irrigation water, canal leakage, seepage from mountain streams that flow across the permeable alluvial fans, and infiltration of precipitation. The major discharge from the unconfined aquifer is by pumping wells, seepage to streams, and evapotranspiration. Discharge from the confined aquifer is by wells, springs, and upward leakage through the clay series into the unconfined aquifer.

## Water in the Unconfined Aquifer

Unconfined ground water occurs nearly everywhere in the valley. The depth to water below the land surface is 12 feet or less over about one-half of the valley. However, in parts of the southern San Luis Valley, the depth to water exceeds 300 feet. Because of abundant recharge from surface water, little long-term fluctuation in the water table has occurred. The unconfined aquifer is the principal source of ground water for irrigation, supplying 80 percent of all large capacity (yield more than 300 gpm) wells.

SAN LUIS VALLEY

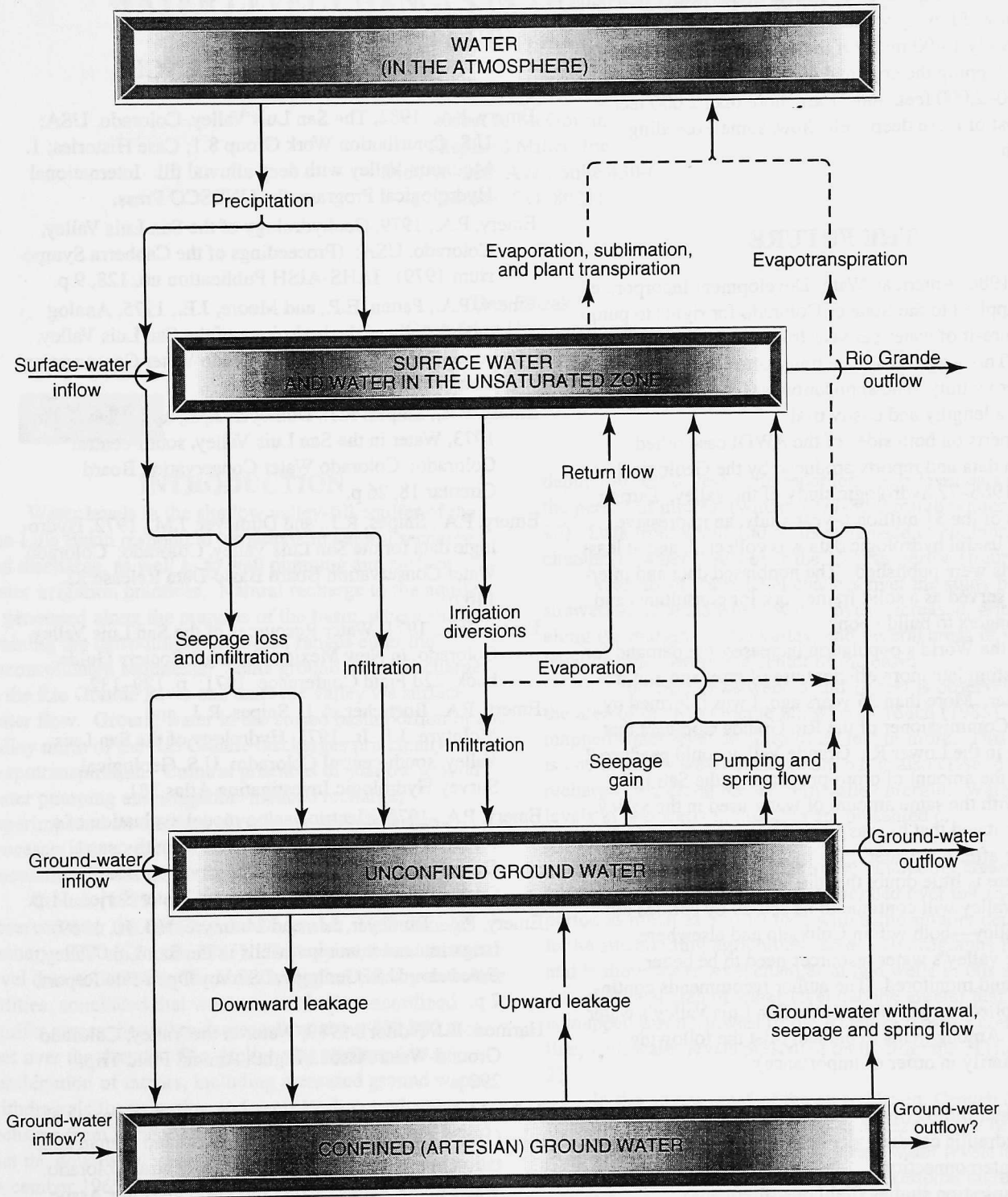

Generalized hydrologic flow diagram of San Luis Valley

## Water in the Confined Aquifer

Confined ground water occurs under nearly one-half of the valley. Flowing wells can be obtained in an area of approximately 1,400 mi<sup>2</sup>. Of the 650 large-capacity irrigation wells tapping the confined aquifer, 99 range in depth from 1,000–2,000 feet, and 21 are more than 2,000 feet deep. Most of these deep wells flow, some exceeding 3,000 gpm.

## THE FUTURE

In 1986, American Water Development Incorporated (AWDI) applied to the State of Colorado for rights to pump 200,000 acre-ft of water per year from the San Luis Valley's aquifers. This water was to be transported via pipeline to the Denver vicinity. The application was dismissed in 1991, following a lengthy and costly trial.

Experts on both sides of the AWDI case relied heavily on data and reports produced by the Geological Survey's 1966–72 hydrologic study of the valley. During the course of the \$1 million 6-year study, an impressive amount of useful hydrologic data was collected, and at least nine reports were published. The nonbiased data and interpretations served as a solid framework for consultants and water managers to build upon.

As the World's population increases, the demand for food will stimulate more efficient use of cropland and irrigation water. More than 25 years ago, I was informed by the Texas Commissioner of the Rio Grande Compact that the people in the Lower Rio Grande Valley could produce 2 to 3 times the amount of crops produced in the San Luis Valley—with the same amount of water used in the valley. He further stated that he was going to spend the rest of his life "going after that water".

There is little doubt that the water resources of the San Luis Valley will continue to be sought by entities outside the valley—both within Colorado and elsewhere.

The valley's water resources need to be better described and monitored. The author recommends continued data collection and study of the San Luis Valley's water resources. Among items to pursue, I list the following: (not necessarily in order of importance):

- Surface-water inflow (more rim-inflow gaging stations)
- Vertical hydraulic conductivity determinations (aquifer interconnection)
- Evapotranspiration studies (field measurements)
- Land subsidence monitoring (subsidence monitoring wells, etc.)
- Aquifer storage coefficients (aquifer tests, etc.)
- Confined & unconfined aquifer head measurements (continue and expand)
- Quality of ground- and surface-water monitoring and studies

Stream-aquifer connection

Ground-water withdrawal and consumptive use

## SELECTED REFERENCES

- Emery, P.A., 1982, The San Luis Valley, Colorado, USA: U.S. Contribution Work Group 8.1; Case Histories; 1. Mountain Valley with deep alluvial fill. International Hydrological Program, the UNESCO Press.
- Emery, P.A., 1979, Geohydrology of the San Luis Valley, Colorado, USA: (Proceedings of the Canberra Symposium 1979): IAHS-AISH Publication no. 128, 9 p.
- Emery, P.A., Patten, E.P., and Moore, J.E., 1975, Analog model study of the hydrology of the San Luis Valley, south-central Colorado: Colorado Water Conservation Board Circular 29, 21 p.
- Emery, P.A., Snipes, R.J., Dumeyer, J.M., and Klein, J.M., 1973, Water in the San Luis Valley, south-central Colorado: Colorado Water Conservation Board Circular 18, 26 p.
- Emery, P.A., Snipes, R.J., and Dumeyer, J.M., 1972, Hydrologic data for the San Luis Valley, Colorado: Colorado Water Conservation Board Basic-Data Release 22, 146 p.
- Emery, P.A., 1971, Water Resources of the San Luis Valley, Colorado, in New Mexico Geologic Society Guidebook, 22d Field Conference, 1971: p. 129–132.
- Emery, P.A., Boettcher, A.J., Snipes, R.J., and McIntyre, J.J., Jr., 1971, Hydrology of the San Luis Valley, south-central Colorado: U.S. Geological Survey Hydrologic Investigation Atlas 381.
- Emery, P.A., 1970, Electric analog model evaluation of a water-salvage plan, San Luis Valley, south-central Colorado: Colorado Water Conservation Board Ground-Water Circular 14, Ground Water Series, 11 p.
- Emery, P.A., Dumeyer, J.J., and McIntyre, H.J. Jr., 1969, Irrigation and municipal wells in the San Luis Valley, Colorado: U.S. Geological Survey Open-File Report, 7 p.
- Harmon, E.J. (editor), 1989, Water in the Valley, Colorado Ground-Water Assoc., Eighth Annual Field Trip, 292 p.
- Jodry, M.A., Shafer, D.S., Stanford, D.J., and Daves, O.K. (1989), Late Quaternary environment and human adaptation in the San Luis Valley, south-central Colorado. Water in the Valley: Colorado Ground-Water Assoc., Eighth Annual Field Trip, pp. 189–208.
- Powell, W.J. (1958), Ground-water resources of the San Luis Valley, Colorado: U.S. Geological Survey Water-Supply Paper 1379.
- Siebenthal, C.E. (1910), Geology and water resources of the San Luis Valley, Colorado: U.S. Geological Survey Water-Supply Paper 240.

# WATER LEVEL CHANGES IN THE UNCONFINED AQUIFER OF THE SAN LUIS VALLEY, 1980-1995

By

Isobel R. McGowan  
Shepherd Miller, Inc.  
2460 W. 26th Ave., Suite 430-C  
Denver, CO 80211

and

Dan Plazak  
Consulting Hydrogeologist  
4592 Everett Street  
Wheat Ridge, CO 80033



## INTRODUCTION

Water levels in the shallow valley-fill aquifer of the San Luis Basin respond to variations in natural recharge and discharge, as well as to well pumping and surface water irrigation practices. Natural recharge to the aquifer is generated along the margins of the basin, where streams draining the surrounding mountain ranges enter the unconsolidated sediments. Some ground water discharges to the Rio Grande River and exits the valley via surface water flow. Ground water in the closed basin portion of the valley north of the Rio Grande discharges principally via evapotranspiration. Cultural practices of shallow ground water pumping and irrigation-induced recharge, superimposed on the natural recharge and discharge processes, have resulted in distinct patterns of water level fluctuations in the unconfined aquifer.

Crouch (1985) described the changes in water levels observed over the decade from December, 1969 through January, 1980 (Crouch, 1985). That report, based on water level data collected by the U.S. Geological Survey and other entities, concluded that water stored in the unconfined aquifer across the valley decreased by about 880,000 acre-feet over the decade. The decline was attributed to a combination of factors, including increased ground water withdrawals for irrigation and decreased ground water recharge from surface water diversions. The author noted that the downward water level trend observed from December 1969 to January 1980 would not necessarily continue, as changing climate or irrigation practices could result in trends different from those measured during the study period.

## 1980-95 WATER LEVEL CHANGES

Water level data were collected from the USGS electronic database (WATSTORE) for all wells with total

depth 100 feet or less, with recorded water level data over the period of interest (winter 1979-80 through winter 1994-95). Data from about 100 wells were used to contour changes in water levels over the 15-year period (figure 1).

Analysis of water level changes over the study period showed some areas where water levels increased, primarily along the margins of the valley, and several areas of water level decline toward the center of the basin.

An increase of between 5 and 10 feet is observed in the area of the Rio Grande fan where Crouch (1985) mapped water level declines of 20 feet or more. This area is one of heavy well development, but is also close to the recharge area along the western valley margin. Water levels in two wells in this area are presented on hydrographs A and C (figure 2).

Toward the center of the valley, including areas near Hooper and Mosca, water levels declined over the 15-year period as much as 5 to 10 feet, with some smaller declines in the surrounding agricultural areas. Hydrographs B, D, and E show water level changes in two wells in this area. An additional area of water level decline greater than 5 feet is mapped just northwest of the Alamosa/Costilla county line, with water levels presented on hydrograph H (figure 2).

In the "sump area" of the closed basin, Crouch (1985) reported water level increases up to 5 feet over the decade of the 70s. In the subsequent 15 years, water levels have continued to rise in some wells, with additional increases over 5 feet in some places (hydrographs F and G, figure 2).

In the area south of Trincher Creek, Crouch mapped water level declines greater than 20 feet. Unfortunately, water level data retrieved from the WATSTORE system did not include any wells in this area monitored 1980 to 1995;

LEGEND

[Hatched Box] > 5' DRAWDOWN

[Star Symbol] F\* HYDROGRAPHS PRESENTED ON FIGURE 2

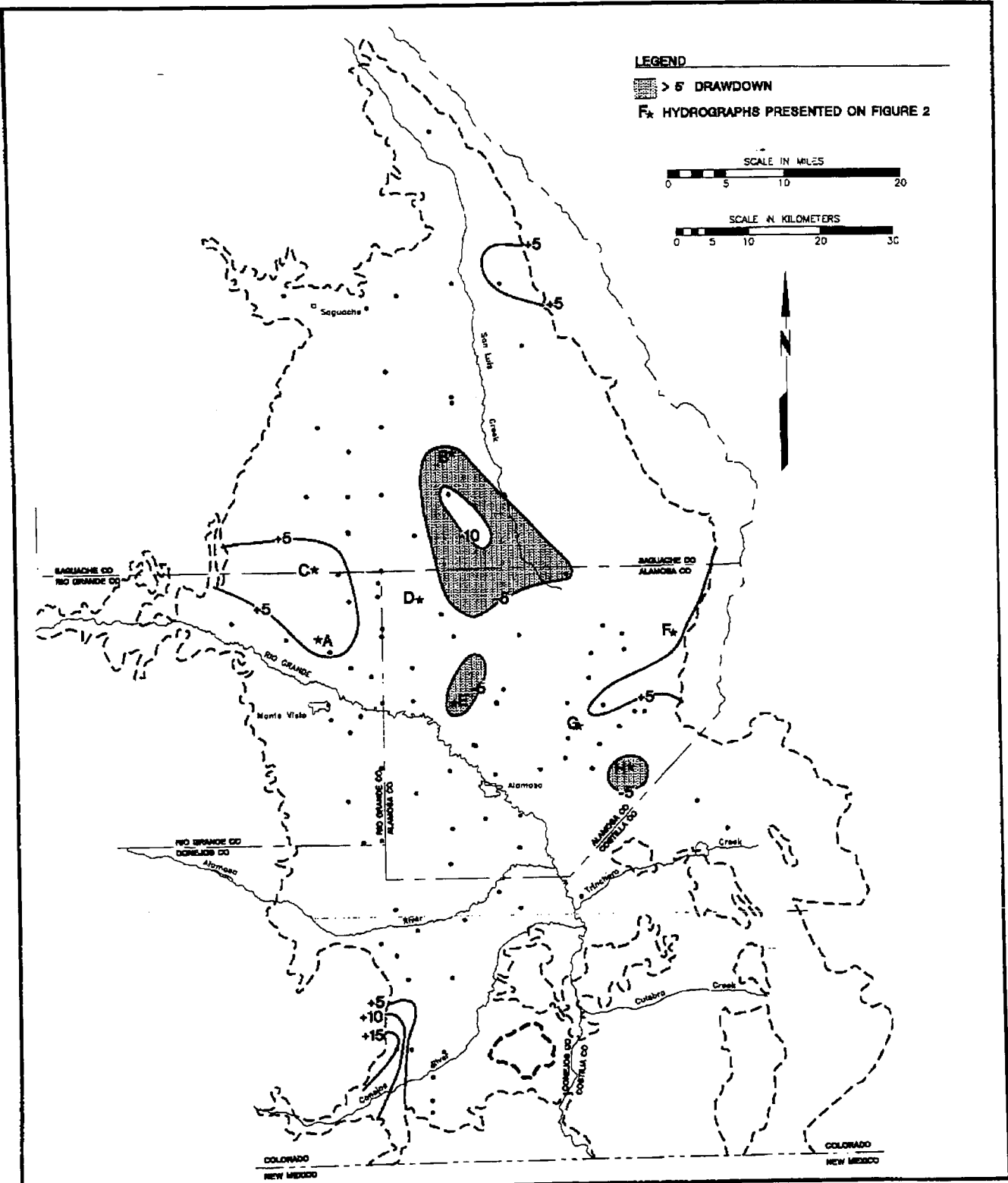
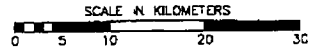
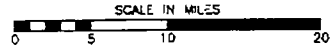
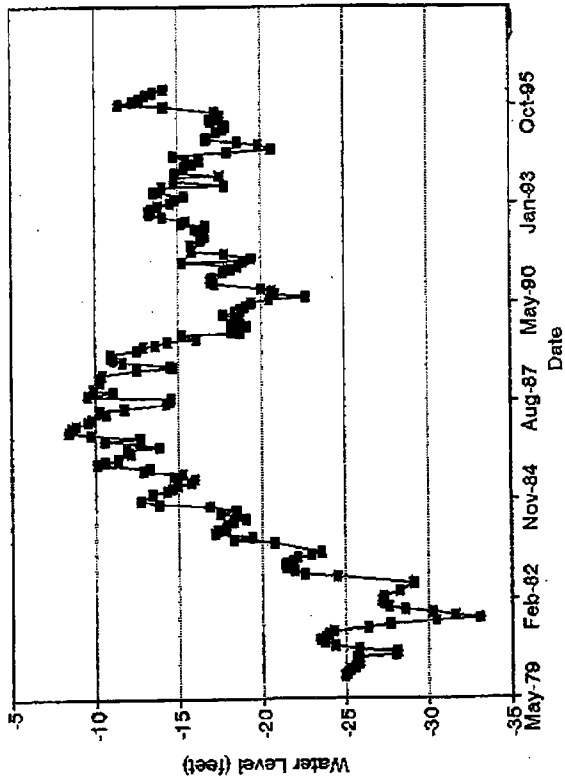

FIGURE 1  
UNCONFINED AQUIFER WATER  
LEVEL CHANGES 1980-1995

Date: JUNE 1996  
Project: 81-905  
File: BASE

A



B

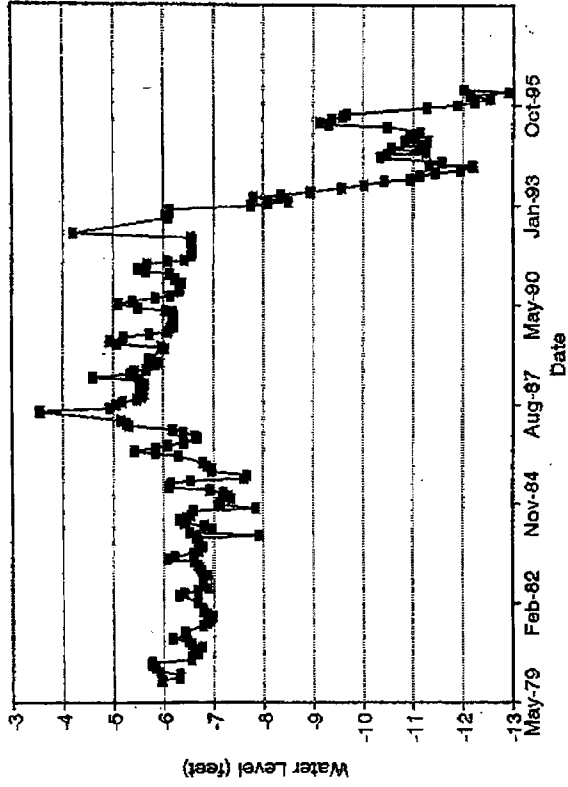

C

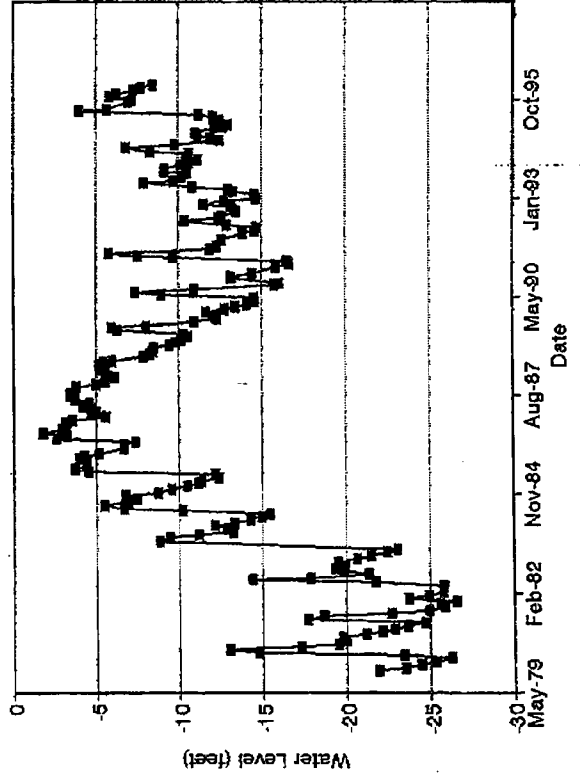

D

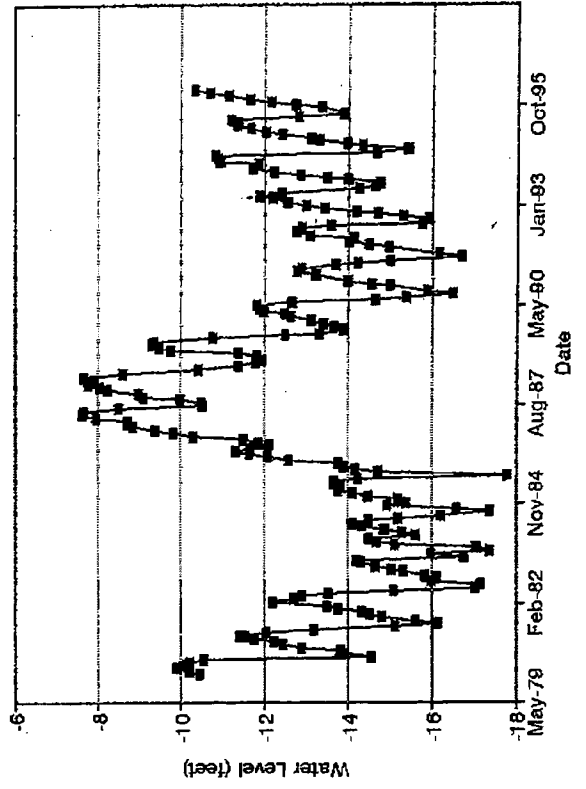

Figure 2. Well Hydrographs

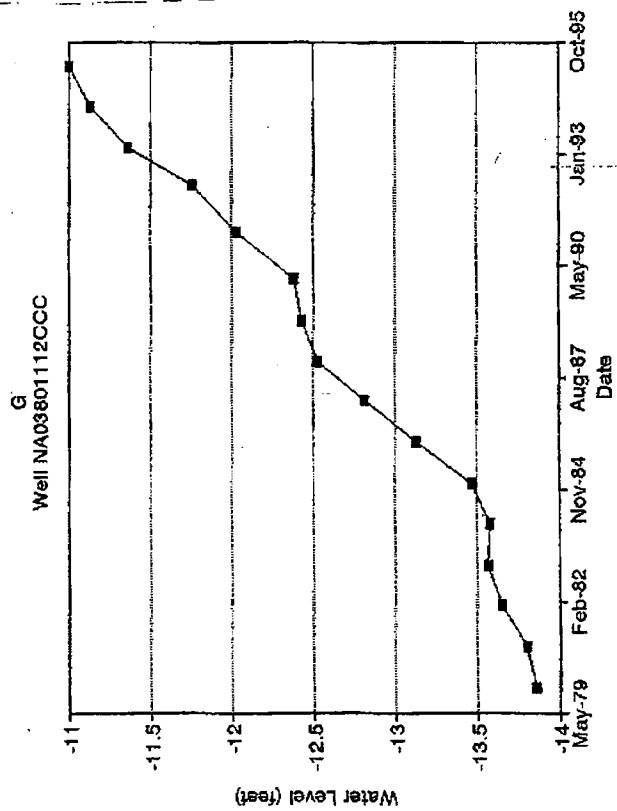
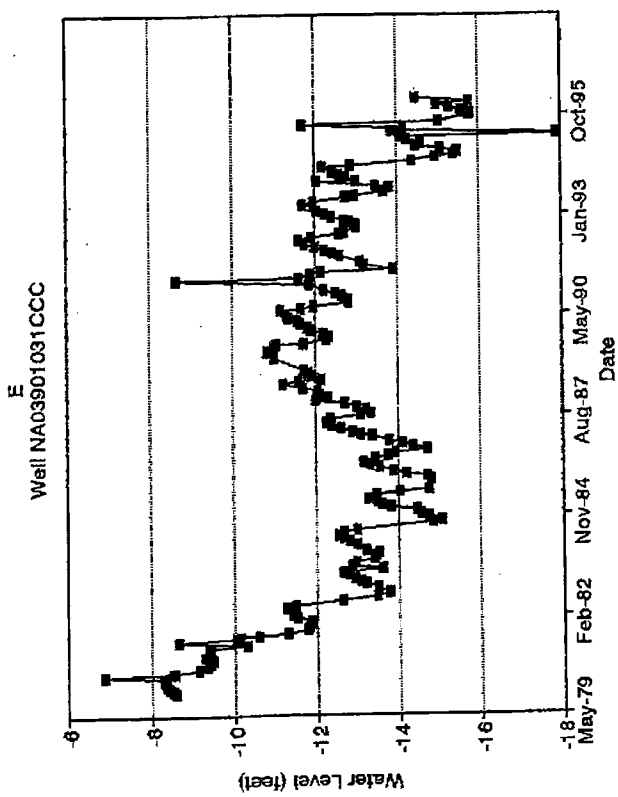
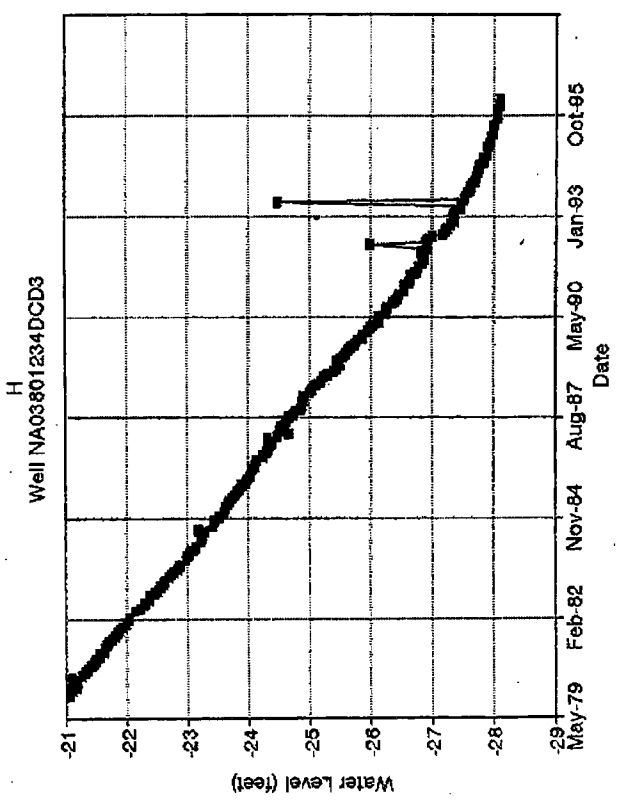
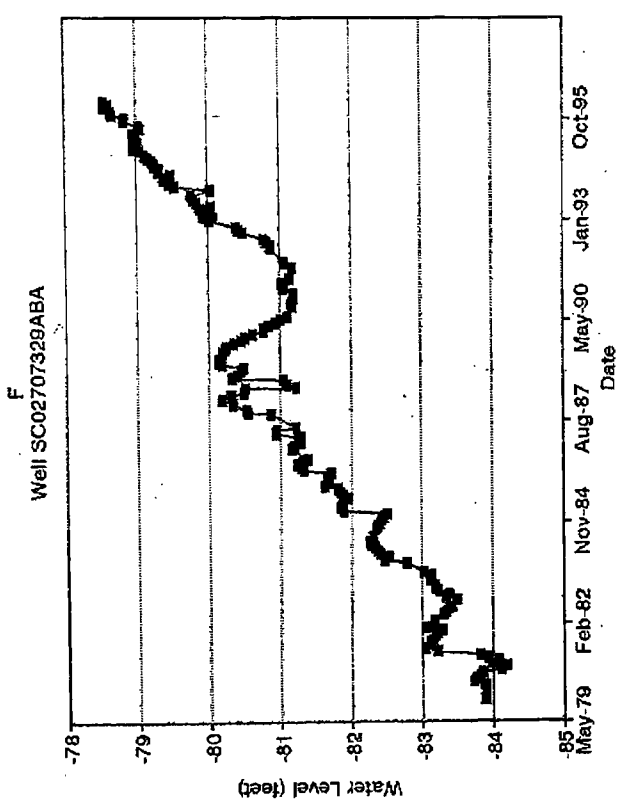

Figure 2. Well Hydrographs, Continued

therefore, we are unable to comment on the ongoing water level trends in this area.

## GROUND WATER RECHARGE

Two indicators of available ground water recharge were considered to aid in interpretation of ground water level trends observed over the study period. These indicators are:

- Rio Grande River streamflow at Del Norte, Colorado
- precipitation at Alamosa, Colorado.

Figures 3 and 4 show how these two indicators have varied through time.

Over the period studied by Crouch (1985), streamflow in the Rio Grande was about 4 percent below the long-term (1950 to present) average, and precipitation at Alamosa was about 2.5 percent below average. Over the 1980-95 study period, streamflow on the Rio Grande was about 12 percent above the long-term average, and precipitation at Alamosa was less than 1 percent below average. The 1980 through 1995 period included several years of very high runoff in the mid-1980s, most notably 1985, 1986, and 1987.

## WATER LEVEL TRENDS

Water levels near the basin margins are strongly affected by annual recharge events and by year-to-year changes in runoff from the surrounding mountains (hydrographs A through D, figure 2). Conversely, ground water levels in the valley center experience little seasonal change, and were not strongly affected by the high or low runoff periods.

In areas where extensive ground water pumping occurs, ground water levels are expected to decline during periods of average recharge, due to ground water withdrawal from storage. During periods when ground water recharge is below average, the decline in water levels is expected to be steeper; conversely, when ground

water recharge is above average, some recovery (or a lower rate of decline) in water levels is predicted. Therefore, in the areas of well development in the unconfined aquifer, declining levels would be predicted from 1969 through 1981 (an average-recharge period immediately preceded by a very wet year), rising levels (or smaller declines) 1984 through 1987 (an above-average recharge period), and falling levels from 1988 through 1995 (an average to below-average recharge period). These patterns are observed in many hydrographs (Crouch, 1985; figure 2). For example, where Crouch mapped water level declines greater than 20 feet over the decade of the 1970s, a net 5 to 10 foot recovery was mapped over the subsequent 15-year period. During that period, water levels recovered during the wet period of the late 80s, and declined again in the early 90s. Another observed trend is rising water levels in the sump area. Water levels in this area have risen steadily over the past 25 years, through both wet and dry periods. (hydrographs G and F, figure 2).

## SUMMARY

The unconfined aquifer is affected by natural recharge along the valley margins, but also reflects the influences of well pumping and recharge by surface water irrigation practices. Water level declines and recoveries are somewhat predictable based on indicators of available recharge, but cultural practices have clearly left their mark on aquifer conditions.

## REFERENCE

Crouch, Thomas M. 1985. Potentiometric Surface, 1980, and Water-Level Changes, 1969-80, in the Unconfined Valley-Fill Aquifers of the San Luis Basin, Colorado and New Mexico. U.S. Geological Survey Hydrologic Atlas HA-683.

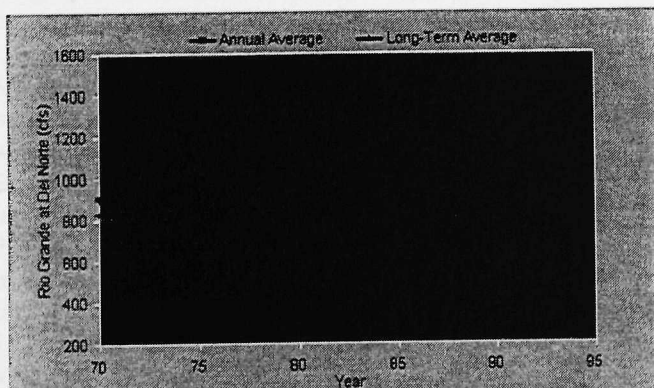

Figure 3. Rio Grande Flow at Del Norte

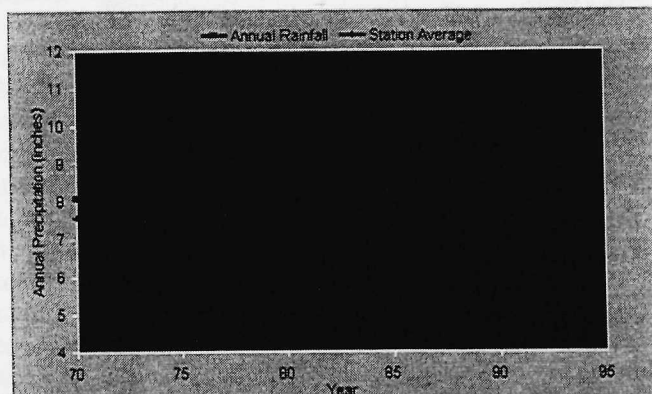

Figure 4. Precipitation at Alamosa, CO

# EVIDENCE SUPPORTING ENHANCED UPWARD GROUND WATER FLOW IN THE SAN LUIS VALLEY, COLORADO

By

Charles E. Stanzione

Ground Water Geologist, Associate

Bishop-Brogden Associates, Inc.

165 South Union Boulevard, Suite 670

Lakewood, CO 80228



## INTRODUCTION

This study summarizes supporting evidence for the upward flow of ground water in the San Luis Valley (Valley) and suggests this flow may be enhanced along the prominent geologic faults and fault zones in the Valley. The information for this study was obtained from state and federal agencies, private investigators, and university sources. The information included: downhole spinner test data; United States Geological Survey (USGS) technical reports and water resource literature; Colorado Department of Water Resources records and reports; geologic and hydrologic reports by private investigators; reports and theses available from universities; and analyses of pump test data obtained from shallow Closed Basin Project (CBP) wells. Based on the results of this study, further research is suggested for the analysis of aquifer parameters associated with the faults and fault zones, and for the quantitative analysis of upward ground water flow discharged to streams and consumed by evapotranspiration.

## BACKGROUND

The San Luis Valley (Valley) is an intermontane basin located in south-central Colorado, as shown in Figure 1. The Valley covers an area of approximately 3200 square miles and is bordered by the Sangre de Cristo Mountains on the northeast-east, the San Juan Mountains on the northwest-west, and expands to the south into northern New Mexico, following the Rio Grande Rift structure. The Valley has a complex hydrologic system, including a multi-layered confined aquifer system and a shallow unconfined aquifer system, and numerous surface water features, the largest of which is the Rio Grande. In addition to the natural hydrologic features, the Valley includes many man-made structures (canals, ditches, drains, water wells) used for the extensive development of surface and ground water resources for irrigation purposes. Numerous investigators have completed research on the water resources of the Valley, including detailed studies of the geology and hydrology of the Valley, and as a result, abundant data are

available in the public record.

The faulting in the Valley is associated with the structural geologic setting of regional orogenic processes and the Rio Grande Rift. The Valley structure is generally characterized by a horst in the central-valley area, near the town of Alamosa, and grabens along the east and west valley laterals, as shown in Figure 2. Numerous faults have been mapped by the USGS (Tweto, 1979) and identified by analysis of satellite imagery (Earth Satellite Corporation, 1986-1988, and CWRPDA-HRS Water Consultants, Inc., 1987) and interpretation of seismic data (Gries, 1985). The USGS and other investigators have also studied the Valley hydrology in detail by compiling and analyzing surface water and ground water data and modeling the Valley's hydrologic system. These studies have included the analysis of shallow and deep aquifer water levels and the evaluation of the role of faulting in the hydrologic system. These studies and data provide the basis for the general geologic and hydrologic conceptual models of the Valley, shown in Figures 2 and 3, and support the concepts of upward ground water movement in the Valley and enhanced vertical flow along faults and fault zones.

## SUPPORTING EVIDENCE

The literature provides abundant evidence of the upward movement of ground water in the Valley. Water levels in wells completed in portions of the confined aquifer have historically indicated upward vertical ground water gradients; many deep wells flow at the land surface (Powell, 1958 and Emery, 1971). High potentiometric surfaces result from the high elevation head of the recharge zones in the San Juan and Sangre de Cristo Mountains and from changes in aquifer parameters in the confined aquifer. More recent research confirmed that evidence exists to support the occurrence of leakage from the confined aquifer upward into the unconfined system (CWRPDA-HRS Water Consultants, Inc., 1987; Harmon and Hanna, 1989; Leonard and Watts, 1989) based on the results of satellite

Figure 1. Location Map of the San Luis Valley and the Closed Basin Division.

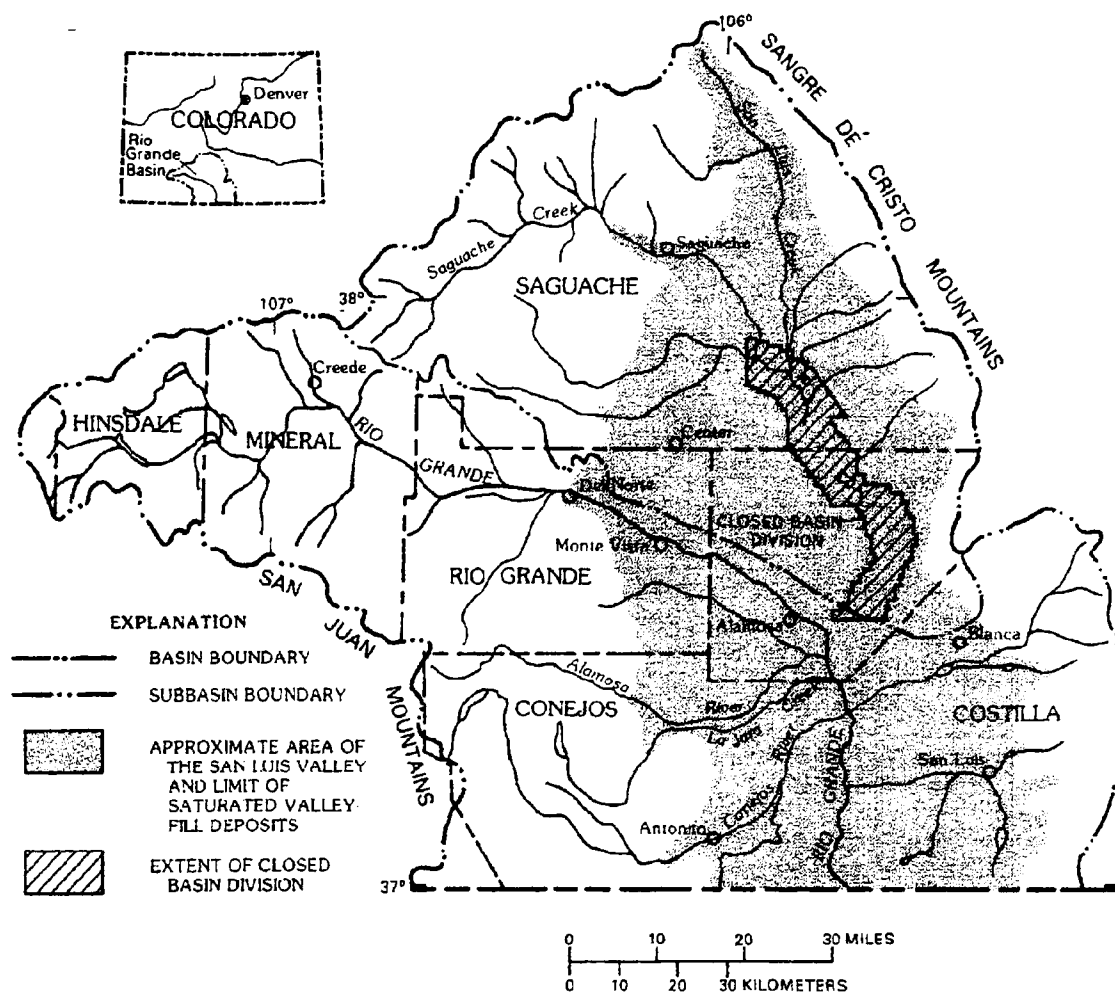

Reprinted from U.S. Geological Survey WRI Report 87-4284.

imagery evaluation, water quality analyses, and temperature gradient analyses.

The occurrence of faulting and fault zones in the Valley is also well documented and has been commonly incorporated into computer models of the Valley ground water system. Structural mapping (Tweto, 1979 and Burroughs, 1981) indicates faulting in the Valley, particularly in the central area. Satellite imagery and seismic line data also confirm the presence of faulting and fault zones in the central portion of the Valley (Earth Satellite Corporation, 1986-1988; CWRPDA-HRS Water Consultants, Inc., 1987; Gries, 1985; and Harmon and Hanna, 1989). Figure 4 presents the general locations of faults in the central part of the Valley (Harmon and Hanna, 1989). Recent research on faulting of shallow, unconsolidated materials (Wyatt and others, 1996), confirms the potential for faults to penetrate shallow sediments and potentially act as zones of enhanced

ground water flow.

The CWRPDA report included detailed discussion on the enhanced upward flow of ground water along the faults, based primarily on interpretation of satellite imagery, water quality analyses, and the results of a spinner log test. Due to the extensional origin of most of the fault structures, the hydraulic conductivity of the fault plane zone appears to be increased. The water quality data, which indicate deteriorated quality at depth in the confined aquifer, suggest that the water quality of the shallow aquifer is also deteriorated in the vicinity of faults and fault zones due to the enhanced upward leakage of poor quality water from the deep confined aquifer along the fault plan (Giles, 1986). The faults and fault zones act as conduits for vertical flow, and as a result, allow ground water to move more easily upward into the shallow system than in their absence.

**Figure 2. Generalized Geologic Cross Section of the San Luis Valley, Colorado**

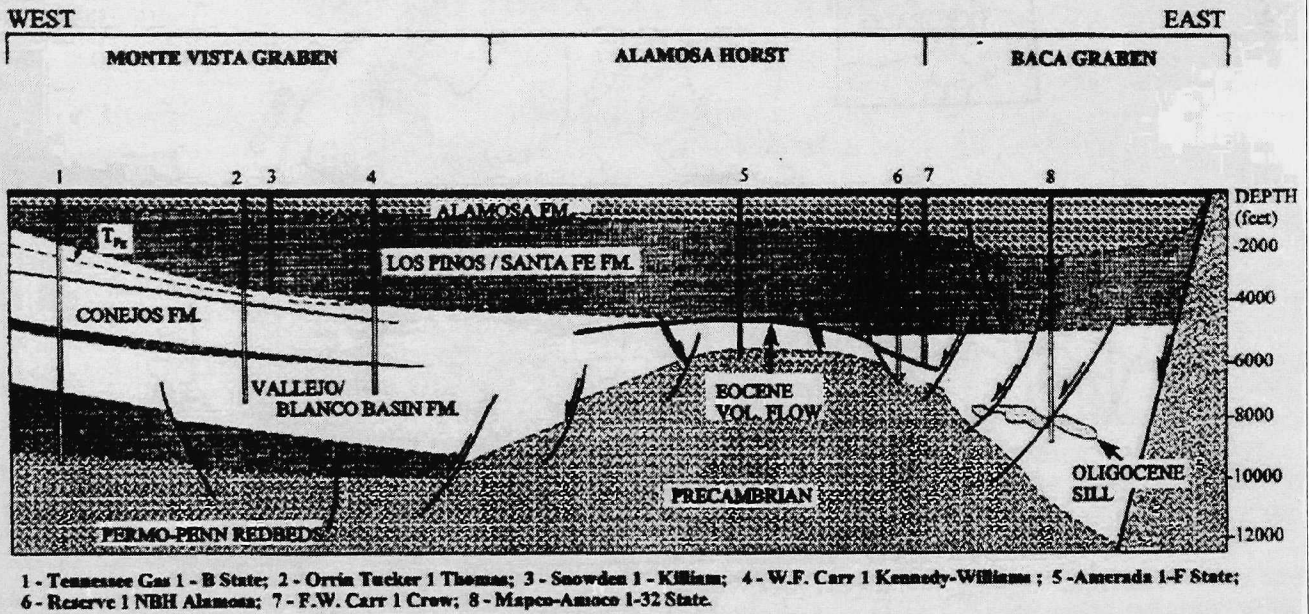

**Figure 3. General Hydrologic Flow Patterns in the San Luis Valley**

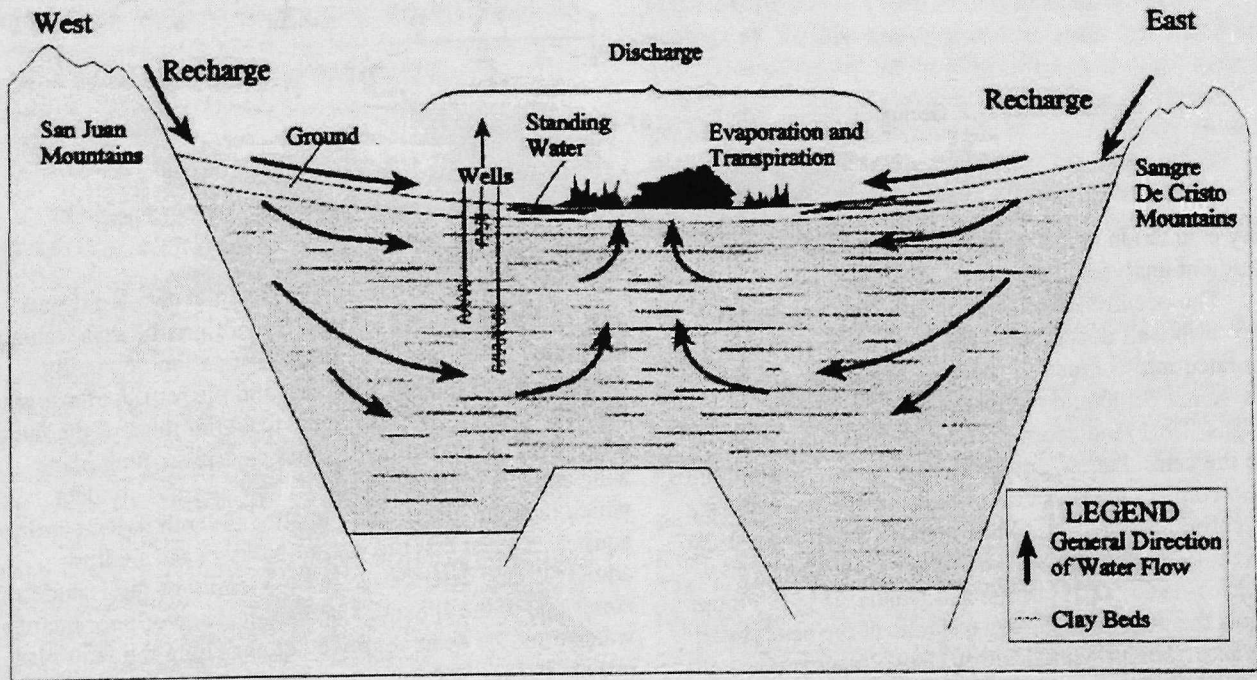
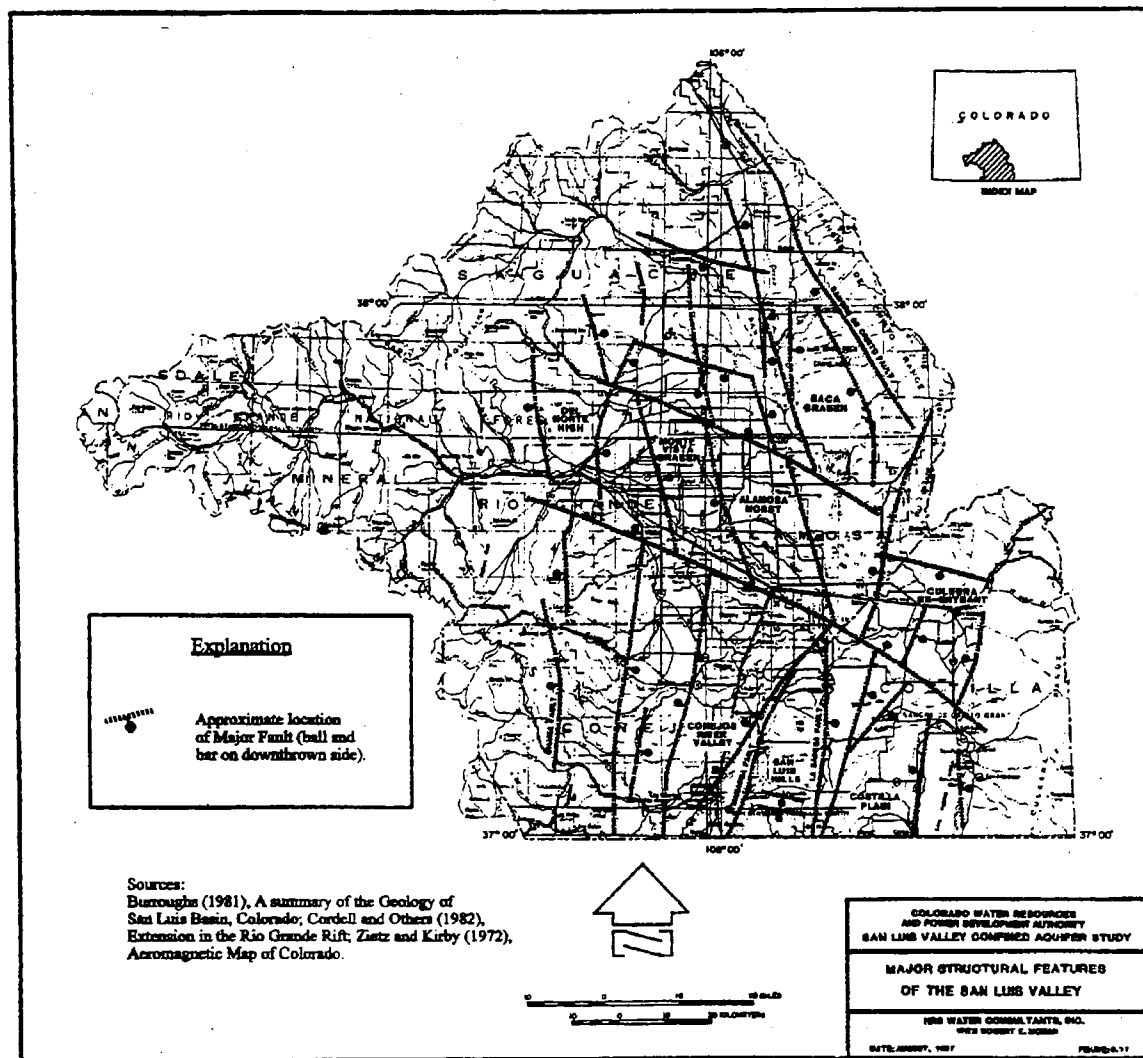
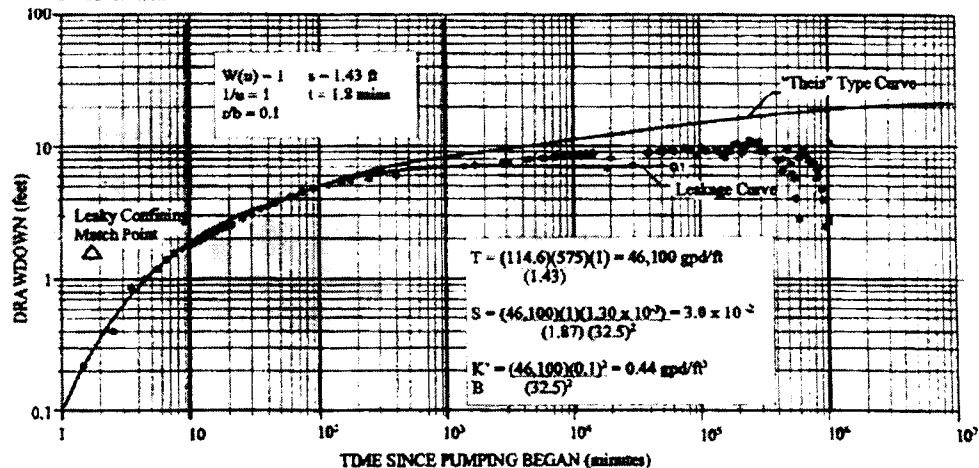

Figure 4. Major Faults of the San Luis Valley



Reprinted courtesy of Colorado Ground Water Association (Hanna and Harmon).

Figure 5. Drawdown vs. Time Plot, 3-Year Test Pumping Well TW3-1, Obs. Well 30W3, LOC. 40-11-89 aca



Analyses of pump test data from 20 CBP wells completed in the shallow unconfined aquifer also support the occurrence of upward leakage and enhanced flow along the fault zones. The data indicate the presence of significant leakage, for which the primary source would be the underlying confined aquifer. This effect is particularly indicated in the data from Well TW3-1, as shown in Figure 5. The test period for this well lasted about three years, and the data reflect the effects of leakage contributing to the aquifer system. The CBP wells are located in a recognized fault zone area and appear to be affected by the enhanced upward flow in the fault zone.

### MODEL APPROACHES

The Valley hydrologic system has been modeled numerous times for research purposes (USGS, 1970, 1975, 1988, 1989; Kolm, 1995) and for analysis of water rights cases (Bishop-Brogden Associates, Inc.; Colorado Department of Water Resources, 1991). Most of these efforts modeled faults as conduits for ground water flow with enhanced vertical hydraulic conductivity. Emery (USGS, 1975) modeled a single fault in the vicinity of Manassa, Colorado with the vertical hydraulic conductivity equal to the horizontal conductivity (ratio of 1 to 1), indicating enhanced vertical flow at the fault location. Hearne also modeled faults with increased vertical hydraulic conductivities; with a ratio of horizontal to vertical conductivity of 1 to 1, as summarized in Table 1.

**Table 1. Summary of Fault Zone Hydraulic Conductivity Ratios Utilized in Computer Models of the San Luis Valley, Colorado**

<u>Model</u>	<u>Fault Zone Horizontal to Vertical Hydraulic Conductivity Ratio</u>
Emery, 1975	1 to 1
Hearne and Others, 1988	1 to 1
Leonard and Watts, 1989	Variable (1 to 1)
BBA, 1991	10 to 1
SEO, 1991	Variable (1 to 10)

The representation of faults as conduits for enhanced vertical ground water flow plays an important role in the modeling results, due to the amount of water available in the confined aquifer system. As a source of water for the shallow system, the upward movement of water impacts the analysis of the quantity of ground water potentially discharged to stream systems and consumed by evapotranspiration.

### SUGGESTED RESEARCH

The basis for the aquifer parameters representing the flow conditions of the faulted areas is predominantly inferred from available data. Little data are available to determine the vertical hydraulic conductivity of the faulted areas, due to the small number of deep wells completed in these areas and the lack of control on well completion and testing needed to identify actual movement along a fault plane. The available data from the CBP wells provide limited information for the determination of specific leakage factors, and may be an area for further research, including additional testing and analysis of aquifer properties. Deep well drilling and testing in the fault zones would also provide valuable data for analysis of lithologic samples and the determination of specific aquifer properties, particularly if standard pump testing techniques could be combined with advanced logging techniques.

Investigators have used water balance and model approaches to quantify the probable amount of ground water contributed to the shallow aquifer system due to the upward movement of ground water (Emery, 1975; Zorich-Erker, 1980; Huntley, 1976). Based on the available data, the water balance approach is probably the most reliable, but the least specific for flow along an actual fault plane. The water balance analyses can continue to be refined using new data on stream flows, evapotranspiration potential, and further analysis of the amount of ground water inflows contributed from the San Juan Mountain recharge area.

### REFERENCES

- Burroughs, R.L., 1981, A summary of the geology of the San Luis basin, Colorado - New Mexico, with emphasis on the geothermal potential for the Monte Vista graben: Denver, Colorado, U.S. Geological Survey Special Publication 17, 30 p.
- Earth Satellite Corporation (EarthSat), 1986, Tectonic Interpretation of the San Luis Valley, Colorado. Prepared for American Water Development, Inc.
- Earth Satellite Corporation (EarthSat), 1988, supplement to report, Tectonic Interpretation of the San Luis Valley, Colorado. Prepared for American Water Development, Inc.
- Emery, P.A., Boettcher, A.J., Snipes, R.J., and McIntyre, H.J., 1971, Hydrology of the San Luis Valley, south-central Colorado: U.S. Geological Survey Hydro-logic Investigations Atlas, HA-381, 2 sheets, scale 1:250,000.
- \_\_\_\_\_, Patten, E.P., Jr., and Moore, J.E., 1975, Analog model study of the hydrology of the San Luis Valley, south-central Colorado: Denver, Colo., Colorado Water Conservation Board Ground-Water Circular 29, 21 p.

- \_\_\_\_\_, Snipes, R.J., Dunmeyer, J.M., and Klein, J.M., 1972, Hydrologic data for the San Luis Valley, Colorado: Denver, Colo., Colorado Water Conservation Board Basic Data Release 22, 146 p.
- \_\_\_\_\_, Snipes, R.J., Dunmeyer, J.M., and Klein, J.M. 1973, Water in the San Luis Valley, south-central Colorado: Denver, Colo., Colorado Water Conservation Board Water Resources Circular 18, 26 p.
- Gries, R.R., 1985, Seismic Lines in the San Luis Valley, south-central Colorado, in Gries, R.R., and Dyer, R.C., eds., Seismic exploration of the Rocky Mountain region: Rocky Mountains Association of Geologists and Denver Geophysical Society, p. 267-272.
- Hanna, T.M., and Harmon, E.J., 1989, An overview of the historical, stratigraphic, and structural setting of the aquifer system of the San Luis Valley, in Harmon, E.J., ed., Water in the Valley, A 1989 perspective on water supplies, issues and solutions in the San Luis Valley, Colorado, Colorado Ground Water Association, Field Trip Guidebook, p. 1-34.
- Hearne, G.A., and Dewey, J.D., 1988, Hydrologic analysis of the Rio Grande basin north of Embudo, New Mexico, Colorado and New Mexico, U.S. Geological Survey Water Resources Investigations Report 86-4113, 243 p.
- HRS Water Consultants, Inc., 1989, San Luis Valley Confined Aquifer Study (Phase I) Final Report. Prepared for Colorado Water Resources and Power Development Authority.
- Leonard, G.J., and Watts, K.R., 1989, Hydrogeology and Simulated Effects of Ground-Water Development on an Unconfined Aquifer in the Closed Basin Division, San Luis Valley, Colorado, U.S. Geological Survey Water Resources Investigations Report 87-4284.
- Powell, W.J., 1958, Ground-Water Resources of the San Luis Valley Colorado, Geological Survey Water-Supply Paper 1379.
- Williams, M.D., Kolm, K.E., and Turner, A.K., 1992, Development of a Conceptual and Numerical Model Simulating the Unconfined Alluvial Aquifer System of the Northern San Luis Valley, Colorado Using GIS Data Management and Visualization Techniques, Geographic Information Systems in ground water modeling short course notes, International Ground Water Modeling Center, Colorado School of Mines, Golden, Colorado.
- Wyatt, D.E., Waddell, M.G., and Sexton, G.B., 1996, Geophysics and Shallow Faults in Unconsolidated Sediments, Ground Water, vol. 34, no. 2, 326 p.
- Zorich-Erker Engineering, Inc., 1980, Leakage From Confined Aquifer to Unconfined Aquifer—Closed Basin, San Luis Valley, Colorado. Prepared for Rio Grande Water Users Association.



# SAN LUIS VALLEY PROJECT, CLOSED BASIN DIVISION, Colorado



By  
Alamosa Field Division Staff  
Bureau of Reclamation  
Albuquerque Area Office -Alamosa Field Division  
10900 Hwy 160 E  
Alamosa, CO 81101

## MISSION

*The Mission of the Bureau of Reclamation is to manage, develop, and protect water related resources in an environmentally and economically sound manner in the interest of the American public.*

## Historical Background

Near the end of the 19th century, a series of dry years caused severe water shortages to the farmers along the Rio Grande. These people discovered that the river which had met their needs for over 300 years no longer provided enough water. They looked north to the San Luis Valley and saw a valley-wide system of irrigation canals which industrious Colorado pioneers had just completed. The system diverted much of the water historically flowing further south.

The complaints of the Republic of Mexico were the first to receive attention. In 1898 the Republic of Mexico sued the United States for waters from the Rio Grande. This resulted in the Treaty of 1906 in which the U.S. agreed to deliver a total of 60,000 acre feet of water annually to Mexico. Elephant Butte Reservoir was constructed in 1916 to assist the U.S. in meeting the treaty commitment.

In Texas and New Mexico the water shortage persisted. An injunction on construction of reservoirs on Federal lands combined with threatened lawsuits from downstream water users, hampered further development of reservoirs needed to serve the San Luis Valley. In spite of this the valley water users managed to privately fund and construct five reservoirs between 1910 and 1913. Eight major irrigation drains were constructed in the valley to reclaim some 90,000 acres which were becoming waterlogged. The valley continued to use water.

## The Rio Grande Compact

During this period the states of Texas, New Mexico and Colorado conducted discussions on their respective water rights on the Rio Grande. In 1923 the three states seriously started trying to resolve the issue of an equitable distribution of the waters of the Rio Grande. A temporary compact was drawn up in 1928. On March 18, 1938 the Rio Grande Compact was signed by the commissioners of the three states. It was ratified by the Colorado Legislature on February 21, 1939.

The Rio Grande Compact is a complicated document which attempts to maintain the relationship of annual flows across state boundaries which had developed by the early 20th century. The terms of the Compact are flexible, recognizing annual variations in natural flow and anticipating that new sources of water for the Basin would develop. Colorado has the most difficulty meeting its delivery requirement in years when the river's flow is high. Under the Compact, states can also accumulate a debt or credit.

Colorado began to accumulate a debt after 1949 and it reached an estimated 944,000 acre feet, from 1952 to 1966 due to five large water years which occurred during that time. In 1966, Texas and New Mexico sued Colorado. This suit carried to the United States Supreme Court. In 1968 a stipulation was reached among the three states which, in essence, said that Texas and New Mexico would not proceed with further litigation if Colorado would honor its obligations under the Compact. From 1968 to 1985 the State Engineer strictly enforced the terms that Colorado had to meet to repay its debt and meet its annual

allotment. There is a clause in the compact which provides for elimination of a debt or credit if Elephant Butte Reservoir spills. In June 1985 Colorado's alleged debt of 600,000 acre feet was erased by such a spill. In 1986 and 1987 Elephant Butte spilled again insuring that Colorado's allotment was met.

#### **Authorization**

Public Law 92-514, approved on October 20, 1972, gave the Secretary of the Interior permission to construct, operate, and maintain the San Luis Valley Project, Closed Basin Division. It was later amended by Public Law 96-375-Oct. 3, 1980, Public Law 98-570-Oct. 30, 1984, Public Law 100-516-Oct. 24, 1988. Senate Bill No. 85-Apr. 20, 1989, authorized the Colorado Water Conservation Board to contribute to the cost of construction.

#### **General Description**

The Closed Basin Division is located in south central Colorado in the San Luis Valley in a topographic basin called the Closed Basin. The Closed Basin has a surface area of 2,940 square miles. The San Juan Mountains on the west and the Sangre de Cristo Mountains on the east merge to form the northern boundary of the basin. The San Luis Hills form the south boundary.

#### **Purpose of the Project**

The purpose of the Closed Basin Division project is to salvage unconfined ground water and available surface flows in the Closed Basin that would otherwise be lost to evapotranspiration by salt grass, rabbit brush, greasewood, and other vegetation. The salvaged water is delivered through a 42-mile conveyance channel to the Rio Grande to assist Colorado in meeting its commitment to the States of New Mexico and Texas, under the Rio Grande Compact of 1939, and to assist the United States in meeting its commitment to Mexico under the treaty dated May 21, 1906. The Project also provides for the delivery of water to the Alamosa National Wildlife Refuge and Blanca Wildlife Habitat Area, stabilization of San Luis Lake, recreational

facilities at San Luis Lake, and fish and wildlife enhancement.

### **PROJECT FEATURES**

#### **Salvage Wells**

The 170 water salvage wells constructed constitute the core of the Closed Basin water salvage facilities. Salvage wells range from a depth of 85-110 feet, yield 50-1100 gallons per minute, constructed with stainless steel screens and enclosed in concrete vaults. Well fields were developed in four stages. Groundwater in the Project varies in quality. Therefore, pumped waters are blended to meet the "quality of water" terms of the Rio Grande Compact.

#### **Observation Wells**

A network of 82 observation wells provides water level data for both the confined and unconfined aquifers. This data is used to operate the Project within the drawdown limits prescribed by the authorizing legislation.

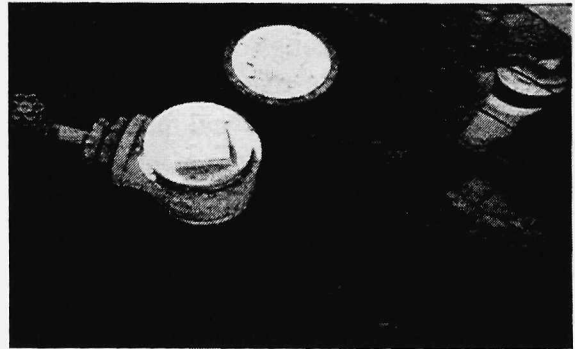

**Figure 1** Observation Well

#### **Pipeline Laterals**

The Project includes approximately 115 miles of pipeline laterals. These laterals transport water from the salvage wells to the conveyance channel in Stages 1 through 4. Stage 5 is a total pipe system, merging with the conveyance channel at the northwest boundary of Stage 4.

### **Conveyance Channel**

The Project conveyance channel provides the means of collecting the salvaged ground water from the pipeline laterals and delivering it to the Rio Grande. The channel is approximately 42 miles long with the design capacity increasing from 45 cfs to a maximum of 160 cfs. Bottom widths range from 8 to 22 feet, and water depths from 3.6 feet to 5.6 feet. The channel is lined with 20 mil thick PVC lining covered with 12-16 inches of aggregate and fill.

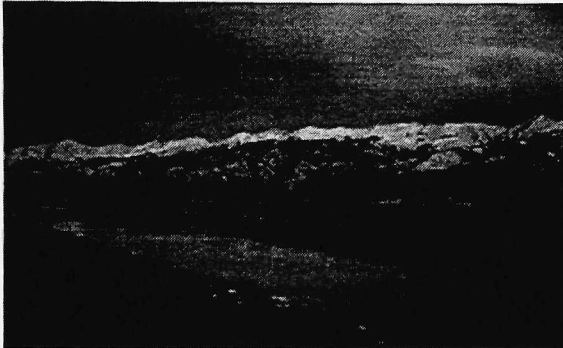

**Figure 2** Conveyance Channel

### **Structures**

Construction of the conveyance channel included two precast concrete siphons, seven check structures, road crossings, four constant head orifice (CHO) turnouts, one Parshall flume, two pumping plants, one feeder canal turnout, and one pipeline turnout. Extensive tree planting called shelter belts have been planted in areas highly susceptible to wind erosion. Drip irrigation systems have been installed to water the tree areas.

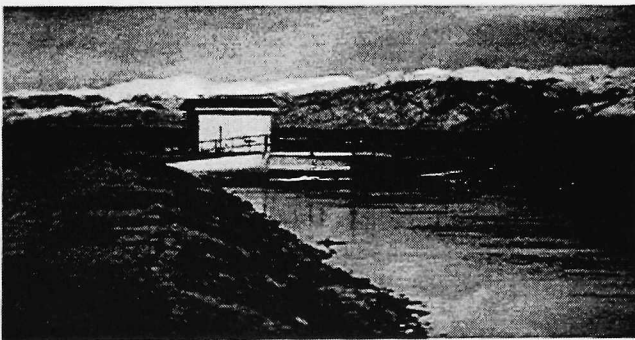

**Figure 3** View of Parshall Flume & Conveyance Channel

### **Programmable Master Supervisor Control System**

A remote control monitoring system to assist with regulating water deliveries, detecting equipment problems, obtaining and storing historical data was installed in 1985. The Programmable Master Supervisory Control (PMSC) system consists of a master station in the Project office, and 280 networked, remote computers used for equipment control and data acquisition.

### **Electrical**

The Project area, which is for the most part remote and inaccessible, is served by two public utility companies. Electrical power is furnished by Public Service Company of Colorado (PSCO) and the San Luis Valley Rural Electric Cooperative (REC). The Project is served by 96 miles of overhead primary line, 31 miles of underground primary line, and 42 miles of underground secondary service. The Project also has a solar-powered pumping system installed at one well site. This stand alone photovoltaic concentrator array pumping system was developed and installed as a joint research project of the Department of Energy and the Bureau of Reclamation.

### **Operation and Maintenance**

The Project is operated and maintained by Bureau of Reclamation personnel. A contract with the Rio Grande Water Conservation District (RGWCD) provides for civil maintenance on Project facilities.

The Project's overall operation is monitored by a three-person operating committee to insure the Project is being operated according to authorizing legislation. This committee consists of members appointed by the Secretary of the Interior, Colorado Water Conservation Board, and Rio Grande Water Conservation District.

### **Recreation Facilities - San Luis State Park**

Recreation facilities were constructed at San Luis Lake through a cooperative effort of the

Bureau of Reclamation, Colorado Water Conservation Board, and the Colorado Division of Wildlife. The area has been designated as a Colorado State Park and administered by the Division of Parks and Recreation with funding provided by the State of Colorado and the Rio Grande Water Conservation District. Facilities include roads, landscaping, fencing, picnic sites, campsites, boat ramps, fishing access areas, sanitary facilities, trails, and water systems.



Figure 4 San Luis Lake Pumping Plant

**PROJECT DATA**  
**CLOSED BASIN DIVISION**  
**SAN LUIS VALLEY PROJECT**

	STAGE 1-2	STAGE 3	STAGE 4	STAGE 5	TOTALS
Yield - Acre Feet per Year	13,350	42,940	34,520	14,020	104,830
Yield - Cubic Feet per Second	18.5	59.4	47.7	19.4	145.0
Number of Salvage Wells	58	45	42	25	170
Range-submersible Pump Horsepower	3 to 15	7.5 - 50	7.5 - 30	5 to 20	---
Salvage Well Yield (Gpm)	90 to 240	200 to 1090	200 to 1120	100 to 620	---
Number - Underdrain Manholes with Pumps	22	--	--	--	22
Miles of Conveyance Channel	21.6	12.6	7.8	--	42
Miles of Pipeline Laterals	32.7	27.2	33.8	21.3	115
Number and Capacity of Pumping Plants	1-19 cfs	1-50 cfs	--	--	---
Miles of Access Roads	78	50	68	41	237
Miles of Electrical Dist. System:					
Overhead Primary	16	26	38	16	96
Underground Primary	10	20	1	-	31
Underground 2ndry	<u>22</u>	<u>4</u>	<u>6</u>	<u>10</u>	<u>42</u>
Total:	48	50	45	26	169
Est. Energy Usage - Kwh per Year	2,814,000	6,259,000	5,640,000	1,950,000	16,663,000
Number of Boundary Observation Wells	30	16	24	12	82
Number of Tree Area Turnouts	8	8	--	--	16

# GEOLOGY OF THE NORTHEASTERN SAN LUIS BASIN, SAGUACHE COUNTY, COLORADO

By  
Thomas A. Watkins  
Lexam Explorations (U.S.A.) Inc.  
P.O. Box 150158  
Lakewood, CO 80215



## INTRODUCTION

The San Luis basin is one of a series of late Oligocene to Pliocene extensional basins that comprise the Rio Grande rift in Colorado, New Mexico and northern Mexico. In general, the basins in Colorado and New Mexico are a series of half-grabens filled with synrift sediments of the Santa Fe Group. The asymmetric nature of the basins is evidenced by reversals in the dip of basin fill sediments. Synrift sediments in the San Luis basin dip to the east. To the north and south, sediments in the Upper Arkansas and Espanola basins dip to the west (Chapin and Cather, 1994).

The San Luis basin is roughly 200 km long and 70 km wide with Villa Grove, CO and Taos, NM situated at the approximate northern and southern ends of the basin (Fig. 1). Two half grabens are present in the northern basin, the western Monte Vista graben and the eastern Baca graben, separated by the Alamosa horst (Brister and Gries, 1994). The deepest segment of the San Luis basin occurs within the northwest-trending Baca graben along the west flank of the Sangre de Cristo Range (Kluth and Schaftenaar, 1994).

Recent gold and petroleum exploration, conducted on the Luis Maria Baca Grant No. 4, Saguache County, CO show that the northeastern San Luis basin is structurally analogous to other basins of the Rio Grande rift. Information presented in this paper is based on the results of geological mapping, exploration drilling and seismic, aeromagnetic and gravity surveys conducted in the vicinity of the Baca Grant.

## LITHOLOGIC UNITS

Lithologies in the northeastern San Luis basin and northern Sangre de Cristo Range are grouped into prerift and synrift units. Prerift rocks include Proterozoic metamorphic and intrusive rocks, Mesozoic sediments and Oligocene volcanic rocks. Paleozoic sediments, present in the Sangre de Cristo Range and at the north end of the basin are most likely present but have not been encountered in the subsurface in the vicinity of the Baca Grant. Eocene sediments of the Blanco Basin Formation, present in the Monte Vista graben (Brister

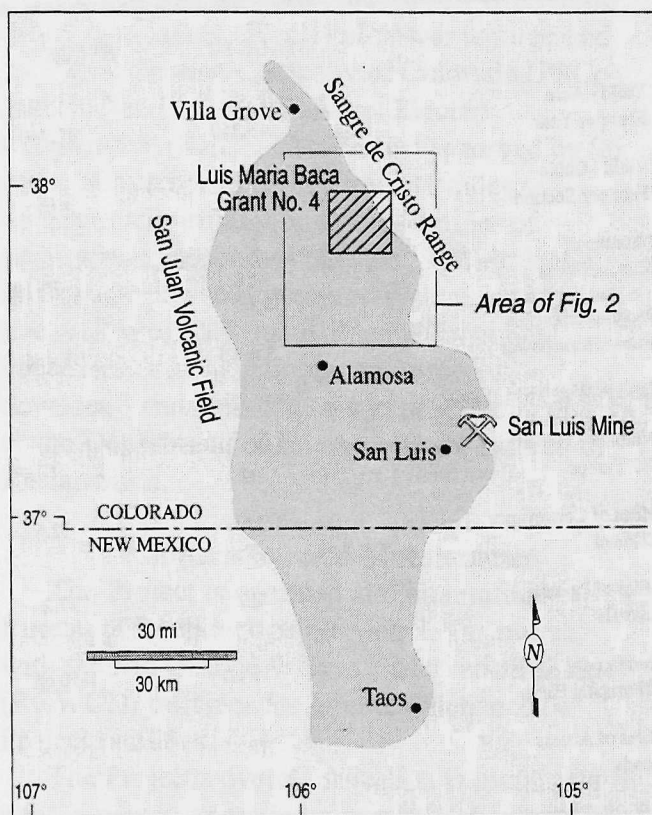

**Figure 1: Location map of the San Luis basin in south-central Colorado and north-central New Mexico, showing the location of the Luis Maria Baca Grant No. 4 and the San Luis gold mine. Modified from Brister and Gries (1994).**

and Gries, 1994), have not been observed along the northeastern margin of the Baca graben. Synrift rocks include Miocene - Pliocene sediments of the lower Santa Fe Group, the Pliocene - Pleistocene Alamosa Formation and Tertiary intrusive rocks. Much of the northeastern San Luis Valley floor is covered by deposits of Quaternary alluvium and

olian sand, which obscure outcrops of the Alamosa and Santa Fe formations.

## Prerift Rocks

### Proterozoic Rocks

Lindsey and others (1984, 1985a, 1985b, 1986, 1987), Johnson, Bruce and Lindsey (1989), Johnson and Bruce (1991) and Bruce and Johnson (1991) published a comprehensive set of geological maps of the northern Sangre de Cristo Range. Interlayered mafic and felsic gneiss, leucocratic granitic to granodioritic gneiss, quartz monzonite porphyry, medium-grained quartz monzonite and minor quartzite are the principal Proterozoic rocks in the range (Lindsey and others, 1986). In the immediate vicinity of the Baca Grant, biotite-rich augen gneiss, porphyritic quartz monzonite gneiss and amphibolite are the main Proterozoic rock types (Fischer, 1988). Chlorite, sericite and epidote are common alteration products.

### Mesozoic Sediments

A field check of color air photo anomalies and reconnaissance geological mapping along the southwest flank of the Sangre de Cristo Range resulted in the discovery of two outcrops of Mesozoic sediments, the first reported occurrences in the basin. Subsequently, 17 of 42 gold exploration drill holes, located close to the range front, encountered highly faulted sections of Mesozoic sediments in fault contact with Precambrian gneiss. Thin, highly faulted sections of Mancos Shale were penetrated by the Baca #1 and #2 wells located on the Baca Grant.

Cretaceous Mancos Shale and Dakota Group sandstones and Jurassic Morrison Formation occur as rotated blocks in the hanging wall of a low-angle, normal fault that forms the margin of the basin. Mineral exploration drilling has encountered up to 100 m of steeply dipping Dakota sandstone and Morrison Formation shale, siltstone and arkosic sandstone. Identification of the Dakota and Morrison formations has been by examination of drill cuttings and thin section analysis of outcrop samples. A palynology study of black shale collected from exploration drill holes confirmed the presence of Mancos Shale (Groth, 1994).

### Oligocene Volcanic Rocks

Brister (1990) summarized drill hole data from 11 oil and gas wells and one geothermal well drilled in the San Luis basin between 1951 and 1989. Wells drilled in the vicinity of the Baca Grant are shown on Figure 2. All of the wells penetrated Oligocene volcanic rocks that pre-date development of the Rio Grande rift. Intermediate-composition flows, breccias and volcanoclastic rocks of the Conejos Formation and various ash-flow tuffs, erupted from the San Juan volcanic field, are present in the basin. Ash flows of the Carpenter Ridge, Fish Canyon, Masonic Park and Treasure Mountain tuffs have been tentatively identified by Brister (1990). The well data indicates that, in the northern portion of the basin, early andesites and quartz latites of the Conejos

Formation pinch out on the Alamosa horst. Younger ash-flow tuffs extend as far east as the Amoco-Mapco well which was drilled on the east flank of the Alamosa horst. (Fig. 2).

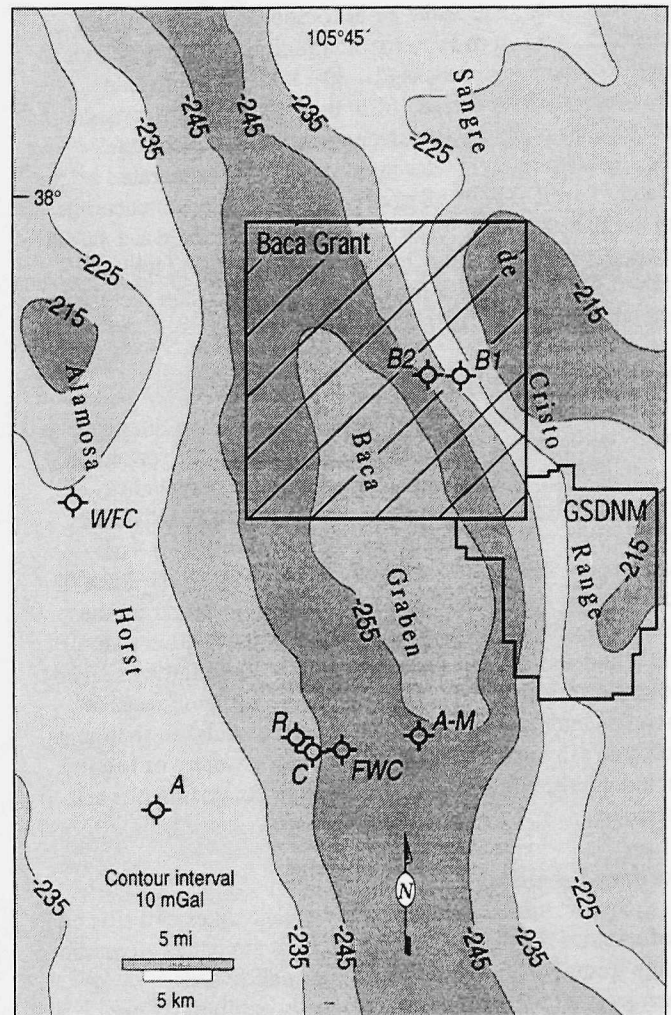

**Figure 2: Bouguer gravity map: NE San Luis basin with Alamosa horst, Baca graben and Sangre de Cristo Range. Wells in the area include WFC, W.F. Carr; A, Amerada; R, Reserve; C, Cougar; FWC, F. William Carr; A-M, Amoco-Mapco; B1, Baca #1 and B2, Baca #2.**

## Synrift Rocks

### Lower Santa Fe Group

The Miocene - Pliocene lower Santa Fe Group comprises the bulk of synrift sediments in the San Luis basin. Brister (1990), Brister and Gries (1994) and Wallace (1995) provide excellent descriptions of lower Santa Fe sediments.

Composition and grain size are highly variable and depend on source terrain, distance from source and position within the drainage system. The Baca #1 and Baca #2 wells, located on the Baca Grant and close to the present day mountain front (Fig. 3), penetrated thick intervals of Santa Fe sediments.

The Baca #1 well, located approximately two kilometers from the mountain front, encountered 1076 m of relatively uniform sediments dominated by poorly consolidated coarse sandstone, gravel and boulder conglomerate. The Santa Fe is composed almost entirely of clasts derived from Proterozoic granitic gneiss (>70%) and mafic metamorphic rocks (10-30%). Minor sandstone fragments (<5%) derived from the Dakota and Morrison formations occur in the lower portions of the section. Boulders up to one meter in diameter were penetrated by the Baca #1 well. The 1558 m of Santa Fe sediments encountered in the Baca #2 well, located 1.3 km west of the Baca #1, have a similar composition. Clast size in the Baca #2 well is generally smaller with fewer large boulders than were encountered in the Baca #1 well.

### **Alamosa Formation**

The Baca #2 well penetrated 354 m of the Pliocene - Pleistocene Alamosa Formation. In this well the formation consists of unconsolidated, fine-grained to gravel clasts of granitic and mafic metamorphic rock (80-100%), light tan, biotite-rich volcanic tuff (trace-20%) and black to dark brown peat and wood fragments (trace-5%). At the Baca #2 location the Alamosa Formation is distinguished from the underlying Santa Fe by 1) the overall smaller grain size, 2) the roundness of individual grains, 3) wood fragments and 4) volcanic rock fragments. East of this location the Alamosa includes interbedded lacustrine and volcanoclastic sediments, volcanic ash and sandstone that contain a variety of fossils, including avian and fish skeletal fragments, gastropods and ostracods.

### **Tertiary Intrusives**

Synrift intrusive rocks include felsic dikes and sills and mafic intrusives that occupy a variety of structures along the range front. Felsic rocks containing small feldspar phenocrysts (1-2 mm) and occasionally exhibiting flow banding occur in the footwall of the low-angle fault at the basin margin, in high-angle structures that cut across the range front and in Laramide thrust faults. Benson and Jones (1990) describe similar rocks at the San Luis mine that they interpret as being emplaced concurrently with development of the low-angle fault and gold mineralization. Mafic intrusives consisting primarily of coarse-grained, plagioclase and hornblende (Fischer, 1988) occur as small plugs, dikes and sills. The presence of mafic sills emplaced along the Deadman Creek thrust is evidence that these rocks post-date Laramide thrusting. Mafic dikes also occupy high-angle structures that are located close to and parallel the range-front fault, suggesting that at least some of the mafic intrusives occupy rift structures. The presence of unmineralized mafic

plugs adjacent to mineralized Proterozoic gneiss is further evidence that the intrusives post-date gold mineralization and were therefore emplaced during development of the rift.

## **STRUCTURE**

The geometry of the northeastern margin of the basin is dominated by a low-angle, normal fault linked to the early stages of rifting. Benson and Jones (1990) describe a nearly identical structure that hosts the San Luis gold deposit located near the town of San Luis (Fig. 2). McCaig (1982) mapped high-angle fault scarps in Quaternary deposits along the west flank of the Sangre de Cristo Range, an indication that the Sangre de Cristo fault is a high-angle, normal fault separating the mountain range from the deep basin. New data shows that the Sangre de Cristo fault exhibits relatively little vertical displacement. The northeastern margin of the deep basin is a high-angle fault located southwest of the range front, creating an intermediate fault block between the mountains and the Baca graben. Movement on listric normal faults present in the hanging wall of the low-angle structure may have controlled deposition of the Alamosa Formation along the northeastern margin of the basin.

### **Low-angle Structure**

The northeastern margin of the basin is a low-angle, normal fault that strikes northwest, parallel to the Sangre de Cristo Range and dips 25° - 30° southwest. Movement along this structure accommodated the deposition of at least 2600 m of synrift sediments in the basin. Keeping with Benson and Jones' (1990) description of the San Luis gold deposit, the structure is interpreted as a detachment-style fault that formed during the early stages of rifting.

The detachment surface is marked by a thin layer of clay gouge that is typically gray-green in color but can be a variety of colors depending on local changes in alteration of the footwall. Close to the mountain front, synrift sediments were deposited directly on clay gouge or a thin, highly sheared zone of Mesozoic sediments. The Baca #1 and #2 wells encountered thin, faulted section of Mancos Shale in the hanging wall of the detachment. High resolution seismic data shows that beds of the Santa Fe are truncated at the fault, indicating at least minor movement following deposition. Further into the basin, Santa Fe beds were deposited on rotated blocks of Mesozoic sediments that form the hanging wall of the detachment. The footwall of the detachment is predominantly brecciated Proterozoic gneiss. Aphanitic, porphyritic felsic dikes and sills are present locally.

Hydrothermal alteration of footwall rocks is similar to descriptions of the San Luis gold deposit by Benson and Jones (1990), ranging from intense silicification to quartz-sericite-pyrite and chlorite-carbonate-hematite assemblages. Rocks in the hanging wall of the fault have not been subjected to hydrothermal alteration.

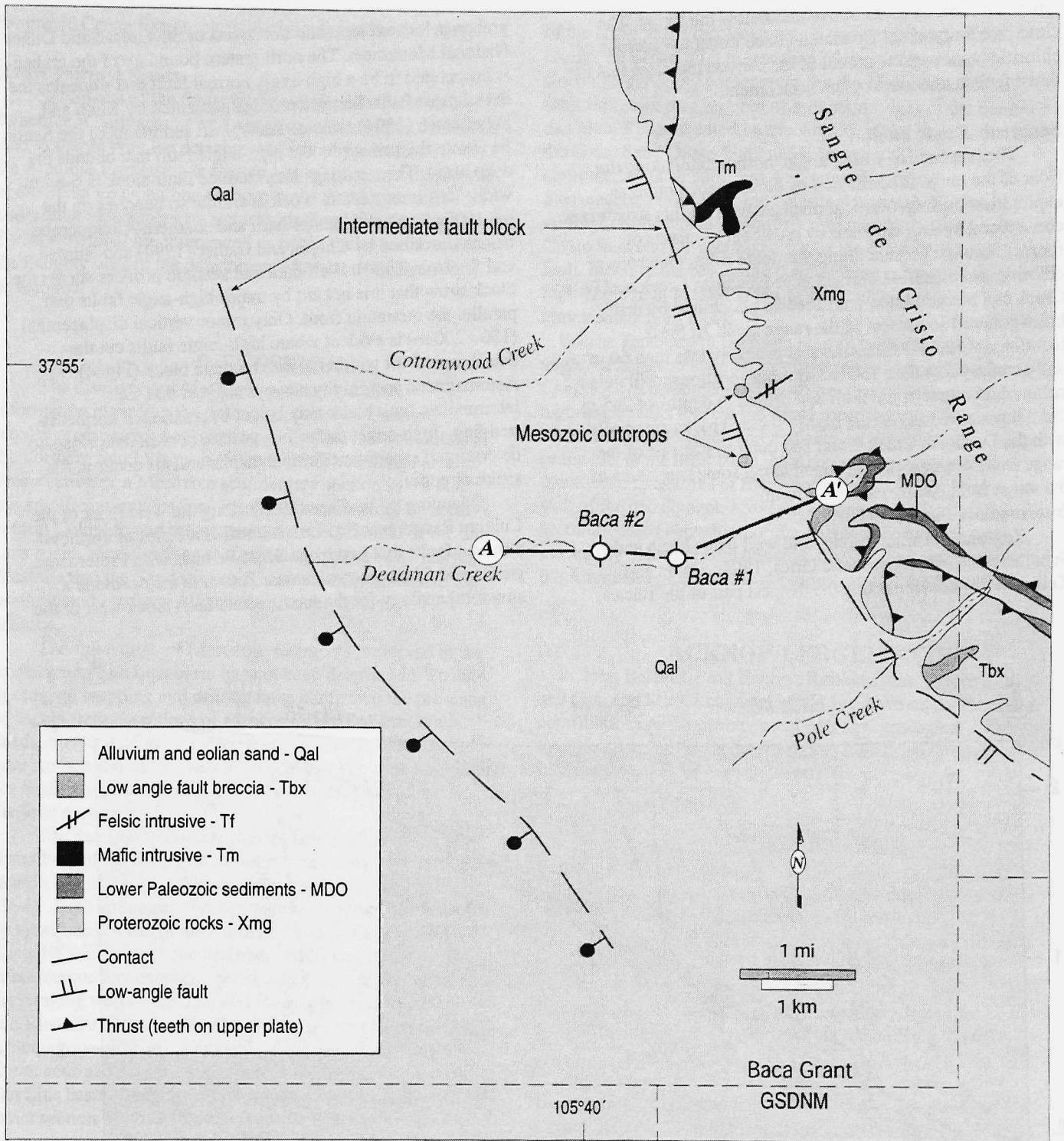

**Figure 3: Geologic map of the eastern Baca Grant. Modified from geological mapping by Limbach and Powell (1993).**

Erosional remnants of the footwall breccia are present at several locations along the west flank of the Sangre de Cristo Range (Fig. 3). The breccia typically consists of sub-angular to sub-rounded clasts of feldspar and quartz in a chloritic matrix, resulting in a rubbly texture with little or no foliation. Thickness of the breccia ranges from 5m to more

than 60m. Clement (1952) mapped a prominent outcrop of chloritic breccia at the mouth of the Deadman Creek canyon (Fig. 3) and interpreted it as part of the Deadman Creek thrust. The breccia is interpreted here to be part of the footwall of the detachment fault. The rubbly nature of the breccia contrasts markedly with well developed cleavage

typical of sheared rocks above and below the thrust. The close proximity of the Deadman Creek thrust to outcrops of chloritic breccia at the mouth of the canyon indicates that the thrust fault is truncated by the detachment.

### Sangre de Cristo Fault

The presence of a high-angle, normal fault along the front of the range is confirmed by close-spaced mineral exploration drilling. Vertical displacement on this structure is constrained by drill data and by erosional remnants of footwall breccia present along the range front. Outcrops of chloritic and silicified breccia near Deadman Creek and Pole Creek can be correlated with breccia penetrated by drill holes collared southwest of the range front. At these locations, vertical displacement is probably less than 60 m and certainly less than 150 m. At other locations, drill holes collared just west of the fault and drilled to depths of 245 m did not penetrate any of the highly sheared rocks associated with the Deadman Creek thrust that outcrop just east of the range front. Vertical displacement along some segments of the range front clearly exceeds 250 m.

### Intermediate Fault Block

Regional seismic, gravity and well data (Kluth and Schaftenaar, 1994; Brister and Gries, 1994; Davis and Keller, 1978) document that the deepest part of the Baca

graben is located west and northwest of the Great Sand Dunes National Monument. The northeastern boundary of the graben is interpreted to be a high-angle normal fault that truncates the detachment fault. Seismic profiles presented by Kluth and Schaftenaar (1994) indicate that synrift sediments of the Santa Fe Group thicken across the high-angle fault that bounds the deep basin. The resulting intermediate fault block is 6-8 km wide. This intermediate block is similar to benches on the master fault sides of the northern and southern Albuquerque basins described by Chapin and Cather (1994) and Russell and Snelson (1994). Well data and seismic profiles across the block show that it is not cut by major high-angle faults that parallel the mountain front. Only minor vertical displacement (150 - 200 m) is evident where high-angle faults cut the detachment fault within the intermediate block (Fig. 4). Aeromagnetic and gravity surveys suggest that the intermediate fault block may be cut by a series of northeast-trending, high-angle faults. No seismic or well data exists to determine if significant vertical displacements occur in the strike direction.

Mapping by Wallace (1995) along the west flank of the Culebra Range near San Luis identified a series of northeast-trending faults that juxtapose Santa Fe beds with Proterozoic gneiss and Oligocene volcanics. This area may provide a structural analogy for the intermediate fault block west of the

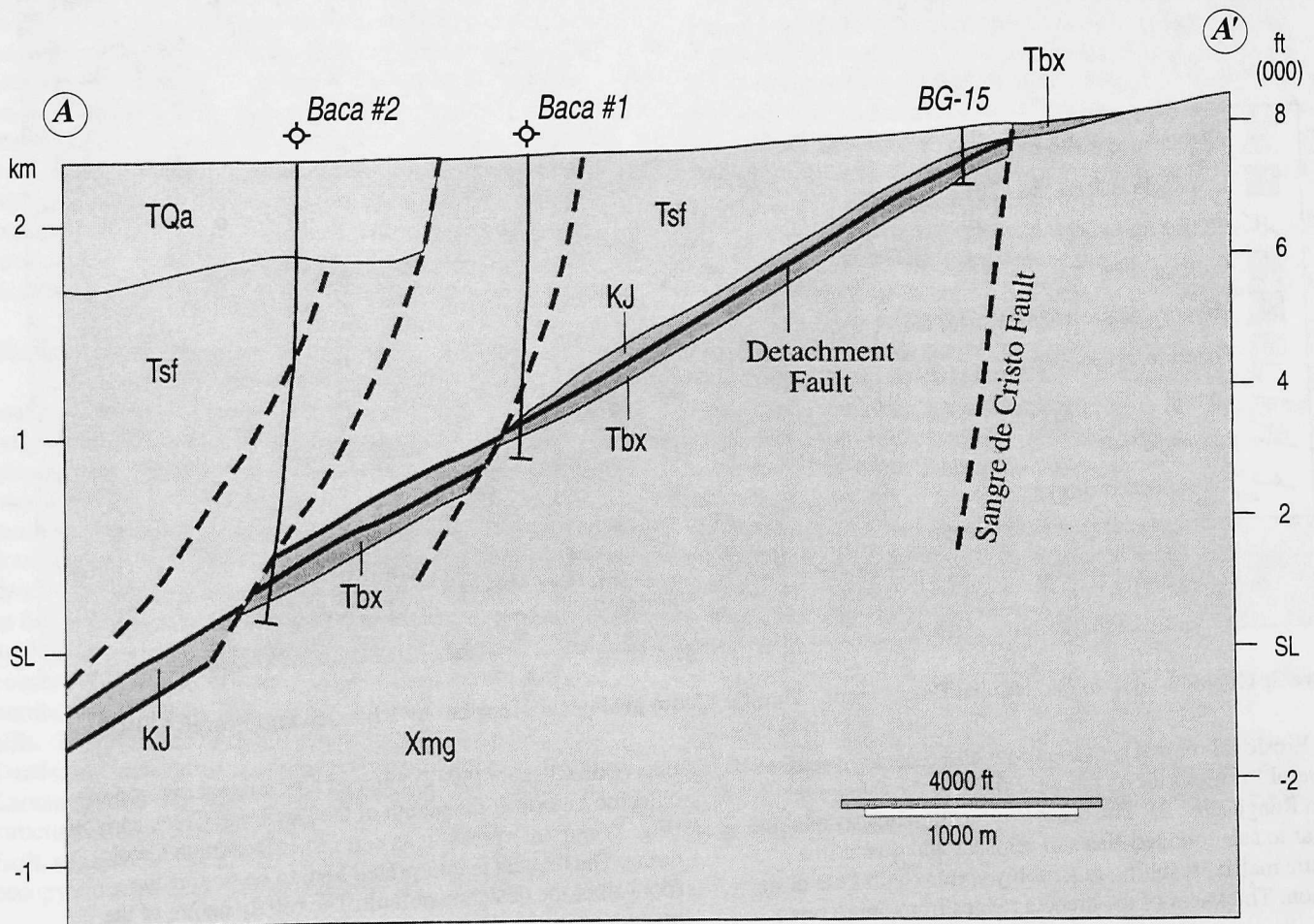

Figure 4: Geological cross section across that part of intermediate block confirmed by drilling. TQa, Alamosa Formation; Tsf, lower Santa Fe Group; KJ, Mesozoic sediments; Tbx, low-angle fault breccia; Xmg, Proterozoic gneiss.

Sangre de Cristo Range, particularly in the strike direction.

### **Listric Normal Faults**

Sediments of the Santa Fe Group deposited above the detachment fault are cut by a series of listric normal faults that tend to merge with the detachment. East of the Baca #2 well, the Alamosa Formation is faulted against coarse conglomerate of the Santa Fe along one or more faults that do not offset the underlying detachment by a corresponding amount (Fig. 4). These structures are interpreted as listric faults that formed in the hanging wall of the detachment after the deep basin developed.

## **DISCUSSION**

The discovery of Mesozoic sediments and new information regarding the geometry of the basin margin require modifications to existing geological interpretations of the northern San Luis basin/ Sangre de Cristo Range area. Preservation of a Mesozoic sedimentary section in the basin has significant implications for the tectonic history of south-central Colorado and the natural resource potential of the San Luis basin. Modifications to the geology of the basin margin illustrate that the San Luis basin is structurally similar to the northern and southern Albuquerque basins of central New Mexico.

The full extent of Mesozoic sediments preserved in the northeastern San Luis basin has not been determined. To date, geological mapping and drilling have confirmed the presence of highly faulted sections of Mancos Shale, Dakota Group sandstones and Morrison Formation sediments. Widespread, near surface shows of live, Cretaceous oil along the margin of the basin are evidence that a significant section of Mancos Shale is present.

The San Luis basin detachment fault is analogous to the Santa Fe fault, a low-angle structure that forms the western margin of the southern Albuquerque basin (May and Russell, 1994). Both structures contain faulted Mancos Shale overlain by synrift sediments of the Santa Fe Group. The Humble-Santa Fe Pacific well, located about 8 km east of the Albuquerque basin margin, penetrated Mesozoic sediments in the hanging wall of the Santa Fe fault. (May and Russell, 1994 and Russell and Snelson, 1994). Using the Santa Fe fault and Albuquerque basin as an example, the presence of faulted Cretaceous and Jurassic sediments in the hanging wall of the San Luis basin detachment fault suggests that a relatively intact section of Mesozoic sediments is likely to be present in the northeastern San Luis basin. The exact timing and mechanism responsible for preserving Mesozoic sediments is yet to be determined. It is apparent however that the entire Mesozoic section was not eroded from all of the northern San Luis basin/ Sangre de Cristo Range area during the Laramide.

Historically, the Sangre de Cristo fault has been interpreted as a high-angle fault with as much as 7.6 km of vertical displacement (Davis and Keller, 1978; Tweto, 1979; Brister and Gries, 1994 and Kluth and Schaftenaar, 1994). Drill data which document the intermediate fault block and accompanying detachment fault along the northeastern margin

of the basin limits displacement on some segments of the Sangre de Cristo fault to less than 60 m. An apparent dip slope that generally conforms to the dip of the detachment fault is present on a number of mountain ridges of the Sangre de Cristo Range located in the vicinity of the Baca Grant and the Great Sand Dunes National Monument. This dip slope, combined with seismic and well control across the intermediate fault block, indicates that as much as 6 km of vertical displacement previously assigned to the Sangre de Cristo fault can be accounted for by the dip of the detachment fault. Much of the remaining displacement is taken up by the high-angle fault located at the western edge of the intermediate fault block.

The geometry of the basin margin suggests that low-angle, detachment style faults characterize early rifting. Continued development of the rift transferred movement to high-angle faults that cut the detachment, creating the intermediate fault block and a thicker section of synrift sediments in the deep basin. Movement was subsequently transferred to a series of listric normal faults in the hanging wall of the detachment. Movement along these faults accommodated deposition of the Alamosa Formation and eventually placed unconsolidated, fine-grained sediments of the Alamosa against coarse conglomerates of the Santa Fe.

## **ACKNOWLEDGEMENTS**

John Belcher, Peak Energy; Robbie Gries, Priority Oil and Gas; and Mark Longacre, MBL, Inc. have made important contributions to the development of a new geological interpretation for the northeastern San Luis basin through interpretation of the data and lively discussions.

## **REFERENCES**

- Benson, R. G., and Jones, D. M., 1990, Geology of the San Luis gold deposit, Costilla County, Colorado, *in* Hausen, D. M., Halbe, D. N., Petersen, E. U. and Tafuri, W. J., eds., *Gold '90: Proceedings of the Gold '90 Symposium*, Salt Lake City, Utah: Littleton, Colorado, Society for Mining, Metallurgy, and Exploration, Inc., p. 83-91.
- Brister, B. S., Tertiary sedimentation and tectonics: San Juan sag-San Luis basin region, Colorado and New Mexico [Ph.D. thesis]: Socorro, New Mexico Institute of Mining and Technology, 267 p.
- Brister, B. S. and Gries, R. R., 1994, Tertiary stratigraphy and tectonic development of the Alamosa basin (northern San Luis Basin), Rio Grande rift, south-central Colorado, *in* Keller, G. R. and Cather, S. M., eds., *Basins of the Rio Grande rift: Structure, stratigraphy and tectonic setting*: Boulder, Colorado, Geological Society of America Special Paper 291, p. 39-58.
- Bruce, R. M. and Johnson, B. R., 1991, Reconnaissance geologic map of parts of the Zapata Ranch and Mosca Pass quadrangles, Alamosa and Huerfano Counties, Colorado: U. S. Geological Survey, Miscellaneous Field Studies Map MF-2168, scale 1:24,000.

- Chapin, C. E. and Cather, S. M., 1994, Tectonic setting of the axial basins of the northern and central Rio Grande rift, *in* Keller, G. R. and Cather, S. M., eds., Basins of the Rio Grande rift: Structure, stratigraphy and tectonic setting: Boulder, Colorado, Geological Society of America Special Paper 291, p. 5-25.
- Clement, J. F., 1952, The geology of the northeastern Baca Grant area, Saguache County, Colorado [M.S. thesis]: Golden, Colorado School of Mines, 129 p.
- Davis, G. H. and Keller, G. R., 1978, Subsurface structure of San Luis Valley, *in* Hawley, J. W., ed., Guidebook to Rio Grande rift in New Mexico and Colorado: New Mexico Bureau of Mines and Mineral Resources Circular 163, p. 28.
- Fischer, J. F., 1988, Petrographic report of samples from the Sangre de Cristo Range, Colorado: unpublished report prepared for Abermin, Inc., 111 p.
- Groth, P., 1995, Palynology and kerogen observations of samples from drill hole BG-34, Baca Land Grant, San Luis Valley, Colorado: unpublished report prepared for Lexam Explorations (U.S.A.) Inc., 23 p.
- Johnson, B. R., Bruce, R. M. and Lindsey, D. A., 1989, Reconnaissance geologic map of the Medano Pass quadrangle and part of the Liberty quadrangle, Alamosa, Huerfano and Saguache Counties, Colorado: U. S. Geological Survey, Miscellaneous Field Studies Map MF-2089, scale 1:24,000.
- Johnson, B. R. and Bruce, R. M., 1991, Reconnaissance geologic map of parts of the Twin Peaks and Blanca Peak quadrangles, Alamosa, Costilla and Huerfano Counties, Colorado: U. S. Geological Survey, Miscellaneous Field Studies Map MF-2169, scale 1:24,000.
- Kluth, C. F. and Schaftenaar, C. H., 1994, Depth and geometry of the northern Rio Grande rift in the San Luis basin, south-central Colorado, *in* Keller, G. R. and Cather, S. M., eds., Basins of the Rio Grande rift: Structure, stratigraphy and tectonic setting: Boulder, Colorado, Geological Society of America Special Paper 291, p. 27-37.
- Limbach, F. W. and Powell, J. L., 1993, Geological map of a portion of the northeastern Baca Grant, unpublished map prepared for Challenger Gold, Inc., scale 1:12,000.
- Lindsey, D. A., Scott, G. R., Soulliere, S. J. and DeAngelis, B. L., 1984, Geologic map of the Horn Peak quadrangle, Custer and Saguache Counties, Colorado: U. S. Geological Survey, Miscellaneous Field Studies Map MF-1623, scale 1:24,000.
- Lindsey, D. A., Soulliere, S. J., and Hafner, K., 1985, Geologic map of Electric Peak and southwestern part of Beckwith Mountain quadrangles, Custer and Saguache Counties, Colorado: U. S. Geological Survey, Miscellaneous Field Studies Map MF-1786, scale 1:24,000.
- Lindsey, D. A., Soulliere, S. J., Hafner, K. and Flores, R. J., 1985, Geologic map of Rito Alto Peak and northeastern part of Mirage quadrangles, Custer and Saguache Counties, Colorado: U. S. Geological Survey, Miscellaneous Field Studies Map MF-1787, scale 1:24,000.
- Lindsey, D. A., Johnson, B. R., Soulliere, S. J., Bruce, R. M. and Hafner, K., 1986, Geologic map of the Beck Mountain, Crestone Peak and Crestone quadrangles, Custer, Huerfano and Saguache Counties, Colorado: U. S. Geological Survey, Miscellaneous Field Studies Map MF-1878, scale 1:24,000.
- Lindsey, D. A. and Soulliere, S. J., 1987, Geologic map and sections of the Valley View Hot Springs quadrangle, Custer and Saguache Counties, Colorado: U. S. Geological Survey, Miscellaneous Field Studies Map MF-1942, scale 1:24,000.
- May, S. J. and Russell, L. R., 1994, Thickness of the syn-rift Santa Fe Group in the Albuquerque basin and its relation to structural style, *in* Keller, G. R. and Cather, S. M., eds., Basins of the Rio Grande rift: Structure, stratigraphy and tectonic setting: Boulder, Colorado, Geological Society of America Special Paper 291, p. 113-134.
- McCalpin, J. P., 1982, Quaternary geology and neotectonics of the west flank of the northern Sangre de Cristo Mountains, south-central Colorado: Colorado School of Mines Quarterly, v. 77, no. 3, 97 p.
- Russell, L. R. and Snelson, S., 1994, Structure and tectonics of the Albuquerque basin segment of the Rio Grande rift: Insights from reflection seismic data, *in* Keller, G. R. and Cather, S. M., eds., Basin of the Rio Grande rift: Structure, stratigraphy and tectonic setting: Boulder, Colorado, Geological Society of America Special Paper 291, p. 83-112.
- Tweto, O., 1979, The Rio Grande rift system in Colorado, *in* Riecker, R. E., ed., Rio Grande rift: Tectonics and magmatism: Washington, D.C., American Geophysical Union, p. 33-56.
- Wallace, A. R., 1995, Cenozoic rift-related sedimentation and faulting, northern Culebra Range, southern Colorado: New Mexico Geological Society, 46th Field Conference, Geology of the Santa Fe Region, Guidebook, p. 147-154.



# THE ANALYSIS OF RABBITBRUSH (genus *CHRYSOTHAMNUS*) AND THE DETECTION OF A POSSIBLE HIDDEN GEOTHERMAL FIELD IN THE NORTHERN SAN LUIS VALLEY



James A. Erdman  
2125 Estes Street, Lakewood, Colorado 80215

## ABSTRACT

The San Luis Valley lies between the low foothills of the San Juan Volcanic Field to the west and the steeply rising Sangre de Cristo Range to the east. Two Known Geothermal Resource Areas (KGRAs), Mineral Hot Springs and Valley View Hot Springs, lie in the northern part of the valley (figure).

Although these two hot springs are associated with the geomorphic expression of the northern San Luis Valley—the Rio Grande Rift—they are spatially and geochemically dissimilar (Barrett and Pearl, 1976, table 1; 1978). Mineral Hot Springs (springwater temperatures: 32°–55°C) is located in valley fill about midway between the San Juan

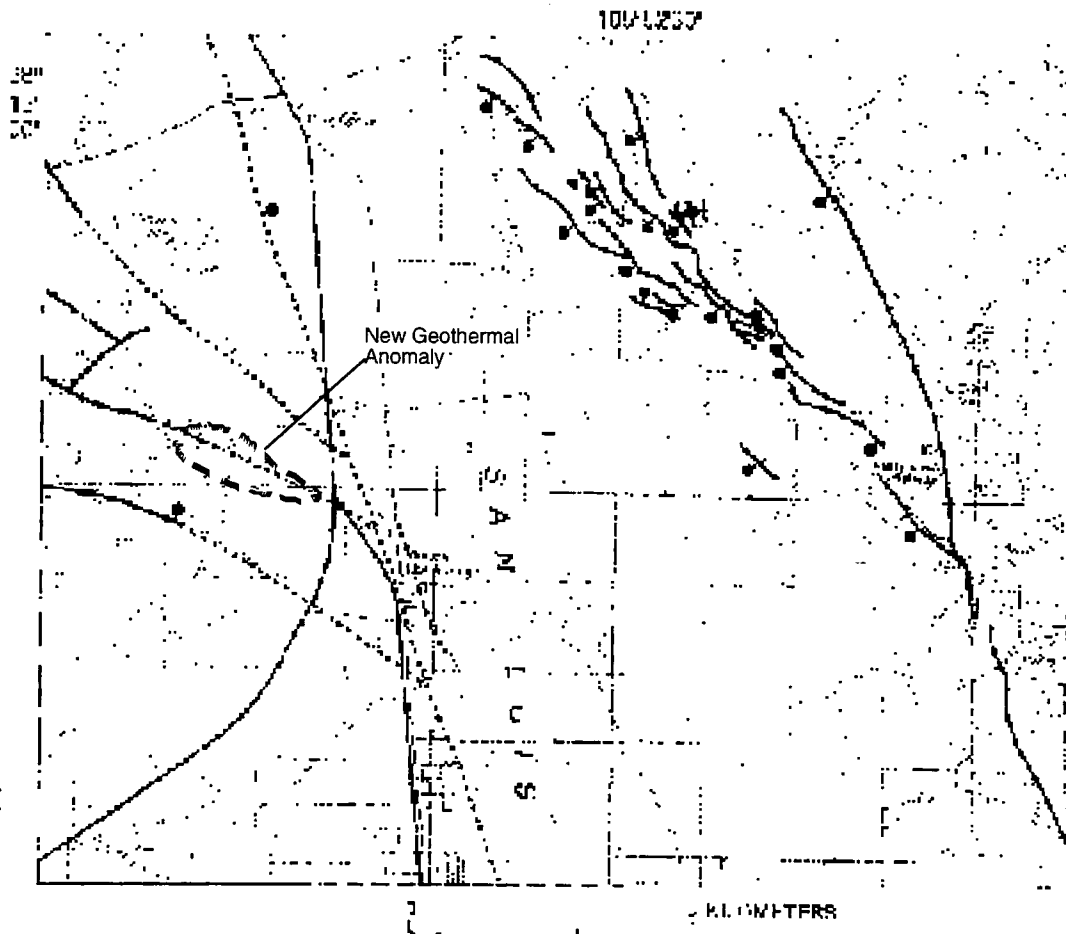

Location of possible hidden geothermal field in relation to mapped faults and the two Known Geothermal Resource Areas, northern San Luis Valley.

Volcanic Field and the Sangre de Cristo Range, about 9 km south of the town of Villa Grove, Colorado. Valley View Hot Springs (springwater temperatures: 31°–33°C) lies on the prominent range-front fault on the western edge of the Sangre de Cristos.

To seek evidence for possible extensions of these hot-spring systems, the U.S. Geological Survey conducted surveys of the area, funded by the U.S. Department of Energy's Geothermal Technology Division, using geochemical methods that included biogeochemistry—plant-tissue analysis. A total of 139 samples of rabbitbrush (*Chrysothamnus parryi* subspecies *howardii* [Parry] Hall and Clem. and, to a lesser extent, *C. nauseosus* ssp. *consimilis* [Greene] Hall and Clem.) were collected, mostly along road traverses. Soil-gas and minus-80 mesh soil samples—also collected along road traverses—totaled 396. Many of the geochemical anomalies coincided with the large fault systems of the valley. Although the surveys did not detect any extensions of the Valley View Hot Springs KGRA, a cluster of anomalous sites on the west side of the valley seemed to be related indirectly to the Mineral Hot Springs KGRA.

High concentrations of lithium, boron, and manganese in rabbitbrush samples (Erdman and VanTrump, 1993) suggest that a geothermal heat source may occur within the low hills of Lower Proterozoic granites just to the west of the Mineral Hot Springs. The location of this suite of element-concentration anomalies in the plants adjoins a traverse with high mercury concentrations in associated soils and anomalous carbon dioxide concentrations in soil gases (Hinkle, 1993; Motooka and others, 1994; Hinkle and Erdman, 1995).

Other geochemical spatial patterns, unrelated directly to geothermal resources, included the areal coincidence of surficial geochemical and biogeochemical anomalies with concealed subsurface faults detected by a resistivity survey (Zohdy and Bisdorf, 1993). Also, bromine-enriched rabbitbrush was located over an extensive area of presumably deep valley fill. Bromine is highly mobile under all pH/Eh conditions in the supergene environment. Two sources are likely: (i) tuff-laden lacustrine clays of the Neogene Alamosa Formation, which also consists of unconsolidated sands; and (ii) biogenic gases in the same formation or oil seeps, perhaps in the underlying Precambrian rocks. These gases may have created redox conditions that are known to produce bromine and iodine anomalies in soils.

## REFERENCES

- Barrett, J.K., and Pearl, R.H., 1976, Hydrogeological data of thermal springs and wells in Colorado: Colorado Geological Survey, Department of Natural Resources, Information Series No. 6, 114 p.
- \_\_\_\_\_, 1978, An appraisal of Colorado's geothermal resources: Colorado Geological Survey, Department of Natural Resources, Bulletin 39, 224 p.
- Erdman, J.A., and VanTrump, George, 1993, Analytical results, basic statistics, and locality map of rabbitbrush (genus *Chrysothamnus*) samples from the Mineral Hot Springs and Valley View Hot Springs Known Geothermal Resource Areas, northern San Luis Valley, Colorado: U.S. Geological Survey Open-File Report 93-17, 18 p.
- Hinkle, M.E., 1993, Concentrations of N<sub>2</sub>, O<sub>2</sub>, CO<sub>2</sub>, and He in soils gases collected in the northern San Luis Valley, Colorado: U.S. Geological Survey Open-File Report 93-584, 16 p.
- Hinkle, M.E., and Erdman, J.A., 1995, Geochemical and biogeochemical surveys near the Mineral and Valley View Hot Springs Known Geothermal Resource Areas, northern San Luis Valley, Colorado: U.S. Geological Survey Open-File Report 95-569, 44 p.
- Motooka, J.M., O'Leary, R.M., Fey, D.L., and Hinkle, M.E., 1994, Analytical results for soil samples collected in the northern San Luis Valley, Colorado: U.S. Geological Survey Open-File Report 94-297, 25 p.
- Zohdy, A.A.R., and Bisdorf, R.J., 1993, A direct-current resistivity survey near Mineral Hot Springs, San Luis Valley, Colorado: U.S. Geological Survey Open-File Report 93-282, 61 p.



# THE ROLE OF STREAMS IN THE DEVELOPMENT OF THE GREAT SAND DUNES AND THEIR CONNECTION WITH THE HYDROLOGIC CYCLE

By  
Andrew D. Valdez  
Great Sand Dunes National Monument  
11500 Hwy 150  
Mosca, CO 81146



The Great Sand Dunes National Monument is home to a 39 square mile dune field whose complexity belies its relatively small size. The complexity manifests itself as diverse dune development resulting from the interaction of wind and water, and the nature in which their flow is controlled by the local mountain front. The bimodal to complex winds are responsible for creating the dunes, while the streams influence the features of the dune field. Because of the importance of the streams in maintaining the dune system, aspects of the hydrologic cycle at the Great Sand Dunes National Monument Area are studied and monitored to learn how to relate climatic conditions to stream flows and the state of the dune field.

## THE ROLE OF STREAMS IN DUNE FIELD DEVELOPMENT

There are two streams that flow along segments of the dune field perimeter. Medano Creek flows along the east and southeastern sides of the dune field and Sand Creek flows along the northwestern side, (see Figure 2). Both completely infiltrate into the ground water system, although Sand Creek occasionally reaches some playa lakes located 10 miles from the mountain front. Discharge has been measured on each stream since 1992 with Parshall flumes placed near where the streams enter monument property. Sand Creek is the larger of the two. Its peak flow has ranged from 54 to 225 cubic feet per second (cfs) and occurs in May and June. Its base flow varies from 0 to 1 cfs. Medano Creek's peak flow has fluctuated from 9 to 65 cfs and base flows are consistently 2-3 cfs.

The streams have a give and take relationship with the dune field. They erode sand from some parts of the dune field and deposit it in others. Each exhibits a net erosion of sand from along the mountain front and

deposition on the valley floor during high runoff periods. As flows decrease, the depositional areas dry up, exposing wide, braided channels so that the prevailing winds from the southwest can blow the sand back into the dune field. This results in the dune field having a crescent shape and the thickest sand deposits (up to 750 feet in relief) occurring down wind from the creeks (see figure 1). Each lobe of the crescent is an accumulation of the sand supplied by the streams and the great thickness comes from vertical dune growth allowed by the excess sand and multiple wind directions. Medano Creek is smaller than Sand Creek, but it builds a larger lobe because its erosional section has a longer contact with the dune field.

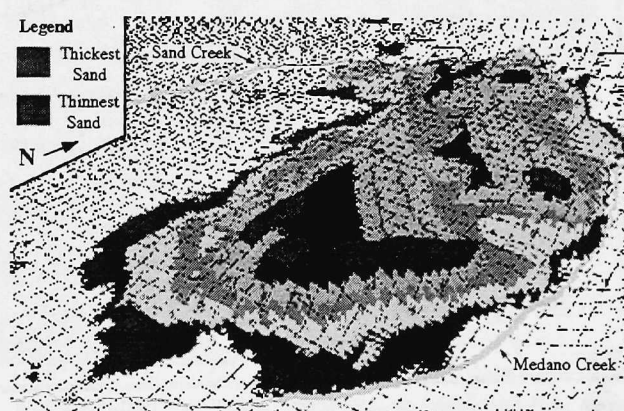

Figure 1. Sand thickness above the San Luis Valley plain. Created by the GIS division of the Rocky Mountain Regional Office, National Park Service.

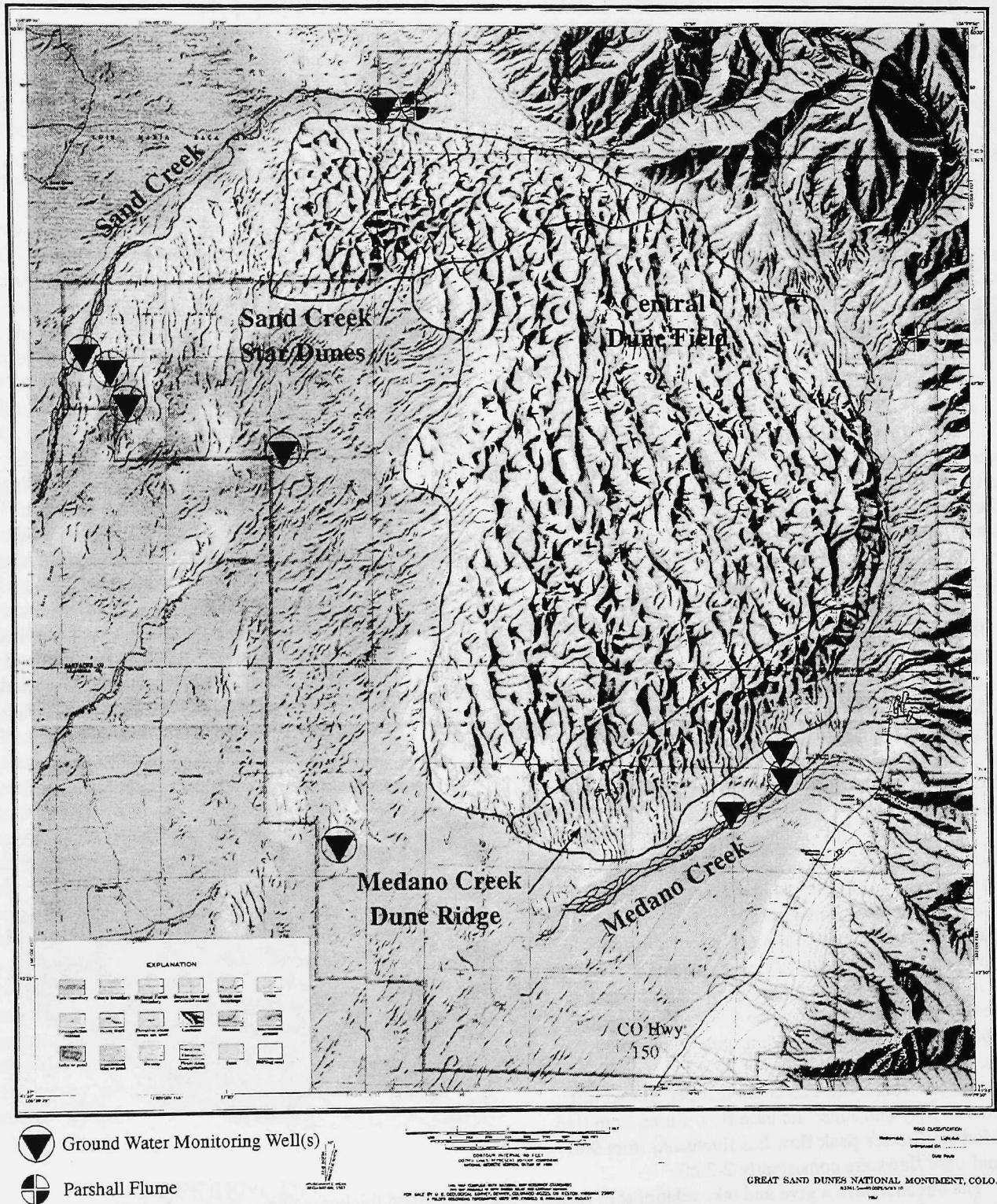

Figure 2. Location of Medano and Sand Creeks, monitoring wells, and Parshall flumes at the Great Sand Dunes National Monument. Modified from USGS map Great Sand Dunes National Monument, Colo.

Medano and Sand Creeks are particularly effective at transporting sand because surge flow can develop in their braided channel sections. Each surge is a pulse of water occurring in regular intervals that can potentially flush more sand down the stream than steady flow. It is a rare phenomena because it requires a high flow regime and a smooth, mobile channel. The fast flow creates bed forms called antidunes. They increase the amount of water stored in the areas where they develop by 20 percent, since they force the water to flow over a sinuous surface instead of a flat surface. The antidunes are not stable and eventually break, releasing the stored water. Since the channel is sandy and creates little turbulence, the pulse of water produced by the collapse of the antidune continues downstream in a discrete packet and picks up more water from other antidune fields (Bean, 1977; Schumm et al., 1982). Surge flow develops better on Medano Creek because its braided channel segment is steeper.

The magnitude of the surge waves depends on water depth. When flows are at the upper discharge levels, the surge wave can be up to one foot high and have a period of 90 seconds. At lower flows, the waves are only a few inches high and have periods less than one minute. In areas where only a thin sheet of water is flowing, several tiny pulses can form in a second.

The action of the creeks contribute to two of three distinct regions of dune development, see figure 2 (Valdez, 1992). The area along Medano Creek is known as the Medano Creek ridge. The thick sand deposits and closely spaced reversing dunes are a direct response to the availability of sand supplied by Medano Creek. Even the close spacing and aggregational nature of the north trending dunes cannot hold all the sand supplied to them, so a second northeast trending ridge fills their troughs and forms the horizon of the ridge. This gives the area an appearance more similar to a sand mountain range than individual dunes. The second area that shows stream affects is known as the Sand Creek star dunes. The many star dunes are the result of a complex wind regime, but a sequence of transverse dunes leading from the Sand Creek floodplain to the star dunes indicate that the source of their sand is Sand Creek. The third area, the central dune field, isn't affected by the streams and as a result displays the simplest dune formation. It has large north trending reversing dunes, with an occasional star dune, that are separated by vegetated troughs. Without the influence of the streams, the entire dune field would probably look like the central dune field and it would likely be oval shaped.

## **THE CONNECTION OF THE STREAMS TO THE REST OF THE HYDROLOGIC CYCLE**

The importance of the streams in the dune system was first realized in the early 1990s. Since then, the National Park

Service (NPS) has aspired to better understand their function. Research and monitoring by the NPS and others have laid the groundwork for the these goals to be reached. The first work was intended to explore the scope of the water resources and to start collecting baseline data. After the nature of the water systems was known, then efforts to quantify the effects of the streams and predict how they would react to changes in the local hydrologic cycle were begun.

The stimulus for all the work done since 1990 was a ground water development project proposed on a ranch adjacent to the Great Sand Dunes National Monument. It was designed to withdraw 200,000 acre-feet each year and predicted a lowering of the water table of 150 feet along the monument boundary. The potential for such a drastic change created a real need to understand the relationship between the ground water and the dune field and other natural resources and to predict if those changes were a threat to the goals of the NPS.

The initial projects were intended to determine where the sand moisture within the dunes came from and the type of connection between the streams and ground water. The sand moisture was extracted by flushing a sand core with distilled and deionized water. A chemical analysis of the effluent indicated that the source of the residual moisture was precipitation. Two methods were used to determine the interaction of the streams with ground water. The first was to drill 21 ground water monitoring wells throughout the park and place Parshall flumes on Sand and Medano Creeks. The second used Schlumberger soundings and resistivity testing to map the water table near the creeks. Twelve of the monitoring wells have automated gauging equipment installed while the others are periodically measured manually. The data collected thus far indicates seasonal fluctuations in the water table of up to 10 feet in shallow wells (20 feet) near the Sand and Medano Creeks and fluctuations of < 1 foot in deeper creek wells (100 feet) and wells away from the streams. Most of the wells indicate a simple, surficial aquifer, but the wells drilled into Medano Creek suggest as many as three aquifers levels are within 100 feet of the surface (Hadlock, 1995). The geophysical methods verified the effluent nature of the streams as well as noting differences in hydrologic characteristics of Sand Creek along the mountain front and out in the valley plain (Harmon et al, 1992). It also found areas were Sand Creek was seasonally influent. Both studies predicted that any significant lowering of the water table would increase the gradient between the streams and ground water and decrease the extent and volume of flow, the ability for surge flow to develop, and the ability of these streams to transport sand. With this information in hand, the NPS and other agencies filed an opposition to the water development project and defeated it in water court.

The current research seeks to quantify the role of Medano Creek and predict its effects based on measuring other parameters of the hydrologic cycle. Twenty four survey stations are located every 1,000 feet along the length of Medano Creek's braided channel. Each year, before spring runoff and after the creek has receded, a stream bed profile is surveyed. Changes in the profile are used to calculate the volume of sand moved by the creek during its runoff period and by the wind when the channel is dry. After the first year of the study, the erosion-deposition boundary was found to be 1,000 feet upstream from the dunes parking lot. An average of two feet of sand accumulated in the channel downstream of the parking lot which represents  $2 \times 10^7$  cubic feet of sand deposited by a flow of 8,500 acre-feet. This project will continue at least two more years to define any exponential changes that may occur with differing runoff levels.

The parts of the hydrologic cycle of interest to the NPS are how the snowpack, storm runoffs, and the position of the water table relate to stream flow rates and duration. A Snotel site was installed near the headwaters of Medano Creek in October of 1995. It measures the water content of the snowpack and precipitation. Although it will take several years to define statistical parameters, its data will be directly compared to runoff characteristics. When combined with information about how the creek is advancing and receding, changes in the water table, and stream discharge, then a better understanding of the hydrologic cycle will exist.

The quest to understand the role of streams in the maintenance of the dune field and how it could be affected by changes in the hydrologic cycle is a work in progress. Hydrologic conditions vary yearly and climatic trends change, therefore all the hydrologic measurement are setup as monitoring projects that operate on an ongoing manner.

The cycle is actually quit simple. It is evident that the snow in the mountains melts, flows down the streams, carries sand, and soaks into the ground (minus the evapotranspiration component). Predicting what changes in any part of the cycle would do to the other parts is not so simple.

## REFERENCES CITED

- Bean, D. W. 1977. Pulsating Flow in Alluvial Channels. M. S. Thesis. Geology Department. Colorado State University, Ft. Collins, CO
- Hadlock, G. L. 1995. Groundwater and Surfacewater Interactions along Lower Medano Creek, Great Sand Dunes National Monument, Colorado. M. S. Thesis. Geology Department. Utah State University, Logan, Utah. 69 pp.
- Harmon, E. J. and M. F. Hajicek. 1992. Schlumberger Soundings and Sand-Column Resistivity Testing for Determining Stream-Aquifer Connection, Great Sand Dunes National Monument, Colorado. Submitted to National Park Service.
- Schumm, S. A., D. W. Bean, and M. D. Harvey. 1982. Bed-Form Dependant Flow in Medano Creek, Southern Colorado. *Earth Surface Processes and Landforms*. Vol. 7. pp. 17-28.
- Valdez, A. D. 1992 (in press). Sand Supply and Wind Regime as Related to Dune Field Development at the Great Sand Dunes National Monument, Colorado. Great Sand Dunes Researchers Symposium. Submitted to National Park Service.



# ALAMOSA RIVER WATERSHED PROJECT

By

Jeff M. Stern

Conejos County Soil Conservation District

P.O. Box 255

La Jara, CO 81140



## INTRODUCTION

The Alamosa River watershed comprises 127,000 acres in the San Luis Valley of south central Colorado. The main stem of the river is 53 miles long. Several streams that spill off the east side of the Continental Divide join to form the Alamosa River, which eventually dissipates in wetlands near the Rio Grande.

Some of Colorado's oldest settlements are found in the Alamosa River watershed. Principal towns in or close to the watershed include La Jara (population 725), and Capulin, an unincorporated settlement of 150.

Over half the watershed is in public land managed by the U.S. Forest Service (Rio Grande National Forest) and the U.S. Bureau of Land Management.

Agriculture is the primary industry in the watershed. Close to 50,000 acres are irrigated. Principal crops include alfalfa hay, potatoes and barley. The area's many ranches raise cattle and sheep.

Portions of the lower Alamosa River were straightened (channelized) in the early 1970s to prevent flooding in Capulin. In the ensuing 25 years, straightening has created major problems for 40 ditch companies that divert water from the river to irrigate fields. The unstable, erosion-prone river threatens irrigation structures, homes, land, roads and bridges. Riparian areas have been degraded.

Stabilizing the river as it flows through straightened stretches is a priority for a watershed steering committee picked by the public at a meeting in La Jara in March, 1995. This meeting kicked off the Alamosa River Watershed Project which is sponsored by the Conejos County Soil Conservation District. The 13-member committee consists of local landowners, water users and government officials.

In addition to tackling erosion issues, the steering committee is seeking watershed-wide solutions to water quality problems, noxious weeds and economic concerns.

The watershed committee plans to install two projects that demonstrate techniques to stabilize the river and restore riparian habitat in the summer of 1996.

## EROSION WORSENERD OVER TIME

After portions of the Alamosa River were straightened in the early 1970s, a chain of calamitous

events was set in motion. First, the river developed a steeper gradient. This caused the velocity of the water to increase.

Where flows once were slowed as the river wound its way through meanders and oxbows, water ripping through straightened areas began to erode stream banks and dig a deeper channel. Water tables dropped, de-watering adjacent riparian areas and wetlands.

Today, a quarter century later, the river channel has been lowered so much in places that stream banks resemble canyon walls. Irrigation headgates are useless because they now are perched several feet above the water, even during high flows.

Water users spend thousands of dollars each year in an effort to prop up failing diversion structures and move water into their headgates for one more growing season. The county government expends scarce resources to protect adjacent roads and bridges.

## CURRENT PLANS

Late in 1995, the watershed steering committee identified two critical, highly-visible sites as potential locations for installing demonstration projects. At each site, the unstable river threatens irrigation diversion structures, and county roads and bridges. In addition, riparian areas at the two proposed sites are in poor condition.

Several river restoration experts have toured the river, met with the steering committee and given lectures to the public at meetings in Alamosa and La Jara.

Interest in restoring damaged rivers is keen in the San Luis Valley. Water users and officials from around the Valley have attended watershed committee-sponsored educational events and are keeping a close eye on developments along the Alamosa River.

Plans call for hiring two consultants to oversee the construction of the two demonstration projects. Dave Rosgen of Wildland Hydrology Consultants in Pagosa Springs, Colorado, will coordinate one project. Don Reichmuth, Geomax, Spokane, Washington, will supervise the other project.

The consultants use different designs in constructing rock drop structures. These structures deflect flows from vulnerable stream banks and dissipate the water's energy

by creating a controlled, stair-step drop in the river. The watershed committee wants to assess the different approaches before embarking on restoration of the entire straightened portion of the river.

Both consultants and the watershed committee realize restoring a healthy plant community along stream banks is vital to the long-term success of erosion control efforts. The combination of slower flows and management of livestock in riparian meadows should raise water tables and encourage the growth of a healthy plant community.

Landowner permission to install the demonstration projects has been attained. The Rio Grande Water Conservation District, Alamosa-La Jara Water Conservancy District, Conejos County, Gabino-Gallegos Ditch Company and Conejos County Soil Conservation District have already pledged support. Additional sponsors are being sought.

## CONCLUSION

Addressing problems in the 127,000-acre Alamosa River watershed is a daunting task. The steering committee for the Alamosa River Watershed Project has made restoring portions of the river destabilized by channelization a high priority.

Plans are on track to install two projects demonstrating erosion-control techniques in the summer of 1996. These demonstration projects not only will show the use of structures built in the stream channel to protect erosion-threatened banks and headgates, they will also demonstrate methods for restoring adjacent riparian areas.

After construction, the demonstration projects will be monitored to assess their effectiveness as the watershed steering committee considers strategies to stabilize the Alamosa River throughout the entire straightened reach.



# GEOLOGICAL CHARACTERISTICS OF THE SUMMITVILLE MINE AND THEIR ENVIRONMENTAL IMPLICATIONS

John E. Gray and Geoffrey S. Plumlee  
U.S. Geological Survey, P.O. Box 25046, MS 973, Denver, Colorado 80225



## INTRODUCTION

The Summitville mine, located in the southeastern San Juan Mountains of southwest Colorado (Fig. 1), has received considerable attention as a result of environmental problems related to mining activities. Summitville Consolidated Mining Company, Inc. (SCMCI), a subsidiary of Galactic Resources of Canada, operated an open-pit gold mine at Summitville (Fig. 2) during the period from 1985 to 1992. Environmental remediation was underway by SCMCI when the mine was abandoned in December, 1992, and SCMCI declared bankruptcy. The Environmental Protection Agency (EPA) took over the mine site under Superfund Emergency Response authority, and intensified remediation efforts. Summitville was added to the Superfund National Priorities List in May, 1994. The EPA continues to monitor the site and treat acid- and metal-rich waters emanating from the mine. The EPA has plugged the major acid-mine drainage sources (the Reynolds and Chandler adits), and has moved several waste piles back into the open pit including the Cropsy waste dump, Beaver mud dumps, and Cleveland Cliff tailings. Cyanide solutions in the heap leach pad were also treated by the EPA.

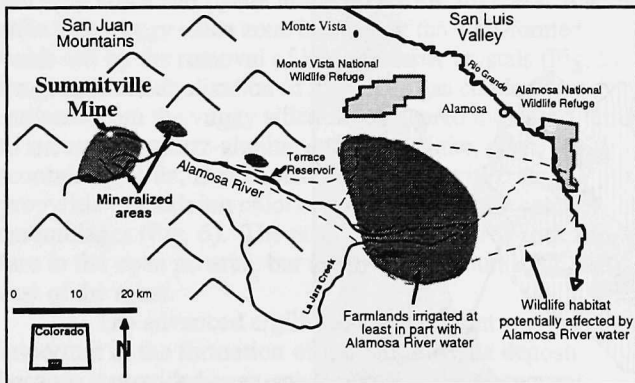

Figure 1. Location of the Summitville mine, Alamosa River, and adjacent San Luis Valley, SW Colorado.

Concerns remain about the possible short- and long-term adverse effects to the environment resulting from the abandoned mining operations. Geologic characteristics

of the Summitville mine are an important control on the generation of acid drainage, the dominant long-term environmental problem at the site. A thorough understanding of the environmental geology of the Summitville gold-silver-copper deposit is necessary to: (1) develop the most effective remediation strategies for the Summitville site, and (2) help predict, mitigate, and remediate potential environmental problems at future proposed mine sites with similar geologic characteristics. This paper summarizes the geologic characteristics of the Summitville mineral deposit and their effect on the environment. Most of the conclusions in this paper were drawn from Gray et al. (1994) and Plumlee et al. (1995a). Additional geologic descriptions of Summitville are provided in Steven and Ratté (1960), Perkins and Nieman (1982), Stoffregen (1985; 1987), Gray et al. (1993), and Gray and Coolbaugh (1994).

## GEOLOGIC CHARACTERISTICS

The processes that formed the gold-silver-copper deposit at Summitville also directly relate to the generation of both natural and mining-related acid drainage from the site. Summitville is located in the southeastern portion of the mid-Tertiary San Juan volcanic field, a thick section of volcanic rocks composed in its lower portions of andesitic volcanics and related rocks erupted from numerous stratovolcanoes, and in its upper portions of andesitic to rhyolitic ash flow sheets erupted from numerous calderas (Steven and Lipman, 1976).

### South Mountain Volcanic Dome

The Summitville deposit is hosted by the South Mountain volcanic dome (Figs. 3, 4) and formed about 22 million-years ago as a direct result of the magmatic processes that generated the dome (Steven and Ratté, 1960; Perkins and Nieman, 1982; Stoffregen, 1985, 1987; Rye et al., 1990; Gray and Coolbaugh, 1994). The volcanic dome is composed of quartz latite lavas that contain abundant silica and coarse grained crystals of feldspar. The quartz latite lavas were extruded from a narrow feeder zone



Figure 2. Aerial view of the Summitville mine in 1991 looking southwest (photo by IntraSearch, Inc.)

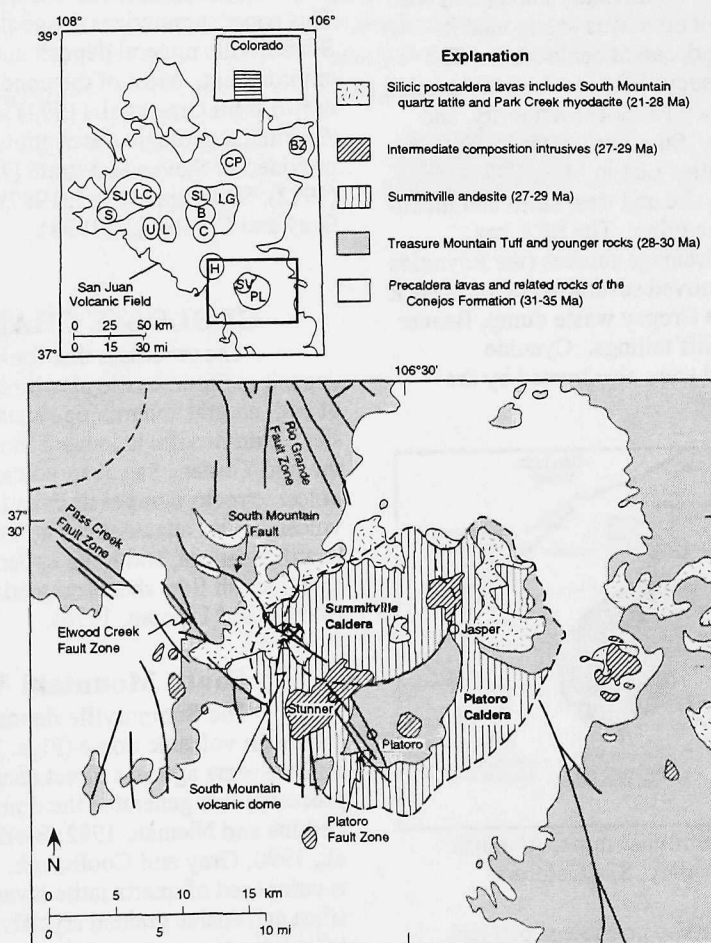

Figure 3. Location map showing the outline of the San Juan volcanic field and calderas within the field (generalized from Lipman, 1975). Age data are from Steven et al., (1967), Lipman et al. (1970), Lipman (1975), Mehnert et al. (1973), and Perkins and Nieman (1982). Calderas shown are abbreviated: B-Bachelor, BZ-Bonanza, C-Creede, CP-Cochetopa Park, H-Mount Hope, LC-Lake City, LG-La Garita, L-Lost Lake, PL-Platoro, S-Silverton, SJ-San Juan, SL-San Luis, SV-Summitville, and U-Ute Creek. Inset figure geology modified from Lipman (1975) and Steven and Lipman (1976). X - Location of the Summitville deposit. Reprinted from Gray and Coolbaugh (1994).

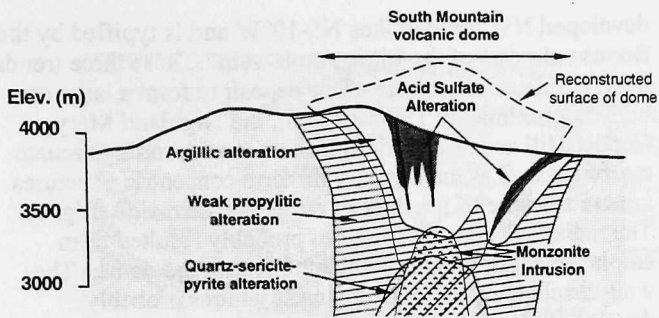

Figure 4. Generalized cross section of the South Mountain volcanic dome showing the geology and distribution of altered rocks. Modified from Perkins and Nieman (1982) and Enders and Coolbaugh (1987). Reprinted from Plumlee et al. (1995a).

(Steven and Ratté, 1960) and pushed outward to form a typical mushroom-shaped silicic lava dome (Fig. 4). Rocks along the contact between the dome lavas and surrounding andesitic lavas were brecciated, creating a zone of higher permeability that is an important control on groundwater movement at the site.

### Formation of the Summitville Deposit

As part of the volcanic dome-forming process, additional magmas were intruded into the area beneath the dome. As these magmas crystallized, they released hot gases rich in sulfur dioxide. The gases rose along fractures in the quartz latite volcanic dome and eventually condensed in the upper portions of the dome, producing fluids rich in sulfuric acid that extensively leached and altered the quartz latite to an advanced argillic alteration assemblage (Fig. 4). The greatest amounts of leaching resulted near fractures and left only silica and pyrite in the rock; this alteration zone is called the vuggy silica zone because of the well-formed voids left by the removal of large feldspar crystals (Fig. 5). Progressive neutralization of the acidic gas condensates outward from the vuggy silica zones altered the quartz latite to successive quartz-alunite, quartz-kaolinite, clay (containing illite, montmorillonite, and pyrite), and propylitic (containing chlorite, pyrite, and some calcite) assemblages (Fig. 6). The propylitically altered rocks are rare in the open pit area, but are more common south and east of the mine.

The advanced argillic alteration event was important in the formation of the Summitville deposit because it provided open-space porosity for subsequent sulfide and gold deposition. The advanced argillic rocks are also environmentally significant because these rocks have a greatly reduced capacity (as compared to fresh, unaltered quartz latite) to consume acid in natural and mine drainage. Propylitically altered rocks contain minor amounts of carbonate minerals that can help neutralize acid water; however, the propylitically altered rocks are in such small amounts in the Summitville open pit that they likely have

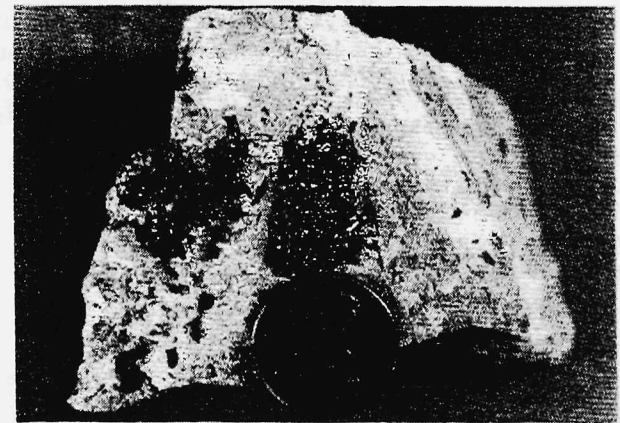
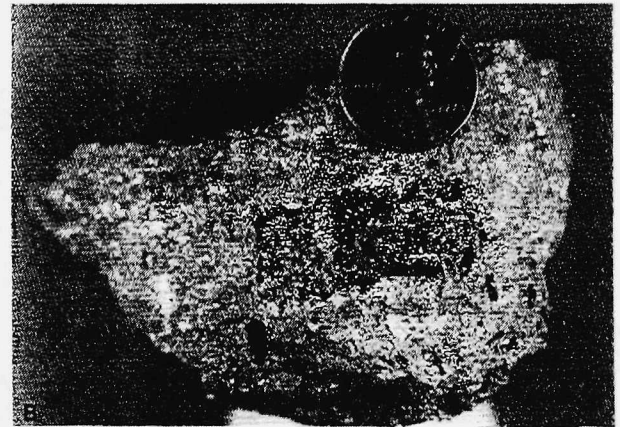
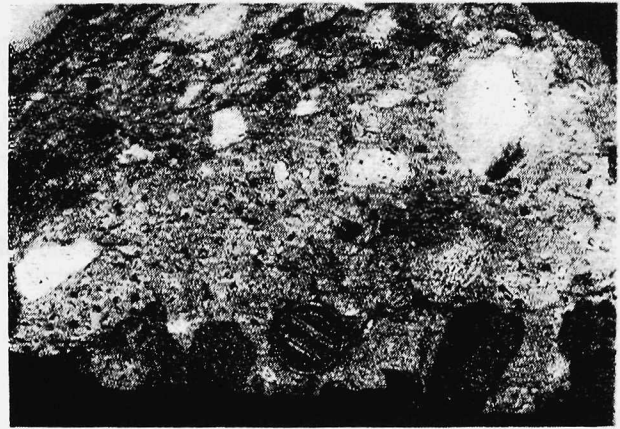

Figure 5. Photos showing pyrite (A and B) and enargite (C) replacing feldspar phenocryst sites in vuggy silica from the Summitville deposit. Sulfide minerals in unoxidized ore zones are responsible for generation of most of the acid waters. From Gray et al. (1994).

had relatively little mitigative effect on acid-mine drainage at the site.

Following the period of intense acid leaching by magmatic gas condensates, Cu- and As-rich sulfide minerals were deposited in the highly altered rocks by hot hydrothermal fluids (about 100-250° C) also derived from crystallizing magmas below the Summitville deposit. Minerals deposited in this assemblage include pyrite,

marcasite, enargite, native sulfur, covellite, chalcopyrite, tennantite, and minor barite, sphalerite, galena, and various phosphate minerals (Stoffregen, 1987; Gray and Coolbaugh, 1994). The greatest amounts of sulfide minerals (generally 1-5 %) are found in rocks altered to vuggy silica and quartz-alunite (Fig. 6) because hydrothermal fluid flow was focused in these highly permeable zones; however, appreciable Cu-As sulfide minerals were also deposited in the other alteration zones. During the final stages of the formation of the mineral deposit, several hydrothermal breccias were generated, in which magmatic fluids were explosively released from depth into the volcanic dome; these breccias also contain minor sulfide minerals. Finally, late-stage sulfide-rich veins were deposited in fractures cutting the highly altered rocks (Gray and Coolbaugh, 1994).

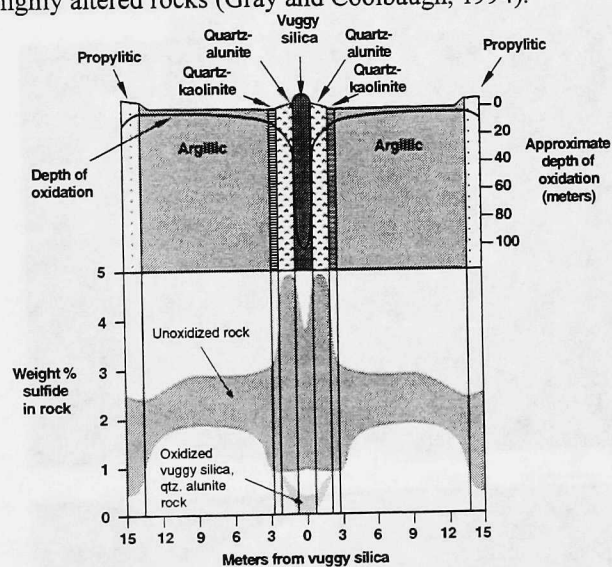

Figure 6. Generalized alteration zoning along from fractures in the South Mountain quartz latite, showing approximate depth of oxidation (upper plot) and ranges of reduced sulfur in weight percent (lower plot). From Plumlee et al., 1995a), based on data from Gray et al. (1994).

### Structure

The importance of structures as controls on the distribution of alteration and mineralization zones is illustrated by a map of gold grades of the Summitville mine (Fig. 7); the highest gold grades generally follow the vuggy silica zones of most intense alteration. Vuggy silica zones and coincident gold ore zones radiate outward from the core of the deposit (Enders and Coolbaugh, 1987; Fig. 7). Three northwest fracture trends are present that dip steeply from 65° to vertical. A N30°W ± 20 trend is typified by narrower zones with higher Au grades, such as the Little Annie and Tewksbury zones. A second strong NW structural trend is characterized by N60°W zones that are wider and longer, but have lower than average Au grades; examples are the Highland Mary, Nellie, and Copper Hill zones; these N60°W zones parallel the South Mountain fault on the southwest side of the deposit. A third, less well-

developed NW trend strikes N5-10°W and is typified by the Bonus vein east of the Little Annie vein. These three trends intersected near the center of the deposit to form a large ore body approximately 150 by 400 m, the Highland Mary-Copper Hill zone. In addition, some west-trending arcuate ore zones such as the Dexter vein form concentric structures around the core of the deposit on its northern side (Fig. 7). The radial and arcuate structures probably resulted from emplacement of magmas at depth beneath the dome. The well-developed, N60°W-trending structures probably developed along pre-existing regional fractures that were reopened during the Summitville alteration and mineralization.

In summary, original dome structures focused alteration by magmatic gas condensates. The alteration zones and some later cross-cutting structures have, in turn, greatly influenced post-mineralization groundwater movement and the extent of weathering prior to mining.

## ENVIRONMENTAL GEOLOGY

A fundamental environmental concern at Summitville is the presence of abundant sulfide-bearing rocks with the potential to generate highly acidic and metalliferous waters during surface weathering (Fig. 5). Geologic units of environmental concern are all sulfide-bearing rocks (primarily pyrite, marcasite, and enargite) including the highly permeable vuggy silica zones, quartz, alunite and quartz kaolinite zones, and argillic rocks. Volumetrically minor late-stage sulfide-rich veins and hydrothermal breccias are also important, but are considered insignificant acid-generators in comparison to the large volumes of sulfide-bearing vuggy silica, quartz-alunite, quartz-kaolinite, and argillic rocks. Open-pit mining exposed large volumes of sulfide-bearing rocks to weathering. When these rocks weather, the sulfide minerals are oxidized forming sulfuric acid, which then leaches metals from the surrounding rocks, primarily from the sulfide minerals. There is little carbonate or fresh rock to buffer (or neutralize) any acid-rich solutions generated during weathering. Components of environmental concern are rocks in the open pit, heap-leach pad, waste piles, and geologic structures in and around the mine site (Fig. 8). The interaction between these rocks and surface and groundwaters is also important for understanding environmental problems.

### Open Pit

The primary environmental problem related to the open pit is the formation of acid- and metal-rich waters. Most of these waters emanate as acid-mine drainage from small seeps in and around the open pit, and larger volumes of effluent from mine adits connected to underground workings, such as the Reynolds adit. Adits and underground workings located at Summitville were

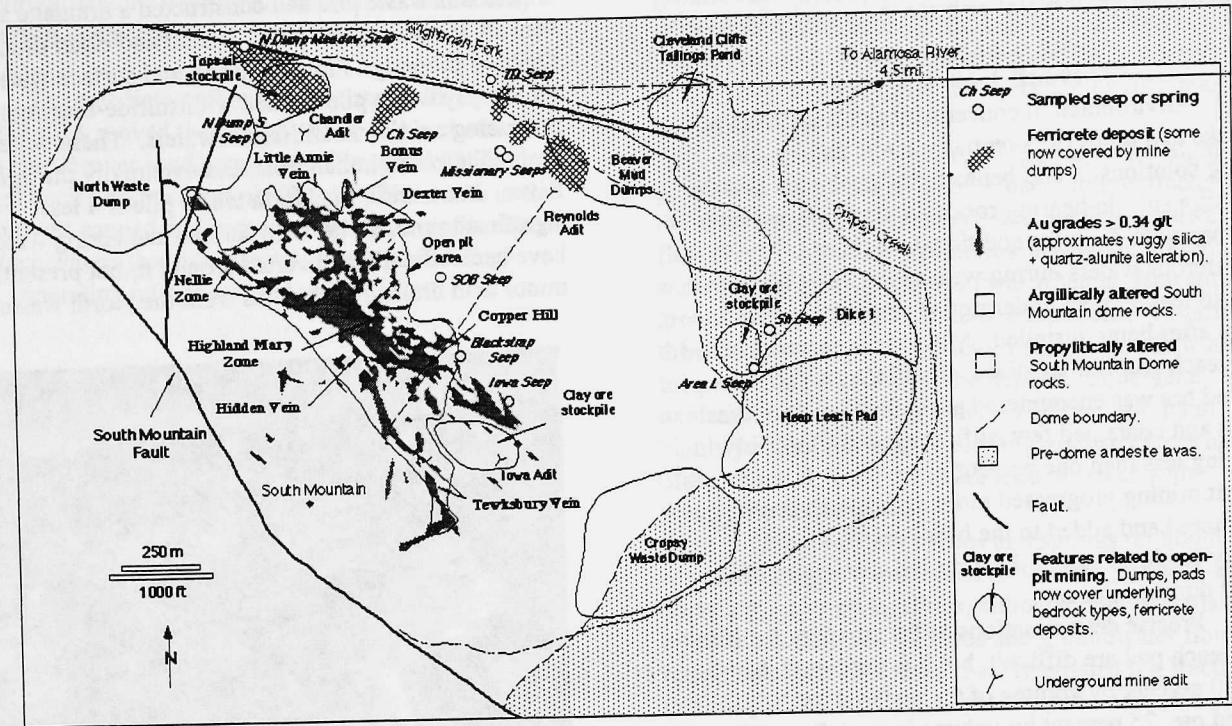

Figure 7. Generalized map of the Summitville mine site showing geologic features (major alteration and ore zones, ferricrete deposits) in relation to past and recent mine features. Also shown are the locations of active seeps sampled for ferricrete deposits (some now covered by mine dumps). The distribution of argillic and propylitic alteration was taken from a surficial geologic map prepared by Mike Perkins and Bill Nieman for the Anaconda Company in the early 1980's. The distribution of acid sulfate alteration (vuggy silica and quartz alunite zones) is approximated by gold grades greater than 0.34 grams per ton (after Gray and Coolbaugh, 1994). The location of ferricrete deposits is approximate based on distributions observed in aerial photographs taken of the site in 1968 and 1980 by Intra-Search, Inc; many of the deposits are now covered by material from the recent open pit mining operations. Figure from Plumlee et al. (1995a).

developed during early underground mining of high-grade gold zones in the late 1800's and early 1900's (Steven and Ratté, 1960). Acid-mine drainage emanated from the Reynolds adit prior to open-pit mining, but the acidity and metal loadings increased after open-pit mining began (Plumlee et al., 1994).

Formation of metal-rich secondary salts in the open pit and throughout the mine site is also a potential environmental problem because such salts may release metal into surface water when they dissolve (Flohr et al., 1995). Minor pools and puddles of acidic and metalliferous water were observed in the open pit and as these acid waters evaporate during dry periods, they precipitate a complex suite of soluble secondary salts that contain metals and acid in solid form until they dissolve during the next period of rain or snowfall (Plumlee et al., 1995b). Secondary salts were found as surficial coatings on rocks within the open pit and waste dumps, as coatings on fractures in rocks of the open pit walls, and as disseminations within sediments throughout the mine site

(Flohr et al., 1995; Plumlee et al., 1995a). In the area beneath the pit, these salts are abundant near airways that allow for evaporation, such as in and near mine workings and in fractured rock immediately beneath the open pit. Soluble secondary salts are a significant environmental concern at Summitville due to their abundance and the ease with which they can liberate metals and acid into the environment simply by dissolving in surface water.

To remediate environmental problems in the open pit, the SCMCI initiated, and later the EPA continued, reducing the amount of acid-mine waters draining into the Wightman Fork of the Alamosa River by treating some of the waters emanating from the Reynolds adit, and then releasing waters with improved water quality. The EPA then plugged the Reynolds and Chandler adits in 1994, eliminating acid-mine drainage from these sources, which were the major effluents at the mine. In 1995, the EPA filled the open pit with material from several waste piles at the mine site in order to reduce surface oxidation and acid water production in the

open pit. Filling the open pit also reduced the potential for the formation of metal-rich secondary salts in the pit.

### Heap Leach Pad

Environmental concerns of the heap leach pad are leaks and seeps of potentially acidic and cyanide-bearing solutions in and beneath the leach pad, and the remaining sulfide-bearing rocks on the leach pad with the capacity to generate additional acidic and metalliferous waters during weathering. The leach pad began to leak into an underground drainage system shortly after being installed. Most of the material added to the leach pad was oxidized, silicified ore. This oxidized ore was encountered at shallow levels of the deposit and contained few sulfide minerals, probably averaging less than one percent by volume. However, as open-pit mining progressed more sulfide-rich ore was encountered and added to the heap leach pad. Some partially oxidized sulfide-bearing ore also was added to the pad during mining.

Precise determinations of the amount of sulfide on the leach pad are difficult, but it is estimated that about 70 percent by volume of the material on the pad is oxidized ore, 25 percent by volume is partially oxidized sulfide-bearing ore, and 5 percent by volume is unoxidized sulfide-rich ore. Therefore, total sulfides in the material on the leach pad probably do not exceed one percent by volume. However, because there is little buffering capacity in the material on the leach pad, rocks contained on the leach pad could generate significant acid during weathering. Conventional agglomeration of ore using lime and cement was not carried out at Summitville. Lime was added to ore as it was added to the leach pad as a pH control of the cyanide solution. This lime may increase the buffering capacity of the heap leach pad, but its long-term buffering capacity is presently unknown.

To remediate environmental problems on the heap-leach pad, SCMCI captured and treated water leaking beneath the leach pad between 1986-1992. The EPA has continued to monitor, capture, and treat waters leaking from the heap leach pad, as well as detoxify cyanide remaining on the heap leach pad. The EPA is also evaluating a procedure to cap the heap leach pad to reduce the amount of surface water flowing into it, and thereby reducing potential acid-water generation from sulfide-bearing rocks located there.

### Waste Piles

Waste rocks at the Summitville mine site were located in the Cropsy and North waste piles (Fig. 8). Most environmental mine waste concerns were related to the Cropsy waste pile that was constructed in the relatively small Cropsy Creek, part of the larger Alamosa River (Fig. 1). The SCMCI diverted Cropsy Creek

around this waste pile and constructed a drainage system beneath the waste, but the diversion and drain did not function properly. Flow of spring and surface waters into the Cropsy waste pile reacted with sulfide-bearing rocks producing acidic, metalliferous waters. These waters drained into Wightman Fork and eventually the Alamosa River. In contrast, the North waste pile is a less significant problem because surface and spring waters have been effectively diverted around it, but presently, minor acid drainage emanates from the North waste pile.



Figure 8. Aerial view of the Summitville mine looking southwest showing open pit (A), heap leach pad (B), north waste pile (C), Cropsy waste pile (D), Reynolds adit (E), and Chandler adit (F) (photo by IntraSearch, Inc.). From Gray et al. (1994).

The majority of waste in the piles is sulfide-bearing and oxidized argillic rocks, with lesser breccia waste (also argillic), and propylitic rocks that are also typically sulfide-bearing. Argillic rocks contain about 2 to 3 volume percent sulfide minerals. Silicified rock was rarely mined as waste, but due to the small-scale nature of some silicified ore zones, as much as 10 volume percent of the waste piles may be silicified rock. Minor amounts (less than 1 volume percent) of sulfide ore minerals should be expected in the dump material due to the composition of the late-stage breccias (Gray and Coolbaugh, 1994) and because minor silicified ore material is in the piles. Similar to the open pit and heap-leach pad, the total amount of sulfide minerals in the waste piles is small; however, acidic waters can form rapidly because of the inability of surrounding rocks to buffer the solutions. As discussed for the open pit, formation of soluble salts in the waste piles also may be

an important factor affecting metal contents and acidity of waters in contact with waste material (Flohr et al., 1995).

To remediate problems associated with the waste piles, the EPA moved the Cropsy waste pile and other wastes (the Beaver mud dumps and Cleveland Cliffs tailings) back into the open pit (Fig. 7). The waste in the open pit was capped and contoured to reduce infiltration of surface waters that may react with sulfide-bearing rocks, generating additional acid waters.

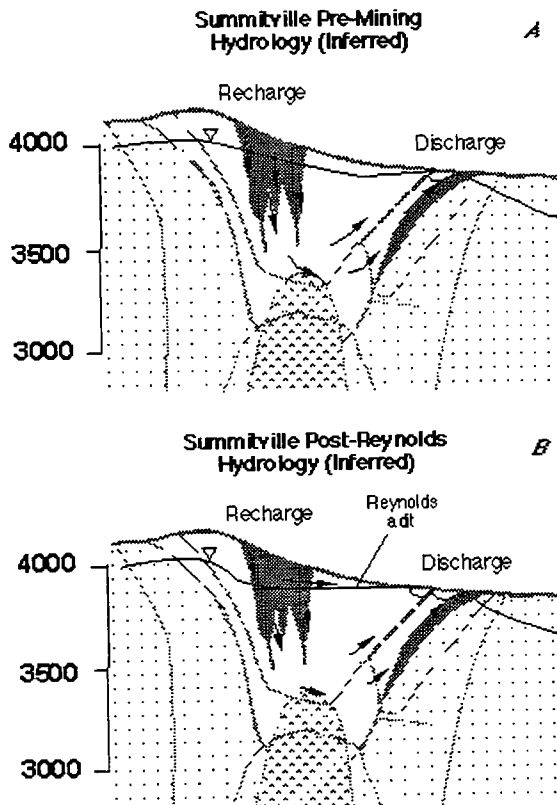

Figure 9. A. Generalized cross section showing inferred hydrology of the Summitville mine prior to underground mining. Solid black line with triangle indicate the water table. Arrows indicate possible groundwater paths. B. Generalized cross section showing inferred hydrology of Summitville resulting from underground mining. Solid black line with triangle indicate the water table. Arrows indicate possible groundwater paths. Flow was reduced from natural discharge points due to increased flow from the Reynolds adit. From Plumlee et al. (1995a).

### Structures

Fracture control is an important aspect of many ore deposits, including Summitville. Fracture control was not only important for localizing Summitville advanced argillic alteration and mineralized zones, but is also an important component affecting modern

groundwater hydrology (Fig. 9). The interaction between water and sulfide-bearing rocks along permeable fractures has led to acid-water generation and water-quality degradation and is an important environmental concern at Summitville.

Silicified rocks, most importantly the highly permeable vuggy silica zones, closely follow fractures in the open pit and significantly affect local groundwater flow (Fig. 9). During weathering highly metalliferous and strongly acidic solutions form when surface and groundwaters contact sulfide-bearing rocks, primarily in the more permeable ore zones. These waters flow along the permeable fractures in the deposit. Supergene oxidation to depths of as much as 100 m (300 ft) in highly permeable vuggy silica (Fig. 6) provides evidence of the importance of the interaction of water with permeable fractures.

The location of seeps and springs on South Mountain suggest a relationship between fractures and hydrology at some localities, although many details of the relationship between fractures and groundwater flow remain unresolved. Strong northwest-striking fractures that control the location of mineralized zones in the open pit also appear to control groundwater flow north and south of the ore deposit. A southerly extension of the Nellie-Highland Mary-Iowa zones probably controls the location of springs south of the open pit in Cropsy Creek.

Many ferricrete deposits in and around the mine indicate locations of past and present water seeps. Near the base of South Mountain and northwest of the open pit, a large iron bog or ferricrete deposit was found during drilling; this deposit is located at the projected intersection of the Little Annie vein and Missionary fault (Gray et al., 1993). The deposit is as much as 15 m (50 ft) thick, suggesting that iron-rich groundwaters had at one time passed through the Summitville deposit and surfaced as springs in this area. This area is presently concealed because it is overgrown with vegetation and did not appear to be actively seeping groundwater prior to plugging of the Reynolds adit. Smaller ferricrete deposits are located on the north slope of South Mountain near the Dexter adit, just outside the open pit. These deposits lie along an intersection of northeast-striking fractures in the open pit and the Dexter zone. The location of these seeps and ferricrete deposits suggests that these fractures have influenced groundwater hydrology and that acid drainage existed prior to any mining.

Underground mine workings significantly changed the groundwater hydrology. Adits, crosscuts, and drifts have likely diverted waters away from their normal prehistoric discharge points, possibly explaining why iron bogs northwest of the open pit are no longer active. At one time, the Chandler adit was clearly discharging water because a stand of dead trees and

ferricrete deposits are present near the adit. Prior to open-pit mining and plugging of the Reynolds adit, the Chandler adit was dry, but the younger and topographically lower Reynolds adit has a significant acid-mine drainage discharge, some of which has drained into the Wightman Fork of the Alamosa River (Fig. 1). It is possible that underground mining diverted groundwater flow from the Chandler to the Reynolds workings.

Throughout open-pit mining, acid waters continued to discharge from the Reynolds adit. The water quality of the Reynolds effluent had shown increased metal loadings (e.g. copper) as mining progressed (Golder and associates, 1992; Plumlee et al., 1994). The deterioration of the Reynolds effluent was probably a result of increased surface area exposure of sulfide-bearing rocks, and groundwaters flowing into different fractures. Many of the permeable, oxidized vuggy silica zones were removed as mining continued, resulting in flow of surface and groundwaters into new fractures that were generally less oxidized. In summary, fractures control groundwater flow in the open pit and outside its boundary. Underground workings intercepted these fracture-controlled groundwaters and diverted them to new discharge locations, the most significant of which was the Reynolds workings. Open-pit mining removed zones of oxidized vuggy silica, forcing waters to follow more sulfide-rich fractures, adding to water degradation. Therefore, fractures and underground workings affected the acid-mine drainage location and output. Some of the metal- and acid-rich effluent from Summitville drains into the Wightman Fork of the Alamosa River.

To slow seepage from the mine site, the EPA plugged the Reynolds and Chandler adits, which ceased discharge from these major sources of acid mine drainage, but effectively increased the water table elevation. Sealing these adits resulted in some additional leaks including seeps north of the open pit, along the Missionary fault, and along the volcanic dome contact east of the open pit. Although seep waters are highly acidic and metalliferous, overall the acid and metal concentrations in these seep waters have decreased significantly as a result of the EPA's remediation efforts; however, such seeps are a source of acid and metal that may require long-term monitoring and possibly treatment.

## CONCLUSIONS

Altered and mineralized rocks at Summitville contain relatively small amounts of sulfide minerals, generally less than 5 percent. Yet significant acid-mine drainage problems have resulted at Summitville primarily because the surrounding rocks were pervasively altered during hydrothermal processes forming highly

siliceous and argillized rocks with little capacity to buffer acidic waters generated during weathering. Concerns continue because altered and mineralized rocks in the open pit, heap leach pad, and waste piles are exposed to oxygenated waters during surface weathering and have long-term potential to generate additional acid- and metal-rich waters. Subsurface structural control and underground mine workings at Summitville also affect water quality and the location of acid-mine drainage output. Results from Summitville underscore the need for careful geologically constrained acid-generation studies of ore and altered rocks at all potential mine sites, a current practice that was overlooked at Summitville. Economic geology studies of mineralogy, structure, and alteration are a critical initial process in an environmental characterization of a mineral deposit. Thus, economic geologists can play an important role in understanding and predicting unique effects of various types of mineral deposits and resource development on surrounding environments.

## REFERENCES

- Enders, M.S., and Coolbaugh, M.F., 1987, The Summitville gold mining district, San Juan Mountains, Colorado, *in* Gee, W.R., and Thompson, T.B., eds., Gold mineralization of Colorado's Rio Grande Rift: Denver, Denver Region Exploration Geologists Society Fall Field Guidebook 19-20 Sept. 1987, p. 28-36.
- Flohr, M.J.K., Dillenburg, R.G., Nord, G.L., and Plumlee, G.S., 1995, Secondary mineralogy of altered rocks, Summitville mine, Colorado: U.S. Geological Survey Open-File Report 95-808, 27 p.
- Golder and Associates, 1992, Summitville mine reclamation plan: prepared for Summitville Consolidated Mining Company, Inc., Lakewood, Colorado.
- Gray, J.E., and Coolbaugh, M.F., 1994, Geology and geochemistry of Summitville, Colorado: an epithermal acid-sulfate deposit in a volcanic dome: *Economic Geology*, v. 89, p. 1906-1923.
- Gray, J.E., Coolbaugh, M.F., and Plumlee, G.S., 1993, Geologic framework and environmental geology of the Summitville, Colorado, acid-sulfate mineral deposit: U.S. Geological Survey Open-File Report 93-677, 29 p., 1 plate.
- Gray, J.E., Coolbaugh, M.F., Plumlee, G.S., and Atkinson, W.W., 1994, Environmental geology of the Summitville Mine, Colorado: *Economic Geology, Special Issue on Volcanic Centers as Exploration Targets*, v. 89, p. 2006-2014.

- Lipman, P.W., 1975, Evolution of the Platoro caldera complex and related volcanic rocks, southeastern San Juan Mountains, Colorado: U.S. Geological Survey Professional Paper 852, 128 p.
- Lipman, P.W., Steven, T.A., and Mehnert, H.H., 1970, Volcanic history of the San Juan Mountains, Colorado, as indicated by potassium-argon dating: Geological Society of America Bulletin, v. 81, no. 8, p. 2329-2352.
- Mehnert, H.H., Lipman, P.W., and Steven, T.A., 1973, Age of mineralization at Summitville, Colorado, as indicated by K-Ar dating of alunite: Economic Geology, v. 68, p. 399-401.
- Perkins, M., and Nieman, G.W., 1982, Epithermal gold mineralization in the South Mountain volcanic dome, Summitville, Colorado: Denver Region Exploration Geologists Symposium on the genesis of Rocky Mountain ore deposits: Changes with time and tectonics, Denver, Colorado, Nov. 4-5, 1982, Proceedings, p. 165-171.
- Plumlee, G.S., Gray, J.E., Roeber, M.M., Coolbaugh, M.F., Flohr, M., and Whitney, G., 1995a, The importance of geology in understanding and remediating environmental problems at Summitville: Summitville Forum Proceedings, Colorado Geological Survey Special Publication 38, p. 13-22.
- Plumlee, G.S., Ficklin, W.H., Smith, K.S., Montour, M., Gray, J.E., Hageman, P., Briggs, P.H., and Meier, A.L., 1994, Geologic and geochemical controls on the composition of acid waters draining the Summitville mine, Colorado [abs.]: U.S. Geological Survey, McKelvey Forum, 9th, Tucson, Arizona, February, 1993, U.S. Geological Survey Circular 1103-A, p. 78.
- Plumlee, G.S., Smith, K.S., Ficklin, W.H., Mosier, E., Montour, M., Briggs, P., and Meier, A., 1995b, Geochemical processes controlling acid-drainage generation and cyanide degradation at Summitville: Summitville Forum Proceedings, Colorado Geological Survey Special Publication 38, p. 23-34.
- Rye, R.O., Stoffregen, R., and Bethke, P.M., 1990, Stable isotope systematics and magmatic and hydrothermal processes in the Summitville, CO gold deposit: U.S. Geological Survey Open-File Report 90-626, 31 p.
- Steven, T.A., and Lipman, P.W., 1976, Calderas of the San Juan volcanic field, Southwestern Colorado: U.S. Geological Survey Professional Paper 958, 35 p.
- Steven, T.A., Mehnert, H.H., and Obradovich, J.D., 1967, Age of volcanic activity in the San Juan Mountains, Colorado, in Geological Survey research 1967: U.S. Geological Survey Professional Paper 575-D, p. D47-D55.
- Steven, T.A., and Ratté, J.C., 1960, Geology and ore deposits of the Summitville district, San Juan Mountains, Colorado: U.S. Geological Survey Professional Paper 343, 70 p.
- Stoffregen, R.E., 1985, Genesis of acid-sulfate alteration and Au-Cu-Ag mineralization at Summitville, Colorado: Berkeley, University of California, Ph.D. dissertation, 205 p.
- Stoffregen, R.E., 1987, Genesis of acid-sulfate alteration and Au-Cu-Ag mineralization at Summitville, Colorado: Economic Geology, v. 82, p. 1575-1591.



# THE MINING HISTORY AND ENVIRONMENTAL CLEAN-UP AT THE SUMMITVILLE MINE

By

Victor L. Ketellapper

United States Environmental Protection Agency (EPR-SR)

999 18th Street, Denver, Colorado 80202

EMAIL: ketellapper.victor@epamail.epa.gov

James A. Pendleton, Harry H. Posey and Mike B. Long

Colorado Department of Natural Resources, Division of Minerals and Geology

1313 Sherman Street, Denver, Colorado 80203



## INTRODUCTION

- (1) At 9:00 pm on December 1, 1992, Galactic Resources Limited (GRL) of Vancouver, Canada notified the State of Colorado of their intent to declare bankruptcy and abandon operation of the Summitville mine effective December 16.

The fluid level in the cyanide heap leach pad at that time stood just five feet below the emergency spillway and normal winter precipitation would have caused it to overtop the spillway. Had that happened, cyanide and metal-bearing processing fluid would have overflowed by February of the next year. Within hours of a power outage or mechanical failure, water pumps would have shut down, leaving acidic cyanide water in the heap leach underdrain effluent to overflow the underdrain sump. Effluent from the underdrain would have discharged directly into Cropsy Creek, then Wightman Fork, a tributary to the Alamosa River.

- (2) On December 4, with no capability to deal with an emergency of this character, the State requested emergency response assistance from Region VIII of the U.S. Environmental Protection Agency (EPA).
- (3) The EPA sent emergency response personnel and contractors to the site to assess the situation. Most of GRL's staff were retained by the EPA's contractors, the U.S. Bureau of Reclamation and Environmental Chemical Corporation, to facilitate the transition. Steps were taken to assure that necessary water circulation and water treatment

systems remained operable. Thus, the immediate threat of a direct contaminant release from the site was averted. A technical team comprised of EPA, DMG, and CDPHE personnel and emergency response personnel began assessing longer term consequences of GRL's operations.

For nearly eighteen months prior to bankruptcy, GRL and its daughter company Summitville Consolidated Mining Company Inc. (SCMCI) had been under constant State agency enforcement mandates to evaluate contaminant releases from the site and develop remedial measures to resolve the problems and reclaim the site. Also, state and federal agencies with varying regulatory responsibilities had been monitoring the mine site and its surroundings. As a result, though inadequate to answer the challenge, considerable environmental monitoring data were available with which to evaluate the Summitville Mine and its environmental impacts.

In the six months following GRL's abandonment of the site, a broad selection of environmental characterization, monitoring and clean-up projects were initiated. This paper describes the Summitville site, provides a history of the mining activities, and a description of the environmental clean-up approach.

## BACKGROUND

A general explanation of the physical situation, history, construction of the mine site, and on-site contaminant generation problems is provided in this section.

### Site Location and Description

The Summitville mining district is located about 25 miles south of Del Norte, Colorado, in Rio Grande County.

Occurring at an average elevation of 11,500 feet in the San Juan Mountain Range, the mine site is located two miles east of the Continental Divide. The mine pit occupies the northeastern flank of South Mountain (Figure 1). The permit area occupied by the State's Mined Land Reclamation permit covered 1440 acres, of which approximately 550 acres have been disturbed.

The Site is located in the Rio Grande Drainage Basin near the headwaters of the Alamosa River. The northern part of the Site is bounded by the deserted townsite of Summitville - last occupied in the mid-1930s - and by the Wightman Fork of the Alamosa River. Cropsy Creek, a tributary to Wightman Fork, bounds the site on the east. The confluence of Cropsy Creek and Wightman Fork is located near the northeastern perimeter of the site at the downstream boundary of the site. Wightman Fork enters the Alamosa River approximately 5 miles below its confluence with Cropsy Creek.

### **Climate**

The climate of the Summitville mine site is characterized by long cold winters and short cool summers. Snowfall is heavy (commonly 400 inches) and thunderstorms are common in the summer, particularly during the monsoonal season in August. Temperatures range from about 70°F to 17°F in summer and 40°F to -15°F in winter. Annual precipitation averages 55 inches, mostly as snowfall between November and April with annual evaporation of approximately 24 inches.

### **Topography**

South Mountain, the prominent topographic feature of the site, is a relatively steep-faced, faceted surface hosting sparse vegetation in the upper surfaces grading to a gently sloping alpine valley that forms the headwaters of the Wightman Fork. The oversteepened rock faces on South Mountain bear evidence partly of alpine glaciation and of rapidly eroding clay-rich rocks that break down readily in the local climate.

Before 1870, when gold was first mined from the Wightman Fork, the Site consisted of upland surfaces, wetlands and the peak of South Mountain. The predominant ground cover was alpine tundra at the higher elevations with coniferous forest and subalpine meadow in the lower elevations. Since then, mining has altered grossly the local topography. From 1870 through 1873 limited placer mining was conducted in the alluvial deposits of Cropsy Creek and Wightman Fork. Following that was limited open cut mining in several outcrops of gold-bearing quartz veins. From 1873 through 1940 the northeastern flank of South Mountain was mined extensively during several underground mining campaigns. To access the underground, the surface became laced with

road cuts and was disturbed by deposition of waste rock in downslope piles near adit portals.

Several mills were constructed at the mine site, including stamp mills and a flotation-cyanidation mill in 1934. Tailings were deposited downslope of each mill. In the late 1960's Wightman Fork was diverted to the north side of the stream valley to accommodate construction of a large tailings pond. Mill tailings at that time were deposited largely on what was to be called later the Beaver Mud Dump, just upslope of the tailings pond, and fine "slimes" were discharged to the pond (Figure 1).

Starting in 1984, SCMCI significantly altered and enlarged the pre-existing disturbed surface over most of the mine site. Waste rock and ore were excavated to form an open pit on the northeastern flank of South Mountain and were dumped into waste rock piles or placed onto a pad for heap leaching. Waste rock from the pit and other locations was used to construct the extensive road system, various building pads, parking lots, sediment ponds, and the earthen embankment that now contains the valley-fill heap leach pad (Dike 1). Cropsy Creek was diverted into a constructed channel upslope of the heap leach pad along the southeastern valley wall of the Cropsy Creek valley. Waste rock and fines were deposited on the Cropsy Waste Pile, the North Waste Pile, the Beaver Mud Dump and the Clay Ore Stockpile.

Several deviations from the original mining plan caused disturbances that might have been avoided. The original mining plan called for the processing of two separate types of ore: clay ore and vuggy silica ore. A separate crusher and conveyor system was installed for each of these ores. The clay ore was to have been agglomerated and leached on a pad upslope of the main heap leach pad, on what is now the Cropsy waste rock dump. However, agglomeration was abandoned, the experimental clay "ore" stockpile remains on the site, and the clay ore crusher and conveyor went virtually unused.

### **Geology**

The Summitville mining district is located near the margin of the Platoro-Summitville caldera complex. Ore-bearing rocks in the immediate area of the mine site consist of the South Mountain Quartz Latite Porphyry (Steven and Ratté, 1960). The porphyry is underlain and surrounded by the Summitville Andesite. The contact between the latite and andesite is intrusive, faulted in some areas, and nearly vertical. The contact on the northern margin of the latite intrusive is marked by the Missionary Fault. South Mountain is bounded on the southwest by the South Mountain Fault, a large northwest trending regional fault. The South Mountain Quartz Latite Porphyry is bounded to the west, on both sides of the South Mountain Fault, by the slightly older Park Creek Rhyodacite. The latite is overlain

at higher elevations in nearby erosional remnants by the Cropsy Mountain Rhyolite.

Emplacement of the South Mountain volcanic dome, hydrothermal alteration, and mineralization occurred in rapid succession approximately 22.5 million years ago (Rye and others, 1990). Stoffregen (1987) concluded that magmatic, hot and highly acidic, sulfate-laden water that suffused from the quartz latite magmas caused extensive alteration of the quartz latite. Hydrothermal alteration consists of four zones, generally occurring in sequence: vuggy silica, quartz-alunite zone, quartz-kaolinite zone, and the clay alteration zone. The vuggy silica zone generally is a porous unit from which most major elements except silica and iron were leached by acidic solutions and replaced in places by excess silica. This zone is comprised of irregular pipes and lenticular pods that generally show greater vertical than lateral continuity. The next outwardly occurring zone, the quartz-alunite zone, contains feldspars of the quartz latite porphyry which have been replaced by alunite. This zone grades outward to a thin quartz-kaolinite zone, which is not always present, and then into an illite-montmorillonite-chlorite zone in which feldspar and biotite crystals were replaced by illite and quartz, with lesser kaolinite and montmorillonite. The quartz-alunite and clay alteration zones are the most volumetrically significant. Fine-grained pyrite is disseminated through the groundmass in all zones (Rye, et al., 1990). Overall, the alteration mineralogy at Summitville is most similar to alteration near the crest of Cropsy Peak, a lava-capped peak southeast of South Mountain.

Summitville mineralization is an example of acid-sulfate epithermal Au-Ag-Cu mineralization associated with advanced argillic alteration (see Plumlee and others, 1995). Magmatic water (derived from the magma) mixed with the less acidic and more reducing meteoric water (derived from snowmelt and rainfall), and deposited metal sulfides at relatively shallow depths (less than 1 kilometer). Mineralization is associated mostly with the porous vuggy silica zone, and occurs as covellite + luzonite + native gold changing with depth to covellite + tennantite (see Plumlee and others this volume for an explanation of these minerals). Gold also occurs in a near-surface barite + goethite + jarosite assemblage that crosscuts the vuggy silica zone (Stoffregen, 1987). Numerous minerals comprised of secondary metal salts occur throughout the fractures and groundmass (Plumlee and others, 1995).

Post-volcanic geologic processes have been largely erosional, in part glacial. The two major streams that drain the site, Cropsy Creek and Wightman Fork, tend to follow the quartz latite/andesite contact. Numerous springs and seeps issue along this junction between the fractured quartz latite porphyry aquifer and the underlying dense andesite aquitard. Discharges of iron-rich waters from these springs and seeps, when mixed with air, form ferricrete bogs,

concrete-like deposits of iron oxides and iron hydroxides that cement together whatever lies in the path of the mineral water including rock, vegetation, and rarely, wildlife. Site cover material consists of topsoil, silt, clay, and gravel.

## **Hydrogeology**

Ground water at the Summitville mine site is present in several local, shallow, discontinuous perched aquifers. Shallow ground water occurs in surficial deposits consisting of colluvium, "slope wash" alluvium and/or glacial ground moraine, and weathered and fractured portions of the Summitville Andesite. These shallow systems discharge to surface water seasonally. The upper perched aquifer system also contributes to the ground water recharge of the fractured bedrock system. Both the quartz latite and andesite bedrock throughout the mine site are fractured extensively. Several local highly productive wells were installed apparently in zones of high fracture density, and are coincident with surface lineaments. Numerous springs and seeps occur throughout the mine site, the greatest number near the contact zone between the productive, upgradient quartz latite and the surrounding less permeable andesite. Most of these discharge in direct response to the annual precipitation cycle, with high and low flows corresponding to the surface water flows in the area. Rainstorm related discharges, particularly in August, occur at some seeps.

## **Surface Water Hydrology and Human Occupation**

Surface water from the Summitville Site flows past the town of Jasper into Terrace Reservoir, approximately 17 miles downstream from the confluence of the Wightman Fork with the Alamosa River. Below the Terrace Reservoir, the river flows into the western side of the San Luis Valley, past the town of Capulin. Throughout this drainage area, homes, farmsteads and ranches depend on alluvial and bedrock wells or river water for potable and agricultural water production. Additionally, the Alamosa River is used for surface irrigation on lands within a small portion of the Alamosa River Wildlife Refuge. Part of the Alamosa River is diverted through the Empire Canal into La Jara Creek. La Jara Creek stream flow and irrigation return water reach the Rio Grande River during several times of year. However, because of irrigation diversion and recharge loss to the alluvial aquifer, the Alamosa River channel rarely has in-channel flow east of U.S. Highway 287, so it does not flow into the Rio Grande at their historic confluence. In places the historic Alamosa River channel has been plowed.

## **Present Surrounding Land Use**

The Summitville Mine occurs mostly on private (patented) land, and is surrounded by lands of the Rio Grande National Forest. Within the mine site are 22 acres of Forest Service land. The Forest Service lands are highly desirable for outdoor sports and recreation, both in winter and summer. Additionally, logging is conducted adjacent to the site and the main access roads. Cattle and sheep are grazed in the surrounding area during summer and autumn the area is heavily hunted.

## **Production of the Summitville Gold Resource**

Placer gold was first discovered in the alluvium of the Wightman Fork of the Alamosa River by J. L. Wightman in 1870. In 1873 the first lode gold deposits were located and claimed on South Mountain. Like many mining communities in the west that are now ghost towns, Summitville materialized overnight to accommodate the miners who worked the mines and mills on South Mountain. Between 1873 and 1949, Summitville yielded approximately 240,000 troy ounces of Gold, worth approximately \$7 million at the time of production. Between 1950 and 1984, activities at Summitville were limited largely to exploration. Between 1984 and 1992, SCMCI produced approximately 249,000 troy ounces of Gold. Based on an average price of \$325 per ounce, this production represents a value of approximately \$81 million. (The price of gold fluctuated during mining operations and what SCMCI recovered in value is not known.)

## **GRL's Operating Problems**

In 1984, GRL acquired the property, completed additional drilling, and proceeded to obtain a permit for a "limited impact" test pit and heap leach. (A limited impact operation, in terms of the Mined Land Reclamation Board, covers less than 10 acres of disturbance and can disturb no more than 70,000 tons of rock per year.) The test project was completed in the summer and fall of 1984 and pronounced a success. GRL formed a local subsidiary, Summitville Consolidated Mining Company Inc. (SCMCI), in early 1984. SCMCI was a wholly-owned subsidiary of Galactic Resources, Inc. (GRI), of Idaho, which was in turn a wholly-owned subsidiary of Galactic Resources, Limited (GRL) of Canada. For simplicity hereafter, we will refer to GRL, the parent corporation, when referring to any of the three corporate entities.

GRL obtained a mine permit for the full scale open pit and heap leach operation in October 1984. However, the depressed gold price during 1985 apparently prolonged the raising of investment capital. Construction commenced in 1985, continued through the winter of 1985, and was completed during the summer of 1986. Considerable

difficulty was encountered during construction, due to the extreme winter conditions at the site, and this resulted in extensive avalanche damage to the heap leach liner system.

Even though SCMCI produced a reported 249,000 troy ounces of gold, the company's December 4, 1992 U.S. bankruptcy petition reported a net operating loss of approximately \$85 million. Complemented by equally unprofitable involvements in the Ridgeway (South Carolina) and Ivanhoe (Nevada) gold mines, Galactic Resources Limited of Vancouver, Canada, SCMCI's parent, reported a combined net operating loss of \$297 million in its January 21, 1993 Canadian bankruptcy petition.

SCMCI notified the State of its intention to file for Chapter VII bankruptcy petition by facsimile delivery of a draft press release at 9:00 pm on December 1, 1992. The press release stated that SCMCI intended to seek protection of bankruptcy because it lacked the financial ability to continue operations at the Summitville Mine after December 15, 1992. On the previous day, SCMCI had delivered a revision to their mined land reclamation plan that had been required by the Division of Minerals and Geology (the Division) and the Mined Land Reclamation Board (the Board). This revision application included cost estimates covering several amended reclamation plans; these ranged from \$20.6 and \$38.6 million. Upon completion of a technical adequacy review, the Division, as statutorily mandated, would have required the operator to submit additional warranty, increasing the bond to an amount equal to the projected reclamation cost. SCMCI filed its petition with the federal bankruptcy court in Denver on the afternoon of December 3, 1992.

## **ON-SITE CONTAMINANT SOURCES**

### **The Heap Leach**

Crushed ore was first deposited in the heap leach, and cyanide solution application commenced in June of 1986. During the first month of processing, cyanide-bearing fluids were detected in the leak detection layer between the primary fabric liner and the secondary compacted clay layer and in the underdrain installed beneath the secondary compacted clay liner. The Division of Minerals and Geology (the Division) reported the loss of containment to the Mined Land Reclamation Board (the Board). GRL and its consultants attributed both occurrences to sloppy application of solution which allowed overspray outside the partially lined basin. In addition, GRL presented the rationale that the leak detection system is also an interceptor system because no 45-acre heap could be constructed with zero leakage. The company was allowed to construct a sump (the French drain sump) to capture the contaminated leak detection and underdrain effluent and pump them back into the heap for containment.

The original permit application included a water balance assessment for the Summitville site that projected an excess of evaporation over precipitation. Had that been the case, water from Wightman Fork would have been needed to sustain operation of the heap leach. In fact, water rights covering this project were procured prior to operations. But the water balance projection was later determined to be in error. GRL's consultants contended that the sump fluid, which was pumped back to the heap, would not eliminate the projected water balance deficit within the heap. Additional water would still be required to compensate for evaporative loss.

Records from mid-1987 through the late fall of 1992 show that Summitville mine operations suffered a series of broken pump back pipelines and springs erupting from beneath the heap leach, resulting in releases of cyanide-contaminated fluids. One of the reasons that pumps failed is that acidic waters, which flowed beneath the heap leach pad into the French drain sump had to be neutralized prior to pumping. However, because lime was used to neutralize the acid, and because the solutions dissolved the metals in the pumps quickly, several pumps failed before the operator switched over to sodium hydroxide and stainless steel pumps for more stable operations.

Violations were issued and abatement actions ordered and completed only to encounter further setbacks. The NPDES/CDPS program's original assumption that the mine would be a "zero-discharge" facility was discarded, and GRL was required to install a treatment plant to treat and release the accumulating cyanide-contaminated heap solution. Discharge was essential because there was too much fluid in the heap leach pad and it was affecting recoveries, operations, and ultimate shutdown. But treatment was necessary because every industrial discharge had to meet water quality standards that were established for the discharge.

Throughout a prolonged sequence of events, the operator's attempts to perfect its water treatment plant met no success. During 1989 and 1990 GRL attempted land application to polish and dispose of partially treated effluent. However, the land application project resulted in overland flow due to over application and GRL was cited again for water quality violations. Had the land application water not flowed overland, there might not have been an "unregulated discharge" and application to groundwater might have continued. The volume of fluid inside the heap leach pad grew steadily, inundating the ore, compromising resource recovery, and increasing the eventual risk.

### **The Waste Rock**

Much of the attention was focused on the heap leach pad, its water balance, land application, and related issues.

However, as mining progressed, a significant additional environmental issue developed over acid drainage and metals contamination from the site's waste rock piles. There was a lack of adequate characterization of the overburden and waste rock during the permitting process. The original limited impact permit application stated that because the rocks of the ore body came from the "oxide" zone, they had no acid generating potential. This observation was grossly incorrect.

Like thousands of other deposits in the world, the gold at Summitville formed when hydrothermal solutions deposited sulfide-rich base metal veins. Originally, the gold was extremely finely disseminated within the sulfides and, if not for the process of weathering, probably would not have been technically feasible to mine. Yet, as the cover rock above these ore-bearing deposits eroded, and water and oxygen percolated into the veins, dissolved sulfide minerals, precipitated iron oxide minerals in their place, and in the process left behind higher concentrations of native gold. Native gold in an oxide deposit is eminently more recoverable than gold in sulfide minerals. In a deposit like this, gold grades are highest and most easily recoverable in the upper, near-surface parts of sulfide veins and diminish downward.

It is generally known that the contact between the upper oxide zone and the sulfide zone below is not a horizontal plane, but rather is an undulating, roughly planar surface which is more or less parallel to the ground surface. It is common to find pockets or pods of sulfide minerals above the water table, even though they reside in the "oxide" zone. Variations in rock permeability allows water and oxygen to reach parts of the veins and restricts them from others.

Because sulfide minerals are not good candidates for cyanide heap leach processing, high sulfide-bearing rock, normally, is disposed without processing. Even at Summitville, grade control was exercised in order to limit the amount of sulfide minerals that reported to the heap. The pit geologist, using visual clues and analytical information from drill hole analyses, decided whether each load of rock was to be ore or waste. Owing to this segregation, the waste rock contains a higher abundance of base metal sulfide minerals than the heap. Unfortunately, these now are being released to the ground and surface waters, due to weathering. GRL discarded extensive amounts of waste rock in several waste rock piles throughout the permit area. They carelessly placed at least one of these piles in a spring fed (groundwater fed) bog which magnified the volume of acid drainage and metallic contaminants released. Had GRL comprehensively evaluated the feasibility of this venture, mining might never have been pursued.

Based on recent water quality monitoring data, it appears that in terms of metal loading, approximately 45% of the mine site's copper metal load (as high as 8,000 pounds per day) comes from the combined French drain sump beneath the heap leach pad, the Cropsy waste pile, the beaver mud dump, and the north waste rock pile.

### **The Reynolds Adit**

At some point in the development of practically every historical mining district in Colorado, there was constructed a dewatering tunnel that lowered the water table to avoid pumping costs and difficulties while mining the deeper levels. In Central City the dewatering tunnel is the ARGO Tunnel; in Cripple Creek, the Carlton Tunnel; in Leadville, the Yak Tunnel; and in Summitville, the Reynolds Adit. The Reynolds Adit, located near the base of South Mountain, was completed in 1897. Prior to plugging in 1994, the Adit flowed continuously, varying from a low of approximately 100 gallons per minute in the winter to an average high of approximately 400 gallons per minute during spring melt. Abnormally high undocumented snowmelt flows as high as 1,600 gallons per minute have been reported.

Because the Reynolds Adit drains the mineralized portion of South Mountain, historically it has evidenced relatively high metal discharges. Prior to 1988, copper concentrations typically reached 20 to 30 milligrams per liter (mg/L). Beginning in 1989, however, the metals content of the Reynolds Adit effluent began to increase (Golder Associates, Remedial Measures Plan, 1992). In 1992 copper in the effluent reached about 130 mg/L. Even though the mechanism is not completely understood, it appears that GRL's excavation of the open pit, which was not drained and which flooded about 300 feet above the Reynolds Adit, stimulated the infiltration of surface water and promoted oxidation of the ore body. Of course, this man-induced activity resulted in an increased release of acid and metals to the Reynolds Adit, following natural processes of weathering. By 1989, the GRL open pit had become an undrained sump.

In June of 1993 the Reynolds Adit effluent reached a maximum documented concentration of 650 milligrams of copper per liter. The past ten years monitoring demonstrate that the highest metal concentrations coincide with the highest flow rates.

Based on recent water quality monitoring data it appears that, in terms of metal loading, as much metal flowed from the Reynolds Adit as from the remainder of the entire mine site, including the waste rock piles. Prior to its plugging in January of 1994, approximately 50% of the metals yield from the entire mine site (as high as 9,000 pounds of copper per day) issued from the Reynolds Adit.

## **PURPOSES OF CHARACTERIZATION**

### **Rumor Control**

An immediate concern voiced by local government officials, business representatives, environmental advocates and local citizens alike, was the need for factual information and the control of misinformation. The EPA and the State desired to disseminate factual and precise information concerning potential health and environmental risks. Testing of municipal and private water supplies was expedited. Representative agricultural produce and animal tissue from areas exposed to potentially contaminated Alamosa River water were analyzed to verify safety of the food supply and to quell potentially damaging food scare rumors. The initial preliminary determinations required thorough and expeditious verification. Most of the results are reported in this volume.

### **Risk Assessment**

In accordance with CERCLA regulations and EPA procedure, complete human health and ecological risk assessments must be completed to define the nature and extent of the risks related to historic and potential contaminant releases from the Summitville mine site. Additional statutes such as the Migratory Bird Treaty and the Threatened and Endangered Species Act also require evaluation of ecological impacts. Both a human health risk assessment and an ecological risk assessment are in progress, and although preliminary indications show minimal risk to human health, aquatic life are severely at risk.

### **Feasibility Study**

CERCLA statutes and EPA superfund regulations also require thorough evaluation of the relative feasibility of proposed emergency response "removal" actions and longer term superfund "remedial" actions. Primary among these feasibility evaluations is the ability of the proposed action to curtail the contaminant release and provide a remedy for the impacts of that release.

### **Determination of Background Environmental Conditions**

CERCLA precludes cleaning up sites to conditions cleaner than those which preceded contaminant release. Provided background water quality and ecological conditions are documented, this can be a relatively straightforward determination. Yet in the case of the Summitville mine site, no comprehensive quantitative environmental monitoring data existed with which to characterize the environmental conditions prior to 1984.

The Summitville mine site is probably representative of the majority of historic mine sites in the western U.S. in its paucity of pre-disturbance background data. Many of the characterization projects conducted both on-site and off-site provide insight to deduce environmental conditions which existed prior to contaminant release.

Current methodologies preclude making model determinations about the quality of water prior to anthropogenic disturbances. Although the Clean Water Act provides that streams must consider natural or man-induced pollution caused prior to implementation of the act, such classifications do not consider potential impacts from mines that operated after the act was passed. Summitville, lacking acceptable environmental baseline information, was unable to distinguish pollution caused by their operations from that caused by previous ones, and by natural conditions.

### **Establishing the Remedial Targets**

The majority of the early emergency response and remedial activities implemented at the Summitville mine site have concentrated on the prevention of contaminant release. However, as the remedial projects proceed, the yet-to-be determined pre-disturbance conditions will be approached as subsequent actions are implemented. In order to make efficient and cost-effective decisions between optional technologies and scales of activity, it will become increasingly important to comprehensively characterize the on-site and off-site environmental conditions and impacts of contaminant release. The preliminary results of characterization studies have been instrumental in establishing interim remedial targets for the Summitville mine site. As more comprehensive characterization data are assembled the interim remedial targets will be amended.

Currently, the interim goal is to restore the Terrace Reservoir to fishery status, and meet promulgated in-stream standards in the Alamosa River. The Alamosa is classified as a Class II cold-water fishery, with segments below the Wightman Fork confluence having a seasonal classification for copper.

## **OTHER ISSUES**

### **Off Site Studies**

Much of the information about Summitville pertains not to the site but rather to the off site areas. Studies of the off site areas, most of which are detailed in this volume, pertain to water quality in the Alamosa River, irrigation water, potential effects on crops, on livestock forage, and on crops. Wetlands in the western nether tip of the Alamosa National Wildlife Refuge were examined for potential impacts as well as several palustrine wetlands in

the Alamosa River and La Jara Creek. The nature of these studies, though beyond the scope of this review, is impressive for its diversity and complexity. The studies covered disciplines in agronomy, agriculture, water quality, human health, aquatic life biology, aquatic chemistry, geology, geochemistry, limnology, bacteriology, process chemistry, civil engineering, hydrology, hydrological engineering, and terrestrial biology.

### **Other Contaminant Sources**

In the Alamosa River basin are three major areas that have undergone extensive hydrothermal alteration. This alteration formed above and alongside the margins of molten intrusive igneous rocks that formed within a few million years of the Summitville mineralization. Regionally, they are part of the late-stage igneous rock suites that intruded the San Juan volcanic sequence.

The San Juan volcanic field hosts several major calderas where intrusive igneous rocks actually exploded through the overlying volcanic rocks. The extrusions spilled out onto the previously deposited rocks, leaving behind a nearly circular shaped depression that filled in part with other later forming rocks (see Bove and others, this volume, for a more detailed explanation). The Platoro caldera hosts two stocks, igneous intrusive bodies that intruded part way into the crust. These are the Alamosa River stock and the Jasper stock. These stocks are circumscribed in part by zones of hydrothermal alteration, and the altered zones contain anomalous concentrations of minerals, particularly iron sulfide. The hydrothermal alteration zone at Summitville, where the pluton lies at some depth below the surface, is less extensive but obviously well mineralized. Other stocks and hydrothermal alteration zones occur within and adjacent to the caldera (see Bove and others, this volume).

The hydrothermally altered areas are key to understanding the region, geologically, and some may have profound impacts on water quality. At a minimum, the altered areas contain pyrite (iron sulfide), which upon oxidation forms sulfuric acid. The acid, in turn, may dissolve other adjacent minerals, and the process can lead to environmental conditions that in the worst case will not support soil life and which pollutes local streams with acid and metals that were dissolved by the acid.

The rates of physical erosion is generally very high in these altered zones because of the lack of protective soil caps, acidity, and the self-disaggregating nature of some of the rocks. Extreme examples of physical erosion are evident especially in Alum Creek and Burnt Creek, but high erosion rates are also operative in Iron, Bitter, Wightman Fork and Burnt Creeks. The net effects of chemical and physical erosion in these areas has not been quantified.

## **Summitville and the Mining Law of 1872**

Numerous accounts of the Summitville situation cite flaws in the 1872 mining law as part of the reason for the present situation. However, the problems at Summitville, environmental problems, are not covered by the 1872 Mining Law, which is a property law that applies to some federal land. Revisions in the royalties to be paid for use of these federal lands, changes in the patent law, or other property provisions would not have affected the problems at Summitville.

## **ENVIRONMENTAL RESPONSE ACTIONS**

Immediately upon taking over the Site, plans were developed to control releases and reducing the potential for release of contaminants from the Site. Once open pit mining was initiated at Summitville, concentrations of toxic metals had been steadily increasing in the Alamosa River watershed. As a result of environmental clean-up actions, this trend had been reversed. By 1995, metal loadings released from the Site have been significantly reduced.

### **Contaminants of Concern**

Contaminants of Concern (COC) were identified based on elevated concentration and potential toxicity of mobilized chemicals. These concentrations were compared to site-specific background levels, which were determined by standard statistical analysis (MK, 1994). Potential adverse effects on human health and the welfare of wildlife were preliminarily assessed (EPA, 1992). COC identified for the Site are copper, iron, cadmium, lead, silver, zinc, arsenic, aluminum, mercury and cyanide. Copper was found to be a reliable indicator of the contaminant loadings from the Site. All of these contaminants, except cyanide, are found at the Site in naturally occurring minerals and compounds. They are made soluble during a natural chemical process that results in acidic metals laden water called Acid Mine Drainage (AMD). This process accelerated by the mining activities which took place at the Site.

### **Acid Mine Drainage**

Acid Mine Drainage (AMD) is the result of a natural occurring mineral oxidation process that can occur when these chemical ingredients are found together: oxygen, water, and sulfide minerals. Sulfide minerals oxidation by water derived from snowmelt and rainfall is a normal geologic process; however, it is markedly accelerated by increased exposure of sulfide minerals to water and oxygen which results of man-made excavations in sulfide-bearing, rock formations. Catalyzation of reactions by indigenous bacteria, *Thiobacillas ferrooxidans*, often accompanies and significantly accelerates the reactions. Primary metallic

sulfides and secondary sulfate minerals found at the Site are pyrite ( $\text{FeS}_2$ ) and marcasite ( $\text{FeS}_2$ ), pyrrhotite ( $\text{Fe}_{1-x}\text{S}$ ), covellite ( $\text{CuS}$ ), enargite ( $\text{Cu}_3\text{AsS}_4$ ), alunite (hydrous potassium aluminum sulfate -  $\text{KAl}_3(\text{SO}_4)_2(\text{OH})_6$ ), and jarosite (hydrous potassium iron sulfate-  $\text{KFe}_3(\text{SO}_4)_2(\text{OH})_6$ ).

Pyrite and other sulfide minerals undergo weathering and produce acid solutions containing sulfate ions along with iron, copper, and other dissolved metals. These acid solutions usually have a pH of less than 4.0 and are responsible for degradation of water quality (Siwik and others, 1989).

At Summitville, mining activities resulted in additional sulfidic material surface area available for contact with oxygen and water. Air and water contact additional surface area provided by broken rock accelerates oxidation of minerals and creation of low pH drainage. This drainage water is high in acidity, sulfate ( $\text{SO}_4$ ) ions and dissolved metals.

AMD contributes metal loading to Wightman Fork and Alamosa River. This creates adverse conditions preventing the growth and maintenance of a healthy aquatic ecosystem. These adverse effects have been noted in various studies of water quality of Wightman Fork and the Alamosa River (SCMCI, 1992).

Of the twelve areas identified on the Site as sources of AMD, the Cropsy Waste Pile, the Summitville Dam Impoundment, the Beaver Mud Dump, the Mine Pits, and the underground workings that are below the Mine Pits, are considered to be the most significant contributors to the generation of metal-laden acidic (low pH) water (Ecology & Environment, 1993; MK, 1994).

### **The Overall Clean-up Approach**

The overall approach emphasizes the stabilization and control of on-site sources such that aquatic, agricultural, and drinking water uses in the Alamosa river watershed are restored and/or maintained with minimal active water treatment requirements. Although this approach results in high initial construction costs, effective source control will reduce annual water treatment costs. Thus, the overall project cost is reduced. Control of the sources of contamination is being accomplished by reducing the generation of AMD draining from the adits and waste rock piles, detoxification and capping of the heap leach pad, and active water treatment during remedy construction.

A two part plan was developed to control AMD from the most significant sources. The first part was initiated immediately to control AMD being released from the Site. This part focused on improving the efficiency of the water treatment facilities and controlling the AMD discharges from the mine drainage adits. The discharges from the adits was accomplished by plugging the Reynolds and Chandler adits.

The second part of the plan focused on reducing the AMD generated from mine waste piles and areas disturbed by mining. A lined and capped repository located in the mine pits for AMD generating waste rock and revegetation was determined to be the preferred alternative to address these sources of contamination.

### **The Remediation Plan - Part 1**

The first part of the remediation plan was aimed at controlling AMD from being released from the Site. This part included improvements to the efficiency and capacity of the water treatment plants and plugging of the Chandler and Reynolds mine drainage adits. EPA found that the capacity of the water treatment plants at the site were greatly undersized. Initially, there were three treatment plants located at the Site with a combined treatment capacity of approximately 300 gpm. The discharge from the Reynolds adit alone was greater than 900 gpm during spring runoff. The cost of operating these facilities was as high as \$1.5 million per month.

The water treatment facilities were improved by consolidating the operations into one facility and improving the efficiency of the treatment process. Once improvements are completed, the treatment capacity will be increased to 1,400 gpm. A 90 million gallon reservoir has been added to the water treatment system to store contaminated water during spring runoff when flows exceed the capacity of the water treatment plant. The storage reservoir will also be used to store contamination water during the winter months, enabling the site operations to be shut down during the winter months. Improvements to the water treatment facility have resulted in a reduction of cost from \$18 million per year to \$3.0 million per year while increasing the treatment capacity by more than 4.5 times.

Active water treatment is being used as an interim measure to control the release of AMD generated on the site until the stabilization of the sources of AMD is completed. Once the sources are stabilized, it is anticipated that the need for active water treatment will be significantly reduced.

In addition to controlling the release of AMD from the Site, water treatment was also used to remove the residual cyanide from the Heap Leach Pad. Water was pumped from the bottom of the Heap Leach Pad to the water treatment facilities where cyanide and metals were removed. The purified water was then applied to the top of the Heap Leach Pad. The rinsing process effectively reduced levels of cyanide in the Heap Leach Pad such that it no longer presents a threat to the environment.

The Reynolds Adit was the major mine drainage facility constructed to provide a dewatering function for the Summitville Mine. This drainage was found to be the largest single source of AMD. The AMD was a result to

water percolating through the sulfide-bearing rock in surrounding the underground workings.

It was determined that plugging the Reynolds adit would be an effective method to control this discharge. The plugging of the adits will significantly reduce the generation of AMD by limiting the oxygen available for oxidation of sulfides. Once the saturated condition is established, the groundwater is the only medium capable of carrying oxygen into the system. The low flux of oxygen through the groundwater will limit the oxidation of the sulfide minerals, reducing acid generation within the saturated ore zone. The reduction of acid generation will limit the leaching of the metals found in the rock.

Groundwater modeling indicated that, once the Reynolds adit was plugged, groundwater would rise to the elevation of the Chandler and then discharge through the Chandler Adit. The Chandler adit was driven to connect and access the underground workings at the North end of the ore deposit. To further saturate the ore body, the Chandler Adit was also plugged.

The reduction in loading from the Reynolds adit due to plugging was substantial. Prior to plugging the average discharge was 80 gpm with copper concentrations of 140 ppm of copper. After plugging, the discharge from the Reynolds adit was reduced to an average of 7 gpm with concentrations of copper of 50 ppm. This represents a reduction in copper loading of 97 percent.

### **The Remediation Plan - Part 2**

Mining wastes contained in the Cropsy Waste Pile, Beaver Mud Dump, and Summitville Dam Impoundment were found to be significant contributors to the metals loading in the Wrightman Fork. Upon investigation, it was found that the source of the water was not from precipitation, but from groundwater entering the waste piles from below. In the Summitville Dam Impoundment, a historic tailings pond, AMD was generated by the contact of surface water collected with the waste stored in the impoundment. It was estimated that 36,000 pounds of copper per year was transported from these source areas into the Wrightman Fork.

To address these sources of AMD, an engineering evaluation was completed. The results of this evaluation indicated that excavation and placement of the mine waste in a lined and capped repository located in the mine pits was the most effective measure to control these sources of AMD. There were two major benefits to this response action. First, the waste was removed from the sources of water which was causing large volumes of AMD to be generated. The wastes were placed in a location which AMD generation could be controlled. The second benefit was the mine pits would be filled, capped, and graded such that the area would be free draining. The mine pits would

no longer act as a catchment basin for precipitation. Thus, reducing the volume of water entering the ground and the underground workings resulting in a reduction in contaminate loadings.

Beginning in September 1993, waste rock from the Cropsy Waste pile, Beaver Mud dumps, and Summitville Dam Impoundment were beginning to be excavated and placed in the Mine Pits. In November 1995, all of the waste from these sources had been excavated and placed in the the Mine Pits.

The final stage of this part of the remediation plan is the reclamation of the 550 acres of disturbed area and the closure of the Heap Leach Pad. Reclamation will stabilize all exposed areas to reduce erosion. The revegetation will reduce the amount of moisture and oxygen available in the subsurface available for AMD generation.

Although the Heap Leach Pad is not a currently source of AMD, there is the potential that it could become a source of AMD in the future. To maintain the favorable conditions within the HLP, the HLP will be recontoured and capped to reduce the amount of water percolating through it.

## CONCLUSION

By EPA using its emergency and long-term Superfund response authorities, a catastrophic release of contaminated water to the Alamosa river watershed was prevented and stabilization of AMD generating waste rock were quickly addressed. Remediation of the Summitville Mine is not yet complete. However, the amount of toxic metals released from the Site has already decreased. With completion of the environmental response actions, it is anticipated that the need for longterm active water treatment will be significantly reduced and possibly eliminated.

## REFERENCES

Danielson, I. and A. McNamara, 1993, The Summitville Mine; What Went Wrong.

Ecology and Environment, 1993, Engineering Evaluation/Cost Analysis: Cropsy Waste Pile, Beaver Mud Dump, Cleveland Cliffs Tailings Pond, Mine Pits, Summitville Minesite.

Environmental Protection Agency (EPA), 1992, Removal Site Investigation/Action Memorandum.

Environmental Protection Agency (EPA), 1994, Focused Feasibility Study for the Cropsy Waste Pile, Cleveland Cliffs Tailings Pond, Beaver Mud Dump, and Mine Pits at the Summitville Mine Superfund Site.

Environmental Chemical Corporation (ECC), 1994, Reynolds Adit Control Program - Project Report for the Summitville Mine Superfund Site; prepared for USEPA, Region VIII and Bureau of Reclamation.

Environmental Chemical Corporation (ECC), 1994, Focused Feasibility Study for Reclamation at the Summitville Mine Superfund Site; prepared for USEPA, Region VIII and Bureau of Reclamation.

Environmental Chemical Corporation (ECC), 1994, Focused Feasibility Study for Water Treatment at the Summitville Mine Superfund Site; prepared for USEPA, Region VIII and Bureau of Reclamation.

Knight Piesold and Company, 1993, Chronologic Site History: Summitville Mine, Rio Grande County, Colorado.

Morrison Knudson Corporation (MK), 1994 Focused Feasibility Study for the Heap leach Pad at the Summitville Mine Superfund Site; prepared for USEPA, Region VIII.

Morrison Knudson Corporation (MK), 1994, Summitville Mine Conceptual Site-wide Remediation Plan.

Plumlee, Geoffrey S. and others, 1995, Importance of Geology in Understanding and Remediating Environmental Problems at Summitville, Proceedings: Summitville Forum '95, Colorado Geologic Survey Special Publication 38.

Rye, R.O., R. Stoffregen, and P.M. Bethka, Stable Isotope Systematics and Magnetic and Hydrothermal Processes in the Summitville, Colorado Gold Deposit, 1990, USGS Open File Report 90-269.

Steven, T.A., Ratte, J.C., 1960, Geology and Ore Deposits of the Summitville District San Juan Mountains, Colorado. USGS Prof. Paper No. 343.

Stoffregen, R., 1987, Genesis of Acid-Sulfate Alteration and Au-Cu-Ag Mineralization at Summitville, Colorado, Economic Geology, v.82,p. 1575-1591.

Summitville Consolidated Mining Company, Incorporated, (SCMCI), 1992, Remedial Measures Plan - Final Report; Volume 1.



# GEOMORPHIC EVOLUTION AND HISTORY OF POLLUTION IN THE VICINITY OF THE SUMMITVILLE DISTRICT, SAN JUAN MOUNTAINS, COLORADO

Thomas A. Steven  
U.S. Geological Survey  
Box 25046, MS 913  
Denver Federal Center  
Denver, CO 80225



The history of natural pollution in the Summitville vicinity in the eastern San Juan volcanic field, Colorado, is closely tied to the igneous and hydrothermal activity, and to the subsequent geomorphic evolution of the area. This area has had a complex geologic history that progressed from intense volcanic, intrusive igneous, and related hydrothermal activity in late Oligocene and earliest Miocene time, to long-continued erosion and episodic tectonism throughout the remainder of Cenozoic time. Rocks associated with some of the Oligocene-early Miocene igneous centers were highly altered and locally mineralized during igneous activity, and these areas were variously exposed and subjected to weathering and erosion as the topography subsequently evolved. Inasmuch as hydrothermally altered rocks are potential sources for substances deleterious to human activities (pollutants), the history of "pollution" from this general area has varied in response to changing geologic and climatologic environments. The present surge of mine-related pollution from the Summitville district reflects only the latest episode in a long-term sequence of events, and is built on a base of natural pollution that has waxed and waned for nearly 30 million years. Unfortunately the present man-caused surge exacerbates a naturally-occurring surge that has resulted from accelerated deep erosion and enhanced weathering during the last 5-4 million years.

The Summitville district and its surroundings are within or adjacent to the Platoro caldera complex in the eastern San Juan volcanic field (figs. 1 and 2) (Lipman, 1974; 1975). This complex developed within a cluster of early to middle Oligocene andesitic volcanoes, and in response to a sequence of violent pyroclastic eruptions that emplaced the several ash-flow tuff members of the Treasure Mountain Tuff (30-29 Ma). The final caldera collapse formed the small Summitville caldera (north of modern Alamosa River, fig. 2) in the northern part of the complex, and this feature was in turn filled with a sequence of dense andesitic lava flows. Granodioritic magmas invaded the caldera complex toward the end of its development, and formed shallow intrusions along different caldera structures. Several of these intrusions localized convecting hydrothermal cells which altered, and in places mineralized, large bodies of volcanic and intrusive rock. Locally preserved siliceous sinter and other manifestations of thermal activity (Bove et al., 1995) indicate that some hydrothermal activity vented to the surface to form solfataras that were strongly acidic and probably metal-bearing.

Several million years later, at 23-21 Ma (Mehnert et al., 1973), volcanic activity was renewed along the western margin of the Summitville caldera where viscous silicic dacite to rhyolite lava was extruded to form volcanic domes and thick lava flows. The main extrusion formed the South Mountain dome ((5) on fig. 2) in the northern part of the complex, and emplacement of this dome was followed by intense hydrothermal activity in its core to form the altered and mineralized rocks that have been mined in the Summitville district (Gray and Coolbaugh, 1994). Hydrothermal activity took place within the then-new volcanic edifice, and inescapably vented to the surface as a solfataras. The intense acid-sulfate character of alteration, and the deposition of arsenic, copper, and other metals within a few hundred meters of the surface (Gray and Coolbaugh, 1994) strongly suggest that this solfataras also was the source of toxic effluents. Gray and Coolbaugh (1994) cite specific evidence for local deposition in a hot spring environment.

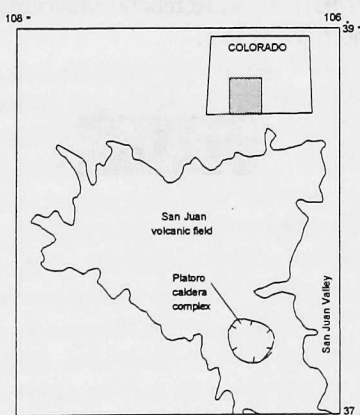

Figure 1. Index map showing San Juan volcanic field.

The main areas of altered rock of interest to the present report, as shown on fig. 2, are: (1) Jasper area; (2) Klondike Mountain (KM)-Lookout Mountain (LM) (Iron, Alum, and Bitter Creeks basins of Bove et al., 1994); (3) Crater Creek; (4) Platoro district (just south of Platoro); and (5) Summitville district.

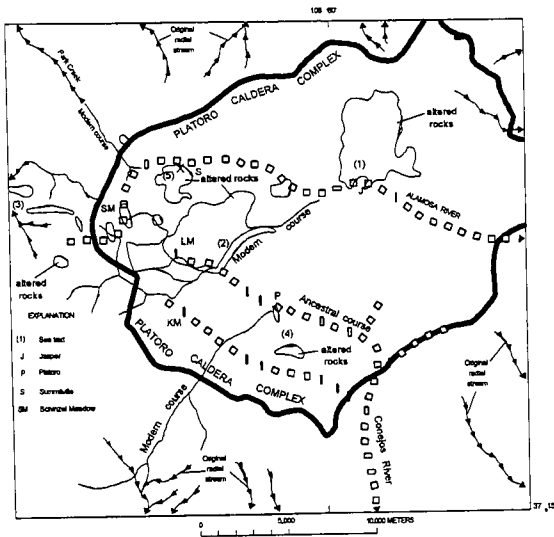

Figure 2. Relationship of drainage changes to geologic features in vicinity of Summitville Mining District, Colorado.

The Platoro caldera complex in early Miocene time probably was characterized by immaturely developed topography only slightly modified from the original constructional volcanic surface. The west-central part of the subsided area was covered by thick lava flows and volcanic domes related to the early Miocene (23-21 Ma) Summitville centers, which covered at least some of the Oligocene altered and mineralized areas (especially area (2)). The early Miocene mineralized area on South Mountain dome (5) was at least in part covered by slightly younger and related lava flows (Steven and Ratte', 1960). What minor external drainage that existed probably breached the wall of the caldera complex near the courses of the ancestral Alamosa and Conejos Rivers (fig. 2).

Most of the Miocene was marked by erosion which established two main outflowing drainage systems from the caldera area, an east-flowing ancestral Alamosa River, which drained the northern and central parts of the complex, and a south-flowing ancestral Conejos River, which drained the southern part of the complex. The divide between these systems was formed mainly by hills residual from the Summitville volcanic domes and lava flows. Both ancestral rivers flowed through broad open valleys flanked by rounded hills that stood from a few tens of meters to as much as a kilometer above the valley floors. Remnants of the valley of ancestral Alamosa River are exceptionally well preserved in the present landscape as the broad meadow just north and west of Summitville, and Schinzel Meadow (Flat) near the western margin of the caldera complex. The ancestral Conejos River valley is best manifested by broad wind gaps across the top of Klondike Mountain (KM on fig. 2) in the south-central part of

the caldera complex. Steven et al. (1995) date this high-level late Miocene surface as having reached its approximately present configuration by about 5-4 Ma.

Miocene erosion greatly modified the volcanic domes and lava flows related to the Summitville centers, but did not cut deeply into the underlying rocks of the caldera complex. Thus the early Miocene altered and mineralized rock on South Mountain (5) was exposed over nearly the full topographic range that exists today, but the older altered areas ((1), (2), (3), and (4)) were not deeply incised below levels where original surface-related features have been recognized. In particular, the Klondike Mountain (KM)-Lookout Mountain (LM) area was covered by younger lava flows for much of the Miocene, and as it was progressively exhumed, only the upper parts of the underlying rocks were exposed to weathering and leaching. These considerations (time available vs shallow depth of erosion) suggest that pollution during Miocene erosion was at a relatively low ebb, and perhaps came mostly from the more deeply exposed Summitville area (5). Whatever contributions came from the Jasper area cannot be assessed, but here also they would have been limited to those available in the upper and originally near-surface parts of the body of altered rocks.

Beginning after 5 Ma (latest Miocene), the San Juan volcanic field was uplifted sharply and tilted eastward toward the San Luis Valley (Steven et al., 1995). The late Miocene surface described above now can be recognized from altitudes of near 2,500 m at the east edge of the mountains, to 3,500 m in the paleovalley near Summitville. The uplift rejuvenated erosion along all streams in the mountain area, and caused sharp downcutting of canyons. Depth of erosion is everywhere approximately proportional to uplift shown by relative levels of the late Miocene surface. Within the caldera complex, these canyons are now steep-walled, as much as a kilometer deep, and except where widened by glaciers, show little evidence for lateral erosion. Downcutting still dominates erosion.

Accelerated downward and headward erosion was strongly influenced by differential rock resistance to erosion, and this has resulted in some dramatic changes in stream courses. Most important in influencing changes in natural pollution, a minor western tributary to ancestral Alamosa River tapped headward into soft highly altered rock in the Klondike Mountain-Lookout Mountain area (2) which was vastly more susceptible to erosion than the resistant andesite lava flows underlying the broad valley east of Summitville. This tributary extended rapidly headward and downward, and captured in turn the headwater tributaries of ancestral Conejos River, and then the uppermost parts of ancestral Alamosa River in Schinzel Meadow (Flat). The captured water enhanced erosion even more, and the sharp canyon between Klondike Mountain (KM) and Lookout Mountain (LM) was cut to a depth of more than a kilometer, exposing walls of soft highly altered and pyritized rock (Bove et al., 1995; this volume).

At the same time, the diminished ancestral Conejos River was unable to maintain its course across Klondike Mountain (KM), and a tributary from the west that entered near the present town of Platoro became the dominant source of water, creating the present anomalous U-shaped (plan view) headwaters configuration of modern Conejos River. Park Creek on the northwest side of the caldera complex did not breach into the caldera area until after uplift and rejuvenation; at that time it extended into the area of the late Miocene valley west of Summitville to capture a short segment of the greatly underfit stream that then flowed there.

Downstream from the area of complex stream captures, the Jasper area (1) was deeply entrenched during rejuvenation, and the north wall of the resulting canyon exposes highly altered rock to a height of nearly 1.5 km.

The net effect of enhanced erosion during the last 5 million years has been to divert a significant amount of water from ancestral Conejos River to a realigned Alamosa River, a miniscule loss of water to Park Creek, and deep erosion and exposure of several highly altered and mineralized areas that formerly were relatively minor sources of natural pollution. Alamosa River thus gained not only water, but progressively increasing contributions of polluting acid and metals. Bove et al. (1995; 1996; this volume), Walton-Day et al., (1995), and Barry (1996) have documented the sources, components, and concentrations of this natural pollution from the Klondike Mountain-Lookout Mountain area (2) under modern conditions. Comparisons with similar factors in adjacent areas are difficult because of the many independently acting geological, chemical, environmental (largely weather) variables (see cited references for details); however, as a not necessarily typical example, Bove et al. (1996, pl. 9) show that at least in the summer of 1994 the loading factor (mg/sec) of sulfate in the Alamosa River just above the inflow of water from Summitville was about a quarter of that below that inflow.

The upper Alamosa River area thus has been a source of pollutants for nearly 30 million years. Rates, quantities, and concentrations have varied according to vagaries of weather and geomorphic evolution, but even total mitigation of present-day mine-related pollution (Gray et al., 1994) would only partly modify what has been and will continue to be a naturally inhospitable environment.

## REFERENCES

- Barry, T. H., 1996, The geochemistry of natural waters draining hydrothermally altered and mineralized terrains in the upper Alamosa River basin, Colorado: Auburn, Alabama, Auburn University unpub. M.S. dissertation, 219 p.
- Bove, D. J., Barry, Thomas, Kurtz, Jeffrey, Hon, Ken, Wilson, A.B., Van Loenen, R.E., and Kirkham, R. M., 1996, Hydrothermal alteration assemblages as a control on water chemistry, upper Alamosa River, Colorado: (this volume).
- Bove, D. J., Barry, Thomas, Kurtz, Jeffrey, Hon, Ken, Wilson, A. B., Van Loenen, R. E., and Kirkham, R. M., 1995, Geology of hydrothermally altered areas within the upper Alamosa River basin, Colorado, and probable effects on water quality, in Posey, H. H., Pendleton, J. A., and Van Zyl, D., eds., Proceedings--Summitville Forum, '95, January 17-20, 1995: Colorado Geological Survey Special Publication 38, p. 35-41.
- Bove, D. J., Wilson, A. B., Barry, T. H., Hon, Ken, Kurtz, Jeffrey, and Van Loenen, R. E., 1996, Geology, alteration, and rock and water chemistry of the Iron, Alum, and Bitter Creeks areas, upper Alamosa River, southwestern Colorado: U. S. Geological Survey Open File Report 96-039, scale 1:12,000.
- Gray, J. E., and Coolbaugh, M. F., 1994, Geology and geochemistry of Summitville, Colorado: an epithermal acid sulfate deposit in a volcanic dome: Economic Geology, vol. 89, p. 1906-1923.
- Gray, J. E., Coolbaugh, M. F., Plumlee, G. S., and Atkinson, W. W., Environmental geology of the Summitville mine, Colorado; Economic Geology, vol 89, p. 2006-2014.
- Lipman, P. W., 1974, Geologic map of the Platoro caldera area, southeastern San Juan Mountains, southwestern Colorado: U. S. Geological Survey Miscellaneous Investigations Series Map I-828, scale 1:48,000.
- \_\_\_\_\_, 1975, Evolution of the Platoro caldera complex and related volcanic rocks, southeastern San Juan Mountains, Colorado: U. S. Geological Survey Professional Paper 852, 128 p.
- Mehnert, H. H., Lipman, P. W., and Steven, T. A., 1973, Age of mineralization at Summitville, Colorado, as indicated by K-Ar dating of alunite: Economic Geology, vol. 68, p. 399-401.
- Steven, T. A., Hon, Ken, and Lanphere, M. A., 1995, Neogene geomorphic evolution of the central San Juan Mountains near Creede, Colorado: U. S. Geological Survey Miscellaneous Investigations Series Map I-2504, scale 1:100,000.
- Steven, T. A., and Ratte, J. C., 1960, Geology and ore deposits of the Summitville district, San Juan Mountains, Colorado: U. S. Geological Survey Professional Paper 343, 70 p.
- Walton-Day, Katherine, Ortiz, R. F., and von Guerard, P. B., 1995, Sources of water having low pH and elevated metal concentrations in the upper Alamosa River from the headwaters to the outlet of Terrace Reservoir, south-central Colorado, April-September, 1993, in Posey, H. H., Pendleton, J. A., and Van Zyl, D., eds., Proceedings--Summitville Forum, '95, January 17-20, 1995: Colorado Geological Survey Special Publication 38, p.

Pendleton, J. A., and Van Zyl, Dirk, eds., Proceedings:  
Summitville Forum, '95: Colorado Geological Survey  
Special Publication 38, p. 160-170.



# HYDROTHERMAL ALTERATION ASSEMBLAGES AS A CONTROL ON WATER CHEMISTRY, UPPER ALAMOSA RIVER, COLORADO

By

Dana J. Bove<sup>1</sup>, Anna B. Wilson<sup>1</sup>, and Thomas H. Barry<sup>2</sup>

<sup>1</sup>U.S. Geological Survey, Box 25046, MS 905, Denver, Colorado 80225

<sup>2</sup>Geology Department, 210 Petrie Hall, Auburn University, Auburn, Alabama 36849



Water draining the Iron, Alum, and Bitter Creek (IABC) basins in the headwaters of the Alamosa River, upstream from influence of the Summitville mine, is extremely degraded (pH <3; conductivity >1,900  $\mu$ s/cm) and has been since the onset of stream downcutting nearly 5 million years ago (Steven, this volume). The presence of ancient iron-oxide cemented conglomerates many meters above modern drainages is strong evidence that metal-rich, acid drainage has been occurring in these basins for thousands, if not millions, of years. These highly altered and pyritized basins are underlain by igneous and volcanic rocks that underwent extensive hypogene hydrothermal alteration 29-26 million years ago (Lipman and others, in press). Geologic and aqueous geochemical studies from IABC drainages above the Wightman Fork/Alamosa River confluence document natural contamination and show the interrelationship between specific hydrothermal alteration assemblages and local stream and spring chemistry.

The IABC basins encompass roughly 11 km<sup>2</sup> of intensely altered and weakly mineralized rock on the northern margin of the Alamosa River stock, a large intrusive body. A later phase of this stock, the Alum Creek porphyry, is the focus of the most intense alteration in this area. A classic porphyry-style, quartz-sericite<sup>1</sup>-pyrite (QSP) alteration assemblage is centered around the Alum Creek porphyry (fig. 1) and is characterized by stockwork quartz-pyrite veinlets containing sparse molybdenite. Pyrite, which occurs ubiquitously throughout altered rocks in the IABC basins, is most prevalent in zones of quartz-sericite-pyrite alteration, where it averages about 3 to 5 volume percent of the rock.

The intensity of QSP alteration decreases outward and upward from the center in Alum Creek (fig. 1) as denoted mostly by a gradual decrease in both density of quartz-pyrite stockwork veinlets and silica flooding. Unpublished drill core data (Anaconda reference collection housed at the University of Wyoming, Laramie, Wyoming) indicate that QSP-altered rock extends several feet below the base of lower Alum Creek, with more than 70 percent of the rock containing greater than 1-2 volume percent pyrite. Several small centers of QA-altered rock crop-out on the south and western slopes of Lookout Mountain (fig. 1), nearly 600 m

above the QSP zone in Alum Creek. These QA centers grade upward into opaline ledges and siliceous sinter deposits that are remnants of an ancient hot springs environment. The QSP zones also grade laterally into weakly argillized (WAS) and finally into propylitized (PROP) assemblages. Pervasive argillic alteration (ARG), characterized by the presence of kaolinite, commonly in the absence of pyrite, is superimposed upon original QSP-altered rocks in the IABC basins (fig. 1). The argillic alteration assemblage was formed by extremely acid supergene fluids generated by the oxidation of pyrite by surface or meteoric water.

Figure 2 and table 1 depict geochemical data compiled from water sample sites affected by near end-member hydrothermal alteration assemblages. From these data it is apparent that the individual alteration assemblages produce distinctive aqueous geochemical signatures, especially when comparing the geometric mean or median of sample values. A plot of the sum of selected base metal concentration versus pH (fig. 2) illustrates that the most chemically-degraded water is produced by QSP-altered rocks, followed by argillic (ARG), weak argillic/sericitic (WAS), quartz-alunite (QA), propylitic (PROP), and unaltered (F) rocks. As summarized in table 1, water draining from QSP- and ARG-altered assemblages have the most degraded water with median pH values of 2.8 and 3.2, respectively. Geometric mean conductivity values for the same assemblages are 1915 and 595  $\mu$ s/cm, and sum of base metals (Zn+Cu+Cd+Ni+Co+Pb) is 1121 and 231 ppb, respectively. The QA, WAS, PROP, and unaltered assemblages, which contain progressively less pyrite due to either supergene or primary processes, have median pH values of 5.4, 4.5, 6.8, and 6.6, respectively. Specific conductivity (geometric mean) for these respective assemblages is 20, 207, 88, and 24  $\mu$ s/cm, whereas, the geometric mean sum of base metals is 11, 70, 15, and 6 ppb. Thus the type of alteration is directly related to the pH and metal content of the water.

Pyrite is of great environmental significance due to its role in the generation of acid waters and the liberation of heavy metals into the surrounding watersheds (Singer and Stumm, 1970; Forstner and Wittman, 1979). Pyrite

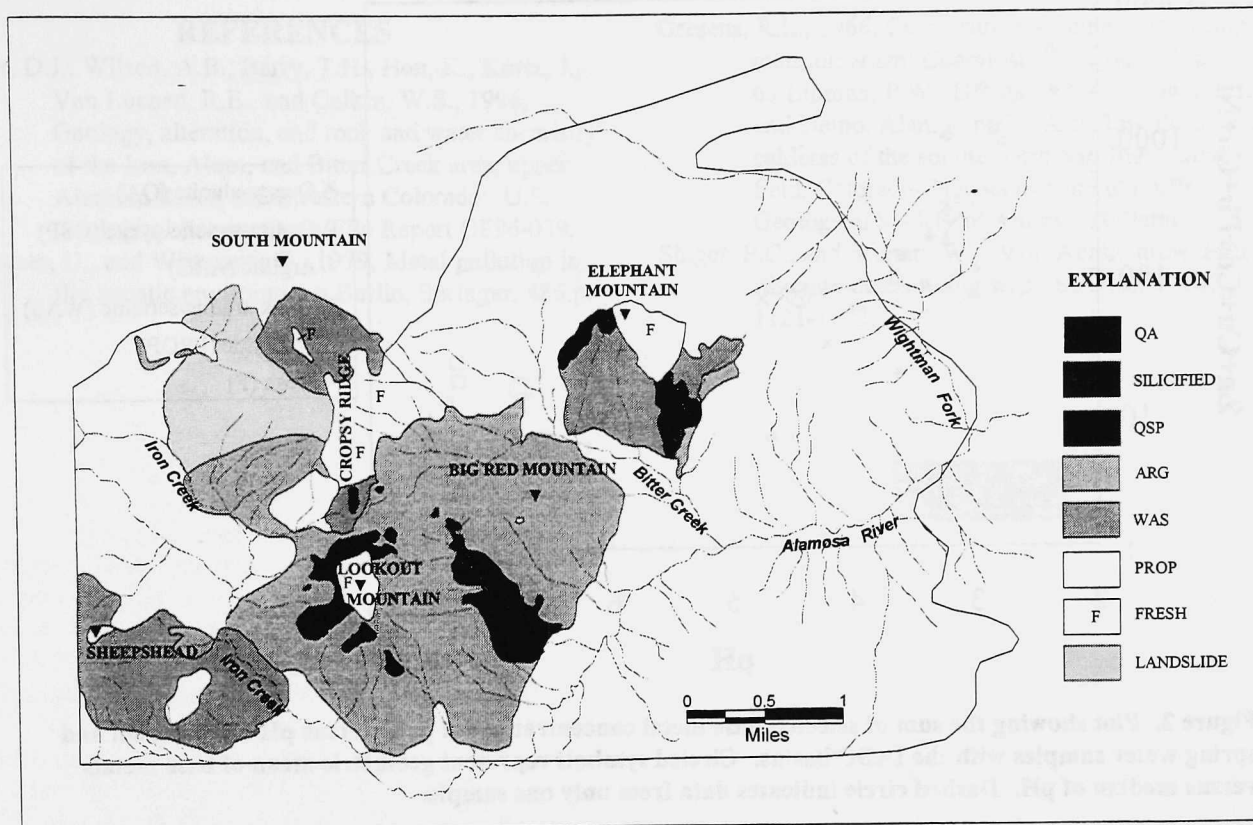

**Figure 1. Map showing distribution of hydrothermal alteration assemblages in the IABC study area. Alteration assemblages confirmed by X-ray diffraction analysis and characterized as follows: (QA) quartz and alunite replacement of volcanic rocks; (Silicified) fine-grained quartz and chalcedony replacement of volcanic rocks; (QSP) quartz-sericite-pyrite assemblage; includes quartz stockwork veinlets; (ARG) argillic assemblage, contains kaolinite and completely altered feldspars; (WAS) weak argillic/sericitic assemblage, contains kaolinite and (or) sericite; feldspars metastable; (PROP) propylitized rocks, weakly altered with chlorite, epidote, and calcite mainly after mafic minerals; (F) unaltered rocks; (Landslide) Quaternary landslide blocks, blocks are mostly propylitized and unaltered. Note: argillic (ARG) assemblage combines argillic (ARG) and (QSP-K) assemblages of Bove and others (1996). Map modified from Bove and others (1996).**

oxidation in and adjacent to QSP-altered rock generates extremely acid meteoric water that continues to react with sericite and pyrite within the QSP mineral assemblage. This chemical attack on QSP-altered rocks has resulted in the superimposition of a supergene argillic alteration assemblage (ARG) characterized by the presence of kaolinite, commonly in the absence of pyrite.

Mass balance calculations were performed on two sample pairs to ascertain chemical changes (net liberation to ground water) that took place during transformation from QSP- and WAS-altered rocks to a supergene ARG alteration assemblage. Samples within each pair were collected within a few feet of the other and in the same rock type to ensure limited chemical variability in the parent rock or protolith. In order to compare actual gains and

losses of elements during supergene transformation, the bulk rock density for each sample was determined by dividing the weight of the dry sample by its volume. As a result, the chemical compositions of the ARG-altered samples could be recalculated and compared to the equivalent QSP/WAS-altered parent on the basis of weight per unit volume of rock (Gresens, 1966). Preliminary mass balance calculations on both pairs indicate net losses of >75 percent Fe, K, Mn, Cu, Ni, Co, and pyrite, and between 20-40 percent Si, Al, and Mg during this supergene transformation. Water as a component of the mineral structure is the only major net gain, and Ti is relatively immobile.

<sup>1</sup> fine-grained muscovite

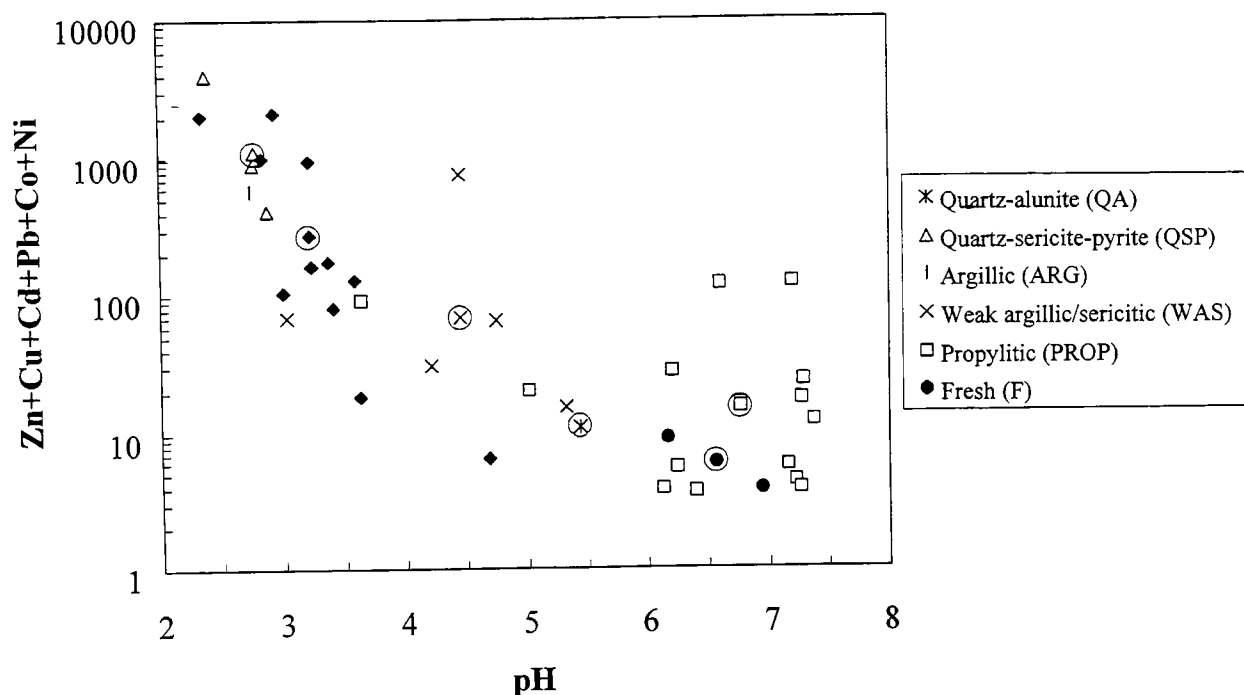

Figure 2. Plot showing the sum of selected base metal concentration (in ppb) versus pH from stream and spring water samples with the IABC basins. Circled symbols represent geometric mean of base metals versus median of pH. Dashed circle indicates data from only one sample.

Table 1. Geometric mean of waters draining specific alteration assemblages. N represents number of samples. See figure 1 for description of alteration assemblages. pH reported as median value.

Alteration assemblage	ARG	F	PROP	QA	QSP	W-AS
N	18	2	15	1	4	5
pH	3.22	6.56	6.77	5.44	2.78	4.46
Sp. Cond. ( $\mu$ S/cm)	595	24	88	20	1915	207
Fe-Tot (ppm)	19	0	0	1	187	2
Al <sup>3+</sup> (ppm)	10	0	0	0	65	1
Mg <sup>2+</sup> (ppm)	3	0	1	0	28	2
K <sup>1+</sup> (ppm)	1	2	1	1	1	2
Mn (ppm)	0	0	0	0	6	0
Ca <sup>2+</sup> (ppm)	8	3	9	3	54	10
Na <sup>1+</sup> (ppm)	2	2	3	2	3	5
Si <sup>4+</sup> (ppm)	21	13	5	14	30	15
SO <sub>4</sub> <sup>(2-)</sup> (ppm)	278	2	14	9	1404	77
Cl (ppm)	1	0	0	0	1	0
F- (ppm)	0	0	0	0	2	0
PO <sub>4</sub> <sup>(3-)</sup> (ppm)	1	1	1	1	1	1
Pb (ppb)	0	0	0	0	1	0
Zn (ppb)	95	3	6	4	662	47
Cu (ppb)	45	1	2	5	215	1
Cd (ppb)	2	1	1	0	7	0
Ni (ppb)	17	1	1	1	73	6
Co (ppb)	35	0	1	1	144	6
Mo (ppb)	0	0	0	0	1	0
Cr (ppb)	3	1	1	1	7	1
Zn+Cu+Cd+Pb +Co+Ni	231	6	15	11	1121	70

## REFERENCES

- Bove, D.J., Wilson, A.B., Barry, T.H., Hon, K., Kurtz, J., Van Loenen, R.E., and Calkin, W.S., 1996, Geology, alteration, and rock and water chemistry of the Iron, Alum, and Bitter Creek area, upper Alamosa River, southwestern Colorado: U.S. Geological Survey Open-File Report OF96-039.
- Forstner, U., and Wittmann, G., 1979, Metal pollution in the aquatic environment: Berlin, Springer, 486 p.
- Gresens, R.L., 1966, Composition volume relationships of metasomatism: *Chemical Geology*, v. 2, p. 47-65.
- Lipman, P.W., Dungan, M.A., Brown, L.L., and Deino, Alan, in press, Ash-flow sheets and calderas of the southeastern San Juan volcanic field, Colorado--New tales from old tuffs: *Geological Society of America Bulletin*.
- Singer, P.C., and Stumm, W., 1970, Acidic mine drainage--the rate-determining step: *Science*, v. 167, p. 1121-1123.



# NATURALLY OCCURRING, ACIDIC, METAL-RICH SPRINGS IN THE UPPER ALAMOSA RIVER BASIN, COLORADO

by

Robert M. Kirkham  
Colorado Geological Survey  
P.O. Box 172  
Monte Vista, Co 81144



and

Jonathan R. Lovekin  
Department of Geology and Geological Engineering  
Colorado School of Mines  
Golden, Colorado 80401

Compelling evidence of natural water-quality degradation was discovered in the Upper Alamosa River basin during an abandoned mine inventory of the Rio Grande National Forest conducted in 1993 and 1994. Dozens of naturally occurring, acidic, metal-rich springs (NOAMS) were observed during the inventory. They ranged from tiny individual seeps to prominent springs which have formed impressive and sometimes spectacular mounds of ferrisinter. NOAMS were found in hydrothermally altered areas near Iron, Alum, Bitter, and Burnt Creeks, and also along the mainstem of the Alamosa River. NOAMS typically have pH values in the 2 to 5 range, but a few were below pH 2. They frequently had high concentrations of dissolved iron, aluminum, and manganese and elevated levels of zinc, copper, arsenic, cobalt.

Terraces of ferriconglomerate up to about 10 meters above stream level, presence of "fossil" or dry NOAMS, and extensive exposures of deeply eroded,

strongly hydrothermally altered rock suggest the natural degradation has been an ongoing process at least for thousands of years and perhaps much longer. Comparisons between metal loadings from natural and mining sources in the segment of the Alamosa River above its confluence with Wightman Fork indicate mining sources are responsible for only a very minor amount of the dissolved metals in the river above the confluence with Wightman Fork. A realistic assessment of the remediation goals at the Summitville Superfund site should consider the natural degradation.

Based on analyses of ferrisinter and water collected from several NOAMS, the concentrations of iron, aluminum, arsenic, and copper in the precipitate correlates with that in the NOAMS. This suggests the trace element geochemistry of old ferro-deposits may be somewhat useful in predicting the chemistry of the water from which it was precipitated.

## REFERENCES

Kirkham, R.M., Lovekin, J.R., and Sares, M.A., 1995, Sources of acidity and heavy metals in the Alamosa River Basin outside of the Summitville mining area, Colorado, *in* Posey, H.H., Pendleton, J.A., and Van Zyl, D., eds., Proceedings: Summitville Forum '95: Colorado Geological Survey Special Publication 38, p. 42-57.



# ATTENUATION OF METAL CONCENTRATIONS IN TERRACE RESERVOIR, CONEJOS COUNTY, COLORADO, MAY 1994 THROUGH MAY 1995



By  
Robert W. Stogner, Sr.  
U.S. Geological Survey, WRD  
201 W. 8th Street, Suite 200  
Pueblo, CO 81003

## INTRODUCTION

Terrace Reservoir is a small, bottom-draining irrigation reservoir located on the Alamosa River in the San Juan Mountain Range in Conejos County, Colorado (fig. 1). Limited historical water-quality information is available for Terrace Reservoir. However, based on limited sampling conducted by the U.S. Geological Survey (Britton and Wentz, 1980) in 1974, and on comparison to water-quality standards, water quality was good. Historically, Terrace

The drainage basin upstream from Terrace Reservoir contains extensive areas of mineralized rocks, which in some areas have been mined intermittently since the late 1800's. Mining has occurred intermittently at the

Reservoir and the Alamosa River have had populations of brook trout, Rio Grande cutthroat trout, and rainbow trout. In the 1980's, the Colorado Division of Wildlife maintained a rainbow trout fishery in Terrace Reservoir. However, fish populations declined through the late 1980's; by 1990, fish were absent in most of the Alamosa River, including Terrace Reservoir, up to a point near Alum Creek (Woodling, 1995).

Summitville mine site (fig. 1) from 1873 to 1894, from 1926 to 1942, and from 1986 to 1992 (U.S. Environmental Protection Agency, 1993). Terrace Reservoir is located about 15 miles downstream from the Summitville mine site

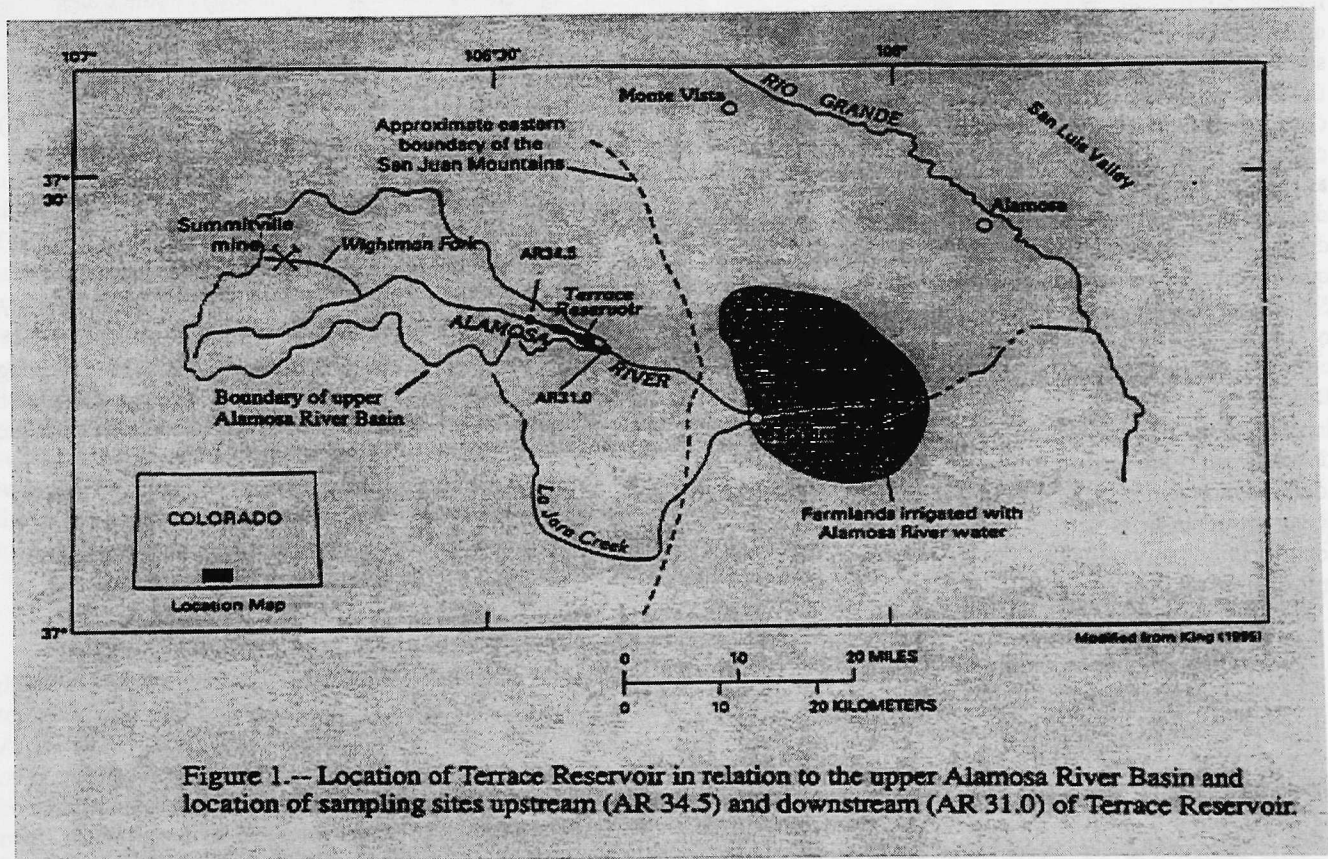

and receives drainage of low-pH, metal-enriched water. Drainage from the Summitville mine flows into Wightman Fork, a tributary of the Alamosa River. Wightman Fork has been identified as a primary source of aluminum, copper, iron, manganese, and zinc during peak flow and the falling limb of the spring runoff hydrograph (Walton-Day and others, 1995).

The Alamosa River is a primary source of water for crops and livestock in the southwestern part of the San Luis Valley. The extent that metal concentrations in the water column are attenuated in Terrace Reservoir is of interest to downstream users.

A study was conducted from May 1994 through May 1995 in cooperation with the U.S. Environmental Protection Agency to characterize the limnology and the spatial and seasonal distribution of metals in Terrace Reservoir.

### **Approach**

The limnological characteristics of Terrace Reservoir were evaluated using data collected at seven reservoir sites. The sites were selected to provide information on the spatial and seasonal variations of water temperature, specific conductance, dissolved oxygen, and pH. Onsite profile measurements were made biweekly from May 20, 1994, through August 17, 1994. Monthly profile measurements were made from September 1994 through November 1994, January 1995 through March 1995, and during May 1995. Profile measurements are measurements of temperature, specific conductance, dissolved oxygen, and pH made at 3-ft depth increments from the surface to the bottom of the reservoir. In addition to profiling, water-quality samples were collected at three of the seven sites to provide information on the spatial and seasonal variations in metal concentration. Water-quality samples generally were collected at three to four depths: one in the epilimnion, one as close as possible to the reservoir bottom without disturbing the bottom sediments, and one or two intermediate depths to define the vertical variation in chemistry. Water-quality sampling was conducted monthly from June through September 1994, and again in March 1995, just prior to ice off. In addition to the reservoir sites, streamflow data collected by the State of Colorado, Division of Water Resources, and the U.S. Geological Survey from two sites located on the Alamosa River, AR 31.0, Alamosa River downstream from Terrace Reservoir (USGS site identification number 08236500), and AR 34.5, Alamosa River upstream from Terrace Reservoir (USGS site identification number 08236000) were used to provide information on flow into and out of the reservoir. At AR

34.5, inflow chemistry (Patrick Edelmann and Sheryl Ferguson, U.S. Geological Survey, written commun., 1996), and diurnal (over a 24-hour period) variations of water temperature, specific conductance, and pH of water flowing into Terrace Reservoir were sampled. Samples for the analysis of the inflow chemistry were collected in conjunction with reservoir sampling. Reservoir profile data are available through the U.S. Geological Survey, and reservoir chemistry data are available through the U.S. Environmental Protection Agency.

### **FACTORS AFFECTING DISTRIBUTION OF METAL CONCENTRATIONS**

Several factors potentially can affect the distribution of metal concentrations in the water column of Terrace Reservoir (Robert Stogner and Patrick Edelmann, U.S. Geological Survey, written commun., 1996). These factors include the physical and chemical characteristics of the inflow and the physical, chemical, and biological characteristics of the reservoir (fig. 2). Changes in streamflow, water temperature, dissolved-oxygen concentrations, pH, and concentrations of metals in the Alamosa River upstream from the reservoir (Patrick Edelmann and Sheryl Ferguson, U.S. Geological Survey, written commun., 1996) affect the distribution of metal concentrations in the water column of Terrace Reservoir.

Physical processes within Terrace Reservoir that affect distribution of metal concentrations in the water column include thermal stratification, inflow routing and flow-through patterns, reservoir residence times, and the deposition of particulate matter (Robert Stogner and Patrick Edelmann, U.S. Geological Survey, written commun., 1996). Thermal stratification of the reservoir resulted in limited or inhibited vertical mixing between limnetic layers and enhanced horizontal movement within the various limnetic layers. Inflow from the Alamosa River is initially routed to various depths within the reservoir because of density differences between the inflow and reservoir water column. The initial flow routing and the flow-through patterns within the reservoir affect the reservoir residence time of inflowing water. During periods of stratification, water that was routed to the hypolimnion as underflow moved through the reservoir faster than epilimnetic water because the reservoir outlet is located on the bottom of the reservoir near the dam. Water with short residence times has less time for physical and chemical processes to affect metal concentrations of incoming water before being released downstream.

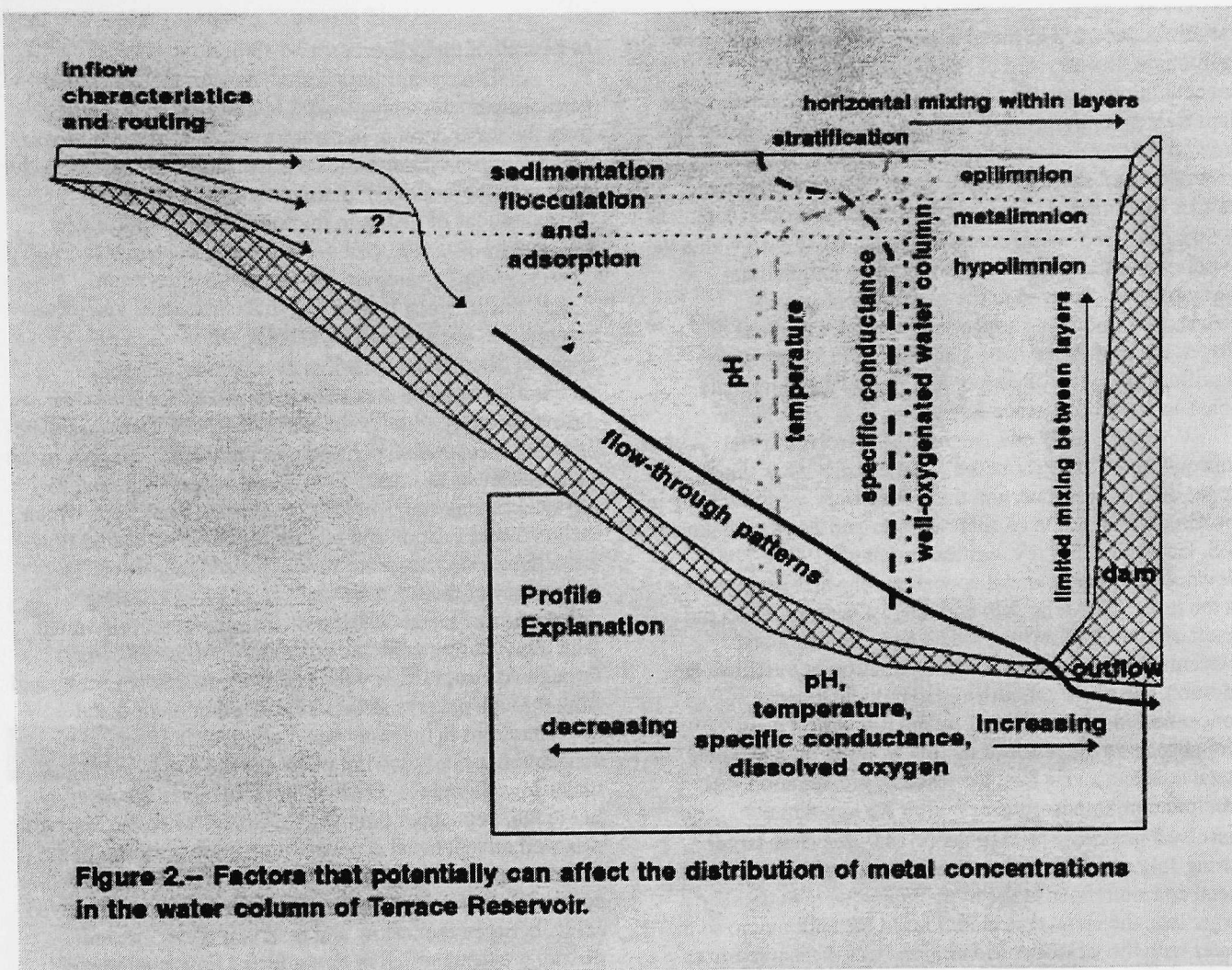

**Figure 2.— Factors that potentially can affect the distribution of metal concentrations in the water column of Terrace Reservoir.**

Deposition of particulate-metal concentrations significantly decreased the amount of particulate or suspended concentrations of metals in the water column in Terrace Reservoir. During collection of 30 reservoir-bottom sediment samples, A.J. Horowitz (U.S. Geological Survey, written commun., 1995) observed that “the bottom of the reservoir was covered by a thin, soupy, extremely fine-grained red-orange floc ... Based on color, it was inferred that the floc contained, or was composed of substantial quantities of iron oxide.” Based on these observations, a substantial amount of ferric hydroxide has settled out of the water column in Terrace Reservoir. As metals partition to the solid phase and settle from the water column, particulate-metal concentrations in the reservoir water column decrease.

### CHEMICAL CHARACTERISTICS

During the study period, the concentration of dissolved oxygen varied longitudinally, vertically, and temporally in response to changes in water temperature. The Alamosa River provided a consistent supply of well-oxygenated water to the reservoir. Dissolved-oxygen concentrations in the reservoir were generally within 0.5 mg/L of the dissolved-oxygen concentration of the inflow. The pH of the water in the reservoir generally ranged from

about 4.0 to 7.0, depending upon time, depth, and location. The highest pH values were measured during May 1994 and May 1995, which coincided with snowmelt runoff. During periods of thermal stratification, May through August, pH generally decreased with depth. Fall turnover in September generally mixed the reservoir waters, and pH was generally uniform with depth through November; however, pH continued to be higher in the upstream reach of the reservoir. During February and March 1995, pH of the reservoir water increased with depth and time.

### Metal Chemistry

Dissolved- and total-recoverable-metal concentrations varied spatially and temporally in response to inflow characteristics and physical processes in Terrace Reservoir. For the purpose of the study, dissolved metal was defined as metal that passed through a 0.45- $\mu$ m filter. However, numerous investigations of trace-element chemistry have indicated that water filtered through a 0.45- $\mu$ m filter may contain substantial amounts of colloidal trace elements (Kimball and others, 1995; Horowitz and others, 1996). The dissolved-metal fraction was the dominant phase observed in the reservoir.

During June, large longitudinal and vertical

variations occurred in metal concentrations. In the epilimnion, the elevated pH and decrease in metal concentrations from the upstream end of the reservoir to the dam was indicative of differences in chemistry of water that entered the reservoir at different times. As a result of underflow and short residence times (Robert Stogner and Patrick Edelmann, U.S. Geological Survey, written commun., 1996), dissolved-metal concentrations ( $<0.45 \mu\text{m}$ ) within the hypolimnion exhibited considerably less longitudinal variation than occurred in the epilimnion. Limited geochemical modeling suggested that concentrations of suspended particulate matter and pH were too small for significant sorption of copper and zinc to the particulate phase to occur in Terrace Reservoir.

During July and August, the dissolved-metal concentrations throughout the water column were generally larger than during June, and the metals were predominantly in the dissolved fraction (Robert Stogner and Patrick Edelmann, U.S. Geological Survey, written commun., 1996). The elevated epilimnetic metal concentrations that were present in the reservoir during July and August were probably the result of mixing of inflow, which had elevated metal concentrations, that entered the epilimnion as overflow. In addition, the small variations in longitudinal metal concentrations that occurred during this period were probably more the result of mixing of water with different metal concentrations than the result of precipitation, co-precipitation, or adsorption. Within the hypolimnion, dissolved-metal concentrations ( $<0.45 \mu\text{m}$ ) were larger during July and August than during June, and the dissolved-metal concentrations in the hypolimnion were noticeably larger than the metal concentrations in the epilimnion; so the water with the largest concentrations was discharged from the reservoir.

During September, metal concentrations were significantly larger in the downstream part of the reservoir than in the upstream part, and little vertical variation in metal concentrations occurred in the downstream part of the reservoir. In the upstream part of the reservoir, iron and aluminum were largely in the particulate fraction, and copper, cadmium, manganese, and zinc were largely in the dissolved fraction ( $<0.45 \mu\text{m}$ ). In the downstream part of the reservoir, all metals were predominantly in the dissolved fraction. During September, mixing strongly affected metal concentrations, as metal concentrations measured during September equaled average metal concentrations measured during August.

During January, February, and March, the reservoir was covered with ice and weakly stratified due to density gradients created by differences in concentrations of dissolved solids between the inflow and reservoir water. In March, reservoir chemistry varied both longitudinally and vertically. The dissolved-metal concentrations in the reservoir during March were generally less than the concentrations measured in the reservoir during September. The largest metal concentrations occurred in the epilimnion. Large decreases in metal concentration occurred with depth

as a result of underflow.

During the study period, most of the suspended particulate matter and colloidal metal hydroxides settled from the water column in the upstream part of the reservoir. The deposition of suspended particulate matter substantially decreased the amount of particulate or suspended concentrations of metals in the water column in Terrace Reservoir.

## DISCUSSION

The dominant factors or processes affecting distribution of metal concentrations in Terrace Reservoir during the study were 1) streamflow, temperature, dissolved-oxygen concentration, pH, and concentrations of metals in the Alamosa River upstream from Terrace Reservoir, and 2) physical factors and processes in Terrace Reservoir, which included stratification and mixing, inflow-routing and flow-through patterns, residence times, and sedimentation. The importance of these factors and processes in affecting distribution of metal concentrations in the reservoir varied with time. During periods of thermal stratification, May through August, mixing within layers, initial flow-routing and flow-through patterns affected the distribution of metal concentrations in the reservoir. Variations in metal concentrations in inflowing water and the dominance of underflow altered the distribution of metals in the reservoir. In the fall, September through November, when the reservoir was well mixed, metal concentrations were uniform. In the winter, January through March, when the reservoir was covered with ice, differences in concentrations of dissolved solids between the inflow and reservoir water created density gradients which in turn affected flow routing and distribution of metal concentration.

Attenuation of metal concentrations in the water column in Terrace Reservoir was due to sedimentation of suspended particulate matter and colloidal metal hydroxides in the upstream part of the reservoir. The limited data collected during the study suggest that attenuation of metal concentrations by adsorption or precipitation was not substantial and resulted in little if any changes in dissolved metal concentrations.

## SELECTED REFERENCES

- Britton, L.J., and Wentz, D.A., 1980, Water-quality characteristics of selected lakes and reservoirs in Colorado: U.S. Geological Survey Open-File Report 80-436, 139 p.
- Horowitz, A.J., Lum, K.R., Garbarino, J.R., Hall, G.E.M., Lemieux, C., and Demas, C.R., 1996, Problems associated with filtration to define dissolved trace element concentrations in natural waters: *Environmental Science and Technology*, v. 30, p. 954-963.
- Kimball, B.A., Callender, E., and Axtmann, E.V., 1995,

Effects of colloids on metal transport in a river receiving acid mine drainage, upper Arkansas River, Colorado, U.S.A.: Applied Geochemistry, v. 10, p. 285-306.

King, T.V.V., 1995, Environmental considerations of active and abandoned mine lands: U.S. Geological Survey Bulletin 2220, 38 p.

U.S. Environmental Protection Agency, 1993, Summitville mine removal action, site summary, Denver, Colo.

Walton-Day, Katherine, Ortiz, R.F., and von Guerard, P.B., 1995, Sources of water having low pH and elevated metal concentrations in the upper Alamosa River from the headwaters to the outlet of Terrace Reservoir, south-central Colorado, April-September, 1993, in Posey, H.H., Pendleton, J.A., and Van Zyl, D.J.A., eds., Proceedings, Summitville Forum '95: Denver, Colorado Geological Survey Publication 38, p. 160-170.

Woodling, J.D., 1995, Historic fisheries records -- Alamosa River, in Posey, H.H., Pendleton, J.A., and Van Zyl, D.J.A., eds., Proceedings, Summitville Forum '95: Denver, Colorado Geological Survey Special Publication 38, p. 228-235.



# EVALUATION OF METAL TRANSPORT INTO AND OUT OF TERRACE RESERVOIR, CONEJOS COUNTY, COLORADO, APRIL 1994 THROUGH MARCH 1995



By

Sheryl A. Ferguson

U.S. Geological Survey, WRD

201 W. 8th Street, Suite 200

Pueblo, Colorado 81003

## INTRODUCTION

Terrace Reservoir is a small irrigation reservoir located on the Alamosa River in the San Juan Mountains near Capulin, Colorado (fig. 1). The Alamosa River and Terrace Reservoir are the primary sources of water for crops and livestock in the southwestern part of the San Luis Valley. Much of the drainage basin upstream from Terrace Reservoir contains extensive areas of hydrothermally altered rocks that contribute a substantial metal load to Terrace Reservoir. Significant gold mining activities have occurred intermittently at the Summitville mine, and historically highly acidic, metal-enriched water has drained from the mine site into Wightman Fork, a tributary of the Alamosa River, where it flows into

Terrace Reservoir. The drainage waters from the Summitville mine generally have a pH less than 3 and have contained high concentrations of aluminum, copper, zinc, and other metals (King, 1995). In 1992, the operator of the Summitville mine declared bankruptcy, and the U.S. Environmental Protection Agency (USEPA) took over operation of the water-treatment facility at the mine. Preliminary ecological and human-health risk assessments indicated that the concentrations of total and dissolved aluminum, cadmium, copper, iron, manganese and zinc were high enough to be of environmental concern. In 1994, the U.S. Geological Survey (USGS), in cooperation with the USEPA, began a study as part of risk assessment and remediation efforts to evaluate metal transport into and out of Terrace Reservoir.

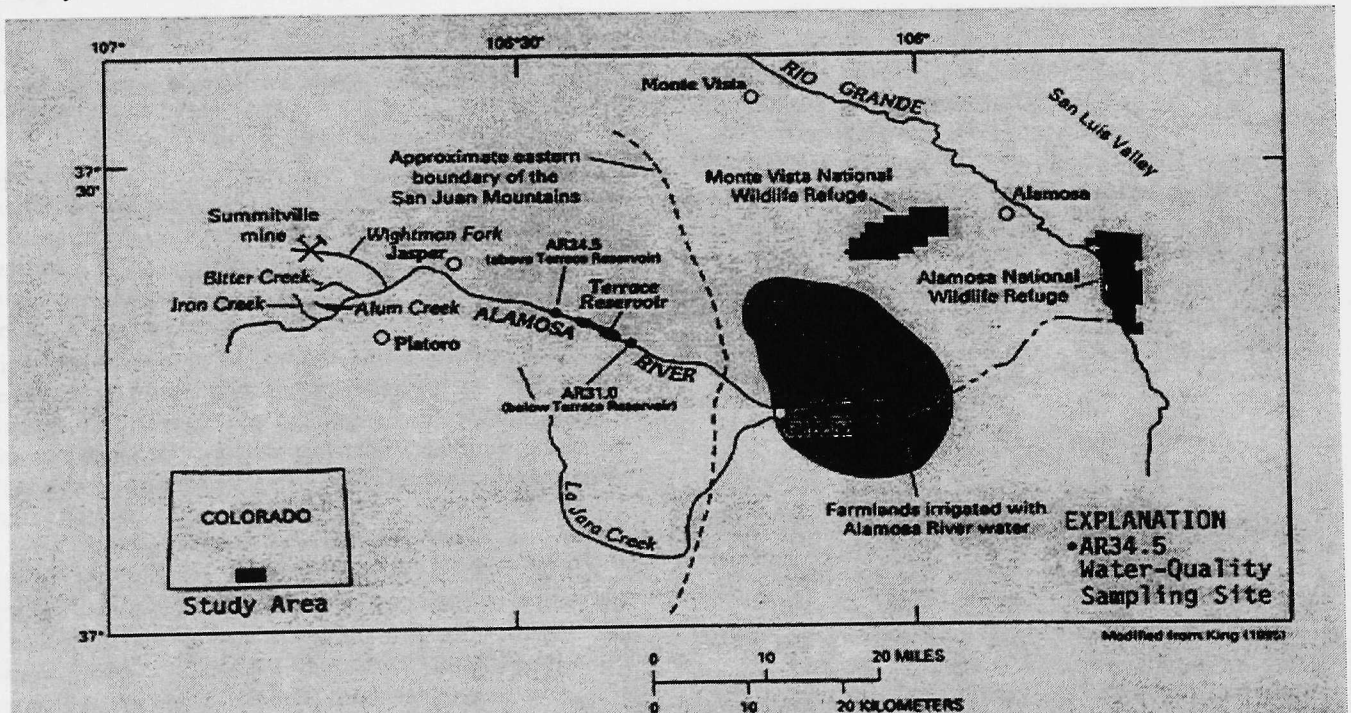

Figure 1.-- Location of study area and water-quality sampling sites.

Previous studies of water quality indicate that Wightman Fork is the predominant source of aluminum, copper, iron, manganese, and zinc during peak and post-snowmelt peak periods, and the source of most of the copper, manganese, and zinc during most of the year (Walton-Day and others, 1995). In addition to mining as a source of contamination, degradation of the water quality of the Alamosa River has occurred from natural sources of acidity and metals. The Alamosa River upstream from Iron Creek contains only moderate concentrations of aluminum and iron and very minor amounts of copper, manganese, and zinc (Walton-Day and others, 1995); however much of the dissolved aluminum, iron, and most of the copper, manganese, and zinc in the Alamosa River upstream from the confluence with Wightman Fork is the result of natural processes (Kirkham, and others, 1995).

## **APPROACH**

Two water-quality sampling sites, AR34.5, Alamosa River above Terrace Reservoir (USGS site identification number 08236000), and AR31.0, Alamosa River below Terrace Reservoir (USGS site identification number 08236500) were selected for study to describe the metal chemistry and evaluate metal transport into and out of Terrace Reservoir (fig. 1). These sites were selected because of their proximity to the reservoir, and both sites are currently operated as streamflow-gaging stations by the State of Colorado, Division of Water Resources. The gaging station downstream from the reservoir is operational during the entire year; the gaging station upstream from the reservoir is operational from approximately March through mid-November. The gaging stations provide continuous streamflow records used to compute metal loads. During April 1994 through March 1995, 36 water samples were collected at AR34.5 to evaluate metal transport entering the reservoir, and 23 samples were collected at AR31.0 to evaluate metal transport out of the reservoir. The samples were collected using the equal-width increment method which results in a representative constituent concentration for the entire river cross section (Edwards and Glysson, 1988; Ward and Harr, 1990). Samples were collected and processed using standard USGS methods. Chemical analyses were done by a USEPA contract laboratory. The samples were analyzed for dissolved (filtered through a 0.45-micron filter) and total (whole water) metals. Additional samples were collected at AR34.5 using an automatic sampler at a single point within the river cross section during rainfall-runoff events.

## **METAL LOADS**

Metal loads were computed to estimate the

quantity of metals that were transported into and out of Terrace Reservoir between April 1994 and March 1995. Loads were computed using a modified time-interval method. In this method, the data record was divided into several discrete time intervals based on changes in metal concentration, streamflow, or events (such as snowmelt-runoff or storms). The mean metal concentration for each time interval was multiplied by the mean daily streamflow from the streamflow gaging station to determine daily metal loads. Daily metal loads were summed into seasonal and annual metal loads. Because metal loads are a function of concentration and streamflow, loads varied considerably as a result of changes in stream-flow and/or changes in metal concentration. The largest loads occurred during the peak snowmelt runoff period (mid-May through mid-June), and the post-snowmelt peak runoff period (mid-June through mid-July). Substantial metal loading also occurred during storm events. The smallest metal loads occurred during the winter (November through February) when streamflow was greatly reduced.

### **Aluminum**

Large variations in aluminum loads occurred during the study. The largest daily loads of aluminum were transported into and out of Terrace Reservoir during the peak snowmelt period between mid-May through mid-June (fig. 2). The maximum daily total-aluminum load that entered the reservoir was about 11 tons (fig. 2). An estimated 81 percent of the 363 tons of total aluminum that entered the reservoir during the study period remained in the reservoir, indicating that the reservoir was a sink for an estimated 295 tons of aluminum (table 1). Only 68 tons of total aluminum load were transported out of the reservoir during the study period, primarily during the peak snowmelt period. Almost all of the total-aluminum load that entered the reservoir during the winter (October through March) remained in the reservoir.

### **Iron**

The largest daily iron loads were transported into and out of Terrace Reservoir during the peak snowmelt period, and the maximum daily total-iron load that entered the reservoir was about 25 tons (fig. 2). About 76 percent of the 790 tons of total iron that entered the reservoir during the study period remained, indicating that the reservoir was a sink for about 597 tons of iron (table 1). Most of 193 tons of iron that was discharged out of the reservoir was transported downstream during the peak and post-snowmelt peak periods, from mid-May through mid-July (fig. 2).

### **Copper**

The maximum daily total-copper load of about 1.9 tons entered the reservoir on June 8, about a week

later than the maximum daily total-aluminum and total-irons loads and was substantially smaller than the daily total- aluminum and iron loads (fig. 2). The largest daily total-copper loads were transported into and out of the reservoir during the post-snowmelt peak period (mid-June through mid-July) (fig. 3). During the study period, an estimated 61 tons of total copper entered the reservoir, approximately 39 tons of total copper was discharged downstream to the Alamosa River, and an estimated 22 tons of total copper remained in the reservoir (table 1).

### **Manganese**

The largest daily manganese loads were transported into and out of Terrace Reservoir during the peak snowmelt runoff period (fig. 3). The maximum daily total-manganese load that entered the reservoir was slightly more than 1 ton (fig. 3) and occurred at the same time as the maximum daily total-aluminum and daily total-iron loads, and a week before the maximum daily total-copper load. Large manganese loads also were transported into the reservoir during storm events during the summer months and were not transported out of the reservoir during that time. An estimated 52 tons of total-manganese were transported into the reservoir, and about 90 percent (47 tons) of manganese load were transported out, indicating that the reservoir was a sink for only a small amount (5 tons) of total manganese (table 1).

### **Zinc**

The maximum daily total-zinc load of about half a ton entered the reservoir on June 8, 1994, the same date as the maximum total-copper load, and near the end of the peak snowmelt runoff period (fig 4). Ninety percent of the 20 tons of total-zinc load that entered the reservoir was transported out, and more than half of the total-zinc load was transported downstream during the peak-snowmelt and post- snowmelt-peak periods of mid-May through mid-July (table 1).

## **DISCUSSION**

Metal loads in the Alamosa River upstream and downstream from Terrace Reservoir varied seasonally

as a result of changes in streamflow and changes in metal concentrations. The largest daily loads of total-aluminum, iron, and manganese were transported into and out of the reservoir during the peak snowmelt period (mid-May through mid-June) and the smallest loads occurred during the winter months (November through February). The largest daily copper and zinc loads also occurred during the peak snowmelt-runoff period but approximately one week later than the maximum daily loads for aluminum, iron, and manganese.

## **SELECTED REFERENCES**

- Edwards, T.K., and Glysson, G.D., 1988, Field methods for measurement of fluvial sediments: U.S. Geological Survey Open-File Report 86-531, 118 p.
- King, T.V.V., ed., 1995, Environmental considerations of active and abandoned mine lands: U.S. Geological Survey Bulletin 2220, 38 p.
- Kirkham, R.M., Lovekin, J.R. and Sares, M.A., 1995 Sources of acidity and heavy metals in the Alamosa River basin outside of the Summitville mining area, Colorado, *in* Posey, H.H., Pendleton, J.A., and Van Zyl, D., eds., Proceedings: Summitville Forum '95: Denver, Colorado Geological Survey Special Publication 38, p. 42-57.
- Walton-Day, Katherine, Ortiz, R.F., and von Guerard, P.B., 1995, Seasonal variations in water quality on Wightman Fork of the Alamosa River, 1993, *in* Posey, H.H., Pendleton, J.A., and Van Zyl, D., eds., Proceedings: Summitville Forum '95: Denver, Colorado Geological Survey Special Publication 38, p. 160-170.
- Ward, J.R., and Harr, C.A., eds., 1990, Methods for collection and processing of surface-water and bed material samples for physical and chemical analyses: U.S. Geological Survey Open-File Report 90-140, 71 p.



**Table 1. Annual and selected seasonal total metal loads (in tons)  
at AR34.5 and AR31.0, April 1, 1994, through March 31, 1995**

SITE	METAL	PEAK SNOWMELT PERIOD (mid-May through mid-June, 1994)	POST- SNOWMELT PEAK PERIOD (mid-June through mid-July 1994)	SUMMER AND STORM SEASON (mid-July through September, 1994)	TOTAL ANNUAL LOAD (April 1, 1994 through March 31, 1995)
AR34.5	Total Aluminum	165	55	71	363
AR31.0	Total Aluminum	43	8	8	68
	Difference	+122	+47	+63	+295
Diff					
AR34.5	Total Iron	376	125	143	790
AR31.0	Total Iron	93	48	28	193
	Difference	+283	+77	+115	+597
Diff					
AR34.5	Total Copper	16.9	26	12.1	61
AR31.0	Total Copper	5.4	17	11.6	39
	Difference	+11.5	+9	+0.5	+22
Diff					
AR34.5	Total Manganese	18.1	11.1	10	52
AR31.0	Total Manganese	14.0	10.8	11	47
	Difference	+4.1	+0.3	-1	+5
Diff					
AR34.5	Total Zinc	6.0	6.8	3.6	20
AR31.0	Total Zinc	4.6	6.0	4.1	18
	Difference	+1.4	+0.8	-0.5	+2
Diff					

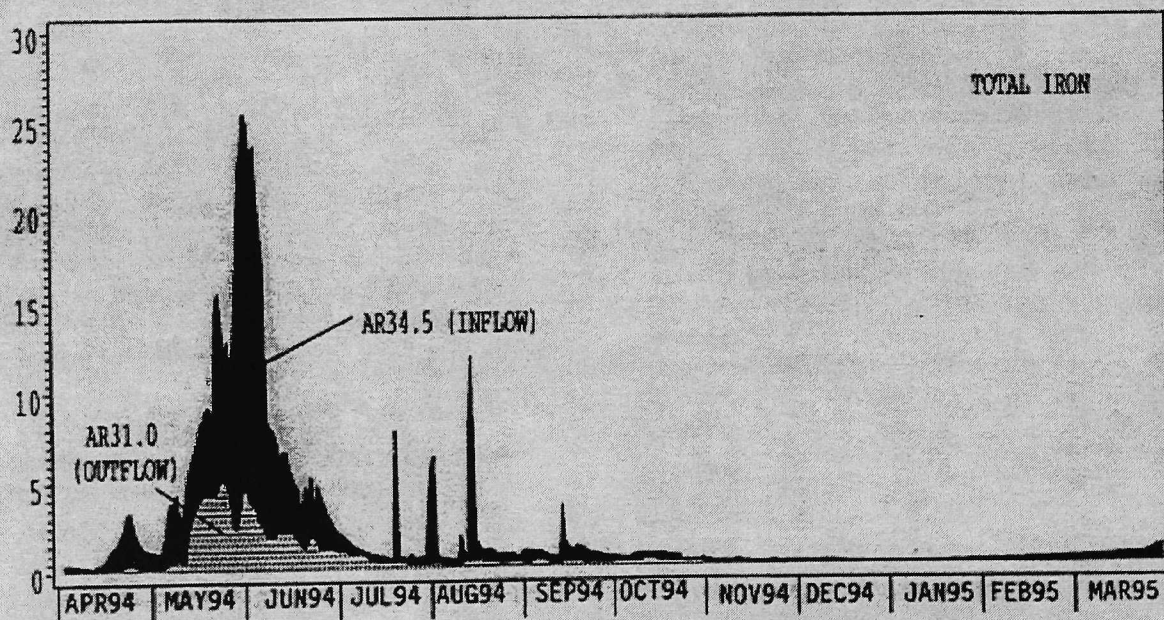
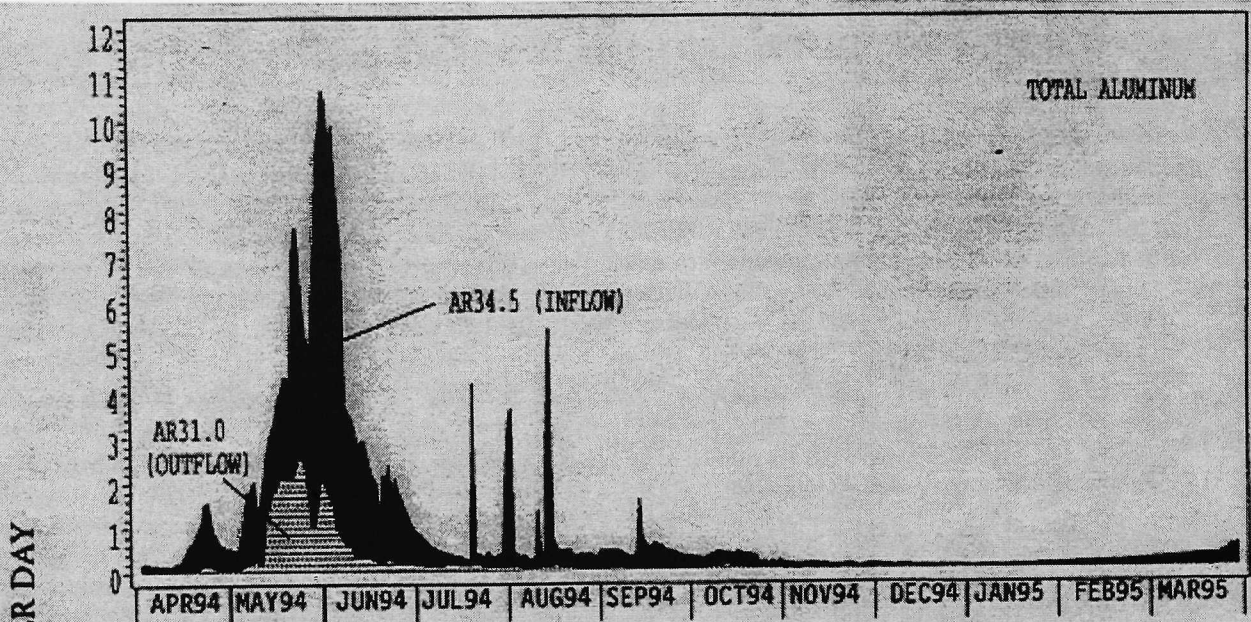

Figure 2. -- Daily total-aluminum and total-iron loads upstream (AR34.5) and downstream (AR31.0) of Terrace Reservoir, April 1994 through March 1995.

LOADS IN TONS PER DAY

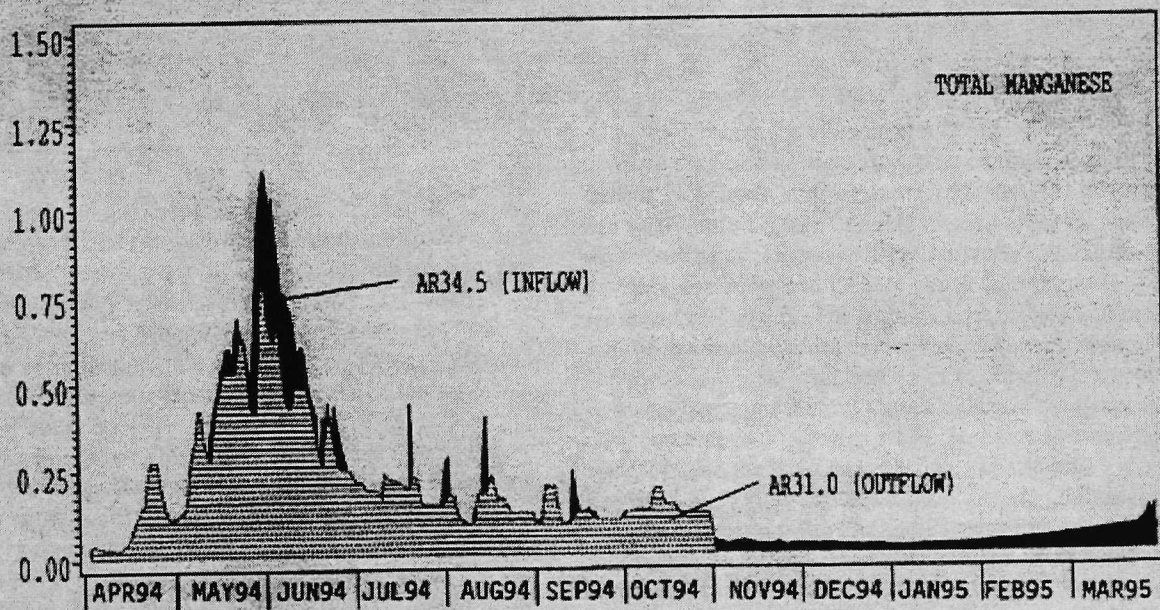
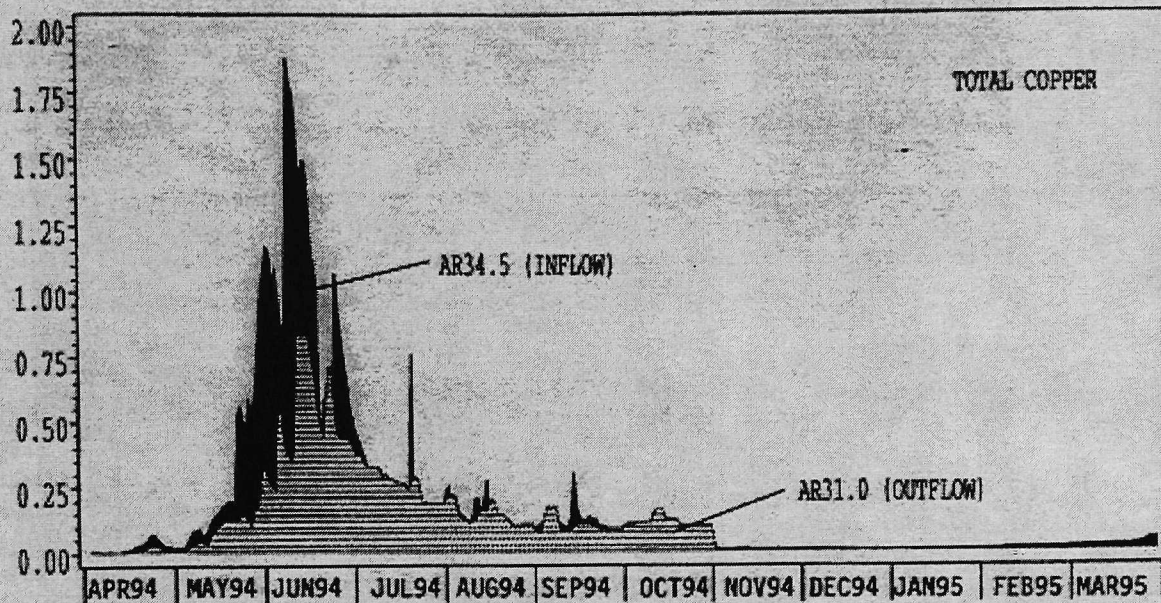

Figure 3. -- Daily total-copper and total-manganese loads upstream (AR34.5) and downstream (AR31.0) of Terrace Reservoir, April 1994 through March 1995.

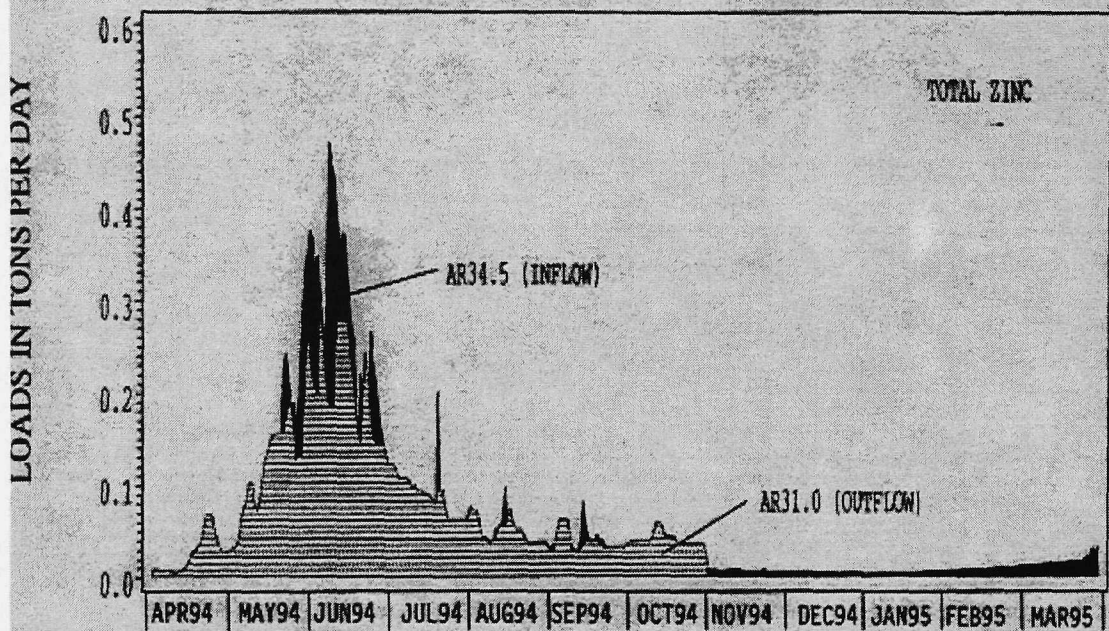

Figure 4. -- Daily total-zinc loads upstream (AR34.5) and downstream (AR31.0) of Terrace Reservoir, April 1994 through March 1995.

# The Alamosa River Irrigation System Western Central San Luis Valley, Colorado



By  
Susan Ford and David Skidmore  
Morrison Knudsen Corporation  
7100 E. Belleview Avenue, Suite 300  
Englewood, CO 80111

## INTRODUCTION

This paper explains the irrigation system below Terrace Reservoir and its potential to impact La Jara Creek, the Rio Grande River, the Alamosa National Wildlife Refuge, and the Monte Vista National Wildlife Refuge. The irrigation system includes water from Terrace Reservoir via the Alamosa River and numerous diversion ditches; water from the upper Rio Grande River via the Monte Vista Canal and the Empire Canal; water from La Jara Creek; water from irrigation wells; and water from ground water recharge to the Alamosa River, La Jara Creek and various ditches.

For the purpose of this document, "Alamosa River water" refers to water from Terrace Reservoir that has not been diluted by other sources. Water in the Alamosa River from Road 15 east is considered to be significantly diluted by other sources and will be referred to in this document as "Alamosa mixed water." For convenience, Highway 285 (HWY 285) is used to designate areas of the irrigation system. There is no hydrologic or geologic significance to this designation.

## DESCRIPTION

The Alamosa River receives heavy metal and acidic constituents from several geologic structures and mines. On the north side of the Upper Alamosa River Basin, Alum Creek, Iron Creek and Bitter Creek contribute waters that contain low pH and high metals as they drain these geologic structures. Water quality from the south side of the basin is generally of better quality.

Wightman Fork drains the Summitville Mine Site on the north and receives additional volume from Cropsy Creek, which drains the south side of the Mine Site. Approximately eleven miles downstream from its confluence with Wightman Fork (nine miles northwest of Centro, Colorado), the Alamosa River flows into Terrace Reservoir. Terrace Reservoir stores irrigation water used in the Western Central San Luis Valley. The Alamosa River only flows below this structure when water is released for irrigation and flood control.

The Alamosa River irrigation system consists of thirty-eight diversion structures. Table 1 presents the diversion structures from Terrace Reservoir east along the Alamosa River and includes approximate size, estimated capacity,

priority<sup>1</sup>, decreed amount<sup>2</sup>, and location with respect to the Alamosa River. The owners of El Viejo Ditch hold the number one priority.

Thirty of these diversion structures are located west of Hwy 285, which runs north-south between Antonito and Alamosa (see Figure 1). The size of these ditches ranges from the Terrace Main Canal, a truncated triangular ditch approximately 6 feet wide and 3 feet deep, to the San Jose No. 2, a small channel approximately one foot wide and eight inches deep. The volume of water carried in these ditches varies from a twelve-year average of 33.40 cubic feet per second (cfs) in the Terrace Main Canal to a twelve-year average of 1.47 cfs in the San Jose No. 2 (see Table 2). These diversions direct water north and south of the Alamosa River.

Two surface water bodies in the area that may be impacted by Alamosa River water include Hot Creek and La Jara Creek. Hot Creek is located approximately four miles south of the Alamosa River. The Valdez Ditch flows from the Alamosa River south towards Hot Creek, though it is usually diverted for farming uses prior to its confluence with Hot Creek. Hot Creek joins La Jara Creek just east of Centro. At this confluence La Jara Creek is located approximately one mile south of the Alamosa River. Several diversions connect the Alamosa River and La Jara Creek (see Figure 1). They are listed in Table 3. The implications of these diversions will be discussed under the Nature and Extent Section below.

Other sources of irrigation water in the area are ground water recharge, the Monte Vista Canal and the Empire Canal. The percentage of artesian wells increases in areas near Hwy 285 and the Rio Grande River. The Monte Vista and Empire Canals flow southeast from the Rio Grande River, contain exclusively Rio Grande River water, are unlined, and intersect the Alamosa River channel. It is probable that direct recharge

---

<sup>1</sup>In western water law, water is allocated based on priority or the ranking of the owner based on the water right filing date therefore, the oldest adjudicated water right is highest on the seasonal priority

<sup>2</sup>The decreed amount is the total volume of water allotted by adjudication to a water right owner.

from ground water to the Alamosa River also occurs. Additional discussion of these intersections follows in Nature and Extent Section. Figure 2 presents a flow chart of all known water sources in the area and direction of flow.

## WATER USE

The Alamosa River is used to irrigate approximately 45,000 acres in the San Luis Valley (Erdman et.al, 1995). Water usage is distributed among the thirty-eight diversion ditches based on priority, but the largest flow of the water is conducted along the Terrace Main Canal. Twenty of the thirty-eight ditches have a priority of 38 or lower.

Table 2 presents information on all ditches with priority 38 and lower; these are the ditches that are likely to carry the most water for the longest periods of time. Volume is presented in acre-feet to coincide with the legal record. Where listed in the records, the rate in cubic feet per second is noted. The blank cells in the table indicate that no recorded flow from the Alamosa River occurred during that month in the diversion. The reader should note that runoff from precipitation events may flow through these ditches at any time.

The water rights for Terrace Reservoir were recorded in the late 1890's with adjudication in the early 1900's. The reservoir infrastructure was completed during the 1920's with replacement of the metering valve for irrigation waters during 1982. The existing physical capacity of the reservoir is 15,182 acre-feet when the reservoir is filled to the lip of the emergency spillway. The current 100-year flood event safety limitation water level is seven feet below the emergency spillway. Therefore, the maximum capacity under this restraint is about 13,150 acre-feet. The metered valve for the Alamosa River irrigation system draws water from the bottom of Terrace Reservoir. No sediment/de-silting mechanism is in place to prevent silt or sediments from being transported by the irrigation system to the irrigated fields (MK, 1994/1995). Terrace Main Irrigation Company estimates the remaining economic life of Terrace Reservoir to be in excess of 100 years.

Below the Terrace Reservoir dam, the unlined Alamosa River channel is used as a conduit for all metered irrigation waters, spring runoff excesses, and emergency spillway releases. Terrace Main Irrigation Company and the Colorado Department of Water Resources have tested the Alamosa River channel from the Terrace Reservoir dam down to Gunbarrel Road to determine the loss of water. These tests indicate that an average water loss of 13 to 15 percent due to infiltration through this part of the system.

Each spring the water is released to diversions upon demand by the farmers in the irrigation system. The date of initial yearly release depends on the amount of precipitation received by the potentially irrigated lands during the winter and spring. Water release occurs as early as the first of March and as late as the end of April. Flow continues in certain high priority canals as late as December. This release falls under the responsibility of the Colorado

Division of Water Resources, Division 3, District 21. Water is allowed to flow between sources via intra-division agreements and adjudicated instructions of water rights (MK, 1994/1995).

## NATURE AND EXTENT OF ALAMOSA RIVER WATER

Few data are available that document the transport of impacted water throughout the Alamosa River irrigation system<sup>3</sup>. Based on field observations, the pH appears to remain constant from Terrace Reservoir to the headgates along the Alamosa River west of Road 15 (MK, 1995). Farther downstream, the water chemistry is influenced by runoff, return flow, flowing wells, and Rio Grande River irrigation water.

The irrigated area served by the Alamosa River will be discussed as three categories: the Alamosa River and diversions west of Hwy 285 that do not transfer water to La Jara Creek; diversions west of Hwy 285 that transfer water to La Jara Creek; and the Alamosa River and diversions east of Hwy 285 (See Figure 2).

### West of Hwy 285-No Transfer

Thirty diversions exist west of Hwy 285. The majority of these divert water from the Alamosa River to irrigated fields (six of these ditches are discussed in the next section). These diversions flow both north and south of the Alamosa River and end at irrigated fields without intersecting other surface water bodies in the area. The extent of land irrigated by Alamosa River water is depicted in Figure 1. Media that have the potential to be impacted by the Alamosa River include ground water and soil as well as the irrigated crops.

Flood irrigation is used throughout this area of the San Luis Valley and the water table often rises within 2 cm of the ground surface at the beginning of the growing season (Emery et al., 1971). Therefore, the potential exists for contact between infiltrating irrigation water and ground water. However, data collected to date do not indicate an impact to the ground water along the Alamosa River from direct river/ditch recharge to the aquifer or irrigation infiltration (MK, 1994/1995).

The Terrace Main receives the largest quantity of water of all the canals west of Hwy 285 and conducts it to the north. Along its length there are several eastern laterals, but the Terrace Main Canal ends at Tenmile Road with four headgates for two holding ponds and two diversions (north and east). The north diversion is unlined and approximately one mile long. It terminates (is allowed to infiltrate) on the south end of an irrigated field. This field is also irrigated with well water and borders the south bank of the Monte Vista Canal.

There was concern that impacted Alamosa River water

<sup>3</sup>Water chemistry is measured sporadically at AR-31.0 and along the divisions. See Figure 1 for locations.

might reach the Monte Vista National Wildlife Refuge located approximately 3/4 miles north of the Monte Vista Canal. However, an irrigated field of approximately 80 acres acts as a dilution source to any water that flows north from the Terrace Main lateral, and the Monte Vista Canal acts as a barrier between the wildlife refuge and any potentially impacted Alamosa River water. It is assumed that the Monte Vista Canal would carry any infiltration or runoff downstream to the southeast, though this has not been confirmed (the subsurface gradient near the Monte Vista Canal is not known).

Based on discussions with Colorado Division of Water Resources personnel, all east laterals from Terrace Main terminate and infiltrate in fields prior to meeting the Monte Vista Canal (MK, 1994/1995). Four laterals flow east from Terrace Main, along Tenmile Road, Elevenmile Road, Twelvemile road and between Elevenmile and Twelvemile Roads. (Note: These roads are numbered in successive miles south from Hwy 160.)

The USGS 7.5' topographic quadrangle for Capulin, Colorado indicates that the Monte Vista Canal intersects several irrigation ditches from the Alamosa River. At Road Z the Morganville and Flintham Ditches cross the Monte Vista Canal. The Flintham is conducted through the Monte Vista in a culvert. The cross-over for the Morganville is not evident, but it appears that the Morganville is conducted under the Monte Vista.

About one mile north of the Alamosa River on the Monte Vista Canal, the last of the allocated priorities terminates and reportedly, the flow from the Monte Vista Canal is fully utilized by the system. However, the channel/canal continues southward to Hwy 15, south of the Alamosa River and sometimes during high water/spring runoff, the water from the Alamosa River will backup into the Monte Vista Canal channel (MK, 1994/1995). Thus, there is a potential for the two water sources to commingle at a point about one mile north of the Alamosa River in the Monte Vista Canal channel.

During a reconnaissance in April 1995, it was noted that a large stretch of the Alamosa River was dry. Water was noted where the Gunbarrel Highway (Hwy 15) crosses the Alamosa River north of Centro. However, at Road 9 just east of Capulin, the Alamosa River was dry (see Figure 1). At Road 15 approximately six miles east of Road 9, the Alamosa River again contained water. Water with an approximate pH of 5.7 was present in the Alamosa River just west of Road 9. However, at Road 15 (approximately six miles east of Road 9) water was present in the Alamosa River and had an approximate pH of 6.7. It is probable that the water at Gunbarrel Highway is not chemically similar to the water present at Road 15. It is unknown how often segments of the Alamosa River are dry (MK, 1995).

## **West of Hwy 285-Transfer to La Jara/Hot Creek**

Colorado Division of Water Resources records and maps indicate that six ditches west of Hwy 285 may transfer water from Alamosa River to La Jara Creek. These ditches include Valdez, Gabino-Gallegos, Miller-Alamosa, Ramona, Garcia No. 2, Capulin, and El Viejo. Table 3 presents the volume of flow from Alamosa River into La Jara Creek during the 1982 through 1993 water years. The first-use date and last-use date are included to indicate the length of time water could be flowing in the ditches. This length ranges from one day (see Garcia No. 2 in 1991) to the growing season (numerous examples; see Miller-Alamosa for 1991). These ditches are not used continuously throughout the time between the first-use and last-use dates. Based on the data in Table 3, water flowed from the Alamosa River into La Jara Creek during each of the water years 1982 through 1993. A ratio of Alamosa River water to La Jara Creek water flowing in the La Jara creekbed cannot be made because the gage on La Jara Creek is located upstream near La Jara Reservoir and there is no gage to measure the additional volume from Hot Creek..

## **East of Hwy 285**

The Alamosa River irrigation system becomes more diluted by other water sources near Hwy 285. These influences include the Empire Canal, laterals from the Empire Canal, irrigation wells (some are flowing wells), springs, and runoff/precipitation. Based on a comparison of water rights with available flow in the Alamosa River, the Water Commission considers the Alamosa River to be completely allocated at Hwy 285, though flow may be present at this point. The Empire Canal intersects the Alamosa River at Hwy 285. There are no diversion structures at this confluence and the two water bodies flow together without human control.

Two diversions from the Alamosa River, but east of Hwy 285, route water south into La Jara Creek: Empire Canal-Alamosa and Lowland ditch. The majority of the water diverted via the Empire Canal-Alamosa originated in the Empire Canal; however, it has the opportunity to combine with Alamosa mixed water for approximately 500 feet while the Empire Canal uses the Alamosa streambed before the Empire Canal is diverted south at the Empire-Alamosa Diversion. The Lowland canal also diverts Alamosa mixed water south from the Alamosa River to La Jara Creek.

Spring runoff volumes too large for the Terrace Reservoir to safely contain and too large for irrigation use are released from the reservoir and allowed to flow east of Hwy 285. These flows collect and flood pastures behind a dike segregating the waters of the Alamosa River from the waters of the Rio Grande River. It is not known if this has occurred since 1987 when Summitville Consolidated began operations. It is probable that it occurred at least once in Spring 1993 due to the large snowpack of the 1992-1993 winter (MK, 1994/1995).

Other water movement east of Hwy 285 includes the Twenty-foot Lateral, the San Luis Valley Drain, and the Richfield Canal. The Twenty-foot Lateral diverts the majority of the water received at La Jara Creek from the Empire Canal. It is located approximately one mile downstream (east) from the confluence of the Empire Canal and La Jara Creek. Water from the Twenty-foot Lateral irrigates fields, but does not flow into the Rio Grande River.

The San Luis Valley Ditch diverts irrigation return flows from fields irrigated with Conejos River water and flows into the lower La Jara Creek. The Richfield Canal diverts Conejos River water into La Jara Creek west of both the Twenty-foot Lateral and the San Luis Valley Drain.

at domestic wells near Capulin, Colorado. Dated April 23-26, 1995.

Morrison Knudsen Corporation (1994/1995). Personal communications with Colorado Division of Water Resources personnel.



## SUMMARY

Observations of the Alamosa River irrigation system indicate that inputs to the system increase as water flows east from Terrace Reservoir. By the time water arrives at Hwy 285, there are approximately five influences: Alamosa River, La Jara Creek, Rio Grande River (Empire Canal and Monte Vista Canal), irrigation wells, and return flow from fields. Eight ditches transfer water from the Alamosa River to La Jara Creek between Terrace Reservoir and fields east of Hwy 285. At times, La Jara Creek may be impacted by Alamosa River water, however, it is probable that neither the Rio Grande River, the Alamosa National Wildlife Refuge, nor the Monte Vista National Wildlife Refuge are impacted.

## ACKNOWLEDGMENTS

The authors wish to acknowledge Jim Hanley and USEPA Region VIII for the funding of this paper. The authors also thank Colorado Department of Natural Resources, Division of Water Resources, Water Division Three for their assistance with this paper.

## REFERENCES

- Colorado Department of Natural Resources, Division of Water Resources, Water Division Three (1995). Diversion Summaries for the Alamosa River for the water years 1982 through 1993. Dated February 22, 1995.
- Emery, P.A., A.J. Boettcher, R.J. Snipes, & H.J. McIntire, Jr. (1971). Hydrology of the San Luis Valley, South-Central Colorado. USGS Hydrogeographic Investigations Atlas HA-381.
- Erdman, J.A., K.S. Smith, M.A. Dillon, & M. ter Kuile (1995). Impacts of Alamosa River water on alfalfa, southwestern San Luis Valley, Colorado in Proceedings: Summitville Forum '95. Colorado Geological Survey Special Publication 38.
- Morrison Knudsen Corporation (1995). Logbook for sampling

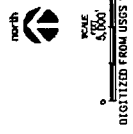
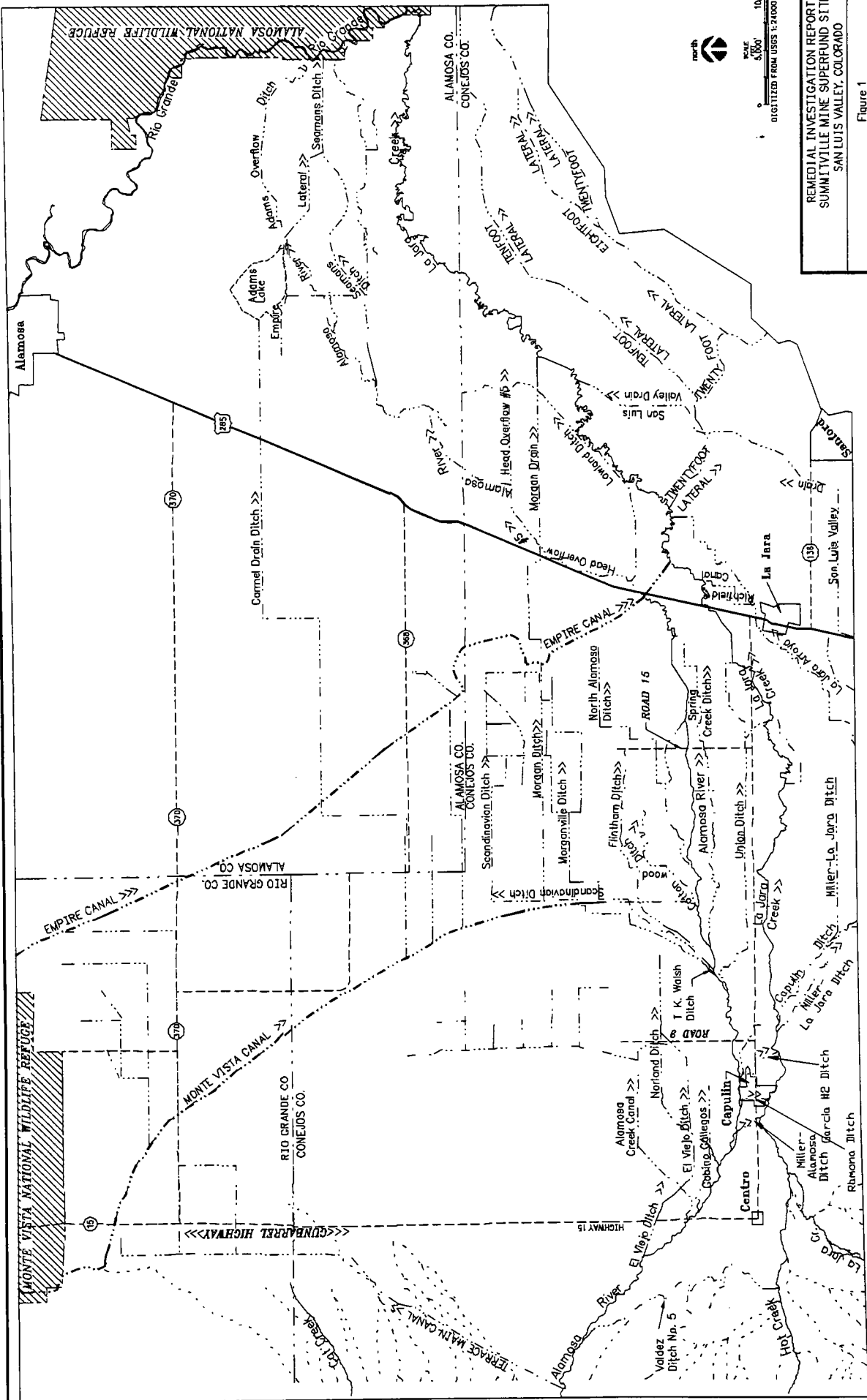

REMEDIAL INVESTIGATION REPORT  
 SUMMITVILLE MINE SUPERFUND SITE  
 SAN LUIS VALLEY, COLORADO

Figure 1  
 CURRENT UNDERSTANDING  
 WESTERN CENTRAL SAN LUIS VALLEY  
 IRRIGATION SYSTEM

APCS  
 Regions VI, VII, VIII  
 US Environmental Protection Agency

MORRISON KNUDSEN CORPORATION

FILE NAME (GAD)	012HO27A.DWG	DATE	5/13/96
WORK ORDER	3780-2718	TASK	122H
		DRAWING NUMBER	FIGURE 1
		REV.	A
		P.	

- LEGEND**
- CANALS/DITCHES
  - COUNTY LINE
  - - - INTERMITTENT STREAMS
  - ~~~~~ RIVERS/STREAMS

WATER SOURCES IN WESTERN CENTRAL SAN LUIS VALLEY

MINOR SOURCE

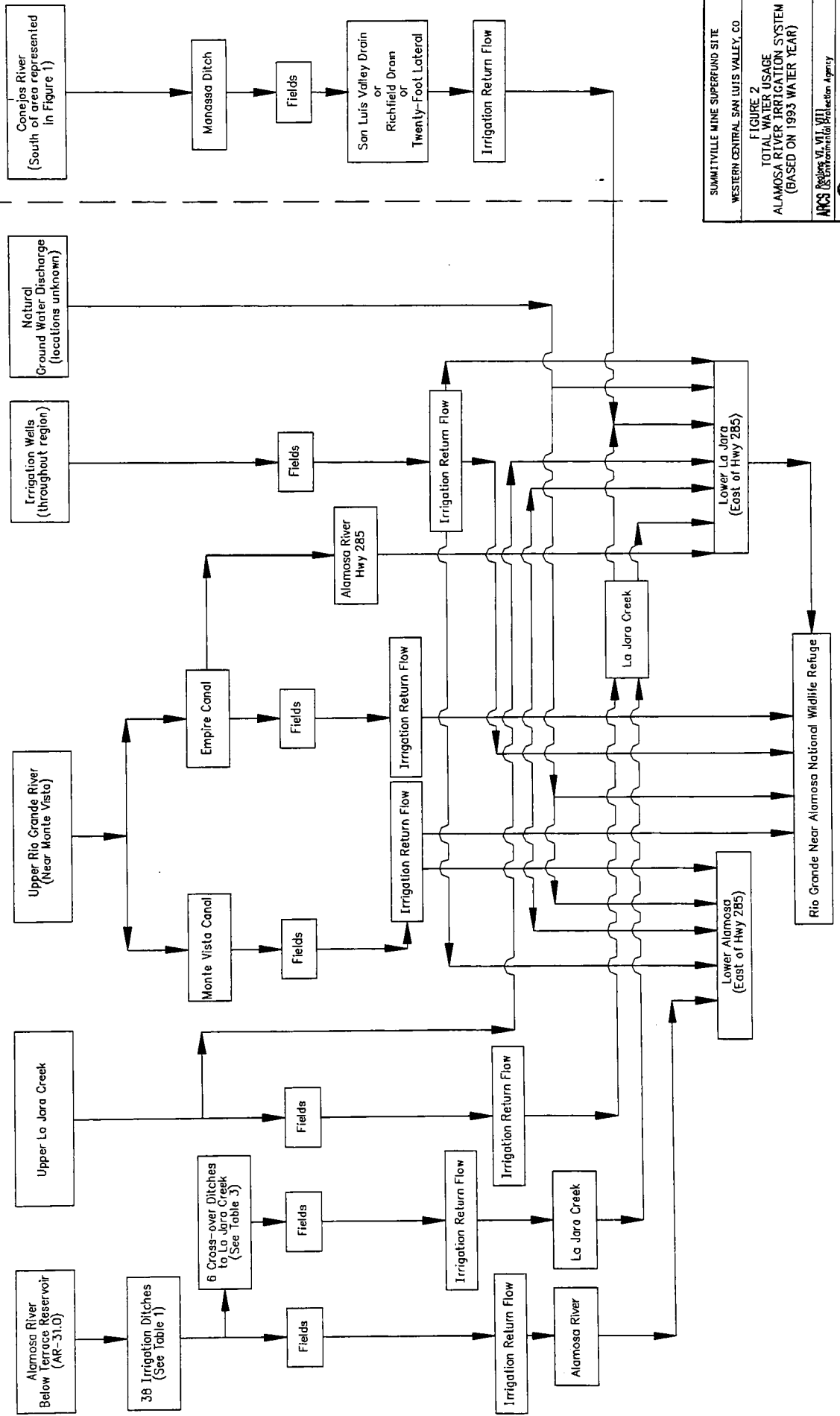

SUMMITVILLE MINE SUPERFUND SITE  
 WESTERN CENTRAL SAN LUIS VALLEY, CO

FIGURE 2  
 TOTAL WATER USAGE  
 ALAMOSA RIVER IRRIGATION SYSTEM  
 (BASED ON 1993 WATER YEAR)

APCS  
 U.S. Environmental Protection Agency

MORRISON KNUDSEN CORPORATION  
 10000 E. CENTRAL AVENUE  
 DENVER, CO 80231-1000  
 DATE: 05/23/94 (REV. 10.11.90)

DATE	BY	TYPE
05/23/94	JKS	FIGURE 2
		A

**Table 1. Alamosa River Irrigation System Diversion Information<sup>1</sup>**

Diversion Name <sup>2</sup>	Appr. Size (width x depth in feet)	Estimated Capacity (cfs)	Priority	Decreed Amount (cfs)	Location of Diversion with respect to the Alamosa River
Terrace Main Canal	6 x 3	300	2, 8, 14, 37, 39, 45, 112	331.15	North
Valdez Ditch (also called the No. 5)	3 x 1	30	9, 90	92.63	South
Davies-Chapman NA	3	30	15, 76	87.87	NA
El Viejo (also called the No. 1)	4 x 0.5	25	1	24.96	North
Alamosa Creek Canal	10 x 1	200	1, 3, 15, 71, 76, 85	216.75	North
Gabino-Gallegos 5 x 1	30	11	113	37.0	South
Madril	NA	8	89	12.45	NA
Norland	6 x 2	30 <sup>4</sup>	68	48.56	North
Miller-Alamosa	NA	100	17, 24, 70, 75	74.87	South
Romaldo Valdez	NA	5	24	6.87	North
Rivera	NA	15	88	28.80	North
San Jose No. 1	2 x 1	15	17	16.61	South
San Jose No. 2	1 x 0.5	6	14, 113A	20.58	South
Ramona	1 x 0.67	12	26	9.85	South
Garcia No. 2	2 x 0.67	7	13	5.54	South
Capulin	6 x 1.5	45	10	31.37	South
Cristobal-Revera	3 x 1	10	15	13.08	North
Ortiz	NA	20	32	14.02	NA
Scandinavian	3 x 2	45	84	43.58	North
Flintham	3 x 2	40	45, 69	27.13	North
Union	4 x 1	70	38, 62, 67, 83	455.79	North
T. K. Walsh	1 x 0.5	4	37	10.93	North
North Alamosa	NA	50	40, 74, 77	75.66	North
Morganville	3 x 2	40	73	20.75	North
Alamosa-Spring Creek 2 x 1	35	29	41, 54, 80	62.74	South
Cottonwood	3 x 1	35	44, 55, 82	35.70	North
Aroya	3 x 1	55	36	53.12	South
Clark	NA	8	58	6.75	North
Weist	NA	6	74	3.95	NA
Gallegos No. 3	NA	15	46	14.94	NA
E. Hwy 285					
Empire Canal-Alamosa	15 x 4	300	105	85.00	South
J. B. Shawcroft No. 2	NA	NA	NA	NA	North
J. B. Shawcroft No. 3	6 x 3	NA	NA	NA	North
Head Overflow No. 5	NA	155	66	49.80	North
Wade Peterson	NA	10.0	71	NA	NA
Overflow No. 1	NA	80	71	42.0	North
Lowland	NA	50	57	14.94	South
J. B. Shawcroft No. 1	6 x 3	NA	NA	NA	North

1. Diversion records from the State of Colorado Department of Natural Resources, Division of Water Resources-Division Three in Alamosa, Colorado. The records include the water years 1982 through 1993.
2. Listed in downstream order. Terrace Main Canal is the farthest west.
3. NA: Information is not available at this time.
4. Estimated capacity may have increased.

**Table 2. Alamosa River Irrigation System Diversion Summaries-Water Usage<sup>1</sup>** (Displayed by Water Year in Acre-Feet)

Diversion Name	Nov	Mar	Apr	May	June	July	Aug	Sept	Oct	Yearly Average <sup>2</sup>
W. of Hwy 285	26.4	30.1	599	1838	3321	3147	1558	660	523	11703 (33.40 cfs)
Terrace Main Canal										
Valdez Ditch	63.3	12.2	344	940	1117	733	523	387	284	4403 (11.53 cfs)
El Viejo (No. 1)	300	36	388	775	827	832	844	756	737	5307
Alamosa Creek Canal	34.9	18.6	467	1346	2076	2028	858	359	341	7528 (20.33 cfs)
Gabino Gallegos	59		155	782	922	579	367	232	196	2913
Miller-Alamosa			244	1031	1375	624	105	79.3		2925
Romaldo Valdez			16.1	80.2	92.9	47.4	15.2	1.16	0.7933	254 (1.96 cfs)
San Jose No. 1			29.2	167	184	49.5	25.8	10.8	5.32	471 (3.54 cfs)
San Jose No. 2			12.1	48.9	59.8	21.5	3.67	1.16		147 (1.47 cfs)
Ramona	9.92		105	460	468	275	100	122	243	1343
Garcia No. 2	33		74	190	191	123	72	50	72	641
Capulin	235		346	1187	1400	1145	626	189	375	4947
Cristobal-Revera	37.0		65.4	352	345	163	98.5	32.7	26.8	1120 (5.89 cfs)
Ortiz			66.7	515	535	160	40.9	24.8	27.4	1370 (9.44 cfs)
Union			65.4	1284	1133	304	27.6	17.2		2832 (25.08 cfs)
T. K. Walsh			3.95	47.3	68.0	27.7	8.10			155 (2.54 cfs)
Alamosa-Spring Creek			21.8	373	401	92.4	3.11	22.8	30.6	945 (9.74 cfs)
Aroya		1.16	92.4	1018	765	237	97.0	52.0	36.5	2300 (18.91 cfs)
Empire Canal-Alamosa River			1196	6773	9023	4214	2097	1510	3464	23079
Lowland			1249	3518	4943	793	33.7	283	432	9643
E. Hwy 285										

1. Diversion records from the State of Colorado Department of Natural Resources, Division of Water Resources Water-Division Three in Alamosa, Colorado. Records include the water years 1982 through 1993 for priorities 38 and lower.  
 2. If available, the rate of transfer in cubic feet per second (cfs) is included on the table.

**Table 3. Alamosa River Irrigation System Alamosa River-La Jara Creek Transfer Canals<sup>1</sup>**

**ACRE-FEET TRANSFERRED**

Diversion Name	Water Year (First Use Date - Last Use Date)											
	1982 <sup>2</sup>	1983	1984	1985	1986	1987	1988	1989	1990	1991	1992	1993
Valdez Ditch												
Gabino-Gallegos	-- <sup>3</sup>	? <sup>4</sup>	--	?	?	?	--	1,842 (4/9-6/23)	1,179 (5/8-6/27)	2,990 (4/25-6-11)	1,582 (5/2-6/28)	1,133 (4/25-6/9)
Miller-Alamosa	--	?	--	?	?	?	--	1,842 (4/9-6/23)	1,179 (5/8-6/27)	2,990 (4/25-6-11)	1,582 (5/2-6/28)	1,133 (4/25-6/9)
Ramona	75 (6/8-6/5)	65 (5/17-7/21)	75 (6/5-7/8)	35 (7/11-7/17)	>24 <sup>5</sup> (5/13-5/18)	139 (6/1-6/26)	24 (5/17-6/15)	107 (5/6-6/21)	121 (5/16-6/19)	67 (5/7-6/10)	43 (5/20-5/29)	57 (7/6-7/18)
Garcia No. 2	24 (7/28-7/31)	8 (7/20-7/21)	67 (6/5-6-21)	12 (7/18-7/19)	--	--	109 (6/2-6/27)	32 (6/12-6/25)	89 (5/25-6/28)	9 (6/14-6/14)	26 (5/15-6/23)	40 (6/24-6/25 & 7/14-7/19)
Capulin	115 (6/9 & 7/2-6/9)	462 (5/5-6/18)	216 (6/1-6/5 & 6/14-6/18)	40 (6/19-7/13)	--	>171 (7/9-8/7)	462 (5/7-7/20)	>521 (4/22-6/30)	>466 (4/18-6/22)	>522 (5/5-6/11)	>395 (5/16-7/26)	>216 (6/24-6/25 & 7/7-7/22)
Empire Canal- Alamosa	18,284 (5/5-9/6)	12,391 (4/28-8/12)	?	14,775 (4/8-6/13)	13,545 (5/5-6/10)	16,602 (5/4-6/30)	9,939 (5/14-7/6)	8,039 (4/19-6/26)	10,236 (5/11-7/13)	16,253 (4/19-7/18)	14,873 (4/21-7/29)	13,315 (4/26-7/20)
Lowland	1,158 (5/3-7/6)	946 (6/1-7/14)	532 (5/17-6/8)	2,112 (4/16-6/23)	776 (4/24-6/4)	778 (5/29-6/19)	91 (5/28-6/12)	67 (4/25-6/3)	137 (5/26-6/14)	917 (4/22-6/23)	691 (5/4-6/15)	1,085 (5/2-7/7)

No other noted transfers in the record for these water years between Alamosa River and La Jara Creek.

1. Diversion records from the State of Colorado Department of Natural Resources, Division of Water Resources Water-Division Three in Alamosa, Colorado. The records include the water years 1982 through 1993. Note that the Empire Canal-Alamosa and Lowland are east of Hwy 285.

2. Value displayed is the total volume of water in acre-feet that was transferred from the Alamosa River to La Jara Creek via the diversion in the noted water year, based on available records.

3. No water transfer noted for this water year.

4. Water transfer noted in records, but no volume entered.

5. Two water transfers are noted in the record, but the additional volume of water transferred was not stated in the record.

# GEOCHEMICAL DISPERSION IN SOILS ON THE ALAMOSA RIVER FLOODPLAIN, SAN LUIS VALLEY, COLORADO

By

Ronald R. Tidball, Emeritus  
U.S. Geological Survey  
Box 25046, Federal Center  
Denver, CO 80225



## INTRODUCTION<sup>1</sup>

Acid-mine drainage has been identified recently as an environmental issue in Colorado (Plumlee and others, 1993) because of the downstream impacts on fisheries, on drinking-water quality, and on agricultural uses of water for irrigation and animals. The Summitville Mine, an open-pit, cyanide heap-leach gold mine, located in the San Juan Mountains of southwest Colorado is one source of acid-mine drainage that has received considerable attention (Posey, Pendleton, and Van Zyl, 1995). The mine site was declared a Superfund cleanup site by the U.S. Environmental Protection Agency in 1994.

What is important here is that drainage from the mine enters Wightman Fork, a tributary of the Alamosa River, which then flows into the San Luis Valley and joins the Rio Grande. The San Luis Valley has a significant agricultural industry that could be adversely effected by that drainage. Because of this perceived impact on agriculture in the San Luis Valley, the Alamosa River was an important focus for this study for two reasons: (1) the river is a source of water used for irrigation and (2) soils on the Alamosa River floodplain that developed on sediments partly derived from mineralized source rocks are widely used for agriculture. Much of the sediment carried in the Alamosa River is intercepted in Terrace Reservoir, which is one of the major water sources for agricultural irrigation in the valley.

The identification of element dispersion patterns in transported sediments on alluvial fans is a common tool used in geochemical exploration to search for potential mineral deposits located upstream within a watershed. In the present study, the application of this technique was reversed to examine the extent of downstream effects from metal-laden sediments derived from a known source, such as, the Summitville Mine. The Creede Mining District located west of the study area is also an upstream source of metal-laden sediments on the Rio Grande. The downstream effects could include excessive acidity of irrigation water, elevated concentrations of dissolved metals in the water, and elevated concentrations of metals in

alluvial soils that are developed from the sediments. This report addresses the latter effect.

Nearly 1000 soil samples were collected from throughout the San Luis Valley to determine a geochemical baseline against which any sedimentation effects along the Alamosa River could be judged (Tidball and others, 1995). The present report is based on a subset of those soil samples collected only from the southwestern part of the valley, namely those collected south and west of the Rio Grande including the alluvial fans of the Alamosa River and adjacent drainages from the Conejos River on the south to the Rio Grande on the north. The purpose is to determine the magnitude and extent of dispersion of selected anomalous metals in alluvial soils and overbank sediments.

These results should be judged in their proper perspective. Basin fill materials are of course chronologic in deposition, and the near surface sampling represents comparatively recent erosional and depositional episodes. Even so those episodes could span one to several millennia, and thus could represent the cumulative effects of the following: natural erosional processes occurring during Holocene time, outwash from historical mining during the past 120 years, and outwash from the open-pit mining at Summitville Mine during the most recent decade. The sediment transport load into the valley has surely diminished since 1912 when Terrace Reservoir first began to intercept some of the sediment load of the Alamosa River.

## Acknowledgments

Numerous phases of the study including sample planning, field collections, sample processing, record keeping, and logistical support were aided immeasurably by K.C. Stewart, R.B. Tripp, and E.L. Mosier. All samples were analyzed in laboratories of the U.S. Geological Survey in Denver, Colorado, by the following individuals: ICP-AES, P.H. Briggs and D.L. Fey; S analyses; K.J. Curry and C.S. Papp; As, Se, and Hg, J.G. Crock, P.L. Hageman, D.M. Hopkins, R.J. Knight, R.M. O'Leary, K.C. Stewart, and E.P. Welsch. The aid of these individuals is material to the success of the study and is gratefully acknowledged.

<sup>1</sup> The use of trade, product, or firm names in this publication is for descriptive purposes only and does not imply endorsement by the U.S. Government.

## GEOLOGIC SETTING

The San Luis Valley is an intermontane structural depression, the northern extension of the Rio Grande Rift system (Tweto, 1979; Burroughs, 1981). The depth of basin fill material ranges from near zero on the western side of the valley to about 19,000 feet near the eastern margin (Burroughs, 1981). The San Juan volcanic field borders the entire western side of the valley and constitutes the source rock for sediments in much of the valley. Steven and Lipman (1976) identified 15 calderas in the field, and 3 more were postulated by Steven and others (1974) based on the complex stratigraphy of 18 major ash flows sheets. Of particular concern here, the Platoro caldera complex lies partly within and adjacent to the Alamosa River watershed (Lipman, 1975). The Summitville caldera is defined by Lipman as a probable late collapse of only the northwest part of the Platoro caldera. Hydrothermal alteration and mineralization developed at intersections of intrusive and extrusive centers with the marginal ring fracture structures during subsidence of the Platoro complex. Thus the possible sources of metal-rich acid waters in the watershed are multiple (Kirkham, Lovekin, and Sares, 1995). Wightman Fork, a tributary of the Alamosa River, is a major source of both solid-phase and water-extractable Cu, extractable Zn, and total As in overbank sediments (Stewart and others, 1995). Alum Creek, a tributary above Wightman Fork, was identified as a major source of Pb.

## ORE MINERALS AND ELEMENT ASSOCIATIONS

The ore deposit at Summitville Mine is a low-grade gold-silver-copper deposit developed in an epithermal acid-sulfate system (Gray and Coolbaugh, 1994). A diversity of sulfide minerals at Summitville Mine is hosted among rocks with very limited acid neutralizing capacity. During weathering of these minerals there is a potential to generate large amounts of acid drainage enriched with metals (Plumlee and others, 1995). Sulfide minerals include marcasite ( $\text{FeS}_2$ ), pyrite ( $\text{FeS}_2$ ), enargite ( $\text{Cu}_3\text{As}_4$ ), luzonite ( $\text{Cu}_3\text{AsS}_4$ ), native sulfur (S), covellite ( $\text{CuS}$ ), chalcopyrite ( $\text{CuFeS}_2$ ), tennantite ( $(\text{Cu, Fe, Zn})_{12}\text{As}_4\text{S}_{13}$ ), plus minor amounts of sphalerite ( $\text{ZnS}$ ), galena ( $\text{PbS}$ ), and the sulfate, barite ( $\text{BaSO}_4$ ).

What sort of metal dispersion could be expected from such an assemblage? Multivariate analysis based on soil

sample compositions that included 31 elements showed two significant element associations in the soils developed on Alamosa River sediments (Tidball and others, 1995): (1) As-Cu and (2) Pb-Zn. Sulfur was primarily associated with the alkaline-earth, Ca, Mg, and Sr, which are most prominent as evaporites in the northeastern part of the valley

## METHODS

Soil samples were collected in 1993 from 762 sites in the southwestern part of the San Luis Valley encompassing the Alamosa River floodplain and adjacent drainages between the Conejos River and the Rio Grande (Tidball and others, 1995). Each sample was collected from a depth of 0-12 inches (0-30 cm) using a stainless steel auger. Samples sites were located on a grid with approximately one-mile intervals. Each site was near the section corner but at least 200 feet (60 m) away from roads or farm buildings to minimize the possibility of contamination. Many sites were in cultivated fields and pastures that had been variously subjected to irrigation using either Terrace Reservoir or Rio Grande water or both.

All samples were sieved through a 2-mm stainless steel screen and the -2 mm fraction was saved. A representative subsample was ground to -100 mesh and decomposed with multiacids— $\text{HNO}_3$ ,  $\text{HClO}_4$ , and HF. The solution was analyzed for *total* concentrations of 40 elements including Cu, P, Pb, and Zn by inductively coupled plasma atomic emission spectrometry (ICP-AES) (Lichte, Golightly, and Lamothe, 1987). Total S was determined by combustion with detection by infrared absorption (IR) (Curry, 1990). Total As and Se were determined by flow injection hydride-generation-atomic absorption spectroscopy (HGAAS) (Crock and Lichte, 1982; Welsch, Crock, and Sanzolone, 1990). Total Hg was determined by continuous flow-cold vapor-atomic absorption spectrophotometry (CVAA) (O'Leary, Crock, and Kennedy, 1990). Lower limits of detection for the methods used is shown in Table 1.

Color-filled contour maps of single element distributions were created to summarize and smooth the scattered data observations using the computer software, Earthvision<sup>®</sup>, version 2.0, by Dynamic Graphics. The gridding algorithm is a minimum tension procedure. Because our interest lies in the more elevated concentrations as viewed against a background of lower values, only the 50<sup>th</sup>, 90<sup>th</sup>, 95<sup>th</sup>, and 99<sup>th</sup> percentiles of the frequency distributions are contoured.

**Table 1.—Lower limits of determination for analytical methods used in this study**

<u>Element</u>	<u>Lower limit of determination</u>	<u>Method</u> <sup>1</sup>
As, ppm	0.6	HGAAS
Cu, ppm	2	ICP-AES
Hg, ppm	.02	CVAA
P, percent	.005	ICP-AES
Pb, ppm	4	ICP-AES
S, percent	.05	IR
Se, ppm	.1	HGAAS
Zn, ppm	2	ICP-AES

<sup>1</sup> HGAAS—hydride-generation atomic spectroscopy  
 ICP-AES—inductively-coupled argon plasma-atomic emission spectroscopy  
 CVAA—cold vapor atomic absorption  
 IR—combustion/infrared detection

For purposes of this study, anomalous concentrations of an element are defined as those equal to greater than the 95<sup>th</sup> percentile of the frequency distribution for that element. Thresholds at the 95<sup>th</sup> percentile for the several elements are shown in figures 1-8, respectively.

## RESULTS AND DISCUSSION

The distribution patterns of selected metals as illustrated in figures 1-8 clearly distinguishes both the

**Table 2—Comparison of element concentration ranges and geometric means between soils of the Alamosa study area and soils of the wider San Luis Valley and the western U.S.**

<u>Element</u>	<u>Range in study area</u>	<u>Mean, soils in study area</u>	<u>Mean, soils of San Luis Valley</u> <sup>1</sup>	<u>Mean, soils of western U.S.</u> <sup>2</sup>
As, ppm	4.9-26	5.2	4.6	5.5
Cu, ppm	7-140	24	22	21
Hg, ppm	<.02-.77	<.02	--	.046
P, percent	.05-.62	.12	.11	.032
Pb, ppm	2.8-380	19	19	17
S, percent	<.05-9.4	.083	.073	.13
Se, ppm	<.1-2.9	.21	.33	--
Zn, ppm	40-590	92	86	55

<sup>1</sup> Tidball and others, 1995

<sup>2</sup> Shacklette and Boerngen,

1984

Zinc tends to occur with Pb as shown by multivariate factor analysis (Tidball and others, 1995), and this element association was found on both the Rio Grande and the Alamosa River. When viewed as a single element (Figure 3), however, Zn is anomalous (greater than 130 ppm) on the Rio

Alamosa River and the Rio Grande from among the several drainages which emerge from the San Juan volcanic field. Copper, Pb, and Zn (Figures 1-3) exhibit distinctive dispersion trains that confirm an upstream source, but different metals characterize the two rivers. Arsenic, P, S, and Se have accumulated along the lower part of the Alamosa River floodplain. A few samples containing slightly elevated concentrations of Hg and Se are also clustered on the mid part of the Alamosa River floodplain. Ranges of concentrations for several elements are compared in Table 2 with the geometric means of soils within the greater San Luis Valley and the western U.S. These means may be taken as estimates of background values.

Copper exhibits a distinctive dispersion train singular to the Alamosa River floodplain (see figure 1). Anomalous values are judged to be greater than about 47 ppm, and the maximum Cu concentration found was 140 ppm. Based on evidence found in overbank sediments for both water-extractable Cu and total Cu (Stewart and others, 1995), the principal source of the Cu is the Summitville Mine.

Lead (Figure 2) is dispersed on the floodplains of both the Rio Grande and the Alamosa River. Metal sources in the Rio Grande watershed, for example the Creede Mining District, probably represent a more significant source of Pb than anything in the Alamosa watershed. Highly anomalous samples along the Rio Grande have Pb values of 120-280 ppm whereas anomalous samples along the Alamosa have a lower range of 34-74 ppm. Most of the Pb in the Alamosa watershed appears to come primarily from the Alum Creek drainage and secondly from Wightman Fork (Stewart and others, 1995).

Grande but only slightly elevated above background (92 ppm) on the Alamosa River. Concentrations of Zn range from about 300-590 ppm on the Rio Grande floodplain and 120-140 ppm on the Alamosa floodplain.

Arsenic, P, S, and Se all exhibit accumulations near the mid part of the Alamosa River floodplain (see Figures 4-7), but any continuous dispersion train extending from the mountain front is absent. The dispersion patterns suggest that these elements have moved and accumulated in dissolved form. A model for the weathering and transport of Se as described by Presser and others (1990) in California's San Joaquin valley may well apply on the Alamosa River fan.

This model is described in terms of Se, but it could extend to other similar elements. Selenium can substitute for S in insoluble selenides resident in rocks in the Coast Range mountains. The selenide upon exposure to surface weathering becomes oxidized to the soluble selenate form, which is then carried down gradient in the shallow groundwater moving through basin-fill materials dipping toward the valley center. Dissolved salts then accumulate as evaporites near the lower extremity of the fan where the water table is close to the surface and warm, arid conditions enhance evapotranspiration.

The setting in the San Luis Valley is similar to that of the San Joaquin wherein the hydrologic gradient follows the sedimentary beds that dip downward from the western mountain front toward the valley center (Emery and others, 1971). Following such a gradient, dissolved salts have indeed accumulated as evaporites in the northeastern part of the San Luis Valley in an area of internal drainage (Edelmann and Buckles, 1984; Tidball and others, 1995). Artesian wells are common in various parts of the study area attesting to the pressure of the shallow groundwater. The climate is arid though not as warm as California. The soils are commonly alkaline, and precipitates in the soils are widespread particularly where irrigation is insufficient to leach the soils.

Arsenic tends to be associated with Cu (Tidball and others, 1995). Anomalous values are those greater than about 10 ppm. The maximum value found was 26 ppm. Arsenic could originate from any of several As-bearing minerals noted by Plumlee and others (1995) in the Summitville deposit for example. Stewart and others (1995) reported a significant increase in As and Cu in overbank sediments along the Alamosa river below Wightman Fork, which drains Summitville Mine.

Sulfur most likely occurs in floodplain soils as sulfate precipitates typically associated with alkaline-earth elements (Tidball and others, 1995). There are 30 samples with values greater than one percent and the maximum is 9.4 percent. The sulfate is transported into the valley in part in the acid waters

of the Alamosa River. Sulfate arises from the transformation through weathering of native S and sulfide minerals to sulfate from both natural sources (Miller and McHugh, 1994) and mining sources (Plumlee and others, 1993). Valley soils are normally moderately to extremely alkaline, and the presence of sulfate in the soil does little to change the pH.

Phosphorus, Se, and Hg (figure 8) are worthy of mention not so much for the anomalous concentrations found, but rather for the clustered distributions that appear to be related to the Alamosa River. The specific source of these elements is unknown, but they are assumed to be accessory elements in the volcanic centers in the watershed.

Soluble elements such as As and Se could have potential environmental impact, but only if there were circumstances that would cause significant secondary accumulation, such as, evaporation ponds or bioaccumulation by plants. Concentrations of Se found on the Alamosa River fan (1-3 ppm) compare with a maximum of only 4 ppm as found in the San Joaquin Valley (Tidball and others, 1989). In the latter case, Se concentrations were enriched in algal mats and salt crusts in evaporation ponds to 15-20 ppm, and up to 100 ppm were found in dredged sediments (Presser and Barnes, 1985). No similar concentrator is known in the San Luis Valley.

## REFERENCES CITED

- Burroughs, R.L., 1981, A summary of the geology of the San Luis Basin, Colorado-New Mexico, with emphasis on the geothermal potential for the Monte Vista graben: Colorado Geological Survey Special Publication 17, 30 p.
- Crock, J.G. and Lichte, F.E., 1982, An improved method for the determination of trace-level arsenic and antimony in geological materials by automated hydride generation-atomic absorption spectroscopy: *Analytica Chimica Acta*, v. 144, p. 223-233.
- Curry, K.J., 1990, Determination of total sulfur in geologic materials by combustion, *in* Arbogast, B.F., Quality Assurance Manual for the Branch of Geochemistry: U.S. Geological Survey Open-File Report 90-668, p. 131-135.
- Edelmann, Patrick and Buckles, D.R., 1984, Quality of groundwater in agricultural areas in the San Luis Valley, south-central Colorado:

- U.S. Geological Survey Water-Resources Investigations Report 83-4281, 37 p.
- Emery, P.A., Boettcher, A.J., Snipes, R.J., and McIntyre, H.J., Jr., 1971, Hydrology of the San Luis Valley, south-central Colorado: U.S. Geological Survey Hydrologic Investigations Atlas HA-381, 1:250,000 scale.
- Gray, J.E. and Coolbaugh, M.F., 1994, Geology and geochemistry of Summitville, Colorado: an epithermal acid-sulfate deposit in a volcanic dome, *in* Economic Geology, Special Issue on Volcanic Centers as Exploration Targets, v. 89, no. 4, p. 1906-1923.
- Kirkham, R.M., Lovekin, J.R., and Sares, M.A., 1995, Sources of acidity and heavy metals in the Alamosa River basin outside of the Summitville mining area, Colorado, *in* Posey, H.H., Pendleton, J.A., and Van Zyl, Dirk, eds., Proceedings: Summitville Forum '95, Fort Collins, Colorado, January 17-18, 1995: Colorado Geological Survey Special Publication 38, p. 42-57.
- Lichte, F.E., Golightly, D.W., and Lamothe, P.J., 1987, Inductively coupled plasma-atomic emission spectrometry, *in* Baedecker, P.A., ed., Methods for geochemical analysis: U.S. Geological Survey Bulletin 1770, p. B1-B10.
- Lipman, P.W., 1975, Evolution of the Platoro caldera complex and related volcanic rocks, southeastern San Juan Mountains, Colorado: U.S. Geological Survey Professional Paper 852, 128 p.
- Miller, W.R. and McHugh, J.B., 1994, Natural acid drainage from altered areas within and adjacent to the Upper Alamosa River Basin, Colorado: U.S. Geological Survey Open-File Report 94-144, 7 p.
- O'Leary, R.M., Crock, J.G., and Kennedy, K.R., 1990, Determination of mercury in geologic materials by continuous flow-cold vapor-atomic absorption spectrophotometry, *in* Arbogast, B.F., Quality Assurance Manual for the Branch of Geochemistry: U.S. Geological Survey Open-File Report 90-668, p. 60-67.
- Plumlee, G.S., Smith, K.S., Ficklin, W.H., Briggs, P.H., and McHugh, J.B., 1993, Empirical studies of diverse mine drainages in Colorado: implications for the prediction of mine-drainage chemistry, *in* Proceedings, 1993 Mined Land Reclamation Symposium, Billings, Montana, Volume 1, p. 176-186.
- Plumlee, G.S., Gray, J.E., Roeber, M.M., Jr., Coolbaugh, Mark, Flohr, Marta, and Whitney, Gene, 1995, The importance of geology in understanding and remediating environmental problems at Summitville, *in* Posey, H.H., Pendleton, J.A., and Van Zyl, Dirk, eds., Proceedings: Summitville Forum '95, Fort Collins, Colorado, January 17-18, 1995: Colorado Geological Survey Special Publication 38, p. 13-22.
- Posey, H.H., Pendleton, J.A., and Van Zyl, Dirk, eds., 1995, Proceedings: Summitville Forum '95, Fort Collins, Colorado, January 17-18, 1995: Colorado Geological Survey Special Publication 38, 375 p.
- Presser, T.A. and Barnes, Ivan, 1985, Dissolved constituents including selenium in waters in the vicinity of Kesterson National Wildlife Refuge and the west Grassland, Fresno and Merced Counties, California: U.S. Geological Survey Water-Resources Investigations Report 85-4220, 73 p.
- Presser, T.A., Swain, W.C., Tidball, R.R., and Severson, R.C., 1990, Geologic sources, mobilization, and transport of selenium from the California Coast Ranges to the western San Joaquin Valley: a reconnaissance study: U.S. Geological Survey Water-Resources Investigations Report 90-4070, 66 p.
- Shacklette, H.T. and Boerngen, J.G., 1984, Element concentrations in soils and other surficial materials of the conterminous United States: U.S. Geological Survey Professional Paper 1270, 105 p.
- Steven, T.A. and Lipman, P.W., 1976, Calderas of the San Juan volcanic field, southwestern Colorado: U.S. Geological Survey Professional Paper 958, 35 p.
- Steven, T.A., Lipman, P.W., Hail, W.J., Jr., Barker, Fred, and Luedke, R.G., 1974, Geologic map of the Durango quadrangle, southwestern Colorado: U.S. Geological Survey Miscellaneous Geologic Investigations Map I-764, scale 1:250,000.
- Stewart, K.C., Briggs, P.H., Fey, D.L., Malcolm, M.J., and Meier, A. L., 1995, Metal distribution in overbank sediments from the Alamosa River, south-central Colorado: U.S. Geological Survey Open-File Report 95-643, 26 p.
- Tidball, R.R., Severson, R.C., McNeal, J.M., and Wilson, S.A., 1989, Distribution of selenium, mercury, and other elements in

soils of the San Joaquin Valley and parts of the San Luis Drain Service Area, California, *in* Howard, Alice, ed., Selenium and agricultural drainage: implications for San Francisco Bay and the California environment, Proceedings of the Third Selenium Symposium, March 15, 1986: Berkeley, California, The Bay Institute of San Francisco, Tiburon, California, p. 71-82.

Tidball, R.R., Stewart, K.C., Tripp, R.B., and Mosier, E.L., 1995, Geochemical mapping of surficial materials in the San Luis Valley, Colorado, *in* Posey, H.H., Pendleton, J.A., and Van Zyl, Dirk, eds., Proceedings: Summitville Forum '95, Fort Collins, Colorado, January 17-18, 1995: Colorado Geological Survey Special Publication 38, p. 244-262.

Tweto, Ogden, 1979, The Rio Grande rift system in Colorado, *in* Riecker, R.E., ed., Rio Grande rift: tectonics and magnetism: American Geophysical Union, p. 33-56.

Welsch, E.P., Crock, J.G., and Sanzolone, R., 1990, Trace-level determination of arsenic and selenium using continuous-flow hydride generation atomic absorption spectrophotometry, *in* Arbogast, B.F., Quality Assurance Manual for the Branch of Geochemistry: U.S. Geological Survey Open-File Report 90-668, p.38-45.



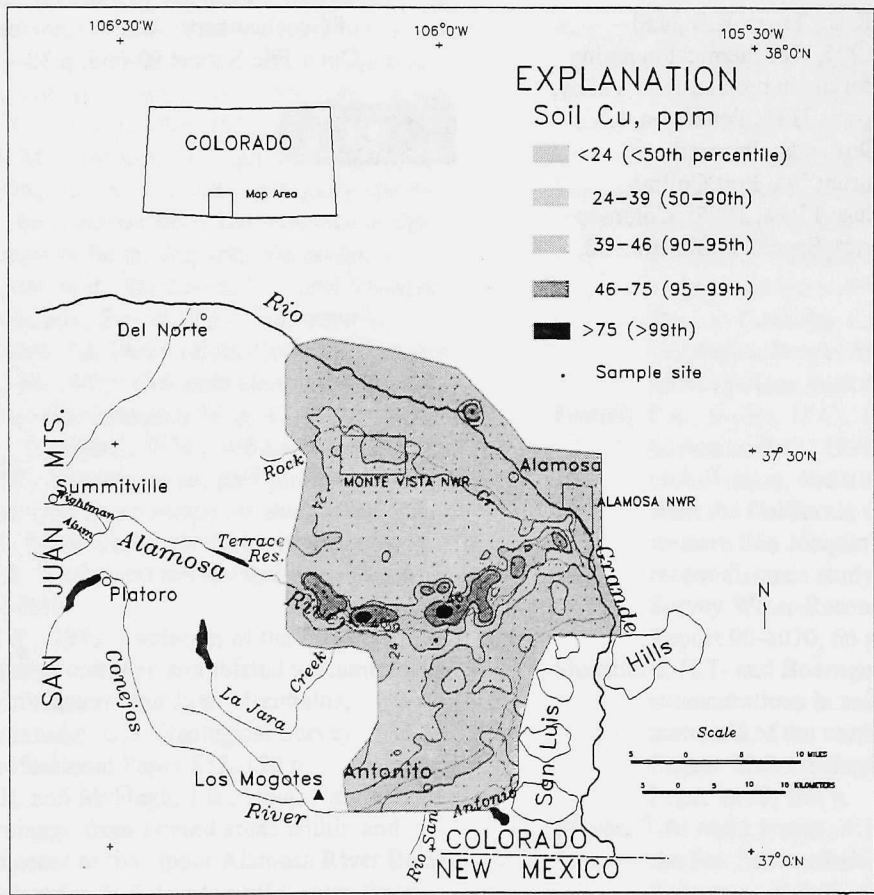

**Figure 1.—Copper in soils in the southwestern part of the San Luis Valley, Colorado. Distribution is contoured by percentiles.**

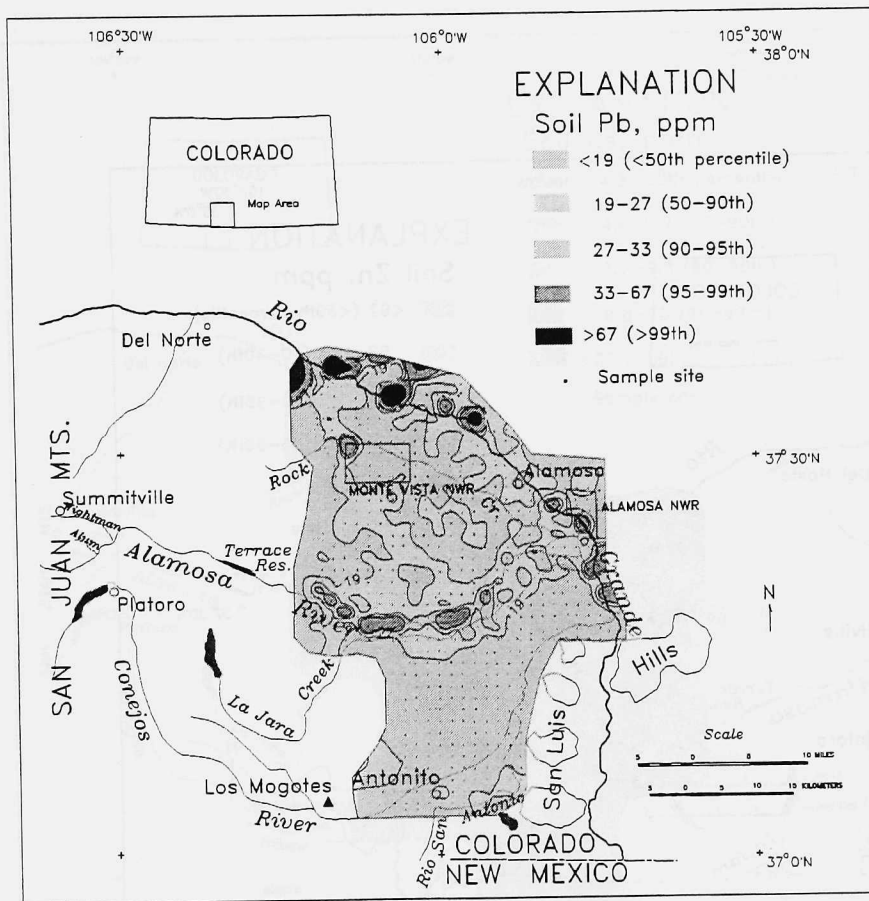

Figure 2.—Lead in soils in the southwestern part of the San Luis Valley, Colorado. Distribution is contoured by percentiles.

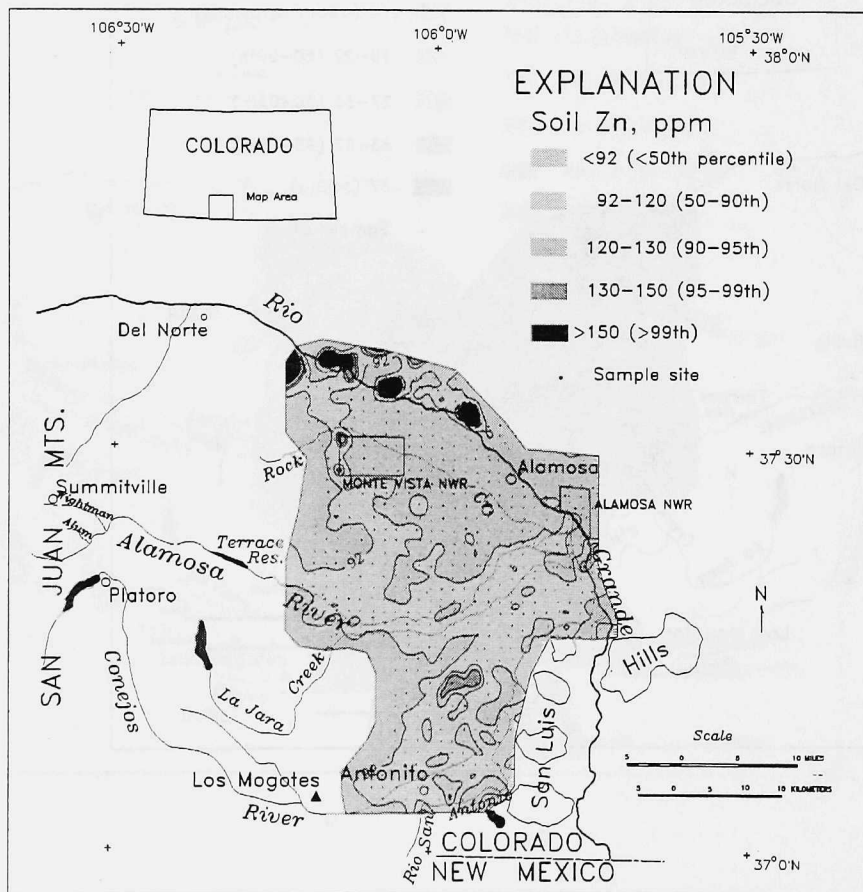

Figure 3.—Zinc in soils in the southwestern part of the San Luis Valley, Colorado. Distribution is contoured by percentiles.



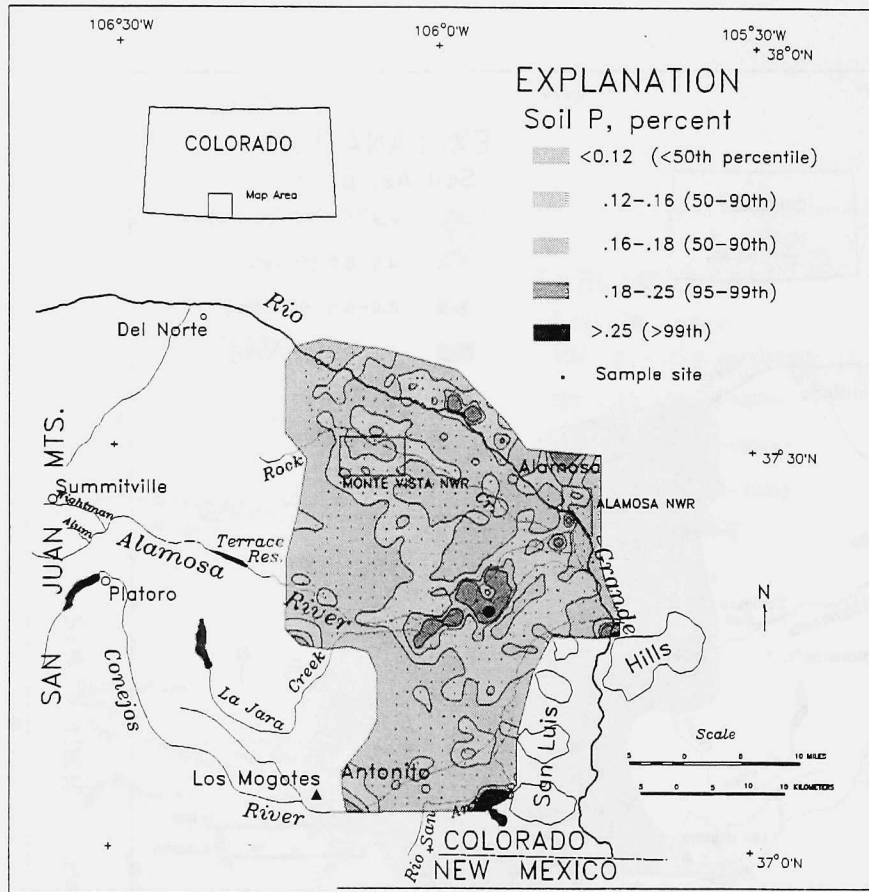

Figure 5.—Phosphorus in soils in the southwestern part of the San Luis Valley, Colorado. Distribution is contoured by percentiles.

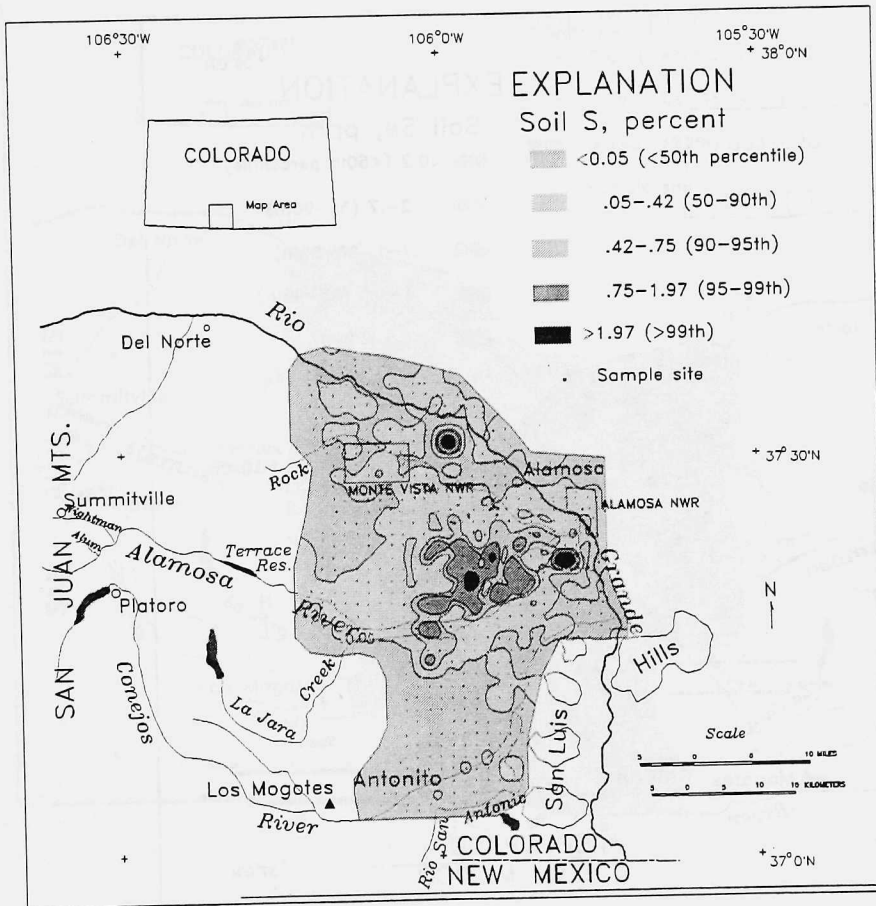

Figure 6.—Sulfur in soils in the southwestern part of the San Luis Valley, Colorado. Distribution is contoured by percentiles.

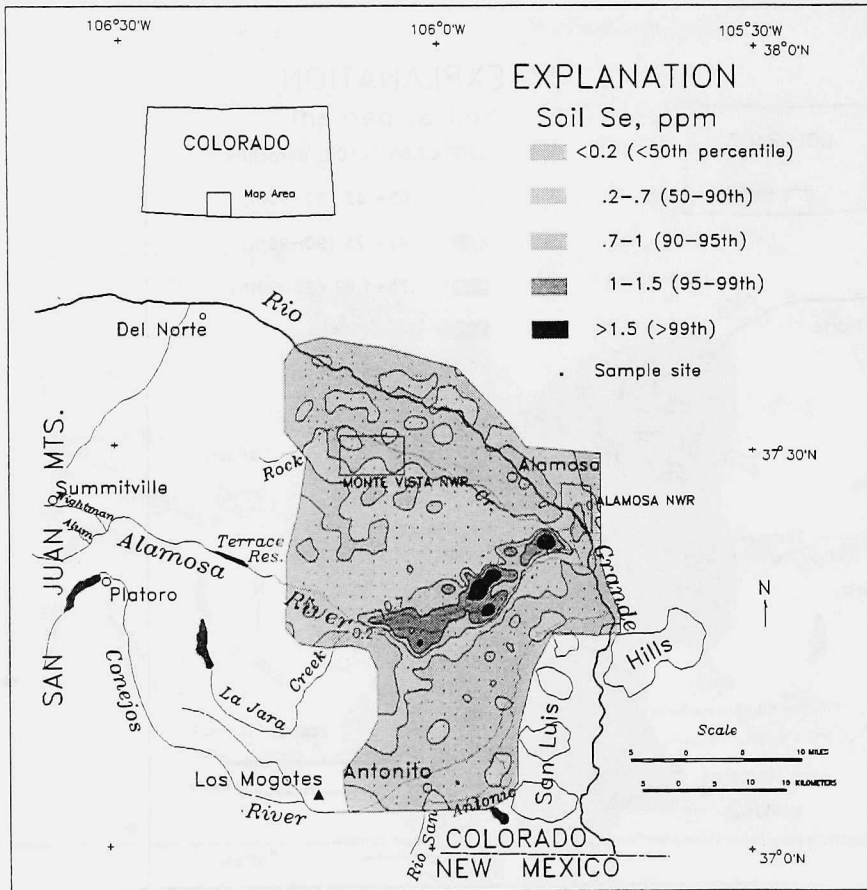

Figure 7.—Selenium in soils in the southwestern part of the San Luis Valley, Colorado. Distribution is contoured by percentiles.

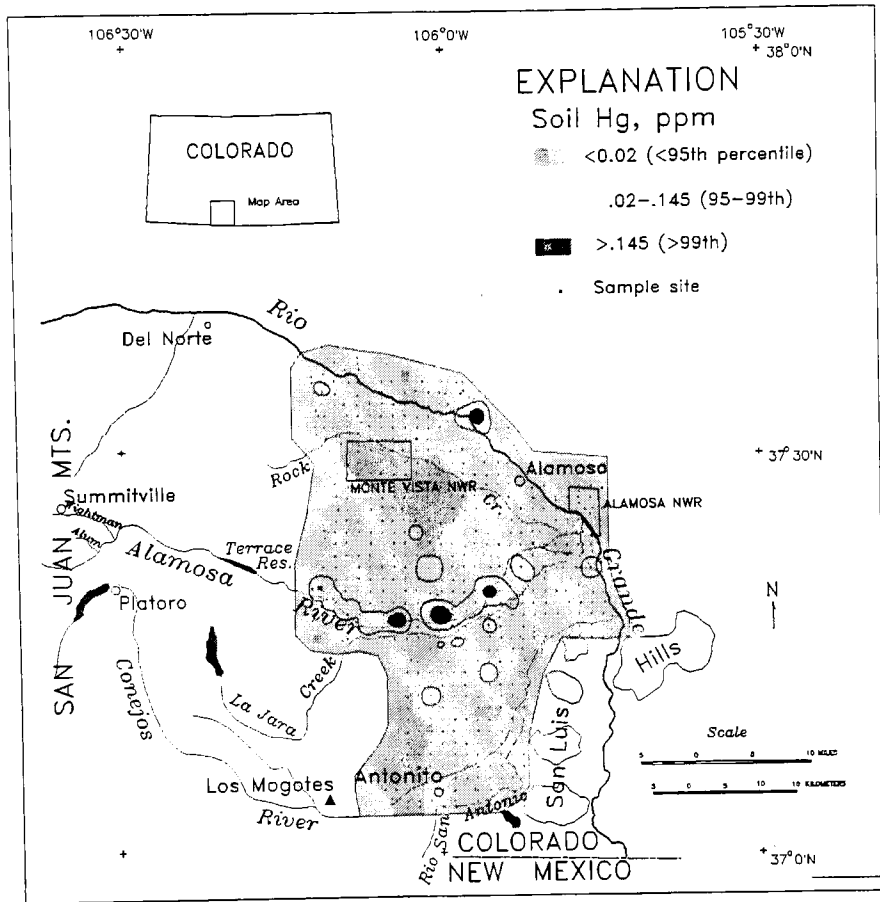

Figure 8.—Mercury in soils in the southwestern part of the San Luis Valley, Colorado. Distribution is contoured by percentiles

# MINERALOGICAL ALTERATIONS OF SOIL IRRIGATED WITH ACIDIC MINE WATER IN THE ALAMOSA RIVER BASIN

by

Stephanie J. Connolly  
Steve W. Blecker  
Grant E. Cardon  
Eugene Kelly  
Colorado State University,  
Department of Soil and Crop Sciences  
Fort Collins, Colorado 80523



## INTRODUCTION

The headwaters of the Alamosa River originate in the San Juan Mountains, a world class ore-bearing range located to the west of the San Luis Valley. The Alamosa River naturally receives large amounts of heavy metals and acidity from the watershed it drains, but it also receives the majority of the drainage from the Summitville Gold mine which introduces additional heavy metal-laden and highly acidic water. This could lead to dissolved and particulate metal loading at concentrations greater than background conditions. Downstream of the Terrace Reservoir, the pH of the Alamosa River has been reported to range from 4.2 to 7.0 with no measurable alkalinity (Erdman and Smith, 1996.) The metal loading data for the river shows high concentrations of cobalt (6-13 µg/L), copper (60-350 µg/L), zinc (150-190 µg/L), manganese (360-520 µg/L) and nickel (8-12 µg/L) (Erdman and Smith, 1996.) Smith and others (1995) concluded that there is a significant relationship between the pH of irrigation water and certain metal concentrations. As acidity increases, metal concentrations of copper, manganese and zinc increase.

In contrast, other irrigation waters such as the Rio Grande River and ground water have pH values ranging from 8.8-10.0 and very low concentrations of metals (Erdman and Smith, 1992.) It is common practice in the Alamosa River Basin, downstream of the Terrace Reservoir, to irrigate fields with Alamosa River water as well as Rio Grande River water and ground water.

The soils in the Alamosa Basin are formed over an alluvial outwash from the Platoro and Summitville calderas (Plumlee et al., 1992.) Weathering of the igneous mafic rock in the outwash results in soils which

are alkaline with high natural acid buffering capacities (Plumlee et al, 1992.) Over the past decade, the water quality of the Alamosa River has degenerated due to increased mining activity in the 1980's at the Summitville Mine (Erdman and Smith, 1996.) Since the mine closed in 1992, the mine site was declared a United States Environmental Protection Agency (USEPA) Superfund Site. A study of the mineralogy and chemical characteristics of agricultural soils of the Alamosa River Basin fills missing data gaps for the USEPA Risk Assessment Analysis of the Summitville Gold mine. The purpose of this study is to determine the mineralogical changes of the soils as a result of the addition of acidic waters to evaluate the long term buffering capacity of the soils. This paper will focus on experimental design and initial field observations from the Alamosa River Basin agricultural soils which have been subjected to a variety of water sources and irrigation practices.

## EXPERIMENTAL DESIGN

This study is divided into two phases, Phase I- the Reconnaissance Survey and Phase II- the Detailed Study. This paper will only deal with Phase I, the Reconnaissance Survey. The Phase I research work is conducted across a single soil series, the Graypoint Series of the Alamosa River Basin. The Graypoint Series, classified as a fine-loamy over sandy or sandy-skeletal, mixed, frigid Typic Haplargid, is the dominant soil series in the area (The Soil Survey Staff, 1974.) Phase I looks at six levels of management across the Graypoint series in Conejos County near Capulin, Colorado: (1) virgin soil-never irrigated nor cropped, (2) irrigated and cropped prior to but not after 1984,

(3) flood irrigated with Rio Grande river water and/or deep groundwater and cropped with alfalfa, (4) sprinkler irrigated with Rio Grande river water and/or deep groundwater and cropped with alfalfa, (5) flood irrigated with Alamosa River water and cropped with alfalfa, and (6) sprinkler irrigated with Alamosa River water and cropped with alfalfa. The study was initiated in the Spring of 1996, and the Phases I final report will be released to the public by the Colorado Department of Health and Environment December, 1996.

## SAMPLING

Six sites were chosen in August, 1995 in the Alamosa River Basin. Each site represents one of the six management schemes. Permission was obtained from local growers before entering the fields to take samples. At each field a pit was dug by backhoe. The soil profile was described using USDA Soil Survey techniques and classified according to the Keys to Soil Taxonomy (The Soil Survey Staff, 1974.) At each site an additional 4 satellite pedons were sampled, one located at each corner of the pit, 10 meters away at a 45 degree angle. The 4 satellite pedons are being used for replication for the first two horizons of the model pedon. After the description of the profile, samples were taken from each horizon for bulk soil analysis, rock identification, carbonate and oxide concretion identification, and thin section analysis. Chemical and mineralogical analyses are currently being conducted.

## SOIL PROFILE DESCRIPTIONS

### Graypoint Series

#### SITE 1

Treatment: virgin soil  
 Geomorphic position: nearly level stream terrace  
 Physiography: mountain valley (0-1% slope)  
 Elevation ~7720 ft.  
 Drainage class: well drained  
 Erosion: slight Runoff: none to slight  
 Classification: loamy- skeletal over sandy skeletal, mixed, frigid, Typic Calcic argid  
 Diagnostic horizons: 11-34 cm argillic; 34-163 cm, calcic  
 Profile facing east described in sun

**A--0 to 11 cm;** gravelly sandy loam; brown (10YR 4/3) moist; weak fine granular structure; soft, very friable, non sticky and non plastic; many fine roots throughout; no effervescence; 25% gravels, 2% cobbles; clear smooth boundary.

**Bt--11 to 34 cm;** very gravelly sandy clay loam; brown (7.5YR 4/4) moist; weak medium subangular blocky

structure; soft very friable, slightly sticky and slightly plastic; clay skins- common thin patchy on faces; many fines and few medium roots throughout; no effervescence; 45% gravels, 5% cobbles; clear wavy boundary.

**2BCk1--34 to 49 cm;** extremely gravelly sand; brown (10YR 5/3) moist; single grained; loose; non sticky and non plastic; common fine roots throughout; carbonates - none in matrix, very thin pendant coatings (1-2 mm) on clasts; slight effervescence; 65% gravels, 5% cobbles; clear wavy boundary.

**2BCk2--49 to 91 cm;** extremely gravelly sand; brown (10YR 5/3) moist; single grained; loose; non sticky and non plastic; few fine roots throughout; carbonates - none in matrix, very thin pendant coatings (1-2 mm) on clasts (slightly greater concentration than 2BCk1); slight effervescence; 60% gravels, 15% cobbles, 3% stones.

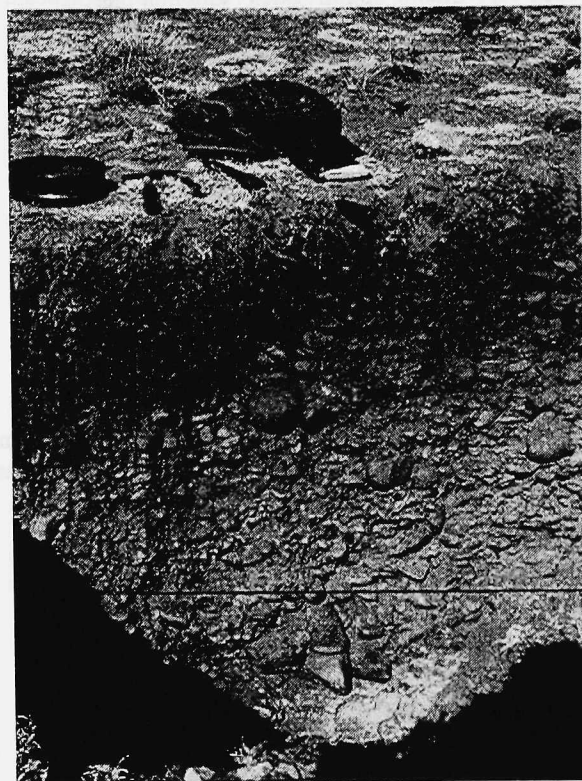

Figure 1. Site 1 - virgin soil profile.

## SITE 2

Treatment: irrigated and cropped prior to but not after 1984

Geomorphic position: nearly level stream terrace

Physiography: mountain valley (0-1% slope)

Elevation ~7750 ft.

Drainage class: well drained

Erosion: slight Runoff: none to slight

Classification: loamy- skeletal over sandy skeletal, mixed, frigid, Typic Calcicargid

Diagnostic horizons: 23-42 cm argillic; 42-81+ cm, calcic

Profile facing east described in sun

Site 5 appears to have been subjected to severe disturbance, possible erosion.

**Ap-- 0 to 23 cm;** very gravelly sandy clay loam; brown (7.5YR 4/3) moist; weak fine granular structure; soft, very friable, slightly sticky and non plastic; common fine roots throughout; no effervescence; 30% gravels; 5% cobbles; clear wavy boundary.

**Bt--23 to 42 cm;** very gravelly sandy clay loam; brown (7.5YR 4/4) moist; weak subangular blocky structure; soft, very friable, slightly sticky and non plastic; common fine and few very fine roots throughout; no effervescence; 50% gravels, 5% cobbles; clear wavy boundary.

**2Bck1--42 to 81 cm;** extremely gravelly sand; brown (7.5YR 5/4) moist; single grained; loose; non sticky and non plastic; common fine roots throughout; carbonates - none in matrix, pendant coatings on clasts; slight effervescence; 60% gravels, 25% cobbles; clear wavy boundary.

**2Bck2--81+ cm;** extremely gravelly sand; brown (7.5YR 4/2) moist; single grained; loose non sticky and non plastic; few very fine roots throughout; carbonates - none in matrix, pendant coatings on clasts (slightly greater concentration than 2Bck1); slight effervescence; 70% pebbles, 10% cobbles; gradual wavy boundary.



Figure 2. Site 2 - pre-1984 soil profile.

## SITE 3

Treatment: flood- irrigated with Rio Grande river water and/or deep ground water

Geomorphic position: nearly level stream terrace

Physiography: mountain valley (0-1% slope)

Elevation ~7675 ft.

Drainage class: well drained

Erosion: slight Runoff: none to slight

Classification: loamy- skeletal over sandy skeletal, mixed, frigid, Typic Calcicargid

Diagnostic horizons: 27-45 cm argillic; 27-87+ cm, calcic

Profile facing east described in sun

**Ap--0 to 27 cm;** gravelly heavy sandy loam; brown (10YR 4/3) moist; weak fine granular structure; soft, very friable, slightly sticky and non plastic; common fine and few coarse roots throughout; no effervescence; 15% gravels, 5% cobbles; abrupt smooth boundary.

**Btk--27 to 45 cm;** very gravelly sandy clay loam; brown (7.5YR 4/2) moist; moderate subangular blocky structure; slightly hard, very friable, slightly sticky and slightly plastic; many fine roots throughout; carbonates- disseminated, concentrated toward bottom of horizon; slight effervescence; 45% gravels, 10% cobbles; clear wavy boundary.

**Bk--45 to 60 cm;** extremely gravelly sandy loam; brown (10YR 4/3) moist; weak subangular blocky structure; slightly hard, very friable, slightly sticky and non plastic; common, very fine roots throughout; strong effervescence; 70% gravels, 5% cobbles; clear wavy boundary.

**2Bck1--60 to 87 cm;** extremely gravelly sand; brown (10YR 4/3) moist; single grained; loose; non sticky and non plastic; few coarse and few fine roots throughout; carbonates disseminated in matrix, pendant coatings on clasts; slight effervescence; 75% pebbles, 10% cobbles; gradual wavy boundary.

**2Bck2--87+ cm;** extremely gravelly sand; brown (10YR 5/3) moist; single grained; loose; non sticky and non plastic; few fine and very fine roots throughout; carbonates - pendant coatings on clasts; slight effervescence; 70% pebbles, 15% cobbles.

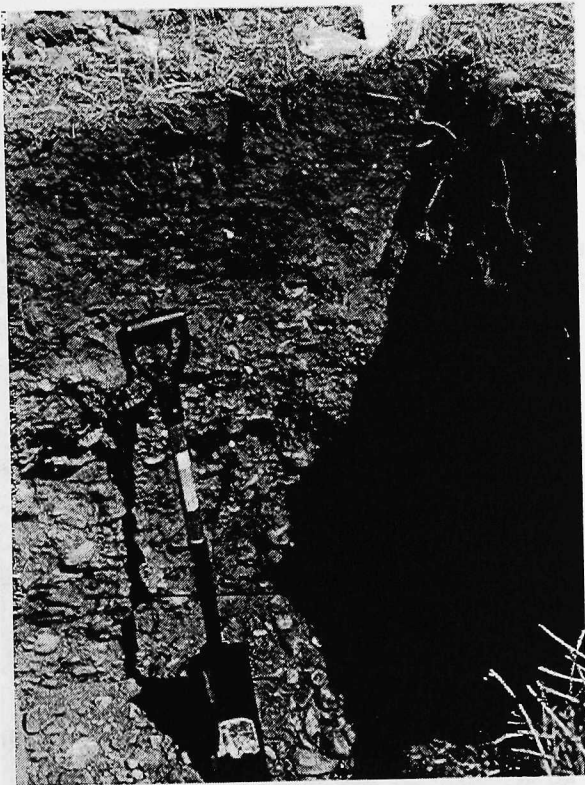

**Figure 3.** Site 3 - Rio Grande flood irrigated soil profile.

#### **SITE 4**

Treatment: sprinkler-irrigated with Rio Grande river water and/or deep ground water

Geomorphic position: nearly level stream terrace

Physiography: mountain valley (0-1% slope)

Elevation ~7675 ft.

Drainage class: well drained

Erosion: slight Runoff: none to slight

Classification: loamy- skeletal over sandy skeletal, mixed, frigid, Typic Calcigrid

Diagnostic horizons: 27-42 cm argillic; 27-104 cm, calcic

Profile facing east described in sun

**Ap--0 to 27 cm;** gravelly cobbly sandy clay loam; brown (10YR 4/3) moist; weak fine granular structure; soft, very friable, slightly sticky and non plastic; many very fine and few fine roots throughout; no effervescence; 40% gravels, 40% cobbles; clear smooth boundary.

**Btk--27 to 42 cm;** extremely cobbly sandy clay loam; brown (7.5YR 4/4) moist; weak subangular blocky structure; soft, very friable, slightly sticky and slightly plastic; few fine roots throughout; carbonates- very few soft powdery masses in matrix, many pendant coatings on clasts; strong effervescence; 40% gravels, 35% cobbles; clear wavy boundary.

**Bk1--42 to 74 cm;** extremely gravelly sandy loam; brown (7.5YR 4/4) moist; single grained; loose; non sticky and non plastic; common fine roots throughout; carbonates- very few soft powdery masses in matrix, many pendant coatings on clasts; strong effervescence; 50% gravels, 3% cobbles; clear wavy boundary.

**2Bk2--74 to 104 cm;** extremely gravelly sand; brown (7.5YR 4/4) moist; single grained; loose; non sticky and non plastic; few fine roots throughout; carbonates- very few bridging sand grains in matrix, many pendant coatings on clasts; slight effervescence; 65% pebbles, 10% cobbles; gradual wavy boundary.

**2BC--104+ cm;** extremely gravelly sand; reddish brown (5YR 4/3) moist; single grained; loose; non sticky and non plastic; few fine roots throughout; few distinct iron oxide mottles (5YR 6/6); no effervescence; 70% pebbles, 15% cobbles, 5% stones.



**Figure 4.** Site 4 - Rio Grande sprinkler irrigated soil profile.

**SITE 5**

Treatment: flood-irrigated with Alamosa River water  
 Geomorphic position: nearly level stream terrace  
 Physiography: mountain valley (0-1% slope)  
 Elevation ~7770 ft.  
 Drainage class: well drained  
 Erosion: slight Runoff: none to slight  
 Classification: loamy- skeletal over sandy skeletal,  
 mixed, frigid, Typic Torriorthent  
 Diagnostic horizons: cambic  
 Profile facing east described in sun

**Ap--0 to 28 cm;** gravelly sandy clay loam; reddish brown (5YR 4/3) moist; weak fine granular structure; slightly hard, friable, slightly sticky and slightly plastic; common very fine roots throughout; no effervescence; 25% gravels, 5% cobbles; abrupt smooth boundary.

**Bw1--28 to 57 cm;** extremely gravelly sandy loam; reddish brown (5YR 4/3) moist; single grained; loose; non sticky and non plastic; few very fine roots throughout; no effervescence; 70% gravels, 3% cobbles; clear smooth boundary.

**Bw2--57 to 79 cm;** extremely gravelly loam; yellowish red (5YR 5/6) upper half of the horizon and reddish brown (5YR 4/3) moist; single grained; soft, very friable, slightly sticky and non plastic; common medium and very fine roots throughout; no effervescence; 65 % gravels, 3% cobbles, 5% stones; clear wavy boundary.

**2Bw3--79 to 108 cm;** extremely gravelly sand; dark reddish brown (5YR 3/3) moist; single grained; loose; non sticky and non plastic; few fine roots throughout; iron and manganese staining on coarse fragments; no effervescence; 80% pebbles, 5% cobbles; gradual wavy boundary.

**2Bw4--108+ cm;** extremely gravelly sand; dark brown (7.5YR 3/2) moist; single grained; loose; non sticky and non plastic; few very fine roots throughout; very thin carbonate coatings on coarse fragments (unreactive) no effervescence; 70% pebbles, 20% cobbles.



**Figure 5.** Site 5 - Alamosa flood irrigated soil profile.

## SITE 6

Treatment: sprinkler-irrigated with Alamosa River water

Geomorphic position: nearly level stream terrace

Physiography: mountain valley (0-1% slope)

Elevation ~7770 ft.

Drainage class: well drained

Erosion: slight Runoff: none to slight

Classification: loamy- skeletal over sandy skeletal, mixed, frigid, Typic Torriorthent

Diagnostic horizons: cambic

Profile facing east described in sun

Plowing to 33 cm could have destroyed the argillic horizon, resulting in classification of the Dunul Series rather than the Graypoint Series.

**Ap--0 to 33 cm;** very gravelly sandy clay loam; brown (10YR 4/3) moist; weak fine granular structure; soft, very friable, slightly sticky and non plastic; common fine roots throughout; no effervescence; 40% gravels, 10% cobbles and 5% stones; clear smooth boundary.

**Bw1--33 to 59 cm;** very gravelly sand; dark yellowish brown (10YR 4/4) moist; weak fine subangular blocky to massive structure; loose; non sticky and non plastic; common fine roots throughout; no effervescence; 65% gravels, 10% cobbles, 2% stones; clear wavy boundary.

**2Bw2--59 to 87 cm;** extremely gravelly sand; dark grayish brown (2.5YR 4/2) moist; massive; loose; non sticky and non plastic; common fine roots throughout; very few faint carbonates (variegated), slight effervescence; 70% gravels; 15% cobbles; gradual wavy boundary.

**2Bw3--87 to 120 cm;** extremely gravelly sand; dark grayish brown (2.5YR 4/2) moist; single grained; loose; non sticky and non plastic; few very fine roots throughout; very few faint carbonates (variegated), slight effervescence; 80% gravels; 5% cobbles; gradual wavy boundary.

**2BC--120+ cm;** extremely gravelly sand; dark grayish brown (2.5YR 4/2) moist; single grained; loose; non sticky and non plastic; few very fine roots throughout; very few faint carbonates (variegated), slight effervescence; metal staining reducing zones throughout horizon; 80% gravels, 5% cobbles, 3% stones.



Figure 6. Site 6 - Alamosa sprinkler irrigated soil profile.

## DISCUSSION OF FIELD OBSERVATIONS

The degree of weathering in the Graypoint series differs according to which of the six different management schemes the soil is under. Under virgin conditions (site 1), soil formation and weathering are assumed to occur at natural rates typical of arid environments. These weathering processes have slowly developed an argillic horizon from illuviation of clay from the surface. Carbonates have accumulated on the undersides of rock clasts at and below 34 cm with increasing concentration down the soil profile. There are no carbonate concretions in the matrix. The rocks identified from this site show comparatively moderate weathering rinds and are still intact. Site 2 (irrigated and cultivated prior to but not after 1984) also has an argillic horizon and the remnants of a plowed surface horizon which has been subjected to severe disturbance and possible erosion. Carbonates are absent in the upper portion of the profile but can be found on the undersides of rock clasts at and below 42 cm as in site 1. The rocks identified from this site show larger weathering rinds than in site 1 and have some oxide staining but still are intact.

Site 3 and site 4 have greater carbonate accumulation than any of the other sites. This is likely due to the application of high pH irrigation waters moving through the soil profile. There are very few oxide stains on the rocks and weathering of the rocks is least in these two sites. Carbonates are disseminated throughout the matrix for the flood irrigated site (site 3). Under sprinkler irrigation, carbonates can be found in powdery masses within the matrix and as pendant coatings on clasts (site 4). Site 4 also shows the greatest effervescence closest to the surface presumably due to less leaching under sprinkler irrigation.

The greatest signs of weathering occur in sites 5 and 6. This is presumed to be due to the application of the acidic irrigation waters of the Alamosa River. In site 5 there is no accumulation of clay to an argillic horizon. The high water volume of flood irrigation has moved the clay out of the profile as well as leached the matrix of any reactive carbonates. The undersides of clasts found lower down in the soil profile are covered with a thin white coating that appears to be carbonate but does not react with 1 M HCl. This coating may be silica that has been leached down through the soil profile. These coatings are currently being analyzed. The rocks identified at these two sites are heavily weathered and oxide stained. Iron and manganese staining is prevalent on all rock especially gravels and cobbles. Accelerated weathering compared to control soils, has caused the rocks to breakdown upon handling of the rocks many fall apart in the hand. Significantly larger weathering rinds are present at this site than in any of the other five sites.

Site 6 is also treated with Alamosa River water but through sprinkler irrigation. The lower volume application of acidic irrigation water under sprinklers has left thin coatings of carbonates on the undersides of clasts described as variegated in the soil profile description. As in site 5, site 6 does not have enough clay accumulation to have an argillic horizon. Also in the 2BC horizon rocks are heavily stained with iron and manganese oxides.

It is our observation that the use of Alamosa River water for irrigation has considerably altered the degree of weathering in the soils of the Alamosa River Basin. This is evident in the lack of carbonates in the profile when compared to soils irrigated with other sources of water, the increased iron and manganese staining on rocks, and the increased degradation of the rocks.

Other than field observations very few conclusions can be made at this time. Extensive chemical and physical analyses of the samples from each sites is being conducted in cooperation with Colorado School of Mines and Agro-Engineering of Alamosa, Colorado. Experiments are being conducted to determine the present state of the soils in the Alamosa River Basin

and to predict the long-term acid buffering capacity of the soils. Modeling will be used to determine the annual acid and heavy metal loading that these soils will be able to withstand without further degradation. Finally, the study will help local agriculturists make better decisions on how to manage their fields when irrigating with Alamosa River water.

## REFERENCES

- Erdman, James A. and K. S. Smith. 1996. Impact of Alamosa River Water on Alfalfa Southwestern San Luis Valley, Colorado. U.S. Department of the Interior U.S. Geological Survey, Denver, Colorado. Open file report 96-034. U.S. Gov. Print. Office Washington. DC.
- Plumlee, Geoffrey S., J.E. Gray, M. Roeber, Jr., M. Coolbaugh, M. Flohr, and G. Whitney. Importance of Geology in Understanding and Remediating Environmental Problems at Summitville, in Posey, H.H., Pendleton, J.A., and VanZyl, Dirk, eds., Proceedings Summitville Forum '95: Colorado Geological Survey Special Publication 38, 13-22.
- Smith, K.S., E.L. Moiser, M.R. Montour, G.S. Plumlee, W.H. Ficklin, P.H. Briggs, and A.L. Meier. 1995. Yearly and seasonal variations in acidity of metal content of irrigation waters from the Alamosa River, Colorado, in Posey, H.H., Pendleton, J.A., and VanZyl, Dirk, eds., Proceedings Summitville Forum '95: Colorado Geological Survey Special Publication 38, 293-298.
- Soil Survey Staff. 1974. Conejos County, Colorado Soil Survey Report. USDA-SCS. U.S. Gov. Print. Office, Washington, DC.
- Soil Survey Staff. 1975. Soil taxonomy: a basic system of soil classification for making and interpreting soil surveys. USDA-SCS Agric. Handb. 436. U.S. Gov. Print. Office, Washington, DC.



# STREAM CONTAMINATION FROM THE SUMMITVILLE MINE AND ITS IMPACT ON ALFALFA PRODUCTION IN PART OF THE SAN LUIS VALLEY

James A. Erdman and Kathleen S. Smith  
U.S. Geological Survey, Mailstop 973, Denver Federal Center, Denver, Colorado 80225



## INTRODUCTION

Agriculture underpins the economy of the San Luis Valley and the livelihoods of many of those who live there. Copper levels in alfalfa have been the main focus in a 3-year study (1993–1995) of fields irrigated from the lower Alamosa River and Terrace Reservoir.

Recent open-pit mining and the abandonment of the Summitville gold mine in the San Juan Mountains in late 1992 have led to serious problems with acid-mine drainage (Environmental Protection Agency, 1993). Contamination from the high-sulfidation epithermal gold mine (Plumlee and others, 1995a, b) has raised concerns over the effects of low pH and metal-laden—particularly copper—surface waters carried down the Alamosa River. High sulfidation deposits commonly contain copper-arsenic minerals, especially easily weathered sulfosalts (Stoffregen, 1987). Estimated copper loadings from the main drainage adit (now plugged) at the mine site into the Wightman Fork of the Alamosa River were 143,000 pounds per year (Williams, 1995). Previous studies of water quality of the Alamosa River and Wightman Fork showed that the Summitville site

on Wightman Fork has been the predominant source of aluminum, copper, iron, manganese, and zinc discharged into the Alamosa River during most of the year (Walton-Day and others, 1995; Mueller and Mueller, 1995). Water-quality data collected by the U.S. Geological Survey during 1995 indicate that Wightman Fork was the dominant source of copper and manganese that year (USGS/WRD, Pueblo, Pat Edelmann, written commun., 1996). These waters enter the Terrace Reservoir (fig. 1), which stores irrigation water for approximately 45,000 acres of farmland downstream in the southwestern part of the San Luis Valley (Environmental Protection Agency, 1993).

Following the abandonment of the mine, which drew the focus of extensive public attention, numerous studies were begun at the mine site and downstream at Terrace Reservoir and in the San Luis Valley. Many of the results were discussed and published at a forum on Summitville in early 1995 (Posey and others, 1995). Summitville is the first of the modern, heap-leach gold mines to be abandoned and require cleanup under the EPA's Superfund program (Williams, 1995).

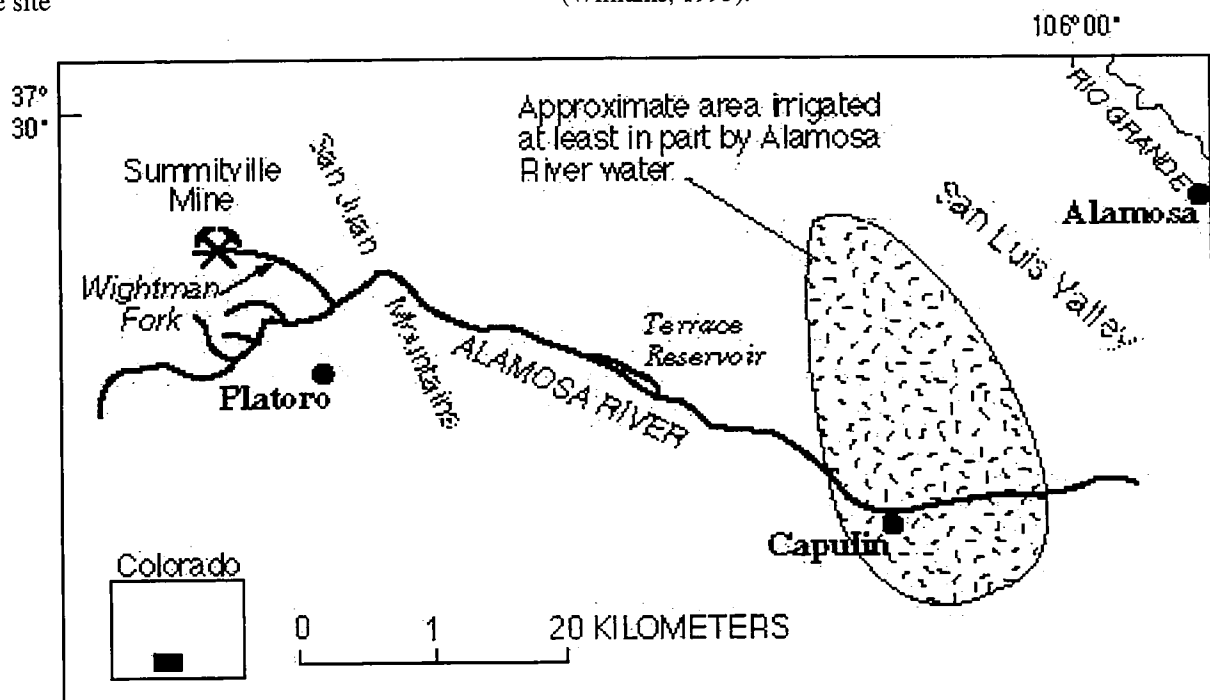

Figure 1. Index map showing location of Summitville mine and Terrace Reservoir with respect to farmlands irrigated with water from the reservoir.

Negative publicity resulting from contamination of Alamosa River water irrigating even a small part of the valley might have had a ripple effect throughout the region. However, this possibility was averted through a brief report and accompanying press release shortly after the 1993 alfalfa results became available (Erdman and Smith, 1993).

## METHODS

Three alfalfa fields irrigated by water from the Terrace Reservoir and sampled in June 1993 were resampled in July 1995 using an analysis-of-variance design. Alfalfa from the Terrace-irrigated fields was compared with three control fields that were irrigated from the Rio Grande or ground water. Alfalfa samples were collected prior to each of the three cuttings in 1994 from two fields irrigated by Terrace water, but no control fields were sampled.

Soils from all fields are either mapped as the same soil series or are physically similar. Water samples were collected from the center-pivot sprinkler-irrigated fields to evaluate differences between the Terrace water and the control water. We also tested possible changes between 1993 and 1995.

Field and analytical techniques are detailed in Erdman and others (1995a, 1996).

## RESULTS

An initial study of the effects of Summitville on alfalfa was conducted in June 1993. Those results, based on alfalfa sampled from Terrace-irrigated fields and control fields, were reported by Erdman and others (1995a). Analysis-of-variance showed significantly higher concentrations of copper, manganese, and nickel in alfalfa from the affected fields. More importantly, concentrations of these metals in alfalfa affected by both water sources (i) met published nutritive requirements for cattle, (ii) were far below maximum tolerable levels reported for cattle, and (iii) were comparable to concentrations in alfalfa found in other parts of the country. In looking at the nutritional needs of *alfalfa*, Erdman and others (1995a) found that the Terrace Reservoir waters seemed to have enhanced the bioavailability of copper and manganese to optimum levels.

In the 1994 irrigation season, unexpectedly large seasonal differences in pH and the concentrations of copper and manganese (figs. 2 and 3) occurred in water from the Alamosa River (Smith and others, 1995). These figures also show the strong relationship between acidity and metal levels. Between early June and late July 1994, acidity increased 100-fold, from a nearly neutral pH of 6.6 down to 4.7. In the same period, copper concentrations increased sevenfold, manganese doubled, and zinc tripled. The profound chemical changes in the irrigation water between the first and second cuttings were not anticipated.

Fortunately, plans were already in place to sample the three cuttings of alfalfa from two adjacent fields irrigated by Terrace Reservoir water throughout the growing season. The alfalfa sampled from two adjacent fields reflected the changes in water chemistry (figs. 4 and 5), but not to the same degree (Erdman and others, 1995b).

The 1995 study of alfalfa and associated irrigation water was conducted to test whether water from the Terrace Reservoir still affected the quality of alfalfa to an important degree. An added purpose was to compare these results with previous studies conducted in 1993 and 1994.

In July 1995, the pH in the irrigation water below Terrace Reservoir, at 5.5, was comparable to that measured in 1993 (figs. 2 and 3). Concentrations of copper and manganese—two metals linked closely to contamination from the Summitville mine Superfund site—were also similar to those measured from the same irrigation water in 1993. In addition to copper and manganese, concentrations of zinc, cobalt, nickel, and the rare-earth elements lanthanum, cerium, neodymium, and yttrium were markedly higher in the Terrace waters compared to the control waters.

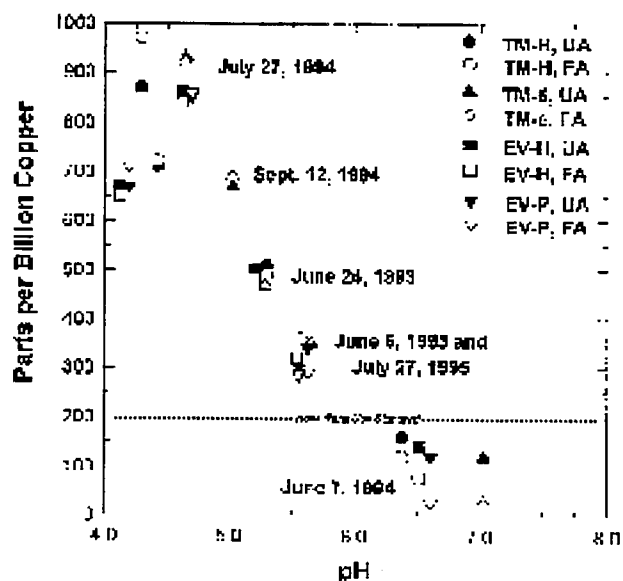

**Figure 2. Plot of copper concentration as a function of pH for irrigation water originating from Terrace Reservoir for the period from June 1993 to July 1995. TM-H is the Terrace Main Canal headgate on the Alamosa River, TM-S is a site on the Terrace Main Canal approximately 15 km from the headgate, EV-H is the El Viejo Ditch headgate on the Alamosa River, and EV-P is a storage pond on the El Viejo Ditch approximately 7 km from the headgate. UA refers to unfiltered acidified water samples and FA refers to filtered (0.45  $\mu\text{m}$  in 1993 and 1995, and 0.2  $\mu\text{m}$  in 1994) acidified water samples.**

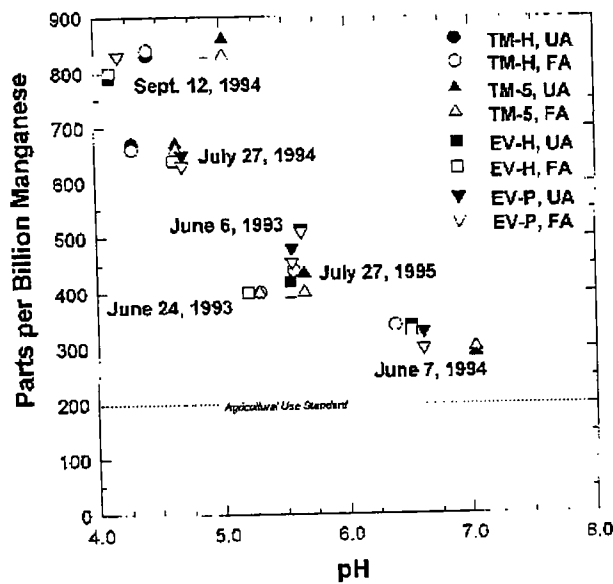

Figure 3. Plot of manganese concentration as a function of pH for irrigation water originating from Terrace Reservoir for the period from June 1993 to July 1995. See figure 2 for explanation of sources.

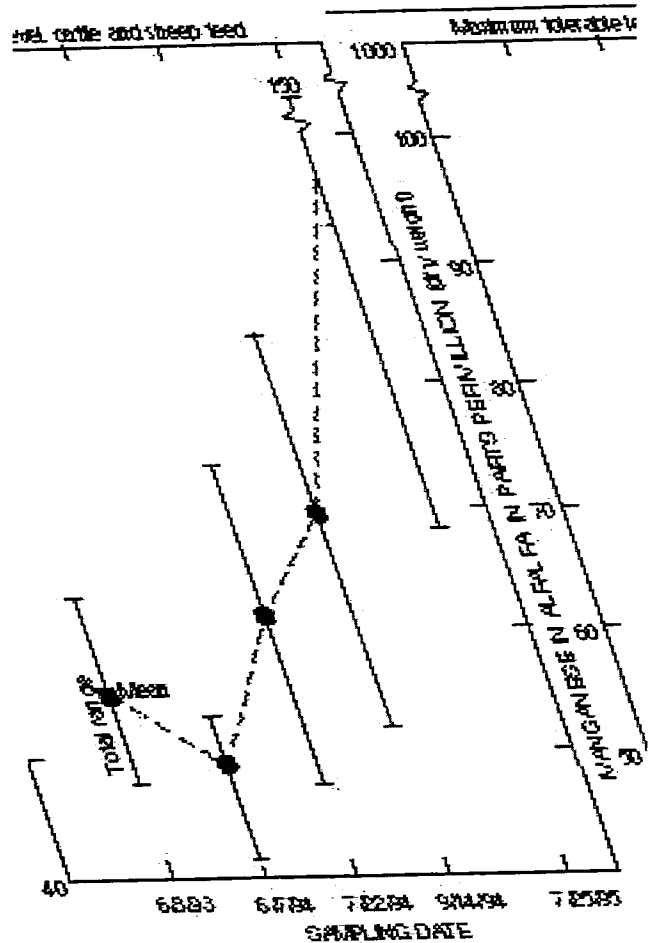

Figure 5. Plot of manganese levels in alfalfa irrigated with Terrace Reservoir water over the 1993 through 1995 period.

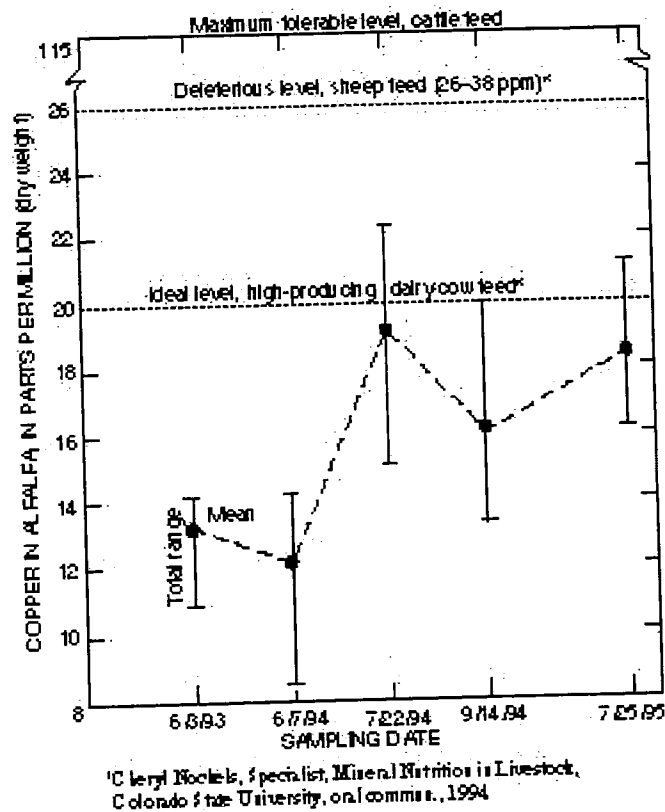

Figure 4. Plot of copper levels in alfalfa irrigated with Terrace Reservoir water over the 1993 through 1995 period.

Only levels of copper and manganese in the contaminated water have exceeded the agricultural use standards for Colorado, although concentrations of several other metals also far exceed those of samples from the control waters.

A two-way analysis-of-variance tested, separately, the year-to-year (temporal) differences in the element composition of the test group alfalfa and the control group. The test-group samples had significantly higher concentrations of copper and manganese in the June 1995 cuttings compared to the June 1993 cuttings (figs. 4 and 5). The test-group samples also contained significantly higher concentrations of cobalt, nickel, and phosphorus. Unexpectedly, however, the control-group alfalfa also revealed significantly higher concentrations for almost the same suite of metals—copper, manganese, nickel, phosphorus, and zinc—in samples from the 1995 cutting. Although the average concentrations were lower than those samples irrigated by Terrace water, these results underscore the complexity of trying to understand relationships in the natural landscape.

Cleryl Noels, Specialist, Mineral Nutrition in Livestock, Colorado State University, oral comm., 1994

The maximum copper concentration measured—21 ppm—is considered nutritionally ideal for high-production dairy ration. On the other hand, this level approached the lower end of the 26–38 ppm range considered deleterious for sheep feed (Dr. Cheryl Nockels, Colorado State University, oral commun., December 1995). The published maximum tolerance level for beef cattle is 115 ppm. Sheep are therefore much less tolerant of copper than cattle, although the copper tolerance varies with breed.

The manganese concentrations in alfalfa have increased markedly over the 3-year period (fig. 5). In the short term, this should not affect the nutritional value of this important livestock feed. The highest concentration reported, 150 ppm, is still well below the 1,000 ppm maximum tolerable level given for cattle and sheep. However, this exceeds the upper limit of the sufficient manganese requirement range for *alfalfa* (Jones and others, 1991).

Many irrigators who rely on Alamosa River water continue to be concerned about the marketability of their crops and livestock. Unlike the copper concentrations that appear to have leveled off, manganese concentrations have continued to climb beyond those reported in alfalfa grown in other parts of the West.

### PITFALLS IN RELYING ON SINGLE POINT-IN-TIME STUDIES

Unlike the initial results from 1993, no statistically significant differences were found in 1995 for copper in alfalfa irrigated by the two water sources, in large measure because concentrations of several metals—copper, zinc, and barium—were appreciably higher in alfalfa collected from one of the three control fields. Yet concentrations of manganese in alfalfa from the two affected fields were twice the concentrations in the samples from the control fields, differences that were statistically significant (90% confidence level). Of 15 elements tested, only the concentrations of one other element—cobalt—were statistically different, but alfalfa from the affected fields contained only slightly higher concentrations of the 13 other elements tested than did the control samples. On average, the copper concentrations in alfalfa irrigated by the two different water sources were nearly the same.

Even though the nutritional quality of alfalfa as a livestock feed has not been impaired—in fact, the copper levels in the affected alfalfa are considered nutritionally ideal for high-production dairy ration—these temporal swings emphasize the critical importance of long-term monitoring. Results from this repeat sampling of alfalfa suggest that baselines which ignore the vagaries of time may be misleading.

## REFERENCES

- Environmental Protection Agency, 1993, Summitville mining site "Backgrounder." Factsheet, January 1993.
- Erdman, J.A., and Smith, K.S., 1993, Impact of the Summitville Mine on irrigation water, agricultural soils, and alfalfa in the southwestern San Luis Valley, Colorado: U.S. Geol. Survey Open-File Report 93–616, 4 p.
- Erdman, J.A., Smith, K.S., Dillon, M.A., and ter Kuile, Maya, 1995a, Impact of Alamosa River water on alfalfa, southwestern San Luis Valley, Colorado: *in* Posey, H.H., Pendleton, J.A., and Van Zyl, Dirk, eds., Proceedings Summitville Forum '95: Colo. Geol. Survey Spec. Publ. 38, p. 263–271.
- Erdman, J.A., Smith, K.S., and ter Kuile, Maya, 1995b, Impact of the lower Alamosa River water on alfalfa, southwestern San Luis Valley, Colorado—1994 follow-up study: U.S. Geol. Survey Open-File Report 95–43, 13 p.
- \_\_\_\_\_, 1996, Impact of the lower Alamosa River water on alfalfa, southwestern San Luis Valley, Colorado—1995 follow-up study of effects from the Summitville Mine: U.S. Geol. Survey Open-File Report 96–034, 32 p.
- Jones, J.B., Jr., Wolf, Benjamin, and Mills, H.A., 1991, Plant analysis handbook, Athens, Georgia, Micro-Macro Publishing, Inc.
- Mueller, Mary, and Mueller, T.A., 1995, Events and trends monitoring of water quality on the Alamosa River and selected tributaries—1994, *in* Posey, H.H., Pendleton, J.A., and Van Zyl, Dirk, eds., Proceedings Summitville Forum '95: Colo. Geol. Survey Spec. Publ. 38, p. 215.
- Plumlee, G.S., Gray, J.E., Roeber, M.M., Jr., Coolbaugh, M.E., Flohr, M., and Whitney, C.G., 1995a, The importance of geology in understanding and remediating environmental problems at Summitville, *in* Posey, H.H., Pendleton, J.A., and Van Zyl, Dirk, eds., Proceedings Summitville Forum '95: Colo. Geol. Survey Spec. Publ. 38, p. 13–22.
- Plumlee, G.S., Smith, K.S., Mosier, E.L., Ficklin, W.H., Montour, M.R., Briggs, P.H., and Meier, A.L., 1995b, Geochemical processes controlling acid-drainage generation and cyanide degradation at Summitville, *in* Posey, H.H., Pendleton, J.A., and Van Zyl, Dirk, eds., Proceedings Summitville Forum '95: Colo. Geol. Survey Spec. Publ. 38, p. 23–34.
- Posey, H.H., Pendleton, J.A., and Van Zyl, Dirk, eds., 1995, Proceedings Summitville Forum '95: Colo. Geol. Survey Spec. Publ. 38, 375 p.

- Smith, K.S., Mosier, E.L., Montour, M.R., Plumlee, G.S., Ficklin, W.H., Briggs, P.H., and Meier, A.L., 1995, Yearly and seasonal variations in acidity and metal content of irrigation waters from the Alamosa River, Colorado, *in* Posey, H.H., Pendleton, J.A., and Van Zyl, Dirk, eds., Proceedings Summitville Forum '95: Colo. Geol. Survey Spec. Publ. 38, p. 293–298.
- Stoffregen, R., 1987, Genesis of acid sulfate alteration and Au-Cu mineralization at Summitville: *Econ. Geology*, vol. 82, p. 1575–1591.
- Walton-Day, Katherine, Ortiz, R.F., and von Guerard, P.B., 1995, Sources of water having low pH and elevated metal concentrations in the upper Alamosa River from the headwaters to the outlet of Terrace Reservoir, south-central Colorado, April-September, 1993, *in* Posey, H.H., Pendleton, J.A., and Van Zyl, Dirk, eds., Proceedings Summitville Forum '95: Colo. Geol. Survey Spec. Publ. 38, p. 160–171.
- Williams, L.O., 1995, Is Summitville really unique?, *in* Posey, H.H., Pendleton, J.A., and Van Zyl, Dirk, eds., Proceedings Summitville Forum '95: Colo. Geol. Survey Spec. Publ. 38, p. 362–368.



# THE BIOGEOCHEMISTRY OF WETLAND ECOSYSTEMS AND TREE RINGS IN THE SAN LUIS VALLEY, COLORADO—THE EFFECT OF NATURAL AND HUMAN-INDUCED METAL-RICH, ACID DRAINAGE

By

L.P. Gough, L.S. Balistrieri, F.E. Lichte, T.M. Yanosky, and R.C. Severson  
U.S. Geological Survey

Andrew Archuleta  
U.S. Fish and Wildlife Service



## INTRODUCTION

The Summitville Mine, located near the old mining town of Summitville in Rio Grande County, Colorado, operated between July 1986 and December 1992 as a large-tonnage open-pit heap-leach gold mine. During its 6 years of existence the trace metal levels in drainage water from the mine site were elevated over historical (pre-1986) levels (Moran and Wentz, 1974) due to input from three sources—heap leach water, seeps that occur throughout the mine workings, and an increase in the metal load of water coming from the old Reynolds Adit. Mine-drainage waters flow into Wightman Fork, a small tributary of the Alamosa River, which in turn flows east into the San Luis Valley. The increase in the trace metal burden of the Alamosa River watershed is of concern to farmers, land owners, and Federal and State wildlife agencies.

The information presented here is largely abstracted from reports previously published (Balistrieri and others, 1995; Gough and others, 1995).

## PURPOSE AND OBJECTIVES

This study seeks to chart potential spatial and temporal trace metal trends in drainage water chemistry through the analysis of metal levels in individual tree rings from narrow-leaf cottonwood (*Populus angustifolia* James) and, to a lesser extent, quaking aspen (*Populus tremuloides* Michx.). As stated below, the use of tree ring chemistry in the characterization of contaminated sites is a viable technique and its use in this regional study has promise.

Also, this study assesses the impact of acid drainage on selected wetlands in the San Luis Valley. We compared the biogeochemistry of wetlands that receive surface water from the Alamosa River with wetlands that receive surface water from sources that carry little or no drainage from mineralized areas (e.g., Rio Grande River). We collected and analyzed water and stream-bed sediment from the Wightman Fork and Alamosa River to identify elements that are indicative of drainage from mineralized areas (i.e., indicator or tracer elements) and to assess the extent of their transport throughout the Alamosa River system. We also collected and analyzed

water, sediment, and rooted aquatic vegetation from wetlands that receive surface water

from several sources—Alamosa River, La Jara Creek, and Rio Grande River—particularly those located in the Alamosa National Wildlife Refuge.

The wetlands are seasonal hosts to migratory birds such as the endangered whooping crane, and the U.S. Fish and Wildlife Service is concerned about the possible impact of metal-enriched drainage on the stability, productivity, and quality of these wetland ecosystems.

## METHODS

The field studies were conducted between June 24–29, 1993. Details of field and laboratory methods are published (Balistrieri and others, 1995; and Gough and others, 1995) and are only summarized here.

### Tree-ring samples

Samples of aspen were collected from riparian, mixed coniferous forest communities along the Wightman Fork and the Alamosa River from just above the confluence to just below (Sites B, C, and D, fig. 1). Samples of narrowleaf cottonwood were collected from the same communities along the Alamosa River at Sites E, F, G, H, I, J, and K. These sites were spaced about 5 kilometers apart from just below the confluence of the Alamosa River with the Wightman Fork to a point down river about 50 kilometers (fig. 1). Aspen was collected at Sites B–D because Site E was the elevational upper-most extent of cottonwood. The last four sites (H, I, J, and K) were located within the San Luis Valley.

Samples consisted of cores of xylem material collected at 1.5 m above the ground. At each site cores were extracted from each of two adjacent mature trees. From one of the two trees a second core was extracted immediately parallel to the first one as a within-tree replicate sample.

### River samples

Stream-bed sediment and water were collected from the Wightman Fork and 10 locations along the Alamosa

River; the same localities as were sampled for tree-ring cores (fig. 1).

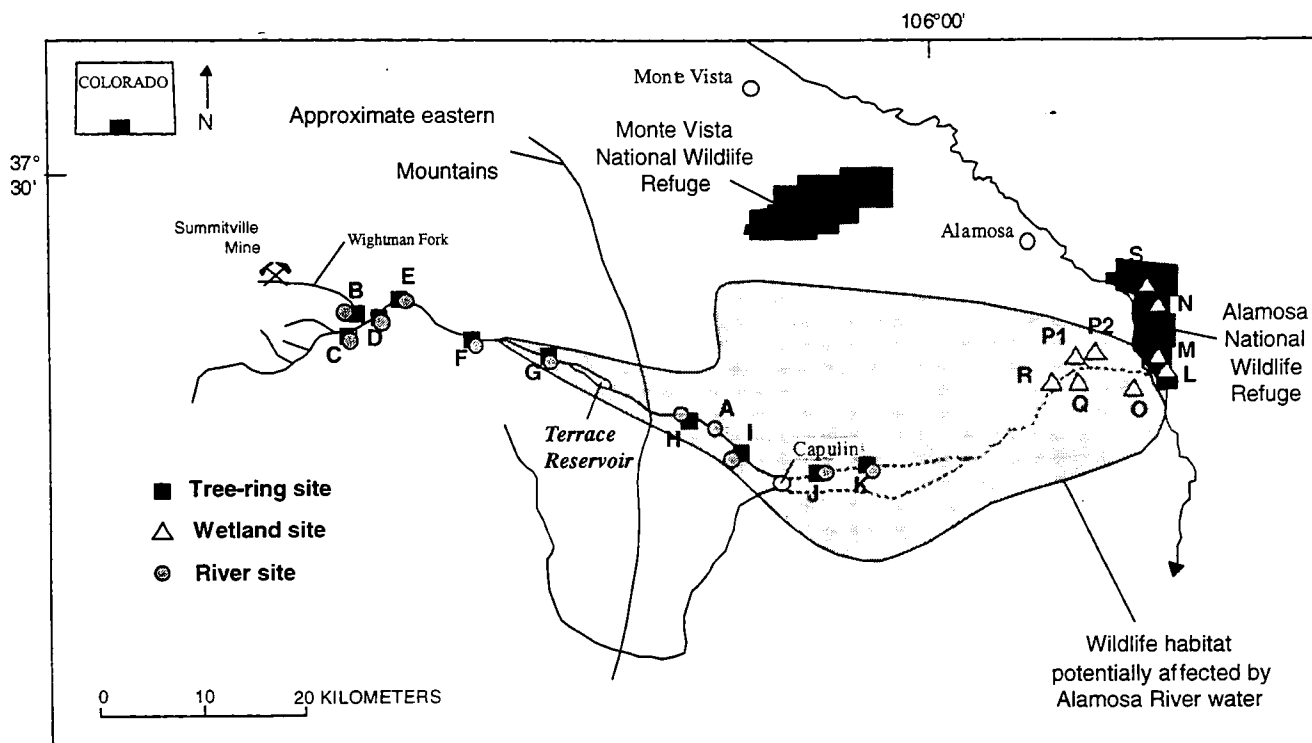

Figure 1. Map showing sampling sites for tree-rings, sediments, and water (Wightman Fork and upper Alamosa River), and wetland water, sediment, and aquatic plants (lower Alamosa River and Alamosa National Wildlife Refuge). The dashed lines indicate that down stream of Capulin the Alamosa River and La Jara Creek are channelized and the subsurface hydrology of these streams is poorly understood.

### Wetland samples

Sediment, water, and wetland plants were collected from nine areas within wetlands just west of (Sites O, P1, P2, Q, and R) or within (Sites L, M, N, and S) the Alamosa National Wildlife Refuge (fig. 1). The character of the wetlands was variable and included permanent (M and S) and small evaporative ponds (P2), wetlands along sloughs (L), oxbows (O), ditches (P1), and canals (N and R), and flooded fields (Q). The wetlands received surface water from different sources. The wetlands within the Refuge appeared to be topographically isolated from receiving surface water from the Alamosa River or La Jara Creek and, most likely, received surface water from the Rio Grande River. The wetlands west of the Refuge appeared to receive surface water from the Alamosa River or a combination of Alamosa River and La Jara Creek waters.

## DISCUSSION

### Dendrochemical Trends

We discuss results from the analysis of tree-rings from four separate years and from six of the 10 sites. These rings represent periods before modern mining began at Summitville (1970 and 1980), the year mining was initiated (1986), and the period during active mining (1990).

The translocation of elements between rings is a concern in the interpretation of dendrochemical trends. The small number of analyses per core in this study precludes definitive interpretation of element movement among rings; however, elements such as Br, Cl, Mg, Na, and P are mobile within some trees to some extent (Yanosky and others, 1995).

### Cottonwood

#### Lead

Except for cottonwood rings collected at Site K (the site furthest from the mine) the uptake of Pb does not show either temporal or spatial trends (fig. 2). An order of magnitude increase is present at Site K over a 30-year period. Several explanations are possible: either the amount of available Pb increased over time or the absolute amount of Pb did not change and the bioavailability of what was present did change. Baes and Ragsdale (1981) found that Pb was laterally mobile in selected southeastern hardwood tree species, i.e., Pb concentrations were greater in older than younger rings. The radial Pb concentration pattern that we observe (fig. 2) did not follow this pattern; however, our data covered only 30-40 years. The increase in Pb from older to younger rings remains unexplained.

## Lead in Cottonwood Tree Rings

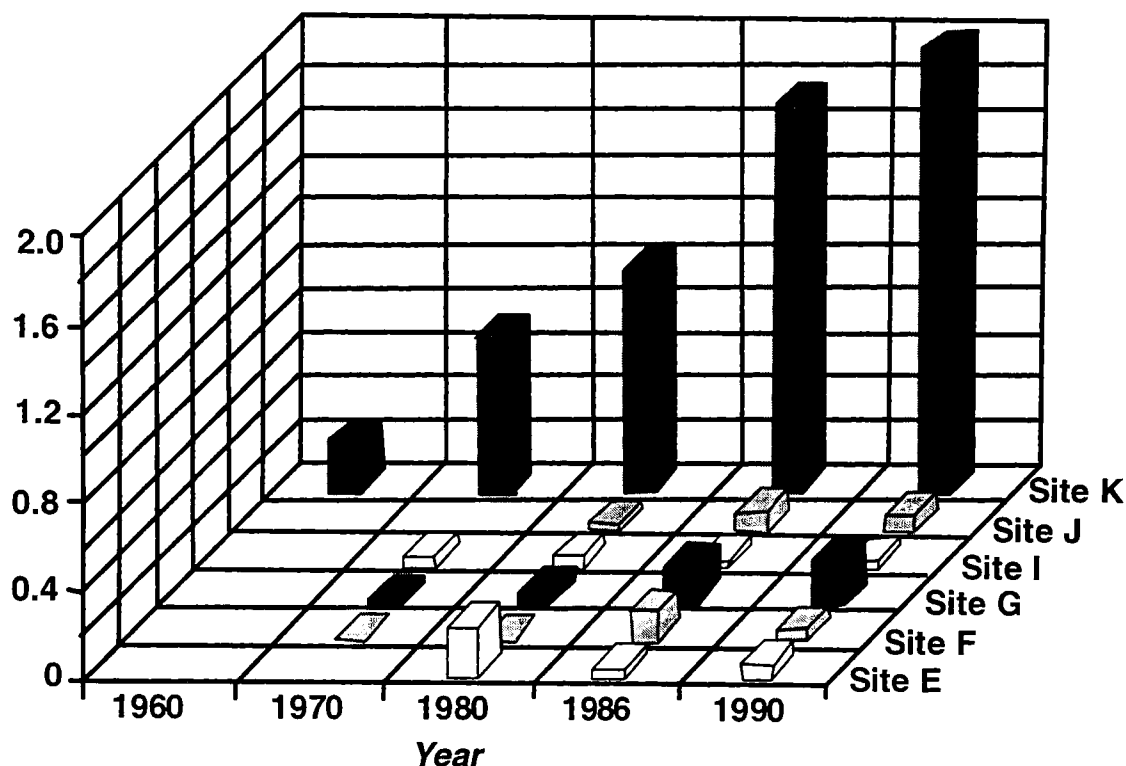

Figure 2. Lead in cottonwood tree rings (Gough and others, 1995; see Fig. 1 for position of study sites).

### Copper and Zinc

Copper and Zn are two of the major metals associated with area mineralization and are of great concern because of their toxicity to aquatic biota. High concentrations were found in the associated stream sediment and water samples (Balistreri and others, 1995). Patterns in tree rings show that (a) they are most abundant in older tissue, (b) there are no obvious down-gradient trends, (c) there is a very high correlation between Cu and Zn in both their temporal and down gradient patterns, particularly within rings from the upper sites (E, F, and G). High concentrations of Cu in ground water are toxic to tree roots and uptake inhibition is a consideration.

### Phosphorus

Both temporal and down-gradient trends are noted; P is translocated to younger tissue; P concentrations increase at Sites I, J, and K (valley floor) and may be due to agricultural input or increases in its bioavailability.

### Bromide and Sodium

In this river basin environment, Br and Na are highly mobile. In addition, both elements appear to be laterally

mobile within the trees (i.e., there is possibly some movement from younger to older rings). This mobility complicates down-gradient interpretations. The increased uptake of Br and Na at Site K is possibly due to oxic, saline soil conditions.

### Aspen

The aspen and cottonwood data are not directly comparable because they are different species, may represent different ecological physiologies, and can occupy entirely different habitats. The aspen collected were from riparian communities, however, and occupied the same basic ecological niche as cottonwood. We note only general trends and do not compare absolute element concentrations.

### Copper and Zinc

Cu and Zn are elements of environmental concern; there is no obvious impact from Wightman Fork because values above the confluence with the Alamosa River and in Wightman Fork were about the same; higher concentrations occur in older tissue.

## **Bromide**

Both temporal and down-gradient trends are possible; impact from mine drainage may be observed; highly mobile element is associated with mineralization.

## **Barium**

Both temporal and down-gradient trends are possible; impact from mine drainage may be observed.

## **River Samples**

### **Water**

Water in the Wightman Fork (Site B) was characterized by low pH values and elevated concentrations of dissolved major (Na, Ca, Mg, Cl, and sulfate) and minor (Al, B, Co, Cu, Fe, Mn, Ni, Sr, and Zn) ions relative to water in the Alamosa River above the confluence with the Wightman Fork (Site C). The Wightman Fork had a distinct influence on the composition of Alamosa River water downstream of the confluence. Values of pH were lower and dissolved concentrations of major (Na, Ca, Cl, and sulfate) and minor (Al, Cu, Fe, Mn, Sr, and Zn) ions were elevated in the Alamosa River just below (Site D) as compared to above (Site C) the confluence. Elevated dissolved concentrations of major (Na, Ca, Cl, and sulfate) and certain minor (Cu, Mn, Sr, and Zn) ions persisted far downstream (at least 49 km) in Alamosa River water. Dilution plays the major role in attenuating dissolved concentrations of ions downstream from the confluence; however, dissolved Cu concentrations far downstream also appear to be affected by a removal process such as sorption (Balistrieri and others, 1995). The dissolved chemical characteristics of the Wightman Fork and Alamosa River are variable with time and highly dependent on pH (Ward and Walton-Day, 1995; Walton-Day and others, 1995). Hence, our sampling during June 1993 only provides a single, instantaneous picture of the dissolved chemical characteristics of these rivers.

### **Sediment**

The composition of stream-bed sediments from the Wightman Fork and Alamosa River is summarized in Balistrieri and others, 1995. The data indicate that sediments in the Wightman Fork (Site B) have higher concentrations of Fe, S, As, Cr, Cu, Hg, Pb, and Zn relative to sediments in the Alamosa River above the confluence with the Wightman Fork (Site C). Of these elements, Cu and As show the greatest enrichment (13.5 to 14.2 x). Sediments in the Alamosa River downstream of the confluence with the Wightman Fork tend to have higher concentrations of As, Co, Cr, Cu, Ni, and Zn relative to sediments above the confluence (Site C). Higher concentrations of Co, Ni, and Zn in Alamosa River sediments tend to occur much farther downstream (>18–29 km from the confluence) than the other elements.

The composition of water and sediments in the Wightman Fork most likely reflects drainage from the

Summitville Mine; however, enrichments of elements in the Alamosa River downstream of the confluence with the Wightman Fork also include elements supplied by other streams and from diffuse runoff. Based on the compositional data of Wightman Fork and Alamosa River, the following elements appear to be indicative of drainage from mineralized areas in this watershed: Al, As, B, Co, Cr, Cu, Fe, Hg, Mn, Ni, Pb, S, Sr, Zn. Some of the minor elements (e.g., As, Co, Cr, Cu, Ni, and Zn) are enriched far downstream of the confluence with the Wightman Fork. This latter group of elements is used as potential tracers or indicator elements for assessing the impact of drainage from mineralized areas on wetlands in the San Luis Valley.

## **Wetland Samples**

### **Water**

The composition of surface water in selected wetlands in the San Luis Valley is summarized in Balistrieri and others, 1995. In June 1993, the wetlands were alkaline (pH > 7), had variable dissolved major ion (e.g., Na, K, Ca, Mg, Cl, and sulfate) concentrations, and low concentrations of many minor ions (e.g., Co, Cu, Ni, and Zn). Variations in the major ion chemistry of the water and our observations of salt crusts in the vicinity of many wetlands suggest that evaporation was occurring and causing the concentration and precipitation of certain dissolved elements. The low concentrations of the minor cations are consistent with their ability to sorb onto particles or precipitate at higher pH values (Stumm and Morgan, 1981). In contrast, the mobility of anions, like As, is usually greater at the higher pH values observed in the wetlands due to lower sorption of anions at high pH (Pierce and Moore, 1982). Dissolved concentrations of As tended to be higher in wetlands within the Refuge as compared to wetlands outside of the Refuge. This observation may, in part, reflect different source waters as well as the effects of evaporative concentration.

Differences in the ratio of two conservative elements, Na and Cl, between the wetlands and Alamosa River water below Terrace Reservoir provide support for different source waters. The ratio in Alamosa River water (Na/Cl = 100±4) is less than half of the ratio in wetland waters within the Alamosa National Wildlife Refuge (Na/Cl = 229±19). The ratio for wetlands west of the Refuge ranges from 114 to 189 and suggests input from the Alamosa River.

### **Sediment**

The composition of wetland sediments is summarized in Balistrieri and others, 1995. Concentrations of the indicator elements of mineral/mine influence (i.e., As, Co, Cr, Cu, Ni, and Zn) for selected wetland sediments that receive water from different sources were examined. Results indicate that sediments in wetlands that receive some Alamosa River water clearly have higher concentrations of Cu, Ni, and Zn than wetlands receiving surface water from other sources. In addition, the metal contents of sediments in

wetlands receiving Alamosa River water do not significantly change with depth. If wetlands receiving Alamosa River water received additional metals from drainage derived from open-pit mining activities at Summitville, then the down core composition of wetland sediments should change significantly provided that the collected sediment represents a time frame that brackets the beginning of open-pit mining activities at Summitville Mine (i.e., before and after 1984–1986) (Pendleton and others, 1995).

Two wetland cores (Site O core 1 and Site M core 2) were age dated using  $^{210}\text{Pb}$  techniques. Mass accumulation rates were determined from  $^{210}\text{Pb}$  activity and water content as a function of depth using a one-dimensional, two-layer, steady-state sedimentation model in which mixing occurs only in the surface mixed

layer (Robbins and Edgington, 1975; Carpenter and others, 1982). The model assumptions are that (1) the

sedimentation rate is constant; (2) there is no post-depositional mobility of  $^{210}\text{Pb}$ ; (3) the flux of unsupported  $^{210}\text{Pb}$  to the interface is constant; and (4) the deepest sample represents the amount of supported  $^{210}\text{Pb}$  in this area and is constant throughout the core. The porosities of the two cores were calculated from water content data and by assuming that the density of the dried sediment was  $2.5 \text{ g cm}^{-3}$ . The supported  $^{210}\text{Pb}$  in the sediments was estimated to be  $0.8 \text{ dpm g}^{-1}$ . Accumulation rates were calculated as  $0.74 \text{ g cm}^{-2} \text{ y}^{-1}$  at Site M (core 2) and  $0.70 \text{ g cm}^{-2} \text{ y}^{-1}$  at Site O (core 1). Sedimentation rates in  $\text{cm y}^{-1}$  do not include natural compaction and, hence, decrease with depth. The sedimentation rates are between 0.33 and 0.52 (average = 0.38)  $\text{cm yr}^{-1}$  for Site M (core 2) and 0.33 and 0.43 (average = 0.35)  $\text{cm yr}^{-1}$  for Site O (core 1).

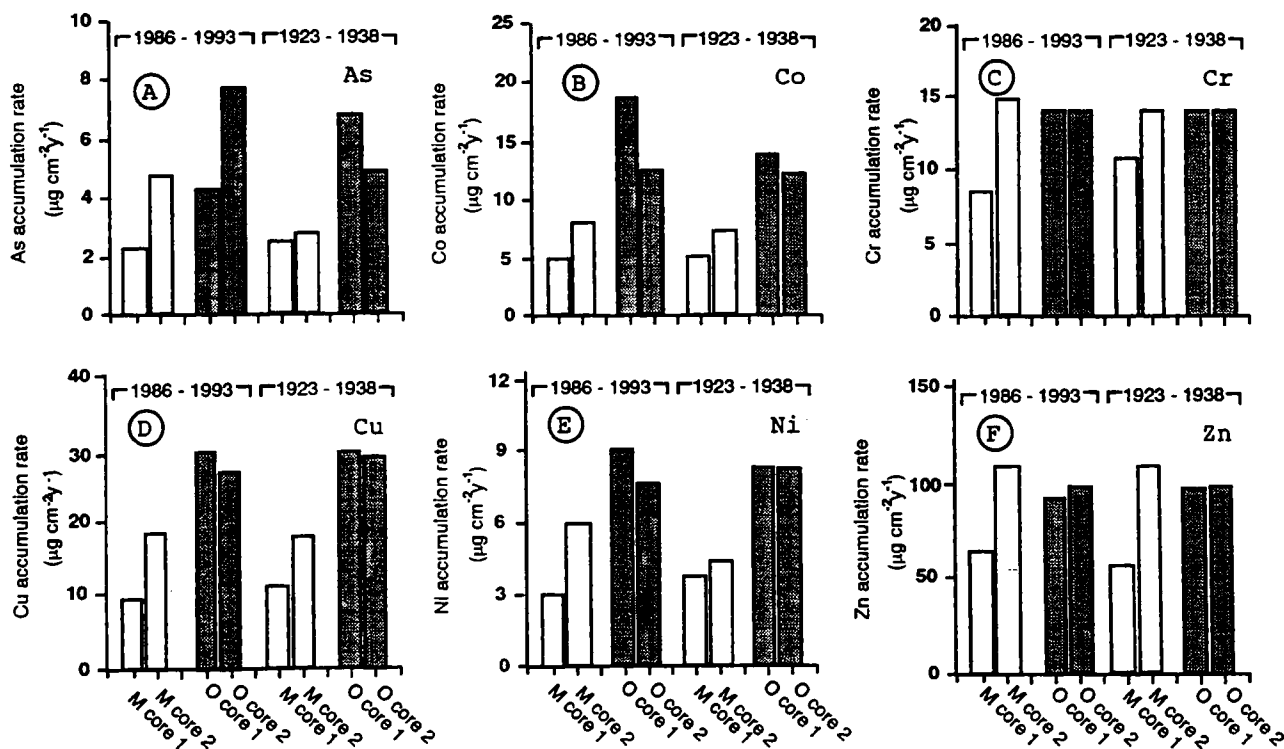

**Figure 3. Examples of accumulation rates for indicator elements at two wetland sites for two time periods: pre (1923-1938) and post open-pit mining at Summitville Mine (Balistreri and others, 1995). Site O receives Alamosa River water whereas site M receives surface water from other sources.**

Accumulation rates of the indicator elements were calculated by multiplying the metal content at a given depth by the mass accumulation rates for two time periods at Sites M and O (fig. 3). These time periods represent pre- and post-open pit mining activities at Summitville Mine. Only Site O receives surface water from the Alamosa River. We conclude (1) variations in

the metal content of the two cores collected at a given site result in a range of element accumulation rates for that site; (2) the site that receives Alamosa River water (Site O) tends to have higher accumulation rates of As, Co, Cu, Ni, and, possibly, Zn; and (3) there is little difference between accumulation rates at the site receiving Alamosa River water (Site O) for pre- and

post-open pit mining activities because there are no significant changes in metal contents down core.

Increases in certain indicator elements (i.e., Co, Cr, Cu, and Ni) in the wetlands receiving Alamosa River water compared to those that receive surface water from other sources may be related to the accumulation of Fe in the wetlands. Iron oxyhydroxides have a strong affinity for many elements and, thus, can sequester trace elements in the sediments. Higher Fe contents and accumulation rates are observed for wetlands receiving Alamosa River water. There are good correlations between the concentrations of Fe and certain indicator elements in almost all wetland sediments.

### **Aquatic Plants**

The same species of aquatic plant (*Persicaria amphibia* and *Potamogeton natans*) was not present in all of the wetlands; however, each species came from wetlands that received water from different sources.

Rooted aquatic macrophytes can assimilate dissolved metals from the water through their leaves, but most uptake is thought to occur through their roots. Therefore, their chemical composition often reflects the geochemistry of the sediments in the wetlands (Pip and Stepaniuk, 1992; Flessa, 1994).

The concentrations of the indicator elements on a dry weight basis in the aquatic wetland plants are compared for wetlands receiving surface water from different sources. Both *P. amphibia* and *P. natans* growing in wetlands receiving Alamosa River water tend to have higher concentrations of Co and Cu. Zinc also appears to be enriched in *P. amphibia* in wetlands receiving Alamosa River water. These observations are consistent with the enrichment of these elements, particularly Cu and Zn, in the sediments of wetlands receiving Alamosa River water. In contrast, aquatic plant concentrations of As tend to be higher in wetlands receiving water from other sources. Dissolved concentrations of As also tended to be higher in these wetlands.

### **SUMMARY**

The element concentration levels in tree rings (dendrochemistry) of cottonwood and aspen, stream sediment, and surface water were examined at 10 sites along the Wightman Fork and Alamosa River in southern Colorado. Tree-ring chemistry is used to chart potential spatial (down gradient) and temporal (over about 30 years) trace metal trends in drainage waters. Preliminary results for Ba, Br, Cd, Cu, Na, P, Pb, and Zn are presented. Spatial and temporal trends are noted; however, cause and effect relations are hard to establish with these data. Results for Cu and Zn do not show a clear association with mine drainage; trends for P are complicated by valley soil conditions and agricultural practices. The analytical method proved especially suited to this type of study.

Concentrations of As, Co, Cr, Cu, Ni, and Zn in surface water were used as possible tracers of acidic,

metal-enriched drainage from mineralized areas in the Alamosa River watershed. These elements appeared to be transported throughout the Alamosa River system downstream of its confluence with the Wightman Fork.

The composition of surface water in selected wetlands in the San Luis Valley appeared to be affected by evaporation during June 1993. These waters tended to be alkaline and have low dissolved concentrations of all of the indicator elements, except As.

The chemical composition of sediments in wetlands receiving surface water from the Alamosa River or Alamosa River and La Jara Creek tended to be enriched in Fe, Cu, Ni, and Zn relative to sediments of wetlands receiving surface water from other sources. A comparison of metal accumulation rates in two wetlands receiving water from different sources indicates that the wetland receiving surface water from the Alamosa River has higher accumulation rates of Fe, As, Co, Cu, and Ni. The higher concentrations and accumulation rates of certain indicator elements in wetlands receiving some surface water from the Alamosa River appear to be related to the content and accumulation of Fe. However, there are no major differences in the accumulation rates or down core concentrations of indicator elements during the past 70 to 100 years in wetlands receiving Alamosa River water. The effects of recent mining activities (e.g., open-pit mining at Summitville) on wetland sediment geochemistry is not readily apparent.

Aquatic wetland plants (i.e., *P. amphibia* and *P. natans*) tend to have higher concentrations of certain indicator elements (i.e., Co, Cu, and Zn) in wetlands receiving Alamosa River water. These enrichments reflect similar trends observed in the sediments of these wetlands. Finally, a direct link between specific mining activities at the Summitville Mine and the geochemistry of the studied wetlands was not found. However, the studied wetlands west of the Alamosa National Wildlife Refuge that receive Alamosa River water tended to have higher concentrations of indicator elements, except As, in their sediment and aquatic plants relative to the studied wetlands within the Refuge that receive surface water from other sources. In addition, Cu appears to be the best overall indicator element for wetlands that receive water from the Alamosa River.

### **ACKNOWLEDGMENTS**

We thank Maria Montour for her assistance in the field.

## REFERENCES

- Baes, C.F., and Ragsdale, H.L., 1981, Age-specific lead distribution in xylem rings of three tree genera in Atlanta, Georgia: *Environ. Poll.*, v. 2, p. 21–35.
- Balistreri, L.S., Gough, L.P., Severson, R.C., Montour, M., Briggs, P.H., Adrian, B., Curry, J., Fey, D., Hageman, P., and Papp, C., 1995, The effect of acidic, metal-enriched drainage from the Wightman Fork and Alamosa River on the composition of selected wetlands in the San Luis Valley, Colorado: U.S. Geological Survey Open-File Report 95–568, 37 p.
- Carpenter, R., Peterson, M.L., and Bennett, J.T., 1982,  $^{210}\text{Pb}$ -derived sediment accumulation and mixing rates for the Washington continental slope: *Marine Geology*, v. 48, pp. 135–164.
- Flessa, H., 1994, Plant-induced changes in the redox potential of the rhizospheres of the submerged vascular macrophytes *Myriophyllum verticillatum* L. and *Ranunculus circinatus* L.: *Aquatic Botany*, v. 47, pp. 119–129.
- Gough, L.P., Yanosky, T.M., Lichte, F. E., and Balistreri, L.S., 1995, Preliminary interpretation of spatial and temporal trends in the chemistry of tree rings downstream from the Summitville mine: *Proceedings, Summitville Forum '95*, Colorado Geological Survey, Special Publication 38, pp. 236–243.
- Moran, R.E., and Wentz, D.A., 1974, Effects of metal-mine drainage on water quality in selected areas of Colorado, 1972–73: *Colorado Water Resources Circ.* 25, Denver, Colo., Colorado Water Conservation Board.
- Pendleton, J.A., Posey, H.H., and Long, M. B., 1995, Characterizing Summitville and its impacts—Setting the scene: *Proceedings, Summitville Forum '95*, Colorado Geological Survey, Special Publication 38, pp. 1–12.
- Pierce, M.L., and Moore, C.B., 1982, Adsorption of arsenite and arsenate on amorphous iron hydroxide: *Water Res.*, v. 16, pp. 1247–1253.
- Pip, E., and Stepaniuk, J., 1992, Cadmium, copper, and lead in sediments and aquatic macrophytes in the lower Nelson River system, Manitoba, Canada—1. Interspecific differences and macrophytesediment relations: *Archiv fur Hydrobiologie*, v. 124, pp. 337–355.
- Robbins, J.A., and Edgington, D.N., 1975, Determination of recent sedimentation rates Lake Michigan using Pb-210 and Cs-137: *Geochim. Cosmochim. Acta*, v. 39, pp. 285–304.
- Stumm, W., and Morgan, J.J., 1981, *Aquatic chemistry*: John Wiley & Sons, 780 p.
- Walton-Day, K., Ortiz, R.F., and von Guerard, P. B., 1995, Sources of water having low pH and elevated metal concentrations in the upper Alamosa River from the headwaters to the outlet of Terrace Reservoir, South Central Colorado, April-September 1993: *Proceedings, Summitville Forum '95*, Colorado Geological Survey, Special Publication 38, pp. 160–170.
- Ward, E.C., and Walton-Day, K., 1995, Seasonal variations in water quality on Wightman Fork of the Alamosa River, 1993: *Proceedings, Summitville Forum '95*, Colorado Geological Survey, Special Publication 38, pp. 183–190.
- Yanosky, T.M., Hupp, C.R., and Hackney, C.T., 1995, Chloride concentrations in growth rings of *Taxodium distichum* in a saltwater-intruded estuary: *Ecol. Appl.* 5, pp. 785–792



# A PROACTIVE REMOVAL PROGRAM AT THE BONANZA MINING DISTRICT BONANZA, COLORADO

By

Margaret W. Staub  
ASARCO Incorporated  
495 East 51st Avenue  
Denver, Colorado 80216  
and

Bence V. Close  
McCulley, Frick & Gilman, Inc.  
4840 Pearl East Circle, Suite 200W  
Boulder, Colorado 80301



## INTRODUCTION

By working together, government and private industry have found a creative and expedited solution to the environmental effects of historic mining and milling in the Bonanza Mining District. The Bonanza District is located in the northeastern San Juan Mountains of Southern Colorado near the head of the San Luis Valley (Figure 1). The approximately 2000-acre mining district is drained by the Kerber Creek watershed, which drains into San Luis Creek. This paper describes the role of ASARCO Incorporated (Asarco) in a proactive removal program at the Bonanza Mining District.

## Historical Perspective

Ore deposits were first discovered and mined in the Bonanza District in the late 1800's. Prior to 1902, production from the Rawley Mine, which was one of the largest mines in the District, was small because the ore was of comparatively low grade for shipping and treatment at that time. In 1902, a 100 ton/day mill was constructed on the south side of Rawley Gulch near the Rawley Mine, and mine production occurred between 1902 and 1905. However, operation of the mill was unsuccessful because water flows in Rawley Gulch were inadequate to run the mill at capacity for more than a short time each year. Between 1905 and 1910, work focused on development of the mine. In 1910, the mine had been developed to a depth of 600 feet, or to the "6th" level (approximately 200 feet below the base of the adjacent Rawley Gulch).

During 1911 and 1912, a 6200-foot-long drainage and haulage tunnel, referred to as the Rawley 12 adit, was constructed between Squirrel Creek and the Rawley Vein, 600 feet below the 6th level (at the 1200-foot or "12th" level). After encountering the Rawley Vein, the mine workings above the 6th level were completely drained in less than 40 days, facilitating further mine development.

In 1916, preparation of the mine and planning for a 300

ton/day mill near the Rawley 12 portal in Squirrel Gulch began. The mill in Squirrel Gulch ("Rawley Mill") was not completed until 1923. An aerial tramway extending from the new mill site about 7.25 miles north to Shirley, Colorado was constructed to deliver concentrates to the Denver & Rio Grande Railroad. Along with construction of the Rawley Mill, a 40-foot-high timber crib dam was constructed across Squirrel Creek below the mill.

The development and mining activities in the early 1920's were conducted by the Colorado Corporation. Asarco and other creditors became involved in the Bonanza District in 1925, when the Colorado Corporation went bankrupt. Creditors of that corporation, formed a new company to operate the Rawley Mine and Mill in an attempt to recover their debts. In 1930, the Bonanza District properties were acquired in a tax sale.

After bankruptcy of the previous operators and subsequent re-organization in 1925, the Rawley Mill was remodeled and increased in capacity to 350 tons/day. The largest production from the Rawley Mine occurred between 1925 and 1930. During this period, three tailing dams were constructed across Kerber Creek downstream of the Town of Bonanza (Lower Tailings Area).

Approximately 90 percent of the production from the Rawley Mine reportedly occurred prior to 1931. The remaining production occurred intermittently through the early 1970's.

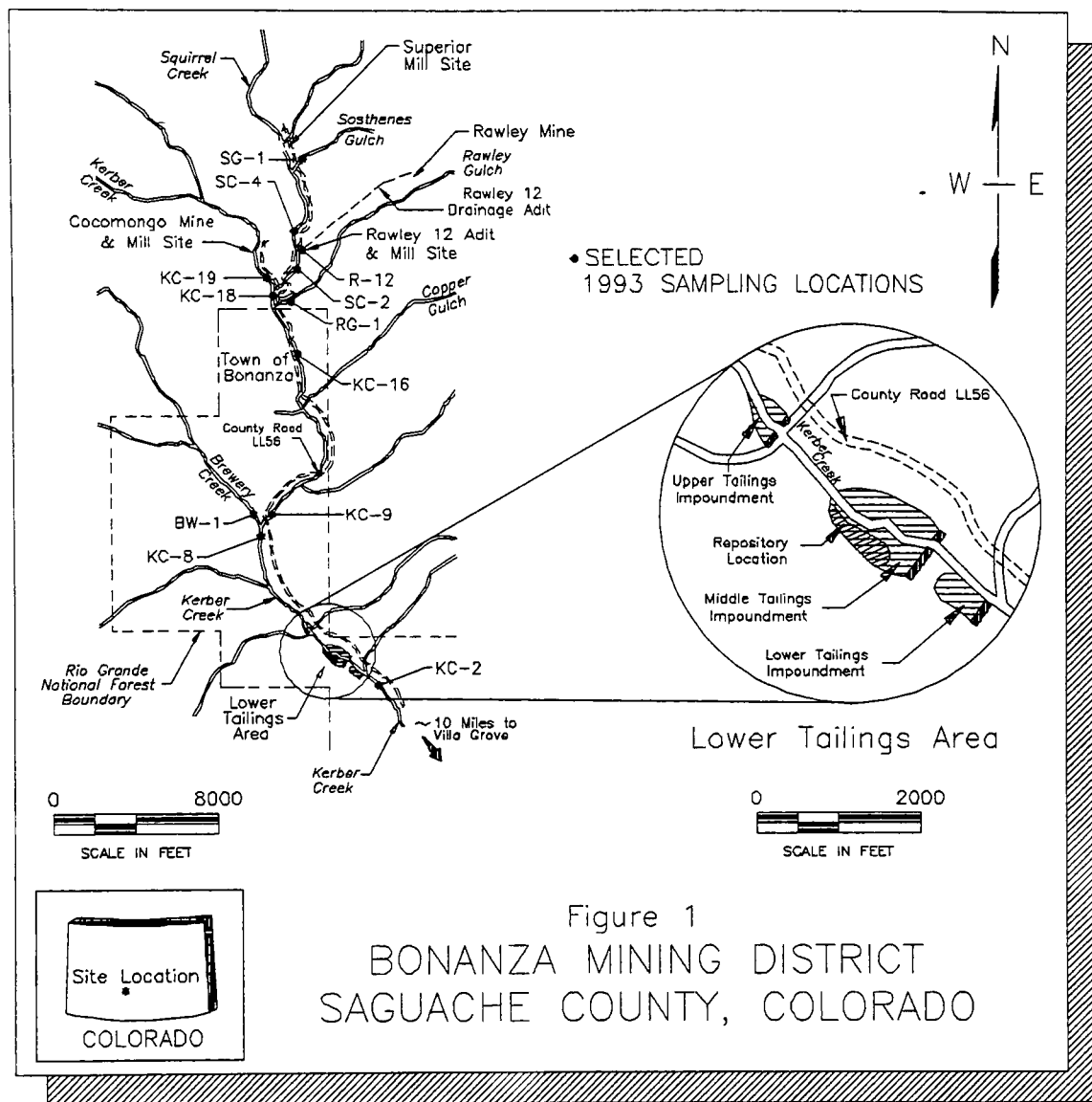

Figure 1  
 BONANZA MINING DISTRICT  
 SAGUACHE COUNTY, COLORADO

### Regulatory Perspective

Prior to 1993, the U.S. Environmental Protection Agency (EPA) and Colorado Department of Public Health and Environment (CDPHE) began evaluating the Bonanza Mining District for possible listing on the National Priorities List (NPL) as a Superfund site. In 1992, the USDA Forest Service (USFS) prepared a Preliminary Site Assessment, and later that year sent out Section 104(e) information requests under the Comprehensive Environmental Response, Compensation and Liability Act (CERCLA) to companies and individuals who had historic involvement in the District. The identified environmental issues were impacts to surface water and potential impacts to groundwater, air, and soil from historic mining and milling activities.

Upon receipt of its 104(e) notice, Asarco initiated discussions with the regulatory agencies and other private parties historically involved in the Bonanza District and assisted in organizing the private parties into what is known as the Bonanza Mining District Group (Bonanza Group). The Bonanza Group then held discussions with the CDPHE,

USFS and EPA regarding deferral of the NPL process in favor of a proactive approach to addressing the environmental concerns in the Bonanza District in a manner consistent with the National Contingency Plan (NCP).

As a result, the following agreements were reached. One, EPA agreed to defer the hazard ranking process and possible listing of the site on the NPL and to defer project oversight to the CDPHE provided efforts to address the environmental issues in the Bonanza District proceeded. Two, in cooperation with the CDPHE Water Quality Control Division, long-term water quality goals were established for the Kerber Creek watershed, which included meeting drinking water and agricultural standards in the most heavily impacted portion of the Kerber Creek watershed (above the Brewery Creek confluence), and achieving site-specific aquatic life standards in Kerber Creek below that portion. Three, the Bonanza Group agreed to address the metals loading sources linked to their involvement in the District.

The work on private lands would be performed in accordance with applicable State and Federal permits and an

agreement with the CDPHE. For work on public lands managed by the USFS, two options were available. The first option was to perform the work under the National Environmental Policy Act (NEPA), which would include preparation of environmental impact statements (EISs). The second option was to perform the work as CERCLA Time-Critical or Non-Time-Critical Removal Actions. The latter option was implemented by the Bonanza Group and the USFS due to the ability to expedite the removal activities.

## **WATER CHEMISTRY AND METALS LOADING SOURCES**

The drainages most-heavily impacted by historic mining and milling activities include Kerber Creek below the Cocomongo Mine and Mill site, Squirrel Creek, Sosthenes Gulch, Rawley Gulch, and Copper Gulch (Figure 1). The sources of metals loading being addressed by the Bonanza Group include the Superior Mill site, Cocomongo Mine and Mill site, the Rawley Mine (discharge from the 400-level adit into Rawley Gulch), the Rawley 12 Adit and Mill site, the Lower Tailings Area, and portions of creeks impacted by fluvial tailings from those areas. Numerous other mine and mill sites exist along Kerber Creek and its tributaries and also impact water quality. Asarco is cooperating with the CDPHE, USFS and Saguache County in their efforts to address these orphaned sites.

The primary constituents of concern in surface waters at the Bonanza Mining District include zinc, copper, cadmium, iron, lead, manganese and arsenic. Table 1 provides a summary of pH, specific conductance, zinc concentration and zinc loading data for selected sample sites during 1993 high-flow and low-flow conditions (pre-removal). The sampling station locations are shown on Figure 1.

The discharge rate and chemistry of water from the Rawley 12 adit are relatively constant year-round. Based on observations from the 1960's and a recently installed piezometer near the mine workings, the water level within the mine is between the 400- and 500-foot mine levels. The mine apparently is saturated to this level as a result of collapses within the main shaft and/or the Rawley 12 adit near the main mine workings. The Rawley 12 adit was last rehabilitated to the Paragon Fault zone, about 4000 feet in from the portal, in the late-1960's. The mine was not drained as a result of these rehabilitation activities. In the early 1970's, the pH of the adit discharge was reported to be approximately 3.5. Several years thereafter, the portal apparently collapsed, limiting oxygen inflow to the mine and using the pH of the discharge to rise to approximately 5.56.

A portion of the Rawley 400-foot level adit lies beneath the base of Rawley Gulch adjacent to the mine. Discharge from this adit appears to originate from some combination of infiltration of Rawley Gulch streamflow into the mine, local infiltration of precipitation into upper mine workings, and vent inflow from other shallow mines near the Rawley mine. Adit discharge also occurs from several other mines along Rawley Gulch that are not associated with the Rawley

Mine.

Downstream of Squirrel Creek and Rawley Gulch, fluvial tailing deposits and mine waste rock from mine and mill sites along Kerber Creek also affect water quality.

## **WATER QUALITY GOALS**

Brewery Creek provides a major source of dilution to Kerber Creek, which allows for more-stringent long-term stream classification goals for Kerber Creek downstream of the Brewery Creek confluence. The long-term goals for the mining-impacted portions of the Kerber Creek watershed above the Brewery Creek confluence are to achieve drinking water and agricultural use standards. Below the Brewery Creek confluence, the long-term goal for Kerber Creek is to establish water quality suitable for brook trout. In order to facilitate the removal activities, the Colorado Water Quality Control Commission issued a temporary modification allowing ambient water quality until the removal activities progressed. The removal actions performed by the Bonanza Group are being conducted in a manner that is consistent with anti-degradation standards and achievement of the long-term water quality goals.

## **REMEDY DEVELOPMENT**

### **Administrative Process**

The remedy being implemented at the Bonanza District was selected through a series of cooperative arrangements between CDPHE, USFS, the Bonanza Group, Saguache County, and the Town of Bonanza. At the onset of the project, Asarco and the Bonanza Group retained the environmental science and engineering consulting firm of McCulley, Frick & Gilman, Inc. (MFG), which has provided technical and administrative management of the Bonanza Group activities, performed agency liaison and negotiations, performed sampling activities, developed work plans and reports, secured permits, developed conceptual and final design and contract documents, and performed construction management and other activities associated with development and implementation of the remedy. Asarco's construction contractor has been SLV Earth Movers Inc. of Monte Vista, Colorado.

Although the removal actions are being conducted in accordance with CERCLA and the NCP, the traditional method for selecting a remedy through the rigorous CERCLA Remedial Investigation/Feasibility Study (RI/FS) has not been applied. Asarco agreed to prepare a focused remedy-screening and Engineering Evaluation/Cost Analysis (EE/CA) document, which was submitted to the CDPHE and USFS for approval and subjected to the NCP process, including public review and comment. One of the major criteria for remedy selection was achievement of long-term water quality goals, established by the Water Quality Control Commission on the basis of use attainability assessments and habitat evaluations performed by MFG and the Water Quality

Control Division.

To implement the remedy, roles of involved parties were identified in a document called the Statement of Roles and Responsibilities (SRR), which was signed by the CDPHE and the Bonanza Group. This document identified the oversight

**Table 1. Summary of Selected 1993 Chemistry Data**

Sample Location	High-Flow Event (June)					Low-Flow Event (September)				
	Discharge (cfs)	pH (units)	Specific Conductance (µS/cm)	Dissolved Zinc (mg/L)	Dissolved Zinc Loadings (lbs/day)	Discharge (cfs)	pH (units)	Specific Conductance (µS/cm)	Dissolved Zinc (mg/L)	Dissolved Zinc Loadings (lbs/day)
SG-1	0.281	4.60	863	42.9	65.0	0.0025	3.98	728	9.41	0.127
SC-4	6.59	7.00	178	1.60	56.9	0.15	7.47	382	0.289	0.234
R-12	0.47	5.82	1210	57.2	145	0.63	5.80	1252	45.1	153
SC-2	7.93	6.60	239	4.64	198	0.40	5.21	1048	35.1	75.7
KC-19	18.3	7.54	60	0.043	4.24	0.37	5.88	575	0.032	0.064
KC-18	27.6	7.01	109	1.34	199	0.40	6.09	527	17.3	37.3
RG-1	3.20	4.62	292	8.18	141	0.18	3.55	430	14.2	13.8
KC-16	31.1	6.90	111	1.88	315	1.06	5.40	491	16.7	95.5
KC-9	38.7	7.08	113	1.61	336	1.94	6.14	367	9.39	98.3
BW-1	39.2	7.29	55	<0.007	0.74	1.57	6.74	124	0.028	0.237
KC-8	75.2	7.30	84	0.700	284	4.02	6.39	249	4.68	101
KC-2	79.9	7.98	101	0.755	325	3.70	6.31	266	4.60	92

role of the CDPHE as well as the Bonanza Group's commitments including deliverables, monitoring requirements, and a general schedule for remedy implementation.

A second agreement, a Memorandum of Understanding (MOU), was entered into between the USFS and the CDPHE, which defined agency management and oversight roles for activities conducted on public versus private lands. The USFS assumed management of activities conducted on public lands pursuant to its CERCLA authority. The CDPHE assumed the lead for work conducted on private lands and assumed general site oversight responsibilities. Work on private lands has been conducted pursuant to applicable State and Federal permits.

As part of Saguache County permitting requirements and NCP public input requirements for a CERCLA Non-Time Critical Removal Action, Asarco participated in a public meeting near Bonanza prior to any construction activities. In addition, Asarco met with representatives of the Town of Bonanza, which had approximately ten year-round residents, and reached an agreement with the town regarding noise control, speed limits and traffic control. Prior to

construction, Asarco also worked with Saguache County to provide improvements to roads that may potentially be impacted by construction activities. In addition to involving the local public in the process, Asarco's construction contractor hired local workers and used locally available equipment, when feasible. As a result of Asarco's outreach efforts with the Town of Bonanza, construction activities have moved forward with overall support from the community. Local land owners have cooperated by providing access to perform sampling activities, conduct the removal activities and develop a site repository for tailings consolidation and closure. In addition, local land owners have cooperated with Asarco on water rights issues and the development of a local limestone quarry, which is supplying limestone to the project.

### Technical Process

Technical implementation of the proactive removal plan began with semi-annual surface water monitoring throughout the Bonanza District during high-flow and low-flow conditions. In addition to the surface water quality monitoring, monitoring has been performed to assess the

aquatic biology within and downstream of the District. The water quality and biological monitoring events have served to establish baseline conditions and assisted in the development of long-term water quality goals. In conjunction with the monitoring and as part of the process of negotiating stream standard and classification goals, use attainability assessments and pre-removal aquatic habitat evaluations were also performed. Currently, semi-annual water quality monitoring is used to develop additional baseline data in some areas as well as track improvements in water quality as a result of the removal activities.

Program implementation evolved rapidly after formation of the Bonanza Group in May 1993, beginning with development of Conceptual Management Plans and schedules for each area of Group involvement. These conceptual plans formed a technical basis for the initial Group/Agency agreements. Asarco's plans were further developed in a document which addressed EPA guidance for development of an EE/CA and a Feasibility Study. Other plans and design documents have been prepared as required to satisfy State and Federal permit requirements for work on private lands and the requirements for Time-Critical and Non-Time-Critical Removal Actions on the public lands.

Permits and authorizations for the work on private lands have included a Certificate of Designation and associated land use changes from Saguache County for the tailings repository, a construction stormwater permit from the CDPHE, a Clean Water Act Section 404 Nationwide Permit from the U.S. Army Corps of Engineers, an Air Pollution Emissions Notice (APEN), and water use agreements with water rights holders. Numerous plans and reports have been prepared in support of permits, CERCLA Removal Actions and the Statement of Roles and Responsibilities. These have included annual work plans and EE/CA's, sampling and analysis plans and reports, an engineering design and operations report for the solid waste permit for the tailings repository, a Bonanza Group site ownership and production report, a geologic mapping report for the Rawley Mine and Rawley 12 adit, construction stormwater management plans, site health and safety plans, traffic control plans, construction plans and specifications, construction management plans, a site operation and maintenance plan, a monitoring and control plan for Rawley 12 adit construction activities, and annual construction completion reports.

In order to address EPA concerns regarding potential human health risks due to fluvial deposits of tailings in the Town of Bonanza, the Bonanza Group, in coordination with the CDPHE, collected and analyzed soil samples from residential yards for lead and arsenic. The results of the investigation indicated that there were no significant health risks from residential yards as a result of fluvial tailings deposits.

## REMEDY IMPLEMENTATION

### Removal Action Overview

Asarco has implemented and/or developed plans to address environmental impacts from several sources within the Bonanza District, including the discharge from the Rawley 12 adit, discharge from the upper workings of the Rawley Mine into Rawley Gulch, the tailings impoundment below the former mill located adjacent to the Rawley 12 portal, and tailings in the three impoundments along Kerber Creek below the Town of Bonanza (Figure 1). The overall removal action will consolidate tailings and other mine wastes into the permitted solid waste landfill (repository) at the Lower Tailings Area. For the Rawley Mine, if feasible, one or more plugs will be installed to reduce mine discharges and acid-generation within the mine workings. Remaining flows would be addressed as necessary through the use of passive treatment systems.

Removal work at the Superior Mill and Cocomongo Mine and Mill sites is anticipated to be completed by other members of the Bonanza Group. This work is expected to include consolidation, regrading and capping of tailings and mine waste rock, stormwater diversions, revegetation, and riparian zone enhancements.

### Construction Phases

The first phase of construction activities (Phase 1) was performed in 1994 at the Rawley 12 Area and included excavating tailings from the Rawley 12 Area, and moving these tailings to an interim repository at the Lower Tailings Area. The relocation of the Rawley 12 tailings involved dismantling the timber crib dam and excavation and hauling of approximately 31,000 cubic yards of tailings through the Town of Bonanza to the repository.

Work performed during 1995 (Phase 2) at the Lower Tailings Area included removal and consolidation of approximately 85,000 cubic yards of tailings from the three tailing impoundments into the repository, regrading of these removal areas, and soil amendment and reseeding at the upper impoundment. Other Phase 2 work included regrading a portion of the Rawley 12 tailings removal area; diversion of flows in Rawley Gulch around the upper workings of the Rawley Mine; miscellaneous stormwater and sediment controls; development of a limestone quarry in the Bonanza area; and production and stockpiling of limestone to be used for repository capping, soil amendment, and erosion protection.

Construction work related to the Rawley Mine in 1996 (Phase 3) includes drilling and installation of a piezometer to monitor water levels in the mine, construction of a lined surge and oxidation and sedimentation pond at the Rawley 12 adit portal, opening and reconstruction of the Rawley 12 adit portal, and rehabilitation and geologic reconnaissance of the adit. The purpose of the adit rehabilitation and geologic reconnaissance is to investigate the feasibility of installing an adit plug approximately 3000 feet inward from the portal.

The portal pond will provide passive treatment of the

adit drainage via oxidation and precipitation of iron and other metals. Contingencies will also be in place for active water treatment (pH adjustment) in the pond. In addition to treating the adit drainage, the pond will detain potential surge flows from the adit that may occur during the adit reconnaissance and construction activities.

Other work proposed for 1996 at the Rawley 12 Area includes reclamation of the Squirrel Creek channel and adjacent tailings removal areas. Squirrel Creek will be modified and stabilized to provide flood protection for the oxidation/sedimentation pond, the adjacent roadway embankment, and the reclaimed area. Revegetation and riparian-zone enhancements will also be included along the modified portion of Squirrel Creek.

Construction work proposed for 1996 at the Lower Tailings Area includes rehandling and compacting wet tailings stored at the repository in 1995, regrading of the repository and staging of materials in preparation for closure, maintenance of sediment control structures, and construction of a sludge dewatering bed for handling sludges removed from the Rawley 12 adit and/or portal pond.

Construction work anticipated by Asarco for 1997 (Phase 4) includes partial closure of the repository, reclamation of additional tailings removal/impacted areas and associated creek rehabilitation, and possible further adit rehabilitation and plug construction in the Rawley 12 adit, if plugging is determined to be feasible. The scope of additional removal activities associated with the Rawley Mine are dependent upon the feasibility and/or success of a Rawley 12 adit plug.

Longer term, Asarco intends to provide post-closure care and maintenance of the tailings repository and other constructed works, as necessary or required by permits.

## DISCUSSION

The process in place at the Bonanza Mining District is an excellent example of how industry and regulatory agencies can work together in an amicable fashion to resolve environmental issues on public and private lands. The success of the proactive removal program is founded on open communication and cooperation between the Bonanza Group, MFG, the construction contractor, CDPHE, USFS, EPA, Saguache County, and the Town of Bonanza. In contrast to the numerous years of study typically performed prior to initiating large-scale removal actions at similar sites, the cooperative relationships on the Bonanza project resulted in on-the-ground construction only 16 months after the initial meeting between the Bonanza Group and the regulatory agencies. Issues that remain to be addressed include certain orphan sites and other non-mining impacts in the area, such as agriculture, that may affect the ability to achieve long-term water quality goals.



# THE SAN LUIS MINE

By  
Sally Hayes Kaiser  
Battle Mountain Resources, Inc.  
P.O. Box 310  
San Luis, CO 81152



## INTRODUCTION

The San Luis Mine is located on the western slope of the Sangre De Cristo Mountains adjacent to the San Luis Basin and about 3½ miles northeast of the town of San Luis. A permit to mine was approved by the Department of Natural Resources, Division of Minerals and Geology (DMG). Construction began in 1989 -1990.

Battle Mountain Resources, Inc. (BMRI) holds air, stormwater, water rights, waste, safety, explosive, and reclamation permits.

- BMRI's air permits state that fugitive dust must be controlled from the mine site. BMRI was required to monitor Particulate Matter less than 10 microns (PM10) every three days for 1 year at the mine site. BMRI monitored PM10 for 5 years with only one exceedance. This exceedance was discounted because of very high winds that day. BMRI continues to monitor wind direction, wind speed, temperature, and precipitation. BMRI is required to keep opacity (visible emissions) below set limits on the haul roads, at the top of the leach tanks, at any discharge pipes, at the crusher, etc. Two employees on site are tested every six months by the state on identifying opacity levels and are then certified to measure opacity. These two employees take opacity readings daily.

- BMRI's stormwater permit maintains best management practices for the control of sediment from entering area drainages. BMRI is required to maintain stormwater ditches, check dams, and sumps twice a year. In actuality, these areas are checked almost monthly.

- BMRI, through Colorado Water Court Case No. 89CW32, is required to augment water taken from a dewatering well, used to keep the pit dry for mining, back into the Rito Seco. The Water Court Case allowed BMRI to change point of diversion water use for existing water rights as well as requiring augmentation. This

augmentation water comes from a farm ten miles away, purchased by BMRI. BMRI put in a pipeline from the farm to the mine site in order to supply water to the mine and for augmentation. Three to four irrigation fields are left dry and planted with dryland grasses in order to compensate for the water taken. In any one year, the mine site will use much less water than the farm. The water that is taken from the dewatering well must be sent directly to the tailings ponds. BMRI does not send this water directly back to Rito Seco because analysis of the water shows that it is periodically above drinking water standards for gross alpha radiological chemistry. Stream gauging of Rito Seco does not show that the dewatering well depletes the creek, yet BMRI is required to augment the dewatering well water due to the closeness and possible connection to the Rito Seco alluvial flows.

The San Luis Mine is a zero discharge facility and is located in a net evaporation environment; the Summitville Mine was located in a net precipitation environment.

- BMRI also holds a small quantity generator permit with the Environmental Protection Agency (EPA). This permit allows for the storage of only small quantities of hazardous waste for limited time periods.

- BMRI conducts all mining activities under the strict rules of the Mine Safety and Health Administration (MSHA). BMRI is routinely inspected by MSHA. BMRI holds an excellent safety record. This is attributable to the excellent workforce and safety training.

- BMRI holds a permit through the DMG to use explosives in order to break up the hard rock for mining.

- BMRI's reclamation permit was also issued by the DMG. This permit is the most extensive of all mine permits. This permit allows BMRI to mine and process the ore and mandates how the area will be reclaimed afterward.

## RECLAMATION

BMRI chose to include concurrent reclamation in the mining schedule. Reclamation, by definition, is the treatment or manipulation of a disturbed site. The definition of reclamation can be interpreted as helping mother nature accelerate productivity.

Great advances have been made in reclamation technology in the past twenty years. Probably the most significant of these has been the "domestication" of many species—especially native species—for revegetation, and the development of commercially available sources of seed and nursery stock. With the emphasis on diversity as a desirable trait of reclaimed landscapes it is not uncommon to use seed mixtures for reclamation containing twenty or more species. Such mixes would not have been feasible in the West ten years ago.

Despite the progress that has been made in reclamation technology, reclaiming high elevation disturbances remains problematic. Problems include harsh climatic conditions, marginal or unsuitable soils, very short growing seasons, lack of adequate supply of water, and a short or non-existent supply of seed of adapted plant species. And good initial stands can die out altogether.

The first step to successful reclamation is a site characterization. This characterization includes baseline studies, determination of past and future uses of the land, and biological, ecological, geological, hydrological, climatological, and environmental studies. Baseline water quality sampling began at the San Luis Mine in November 1987 and water quality sampling has continued since then. Climatological studies and air sampling have been continuous since operations began. The biological, ecological, geological, hydrological, and environmental studies can all be found in the approved permit and ongoing environmental activities at the site.

Past land uses of the general area of the San Luis Mine have been principally rangeland for grazing of domestic livestock and as an open space for wildlife habitat. Grazing pressure currently ranges from low to moderate. Other present and past land uses are recreational fishing and picnicking along the Rito Seco, cutting of trees for firewood, and some previous mining and mineral exploration activities (i.e. a small mine and heap leach were developed in the project area in the 1970's, and exploration programs have continued since that time). Areas to the north, south, and east of the project were divided into large lot housing plots and an extensive road system has been constructed to access these plots. The area supports mostly sagebrush on the flats and lower slopes with piñon and juniper trees on the steeper upland slopes. The climate at this elevation in southern Colorado is warm and dry in the summer and cold with snow and rain in the fall, winter, and spring.

Following reclamation, the land should be able to support the same level of productive uses that existed prior to mining, including wildlife, agricultural, and recreation.

Return of lands does not happen without effort, particularly in the arid west. Approved land uses after mining are to reclaim rangeland and to create an open space for wildlife habitat. At San Luis, BMRI intends to improve productive uses that existed prior to mining. Revegetation is planned to improve range conditions by planting a higher proportion of desirable forage grasses. Not only does this vegetative growth provide aesthetic qualities and erosion control, it also provides food and cover for wildlife. Because the area is currently dominated by sagebrush and supports sparse grass cover, both wildlife and range conditions will benefit from a diverse grassland community. Waste rock disposal areas and pits are recontoured to conform to the surrounding land or at least to an aesthetically pleasing form and integrated into the natural topography.

Our goal in revegetating is to establish a mature plant community on-site that is capable of reproducing itself year after year. In order to provide an environment that can produce the desired results, slope and growth medium stabilization is necessary. Extensive slope stability and reclamation studies conducted by the U.S. Forest Service in conjunction with mine operators in Central Idaho concluded that the optimum average outslope is 3:1. An average slope of 3:1 decreases the runoff velocity, allowing for runoff infiltration and minimizes growth medium erosion.

When construction is completed on each lift of a waste rock disposal area, the outslope is reclaimed. The building of subsequent benches proceeds concurrently with the reclamation of lower benches. The slopes are graded to allow 15 foot (dozer width) benches. These benches allow for sediment collection and erosion control. Vegetation of the lower slopes provides some filtration for sediment that might be present in runoff from upper unreclaimed slopes of the waste rock disposal areas. A small catch basin is left as each subsequent lift is graded and this bench provides a mechanism for slowing runoff from the slopes and allowing collection of sediment. As a result, all the active waste rock disposal areas have had their lower slopes reclaimed. This provides immediate stormwater management benefits through minimizing exposure of the waste rock and providing vegetative stabilization. Vegetative establishment reduces sediment generation and on the lower slopes it will provide some filtration for sediment that might be present in runoff from upper unreclaimed slopes of the waste rock disposal areas. Other stormwater management procedures implemented include controlling erosion and sedimentation by constructing drainage ditches, berms, settling basins, and small check dams.

Sediment runoff and soil erosion from exposed surfaces is minimized by diverting upslope runoff through diversion ditches into sumps where sediments are allowed to settle. These sumps and ditches are cleaned out periodically.

The heap leach area developed by Earth Sciences, Inc. (ESI), developed in the project area in the 1970's, had completely revegetated through natural invasion without growth medium replacement, fertilizer, or seeding. Several varieties of shrubs, trees, grasses, and wildflowers were observed flourishing in this rocky, soil deficient environment. This area blended quite well with the surrounding vegetation, suggesting that successful reclamation of disturbed areas, proposed as part of the San Luis Project, will be achieved. Testing of the area showed recoverable gold and additional testing by BMRI showed no cyanide. BMRI removed the spent ore, folded in and graded over the concrete pool and plastic pond liners, and covered the entire area with growth medium and reseeded.

The first pit to be mined by BMRI was the East Pit. This pit has been backfilled with approximately two million tons of waste rock from the West Pit. Benches of approximately 15 feet wide are maintained to aid in sediment and erosion control. The lowest bench was left to approximate the original contour. Backfill was placed in a style that blends with the surrounding topography. Following backfill placement, growth medium was distributed to a depth of 12 to 18 inches. The area was revegetated with the approved seed mixture and 2,500 seedlings of piñon and juniper have been planted. Piñon and juniper trees are drought resistant, native species. The piñon provide fatty seeds that are beneficial for mammals during wintertime. They adapt well on steep grade hillsides and their roots are horizontal spreaders that help in preventing erosion.

## **PERMIT MODIFICATION**

In 1994, BMRI requested from the DMG, a modification to our permit. This modification addresses a change in waste rock disposal plans to include partial backfilling of the West Pit to a level that will allow the below surface area (southern portion) to have positive drainage. The improved plan results in eliminating one waste rock disposal area, reducing the size of another waste rock disposal area, and providing temporary waste rock storage at a third disposal area before eventual removal and placement in the pit. The approved permit boundary will not change as a result, but the size of certain waste rock disposal facilities will change. Overall net disturbance of land will decrease as a result of the modification. Partial West Pit backfilling also eliminates the long-term stability concerns associated with the south

wall adjacent to Rito Seco, and the requirement for a partial backfill rock buttress.

The stockpiling of waste rock on Waste Rock Disposal Area B will temporarily increase the height of the waste pile until this material is removed for backfilling into the West Pit. Waste rock will be backfilled into the West Pit to an elevation of approximately 8,600 feet. The results of a recent hydrogeologic evaluation indicate that following closure the groundwater level within the pit area will rise to an elevation of approximately 8,570 feet, and the groundwater flow system will return to a regime similar to the pre-mining conditions.

A laboratory testing program to geochemically characterize the waste rock from the San Luis Mine was outlined in the approved permit. Additional geochemistry work has been performed in association with the backfill of the West Pit. The results from the testing program indicated that no acid production or leaching of degradational quantities of any metals or other constituents from the waste rock are expected to occur.

The backfill of the West Pit will be comprised of two geologic units, the Santa Fe Formation and Precambrian Pink Gneiss. The Santa Fe Formation is interbedded with silts, sands, and gravels of Tertiary age. Regionally, the Santa Fe Formation is known to include caliche layers that impart a significant acid neutralization potential. It is well known that in Santa Fe aquifers, high carbonate alkalinity is present. Three separate samples of Santa Fe material were further tested from the mine site. The samples were leached using EPA Method 1312. Results showed that the Santa Fe material does not leach metals.

Ten samples of Pink Gneiss underwent static acid-base accounting. This data shows that there is discernible acid neutralizing potential in the samples. The static leaching showed that the only cations leachable at levels above 1 ppm were calcium and potassium.

Humidity Cell Tests (HCT) are conducted quarterly on tailings samples. These tests support the inference that acidic leachates or leaching metals do not pose a risk to water resources from the San Luis Mine. The HCT samples produce excess carbonate alkalinity and do not produce acid. The alkalinity values are not high enough to indicate that there is residual lime in the tailings samples, which could bias the test. Tests are run until sulfates fall below detectable levels. Metals are essentially unleachable from the tailings material, even under the stressful geochemical conditions of the HCT.

Once the West Pit is backfilled and water returns to an elevation of 8570', there will no longer be the potential for point-source discharge of water from the waste rock into the surface-water flow system. Under the fully saturated condition and with the original groundwater flow system largely restored, the flux of oxygen to the inundated

materials will be greatly reduced compared to the current condition.

Sequential Batch Tests allow a rapid and relatively simple evaluation of changes that may occur over time. In order to conduct these tests, groundwater from the dewatering well was collected to ensure more accurate results. These tests show that the gneiss is not acid generating under fully saturated conditions, even when the groundwater reacting with the rock has discernible amounts of dissolved oxygen and has a positive redox potential. The only metal that appears to be leachable from the gneiss at values that are above the detection limit is manganese. This observation is expected and confirms the reliability of the testing procedures since baseline studies show manganese in the groundwater. Therefore, under fully saturated conditions, such as will be reestablished in the backfilled West Pit, the Pink Gneiss is not acid generating, does not leach significant concentrations of any metal save manganese (and that only at a maximum of about 1 ppm), and is not expected to adversely affect any beneficial use of groundwater or surface water near the Mine.

In the unlikely event that mining is terminated any time prior to completion of the full mine plan, an alternative reclamation plan will be implemented. To provide for the event of early closure, BMRI has increased the reclamation bond from \$3,300,000 to \$6,300,000 to cover additional costs associated with pit backfilling.

The following table is a list of permitted disturbance areas and their acreage, the table also shows acreage under reclamation.

<u>Disturbance Area</u>	<u>Acres</u>	<u>Under Reclamation</u>
East Pit	20	20
West Pit	110	34
Waste Rock Disposal area A	0	0
Waste Rock Disposal area B	18	8
Waste Rock Disposal area C	30	28
Waste Rock Disposal area D	42	42
South Waste Rock Disposal	50	15
Mill and Administrative	26	4
Buildings		
ESI Heap Leach	8	8
Test Heap	10	0
Borrow Area	11	0
Roads	30	0
Tailings Disposal Area	192	0
<b>TOTAL AREA</b>	<b>547</b>	<b>159</b>

Backfilling pits is a visual and safety issue that receives a large amount of public attention. Although pit backfilling may not be the most important issue of

reclamation, the sheer magnitude of this commitment to land reclamation deserves recognition.

## **GROWTH MEDIUM**

Careful management of growth medium is essential to allow productive plant growth. During mine development, construction activities, and before each additional area is disturbed, available suitable growth medium material is stripped and stockpiled. Growth medium stockpiles are located along roads and near disturbance areas to provide easy access for reclamation. The growth medium stockpiles are graded and stabilized with slopes no greater than 2:1. Growth medium stockpiles are planted with a cover crop of western wheatgrass for stabilization.

The topsoil at the San Luis Mine has been identified as the A soil horizon only, it is shallow and most of the nutrients have been translocated downward into the subsoils (B soil horizon). The A soil horizon has the lowest runoff potential, it includes deep sands with very little silt or clay, and deep, highly permeable gravel. The B soil horizon has a moderately low runoff potential, it is mostly sandy soils less deep and less aggregated than A, and has an above average infiltration after thorough wetting. These observations were based on soil profile inspections by soil and vegetation expert, Dr. Sam Bamberg. Dr. Sam Bamberg also cautioned BMRI early against the use of the predominantly sandy soils below the B soil horizon as a suitable subsoil material. These soils would likely provide less water holding capacity and would not enhance the revegetation efforts. Given these site specific conditions, mixing of the topsoil and the subsoil has provided a better and superior quality growth medium than segregating the two or salvaging topsoil only. Also the clay fines that are generated in the breakdown of the waste rock have provided better moisture and nutrient holding capacities than the predominantly sandy subsoils.

During final reclamation, growth medium is placed at a depth of 8 to 12 inches on waste rock disposal areas and 12 to 18 inches on the east and west pits. Since the amount of growth medium available is plentiful these numbers tend to be higher rather than lower in actuality. The average rooting depth of the grassland species is 12 to 15 inches, thus, the depth of growth medium is sufficient in allowing the development of these species. Haul trucks bring in and end-dump the growth medium. Each haul truck can hold approximately 75 tons of growth medium. Dozers are used to spread the growth medium. Growth medium is placed on roughened surfaces to ensure good contact and is lightly compacted to allow for water retention and to prevent erosion.

Diversion structures have been installed adjacent to and downhill from growth medium stockpiles to divert stormwater away. This minimizes the amount of

stormwater coming in contact with the growth medium and reduces the possibility of erosion. However, revegetating growth medium stockpiles is a more effective and less impactful method of controlling sediment runoff.

## SEEDING

Seedbed preparation for areas to be revegetated takes place after grading, stabilization, and growth medium placement. Compacted surfaces are loosened and left in a rough condition. The prepared seedbeds are then seeded with the approved seed mixture and seeding rates are doubled when seeding is done by broadcasting.

Recommended seed mixtures and rates have been formulated based on known climatic and soil conditions of the project area. The average annual precipitation of about 15.25 inches is sufficient to support all present and proposed species. Grasses were chosen because it is believed that wildlife habitat can be improved by establishing a post mining community that is predominantly grassland. As evidenced by the ESI heap leach pad, the undisturbed areas are an excellent source of seeds and will result in the growth of sagebrush and piñon and juniper trees that are not included in the seed mixture.

The following species and rates are recommended for seeding on the site. This list has been checked with personnel at the U.S. Soil Conservation Service office in San Luis.

<u>Plant Species</u>	<u>Rate (lbs/acre)</u>
Western Wheatgrass	4
Mountain Brome	3
Blue Grama	2
Indian Ricegrass	2
Mountain Muhly	1
Cicer Milkvetch	1.5
Mountain Mahogany	0.5
Winterfat	0.5

Western wheatgrass is a cool season grass that is one of the most common and abundant wheatgrasses in the West. It is a long-lived and erect, sodformer. Western wheatgrass is a primary forage species on ranges of piñon woodlands. It produces forage early in the spring and it cures well on the ground providing good winter forage. Moderately palatable to livestock, bighorn sheep, deer, and elk and moderately drought resistant.

Mountain brome is also a cool season yet short-lived perennial bunchgrass native to the intermountain west, that requires plentiful amounts of water. It establishes quickly and easily on disturbed sites. Good palatability to livestock and elk especially when it is green. Performs well at high elevations.

Blue grama is a long-lived warm season grass. It is adapted to a broad spectrum of soils but thrives on medium textured, well-drained sites. It is the most drought resistant of major grasses and very resistant to grazing. It is highly palatable and nutritious all year long and is rated as the choice forage for livestock and wildlife.

Indian Ricegrass is a warm season grass and is highly palatable and nutritious for livestock and wildlife. It can be consumed all year long and supplies the most nutrition in the spring before other natives have begun much growing. It is one of the most drought resistant range grasses. The plants are short-lived and must produce seed if any quantity is to be maintained on-site. Excellent for rangeland improvement and land reclamation.

Mountain muhly is a warm season, perennial grass that grows in high elevations. It is a very important forage grass throughout ponderosa pine and piñon woodland areas.

Cicer milkvetch is a spreading, warm season, legume native to Eurasia but well adapted to the western United States. It can tolerate a wide range of soils. It is used for high elevation meadows, irrigated pastures, cover crop in orchards, windbreaks, and restoration of big game ranges. Useful for reclamation and erosion control. Slow to establish, but competitive over time, fair drought tolerance, and very resistant to cold weather.

Mountain mahogany is a bushy shrub/small tree and occurs on a wide range of either rocky or gravelly sites. It is strongly drought tolerant and palatable for deer, bighorn sheep, elk, and livestock. It provides cover for small birds and animals. It is a good soil stabilizer and windbreaker. Winterfat grows in such varied climates, for instance, Death Valley and high mountain ranges. It can grow from soils near alkaline to neutral calcareous and from clays to sandy loams. It is a very drought resistant shrub. Extremely palatable to livestock and wildlife.

## CONCLUSION

At the San Luis Mine we are successfully and concurrently reclaiming. BMRI is committed to sound environmental practices and successful rehabilitation of disturbed areas. Our goal to reclaim the land to an improved wildlife habitat has already begun to be realized. During operations we have been visited by many herds of elk and deer, a bighorn sheep, a bear, and numerous small mammals. It is obvious that the elk and deer enjoy the grasses (planted as part of our reclamation plan) especially when winter forage becomes increasingly scarce.



# Geology of the San Luis gold deposit, Costilla County, Colorado: an Example of Low-angle Normal Fault and Rift-related Mineralization in the Sangre de Cristo Range of Colorado

Robert G. Benson  
Colorado School of Mines  
Golden, Colorado 80401-1887

David M. Jones  
Paradex Exploration  
4901 East Sunrise, Suite 1808  
Tucson, Arizona 85718



## ABSTRACT

The San Luis deposit of Costilla County, Colorado, contained 11,021,000 tonnes (12,149,000 tons) of ore at 1.4 g/t (0.040 oz/st) gold in two minable zones. Gold mineralization is associated with silicification and quartz-sericite-pyrite hydrothermal alteration, localized in breccias in the lower-plate of a low-angle, normal/detachment fault zone. Gangue minerals include chlorite, specular hematite, chalcopryrite, chalcocite, and fluorite. Precambrian biotite-hornblende gneiss is the dominant rock type in the lower-plate of the detachment fault zone. Precambrian biotite-hornblende granitic gneiss is present in the upper plate of the detachment fault zone. Portions of the ore body are unconformably overlain by sedimentary rocks of the Tertiary Santa Fe Formation. The detachment-fault surface is commonly characterized by clay gouge of illitic to chloritic composition. Mineralization is mid-Tertiary in age and has a direct genetic relation to the emplacement of rhyolitic dikes and sills. The deposit formed during the early stages of extensional tectonism along the eastern edge of the present day Rio Grande rift. The deposit is similar to other mineralized areas of the Sangre de Cristo Mountains and is an excellent example of a rift and detachment-related gold deposit. Mining will be completed in 1997.

## INTRODUCTION

### Location

The San Luis deposit is located about 5 miles northeast of the town of San Luis in Costilla County, south-central Colorado, in the foothills of the Sangre de Cristo

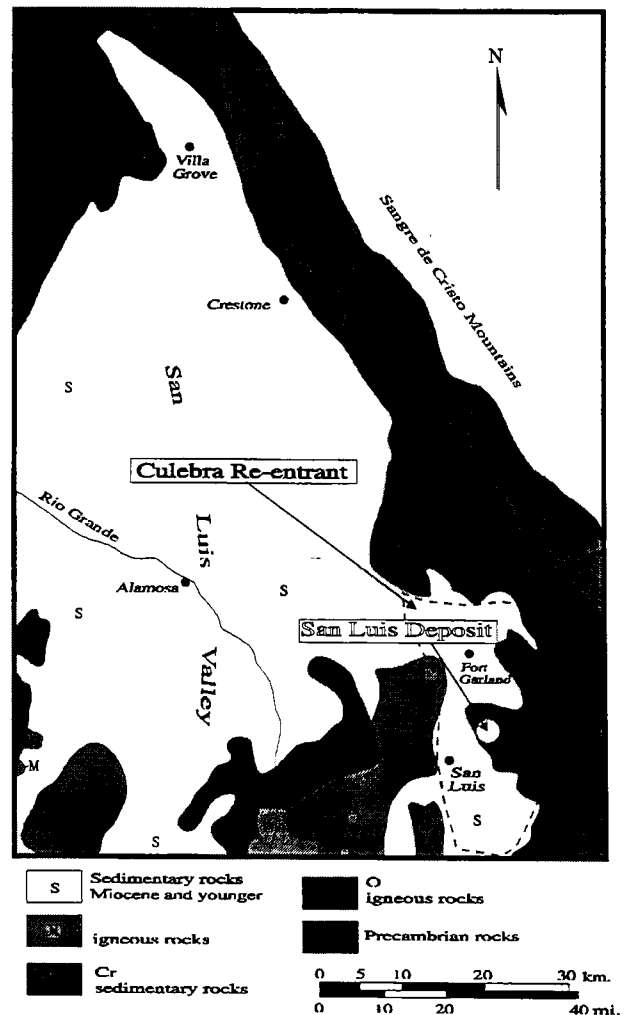

Figure 1. Location and geologic map of the San Luis Deposit area (modified from Keller, et al, 1984)

Mountains (Fig 1.). The deposit topography consists of gently- dipping southern to southwestern-facing slopes at elevations from 8200 ft. to over 9000 ft. The dominant vegetation is sagebrush, juniper, and piñon pine. Average rainfall at the mine site is 12" annually. The Rito Seco flows westward across the southern part of the deposit area.

North of the San Luis deposit adjacent to the west flank of the Sangre de Cristo Mountains are the towns of Fort Garland, Crestone, and Villa Grove, Colorado (Fig. 1). The large population center of Alamosa lies about 22 miles to the west. Historic mining districts and abandoned towns are also present along the western flank of the Sangre de Cristo Mountains north of the San Luis deposit (Ellis, et al., 1983; Johnson, et al., 1984; Scott, 1986; Ellis, 1988; Jones, 1991; Watkins, pers. comm.). The historic districts of Blanca, Liberty (Duncan), Crestone, and Orient (Villa Grove) represent some of the now-abandoned mining areas (Vanderwilt, 1947).

### **Historical activity and previous work**

The San Luis deposit lies within the historical Sangre de Cristo land grant which was deeded by the Mexican government in 1844 to persons of purported Spanish ancestry (Simmons, 1979). After the 1848 Treaty of Guadalupe Hidalgo, the U.S. Congress formally recognized the grant as a private inholding in the newly established New Mexico Territory.

First knowledge of gold mineralization at San Luis probably dates back to the late 16th or early 17th century when Spanish expeditions from Mexico went in search of the mythical golden cities of Cibola. The first recorded mining activity started in 1890 near what was recently mined as known as the East Ore Zone. Lead and silver were the principal metals mined and the presence of galena accounts for the historical name of "El Plomo" for the San Luis deposit. A gold mill with an amalgamation circuit and later a cyanide circuit operated intermittently from 1897 through 1934. The mill-feed material mostly came from an open cut immediately south of the East Ore Zone (Fig. 2).

The area of the San Luis deposit was first described by Gunther (1905). Benson and Jones (1990; 1994) described the geology of the San Luis deposit during exploration, development, and production phases. Benson and Jones (1990; 1994) have proposed detachment-fault controls on mineralization at the San Luis deposit. Kaina (1993) has described some of the mineralogical, alteration, and geochemical characteristics of the San Luis deposit.

Mineralization and historical mining activity within the Sangre de Cristo Mountains were evaluated by Ellis, et al, (1983), as part of the Sangre de Cristo Wilderness study. The geology of the Sange de Cristo Mountains is described by Johnson, et al (1984) as part of the same study. The U. S. Geological Survey is presently mapping quadrangles between Mount Blanca and the San

Luis Deposit (Wallace, pers. comm.). Kluth and Schaftenaar (1994) and Brister and Gries (1994) have recently addressed tectonic and basin development of the San Luis Valley.

The San Luis Deposit contained 11,021,500 tonnes (12,149,000 tons) of ore at 1.4 g/t (0.040 oz/st) of gold in two minable areas named the East Ore Zone and the West Ore Zone. The East Ore Zone contained 1,277,300 tonnes (1,408,000 tons) with a projected average grade of 1.68 g/t (.049 opt) of gold and lies in the extreme east portion of the mine property (Fig. 2). The West Ore Zone contained 9,744,000 tonnes (10,741, 000 tons) with a projected average grade of 1.34 g/t (.039 opt) of gold and lies in the central and western portion of the mine property (Fig. 2; Johnson, 1989).

### **GEOLOGIC SETTING**

The San Luis deposit is located in the Sangre de Cristo Mountains. The Sangre de Cristo Mountains are a northerly trending chain of 12,000- to 14,000-foot peaks which extend over 340 km from Santa Fe, New Mexico to Salida, Colorado. The San Luis deposit lies between 8200 to 9000 ft. of elevation along the west slope of the range at the east edge of the San Luis basin (Fig. 1). The bulk of the Sangre de Cristo range in the deposit area consists of 1,800 Ma Proterozoic gneisses which have been intruded by 1,700 and 1,400 Ma granitic rocks (Tweto, 1979). The eastern half of the range consists dominantly of Paleozoic sedimentary rocks which were steeply upturned and folded during Laramide orogenic events. Near Crestone, Colorado, the Paleozoic rocks extend westward across range into the San Luis Valley for short distance (Fig. 1; Johnson, et al, 1984). The Sangre de Cristo Mountains form the eastern side of the Rio Grande Rift in the San Luis Valley area and the west-facing slope is where most known mineral occurrences are found. A complex series of rift-related faults are present along the west-facing slope of the Sangre de Cristo Mountains, including high-angle normal faults and low-angle detachment faults (Tweto, 1979, McCalpin, 1982; Brister and Gries, 1994; Jones and Benson, 1994; Kluth and Schaftenaar, 1994; Wallace, 1995). The present relative uplift of the range is inferred to have occurred during Neogene and Quaternary time (Tweto, 1979).

Synchronous with Neogene uplift of the Sangre de Cristo range was the development of the San Luis basin and deposition into it of poorly-sorted, high-energy sediments of the Miocene to Pliocene Santa Fe Formation and the Pliocene to Quaternary Alamosa Formation. The northerly trending San Luis basin extends over 240 km from Taos N.M. to Poncha Pass, Colo., and is an integral part of the Rio Grande rift system. Estimated depths of basin fill in the San Luis area are on the order of several thousand meters (Keller and others, 1984, Brister and Gries, 1994; Kluth and Schaftenaar, 1994).

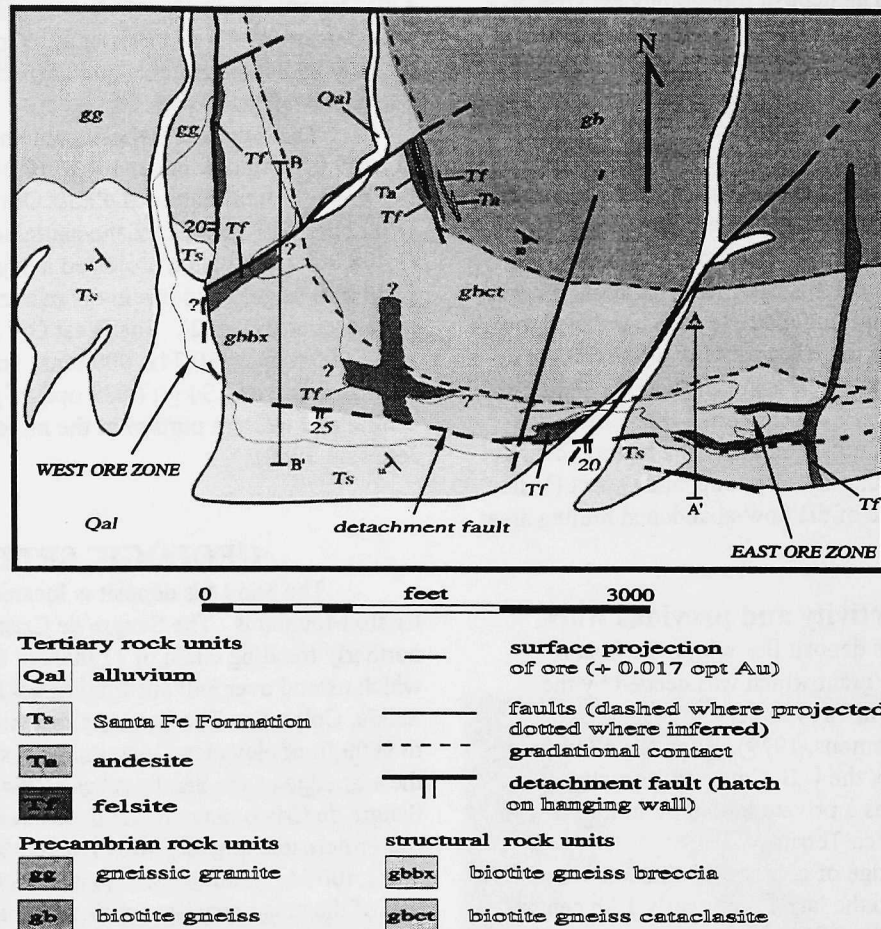

Figure 2. Generalized geology of the San Luis deposit area, based on mine mapping and Benson and Jones (1990, 1994). Tertiary and Precambrian rock units are grouped together. Structural rock units are derived from the Precambrian rock units. Fault clay is not shown here because the fault clay is typically less than 5 feet thick.

The San Luis deposit lies adjacent to a portion of the basin known as the Culebra reentrant (Fig. 1., Upson, 1939). Within the reentrant Santa Fe Formation is present and deeply eroded at elevations up to 10,000 ft. Elsewhere in the San Luis Valley basin, sediments of the Santa Fe lie at less than 8,000 ft elevation. It appears that the San Luis deposit lies within a portion of the Rio Grande rift where Tertiary sedimentary rocks are preserved at a higher structural level. Wallace (1995) has proposed a half-graben structural origin of the Culebra Re-entrant. Wallace (1995) also describes a complex mosaic of faulting within the Culebra Re-entrant.

No large Tertiary intrusions are exposed in the vicinity of the San Luis deposit. The nearest volumetrically significant intrusive centers are the 26-22 Ma Questa magmatic system to the south (Lipman and others, 1986), the 25-19 Ma Spanish Peaks system to the east (Tweto, 1979), and small sill-like intrusions near La Veta pass to the north. Oligocene andesitic lavas crop out in the study

area southeast of Mount Blanca and north of the San Luis deposit (Tweto, 1979). Rhyolite and andesite (?) dikes and sills are present at San Luis but nowhere do these exceed 10's of meters in thickness.

## GEOLOGY OF THE SAN LUIS DEPOSIT

Gold mineralization at San Luis occurs as tabular bodies within and below a low-angle detachment fault zone in cataclastically deformed Precambrian metamorphic rocks (Figs. 2, 3, 4). The major dislocation surface of the fault zone is preserved as unmineralized clay fault gouge which marks the upper extent of economic mineralization. Hangingwall to the fault zone are cataclastically deformed Precambrian metamorphic rocks and Tertiary-Quaternary sediments with minor interbedded volcanic flows. Higher gold grades in the deposit are closely associated with silicification and quartz-sericite-pyrite alterations that have destroyed the primary textures. Felsites are observed frequently within silicified areas adjacent to high-grade

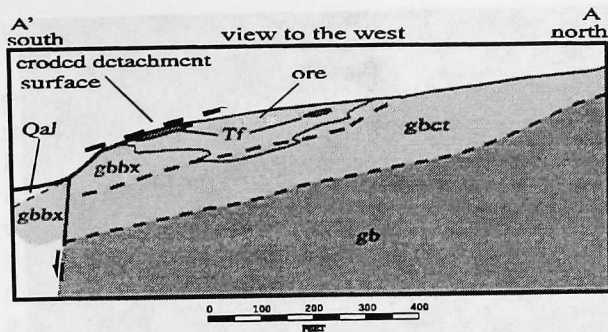

**Figure 3. Generalized cross-section of the East Ore Zone, view to the west. Rock unit descriptions can be found on Figure 2.**

gold mineralization. Peripheral areas are dominated by chlorite-carbonate and quartz-specular hematite alteration which carry low-grade to non-detectable gold values. Primary lithologies are discussed separately from structural or secondary lithologies.

### Primary lithologies

#### Precambrian rocks

The dominant lithologies at San Luis are Proterozoic biotite gneiss and gneissic granite. Biotite gneiss is an 1800 Ma (Tweto, 1979) gray quartz-feldspar-biotite gneiss. Biotite gneiss is the dominant rock type below the detachment fault zone (Figs. 3, 4). Structurally deformed and hydrothermally altered biotite gneiss is the host to gold mineralization. A typical modal composition is 25 to 35% feldspar, 20 to 25% quartz, and 5 to 10% biotite. The remaining percentage consists of variable amounts of hornblende, chlorite, sericite, magnetite, and specular hematite. Chlorite and minor magnetite are more abundant closer to and within cataclastically deformed gneiss. Gneissic foliations vary from E-W, 15° to 30°S in the East Ore Zone, to N-S, 15 to 30°W in the northwestern part of the West Ore Zone. Foliations in the biotite gneiss appear to be sub-parallel to the orientation of the detachment fault up to 80m below the clay zone. In localized areas within cataclastically deformed biotite gneiss, foliations are disrupted and rotated.

Gneissic granite is a 1700 Ma (Tweto, 1979) greenish-gray to reddish-gray quartz-orthoclase granite. Gneissic granite occurs in the hangingwall of the detachment fault zone and crops out in the northwestern part of the West Ore Zone (Figs. 3, 4). Gneissic granite is deeply weathered where exposed. Gneissic granite does not host gold mineralization. A typical modal composition is 30 to 35% orthoclase and 25% quartz. The remainder of

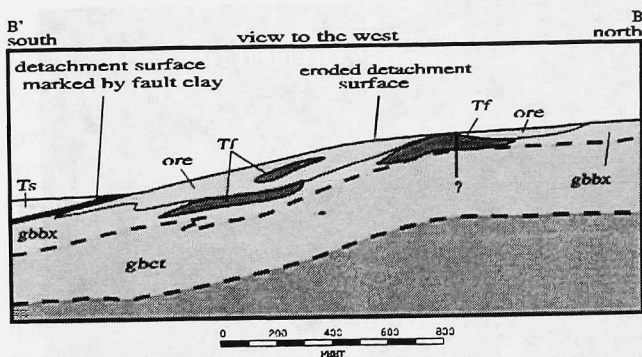

**Figure 4. Generalized cross-section of the West Ore Zone, view to the west. Rock unit descriptions can be found on Figure 2. Fault clay is shown slightly larger for clarity, and is not shown in Figure 2.**

the rock consists of muscovite, biotite, amphibole, chlorite, clay, sericite and iron oxides. Locally extensive pegmatites of potassium feldspar and quartz crosscut and are locally concordant with foliation. Books of biotite weathering to chlorite are common along pegmatite contacts. Foliations are irregular and do not show a relationship to the detachment fault zone orientation. Diabase dikes and irregular masses occur within the gneissic granite. These equigranular and magnetite-rich intrusions are inferred to be Precambrian in age.

#### Tertiary igneous rocks

Two Tertiary igneous rock types of volumetric significance are present in the San Luis deposit area: felsite sills and dikes, and andesite dikes and flows. Felsite occurrences are far more common.

Felsite is an aphanitic to weakly porphyritic pale-green to gray intrusive rhyolite. Felsite is the igneous rock type associated with mineralization. Intrusive contacts are commonly flow laminated. Felsite is usually distinguished from altered biotite gneiss breccia by the presence of  $\leq 2$ mm quartz and euhedral feldspar phenocrysts. Felsite can often be distinguished from associated silicified biotite gneiss breccia by more blocky and regular fracturing in the felsite.

Felsite sills and associated dikelets occur within the ore zones closely associated with mineralization. Sills are often difficult to distinguish from intense silicification and mineralization. Nowhere have felsites been observed cross-cutting the fault clay of the detachment surface.

Dikes trend north to north-northwest through the mine area. Dikes are typically pervasively sericitized, weakly to strongly silicified, and may contain trace fluorite and up to 1% disseminated pyrite. Dikes typically trend north-south and apparently crosscut all rock types below the detachment fault. Age dates on sericite concentrates from two felsites are  $24.0 \pm 1.0$  Ma and  $24.1 \pm 1.0$  Ma

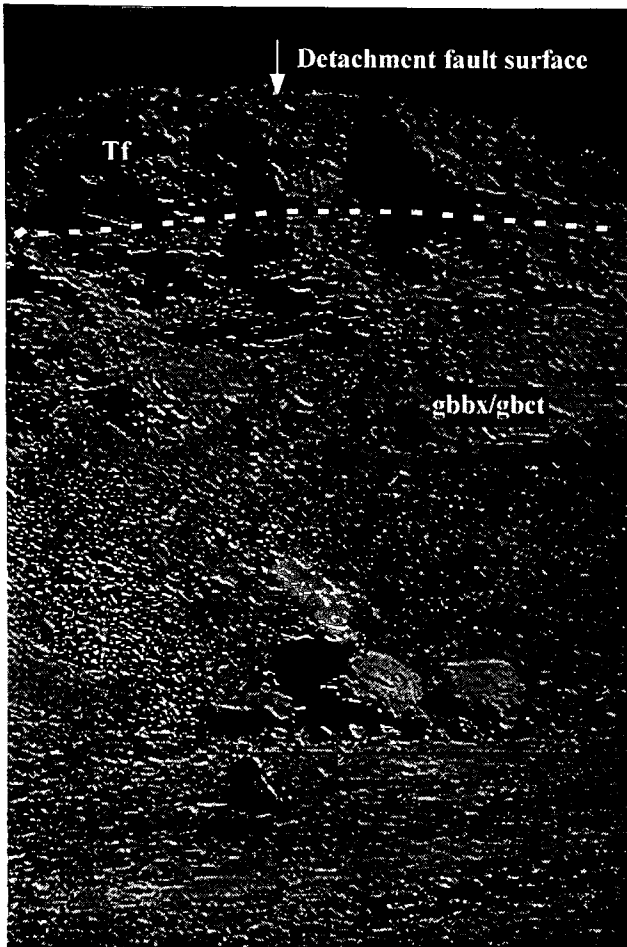

**Figure 5.** North -looking view of an outcrop of felsite sill above biotite gneiss breccia (gbbx) and biotite gneiss cataclasite (gbct). The contact is shown by the white dashed line. The top of the outcrop is a remnant of the detachment surface. Outcrop is about 30 ft. high, with pack in foreground for scale.

(K/Ar; Krueger Geochron Laboratories). The similar alteration of felsite and mineralized areas, and presence of felsite sills and dikelets directly within ore zones, strongly suggest a genetic relation of felsite to gold mineralization.

Andesite has been observed in flows and dikes. Andesite dikes contain pyroxene, plagioclase, biotite, hornblende, and magnetite. Dikes typically trend north-south and apparently crosscut all rock types below the detachment fault. Andesite dikes are not observed to crosscut the detachment fault surface. Andesite is believed to be younger than 24 Ma and is not associated with gold mineralization. Andesite flows occur in the southern part of the mine area, interbedded with Santa Fe Formation sediments, and are believed to be derived from the same source as the andesite dikes found north of the West Ore zone.

#### **Tertiary-Quaternary sedimentary rocks**

Tertiary Santa Fe Formation at the San Luis deposit consists of a repetitive flat-lying sequence of silts,

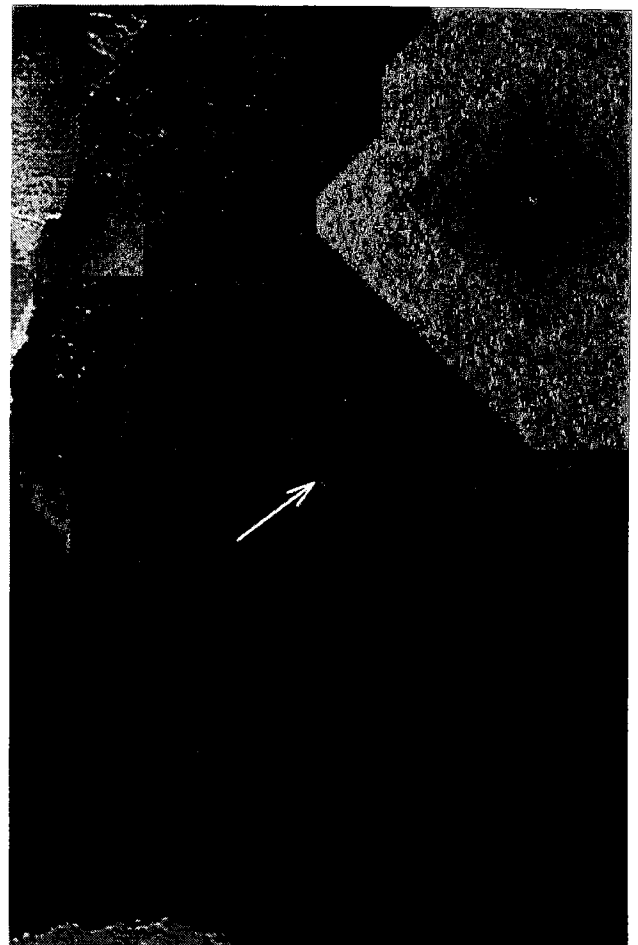

**Figure 6.** Example of Santa Fe Formation, showing poorly-sorted bedding and flat-lying beds. Outcrop is about 30 feet above fault clay in the detachment fault in the West Ore Zone. A six-inch scale lies at the tip of the arrow.

sands, gravels and cobble lenses. Santa Fe Formation unconformably overlies gneissic granite in the West Ore Zone. Santa Fe Formation unconformably overlies fault clay or biotite gneiss breccia in the East Ore Zone. Cobbles of gneissic granite are more abundant in the lower beds of the Santa Fe Formation.

Quaternary alluvium consists of channel-fill gravels and sands. A thin layer of alluvium is present over much of the deposit area, and is upwards of 20 ft. thick near the Rito Seco.

#### **Structural lithologies**

The detachment fault zone which hosts gold mineralization at San Luis is divided into three structural lithologic units: (1) fault clay, (2) biotite gneiss breccia, and (3) biotite gneiss cataclasite. Biotite gneiss breccia is the principal ore host, with lesser occurrences of ore in biotite gneiss cataclasite. The fault clay contains no mineralization.

## **Fault clay**

A fault clay zone separates hangingwall gneissic granite from underlying biotite gneiss. Fault clay mostly separates lower plate biotite gneiss breccia from Santa Fe Formation. In general, fault clay thins to the north and east when present under Santa Fe Formation. Fault clay marks the detachment fault zone. The clay averages 2 meters in thickness and probably formed through extreme grain size reduction of mostly overlying gneissic granite and some underlying biotite gneiss breccia during displacement along the detachment fault. In lower parts of the fault clay, fragments of biotite gneiss breccia or cataclasite can be found. Upper contacts of the fault clay with overlying gneissic granite or Santa Fe Formation can be very irregular. In the western part of the deposit area where the detachment fault underlies the gneissic granite/Santa Fe Formation contact, fragments of Santa Fe Formation have been incorporated in the upper parts of the fault clay. Clay color ranges from gray to gray-green to pale reddish brown. Fault clay has an illitic to chloritic composition. Glanzman (pers. comm) suggested a 1-m illite composition in at least one sample of fault clay. Concordant gypsum veinlets are locally present in the fault clay. These veinlets are subparallel to the detachment surface.

## **Biotite gneiss breccia**

Biotite gneiss breccia is the principal host to gold mineralization. The breccia consists of subangular to subrounded clasts ranging in size from <1 mm to 10's of mm, set in a fine-grained rock flour matrix. Clasts typically consist of quartz, with lesser amounts of feldspar. In thin section, strain textures are visible in quartz fragments. Biotite gneiss fragments and quartz-vein clasts are also present, but are less common. Clast size and abundance apparently decreases from the breccia-cataclasite contact up-section towards the fault clay zone. This is attributed to a general increase in the intensity of both structural deformation and alteration in this direction. Typically the breccia matrix is hydrothermally altered to an assemblage of quartz  $\pm$  sericite  $\pm$  pyrite (Romberger, written comm, 1989).

## **Biotite gneiss cataclasite**

Biotite gneiss cataclasite consists of subangular to subrounded rock fragments in a weakly-foliated, fine-grained fragmented matrix. The fine-grained matrix generally constitutes of less than five volume percent of the rock. Fragments show little or no rotation or disaggregation. Foliations in the cataclasite are more irregular and less evident than foliations in deeper, less deformed biotite gneiss.

## **Faults**

The principal structural feature of the San Luis Deposit is the detachment fault that separates gneissic granite from underlying biotite gneiss. In the southeast part of the West Ore Zone the detachment fault strikes east-west and dips 15° to 30° to the south (Figs. 2, 3). The fault changes to a more northerly strike, and dips 15° to 30° to the west in the northwest part of the West Ore Zone (Figs. 2, 4). The presence of brecciated, folded, and undisturbed quartz veins in outcrop indicates that faulting was at least in part syn-mineralization. Slickensided and distorted fracture and joint coatings of pyrite, and the presence of Santa Fe Formation in the fault clay also suggest syn-mineralization movement. Movement on the fault is inferred to be down-dip to the south and southwest. This is based upon interpretations of slickenside features, strikes and dips of hangingwall foliations, and asymmetrical folding in footwall rocks immediately below the detachment surface.

The deposit area is cross-cut by numerous northeast-southwest striking, steeply-dipping faults (Fig. 2). The East and West Ore Zones do not appear to have been significantly offset by post-mineralization fault movement. Mineralization in the West Ore Zone is partially cutoff on the north by a steeply-dipping, northeast-southwest striking fault. Mineralization in the East Ore Zone may be partially cutoff on the south by a steeply-dipping east-northeast striking fault. Faulting has had a local effect on ore body geometry. Inferred northerly-striking normal faults west of the deposit probably downdrop basement rocks and sediments to the west hundreds to thousands of meters and are likely rift-related.

## **Hydrothermal Alteration**

Four alteration assemblages are identified at San Luis in footwall rocks: (1) silica replacements/veins, (2) quartz-sericite-pyrite replacements/veins, (3) chlorite-carbonate replacements/veins, and (4) quartz-specular hematite veins. The most intense alteration is silica replacement/veining which is commonly associated with high-grade gold mineralization immediately beneath the clay zone. Silicification typically grades into quartz-sericite-pyrite alteration. The least intense hydrothermal alteration is chlorite-carbonate replacement/veining.

The overall hydrothermal alteration mineral distribution appears to be both lateral and downsection. The most intense silicification appears immediately below the fault clay that marks the detachment surface. Fault clay has not been silicified. Laterally and down-section, quartz-sericite-pyrite alteration becomes more intense. Further down-section and laterally, chlorite-carbonate alteration becomes the dominant alteration type. Specular hematite veins and replacements are frequently seen associated with quartz-sericite-pyrite alteration and are associated with chloritic alteration.

### **Silica replacements/veins (Silicification)**

Silica replacement and veining occur as pervasive matrix replacement of biotite gneiss breccia. Breccia fragments show partial resorption in silicified areas in thin-section. Quartz veinlets and minor replacements occur locally in biotite gneiss cataclasite, but are weakly mineralized. Silica ranges in color from dark to light gray. Dark gray silica contains  $\leq 3\%$  fine-grained disseminated pyrite. Very high gold grades are associated with dark gray silicification. Silicification is most intense immediately below the fault clay in the West Ore Zone. Dark gray silicification grades laterally and downward into lighter gray silicification and quartz-sericite-pyrite alteration. Replacement silicification is commonly cross-cut by quartz-veinlets and felsite sills. Cross-cutting relations are inconsistent. The inconsistency of cross-cutting relations suggests a single hydrothermal event of numerous sub-events.

### **Quartz-sericite-pyrite replacements/veins**

Quartz-sericite-pyrite alteration occurs as an intense gray-green matrix replacement of biotite gneiss breccia. Quartz veinlets commonly cross-cut the altered matrix. Pyrite associated with quartz-sericite-pyrite alteration is generally localized in clots and veinlets and is less commonly disseminated. Quartz-sericite-pyrite alteration grades upward into dark gray silicification and downward into chlorite-carbonate alteration. Quartz-sericite-pyrite alteration is distinguished from felsite by the absence of faint feldspar and quartz phenocrysts. Gold mineralization is associated with quartz-sericite-pyrite alteration but is not as intense as in the dark-gray silicification. Quartz-sericite-pyrite alteration crops out in the East Ore Zone.

### **Chlorite-carbonate veins**

Chlorite-carbonate alteration is relatively widespread and includes an overall less intense alteration assemblage of chlorite  $\pm$  carbonate  $\pm$  magnetite  $\pm$  clay  $\pm$  pyrite. Chlorite commonly occurs as a foliation replacement in biotite gneiss cataclasite and biotite gneiss. Chlorite is commonly found as a joint and fracture coating throughout the deposit, but is the result of shearing. In thin section, primary quartz, microcline, and plagioclase are partially replaced by fine-grained clay, sericite, and carbonate, and biotite is replaced by chlorite  $\pm$  magnetite (Romberger, written comm., 1989).

### **Specular hematite veins, replacements, and fracture coatings**

Specular hematite veins, replacements, and fracture coatings may have formed early along the detachment fault zone. Specular hematite is abundant peripheral to the deposit but appears to have been overprinted by more intense silica-sericite events in the

core of the deposit. Specular hematite may have been remobilized during hydrothermal alteration. Gold is not associated with specular hematite alteration.

### **Mineralization**

Mineralization is present in hydrothermally altered zones in biotite gneiss breccia and to a very minor extent in biotite gneiss cataclasite. Gold mineralization correlates with silicification and sulfide content. The dominant sulfide present is pyrite, in three polymorphs, with minor occurrences of chalcopyrite, molybdenite, galena, and possible acanthite (Suthard, 1988). Chalcocite is present in locally high concentrations associated with quartz veins and veinlets. The average gold to silver ratio is 1:2.5. Specular hematite and chlorite are usually found in more weakly mineralized areas and are associated with less intense hydrothermal alteration. Fluorite is commonly present in narrow quartz-fluorite veinlets and in open-space fillings. Fluid inclusion studies (Kaina, 1993) suggest hydrothermal fluids ranging in temperature from 200 to 280°C and 0 to 12 eq. wt% NaCl were responsible for mineralization. Kaina (1993) also suggests mixing of magmatic and meteoric water, based on N<sub>2</sub>, He, and Ar gas analysis. Gold may have been transported as bisulfide complexes (Kaina, 1993).

Three forms of pyrite are present in mineralized zones. Two appear to have no consistent association with ore-grade gold mineralization. Euhedral, untarnished, relatively coarse-grained pyrite has little correlation with gold mineralization. Untarnished, poorly-twinned pyritohedrons also have little or no correlation with gold mineralization. Irregular fine-grained clots of tarnished pyrite appear to have the most consistent correlation with gold mineralization.

Ore microscopy studies of sulfide concentrates indicate the presence, in order of decreasing abundance, of pyrite, chalcopyrite, hematite, goethite, anatase, galena, molybdenite, covellite, gold, and pyrrhotite (Deakin and Lehman, 1988). Gold is present along fractures in pyrite grains, as small blebs within pyrite grains, and as discrete particles. Gold grain size ranges from 2 to 160 microns, averaging 20 microns.

Q-mode factor analysis was applied to multi-element whole rock data from 85 drill hole intercepts in the West Ore Zone (Jones, 1989). Gold mineralization factors suggest a correlation of gold with silver, lead, copper, molybdenum, and fluorine. These correlations indicate that gold deposition at San Luis was part of a polymetallic mineralizing event. Gold also correlates with both iron-rich and iron-poor factors reflecting an inconsistent association with pyrite.

## East Ore Zone

The East Ore Zone strikes east-west and dips 15° to 25° to the south (Fig. 3). Ore was mostly confined to biotite gneiss breccia with minor mineralization occurring below in biotite gneiss cataclasite. The dominant alteration is intense quartz-sericite-pyrite alteration of biotite gneiss breccia. Silicification is intense but less so than in the West Ore Zone. Sulfides occur in clots and pods more than in disseminations. Breccia clast size generally decreases up section from the lower parts of the biotite gneiss breccia towards the fault clay zone. Biotite gneiss breccia zones range in thickness from 0 to 30 meters, averaging 15 meters. In the more intensely quartz-sericite altered breccias, clasts constitute less than 10% of the rock. The clay zone is present in irregular cappings throughout the East Ore Zone area, and is inferred to have capped the deposit prior to erosion. Asymmetrical folding immediately below the fault clay in hydrothermally-altered biotite gneiss breccia suggests normal movement along the low-angle fault. Numerous felsite sills and dikelets were exposed during mining. The felsite sills average 1 meter in thickness and generally show a close spatial relationship with mineralization. Felsite sills were often weakly mineralized. Felsite dikelets were also observed crosscutting mineralization at irregular intervals in the general area of felsite sills.

## West Ore Zone

The strike and dip of the West Ore Zone is roughly conformable to that of the host fault breccia (Fig. 4). As the strike of the fault changes from nearly east-west in the southern portion of the West Ore Zone to north-south in the northern portion of the zone (Fig. 2) so does the strike of the ore zone. The West Ore Zone dips 15° to 30° degrees to the south in the southern portion of the zone and 15° to 30° degrees to the west in the northern portion of the zone. Breccia clasts are typically <1 cm and make up upwards of 15% of the rock volume. Breccia thickness ranges from 0 to 45 meters, averaging 30 meters. The hangingwall of the West Ore Zone is Santa Fe Formation and gneissic granite (Fig. 4). The thickness of the gneissic granite section decreases from north to south. Biotite gneiss breccia appears to decrease in thickness to the north along strike of the detachment fault.

The West Ore Zone is mostly confined to intensely silicified and sericitized biotite gneiss breccia. Biotite gneiss cataclasite contains minor ore occurrences. Pyrite content varies from trace to 5%. The highest gold grades of the deposit are within the West Ore Zone in dark gray, pyritic silicification directly below the fault clay zone. The most intense silicification of the deposit is within the West Ore Zone where primary breccia textures are overprinted and destroyed by silica replacement and veining. Felsite sills are found closely associated with ore in the West Ore Zone. Felsite sills are often mineralized. Felsite dikelets

are also observed crosscutting mineralization at irregular intervals in the general area of felsite sills.

## SIMILAR MINERALIZATION IN THE SANGRE DE CRISTO RANGE

Mineralization is known in the Sangre de Cristo Mountains north of the San Luis deposit (Fig 1; Ellis, et al., 1983; Johnson, et al., 1984; Scott, 1986; Ellis, 1988; Watkins, pers. comm.). Lexam Explorations (USA), Inc., has conducted extensive gold exploration work near Crestone, Colorado, and is presently developing an oil resource in the same area (Watkins, pers. comm.). The U. S. Geological Survey is presently mapping quadrangles between Mount Blanca and the San Luis Deposit (Wallace, pers. comm.). Similarities to the San Luis deposit are present in many of the mineralized areas of the Sangre de Cristo Mountains, but are undergoing further study.

The west side of the Sangre de Cristo Mountain Range is bounded by a complex series of rift-related faults, including high-angle normal faults (Tweto, 1979, Brister and Gries, 1994; Kluth and Schaftenaar, 1994; Wallace, 1995) and low-angle detachment faults (Jones and Benson, 1994). McCalpin (1982) mapped a low-angle normal fault in underground workings in the Wild Cherry Creek area north of Crestone. Balleweg (pers. comm) described possible low-angle structures that may have affected mineralization in the Orient Mine near Villa Grove, Colorado. Watkins (pers. comm) described features similar to the San Luis deposit near Crestone, Colorado. Detachment faulting is believed to be a significant control on mineralization on the western flank of the Sangre de Cristo Mountains (Jones and Benson, 1994). Low-angle breccia zones and associated lithologies, felsic intrusions, mineralization and hydrothermal alteration patterns similar to those found at the San Luis deposit are found through the mineralized parts of the Sangre de Cristo Mountains.

## DISCUSSION

The San Luis deposit developed as part of a silicification/quartz-sericite-pyrite alteration event hosted by a low-angle detachment fault zone. Mineralization is polymetallic with gold deposition closely associated with silver, copper, and fluorine locally. Textural evidence clearly indicates that a major episode of faulting predated alteration and mineralization. A simple genetic model of the deposit can be derived from a discussion of the origin of the fault zone and the origin of the subsequent hydrothermal system. The genetic model may also provide insights on mineralization in the rift environment of the Sangre de Cristo Mountains. Areas of further work are discussed.

## Origin of the fault zone

In Laramide time the area of the present day Sangre de Cristo range underwent strong compressional deformation which resulted in thrust faulting and attendant folding in Precambrian and Paleozoic stratigraphies (Tweto, 1979). More recent Neogene extensional normal faulting has dissected this Laramide uplift. On the basis of this geologic history, the fault zone at San Luis has most commonly been interpreted as a thrust fault. The most recent movement on the low-angle fault zone is considered to be normal. The evidence for movement is based on field observations within the deposit area.

Arguments for detachment-style faulting at the San Luis deposit are based upon local and regional observations. The most important of these arguments are: (1) the preservation of the fault clay zone at its contact with the Santa Fe Formation; (2) the location of the fault zone at the edge of Neogene depositional basins; (3) asymmetrical fold features in biotite gneiss breccia immediately below the fault clay, and (4) the evidence that faulting was in part synchronous with emplacement of felsite intrusions.

The fault clay zone always separates hangingwall gneissic granite from footwall biotite gneiss. In several core holes and in mining exposures, Precambrian hangingwall rocks are not present and the fault clay is in direct contact with Santa Fe Formation. If the Santa Fe Formation was deposited on an eroded Laramide thrust fault surface, the clay zone would have been rapidly removed long before sedimentation. Clay zone preservation could only occur if it were immediately buried by unconsolidated Santa Fe sediments upon removal of the overlying Precambrian plate. This constrains major movement of the upper plate as synchronous with development of Santa Fe depositional basins, a Neogene event.

The fault zone at San Luis marks the east edge of the San Luis basin. The proximity of this fault to the edge of the basin implies that it is a Neogene basin bounding structure as opposed to an eroded or reactivated Laramide thrust fault.

Asymmetrical folds are present in the biotite gneiss breccia below the fault clay that marks the detachment surface. The folds are slightly steeper on the downdip limbs, suggesting a normal shear-sense and displacement.

Emplacement of mid-Tertiary felsite sills and dikes at the east edge of the San Luis basin is apparently synchronous with low-angle faulting.

We believe that local and regional geologic evidence indicate a mid-Tertiary extensional detachment origin for the fault zone at San Luis. Alteration and mineralization overprinting on cataclastic textures indicate that ore deposition was post-faulting, but there is evidence for at least minor post-mineralization faulting as well. Post-mineralization movement is suggested by deformed pyrite

and relatively unaltered fault clay immediately above intense hydrothermal alteration.

## Origin of mineralization/alteration

The origin of the mineralizing fluids responsible for the San Luis deposit is not well understood at present. Age determinations (K/Ar) of sericite-altered felsite dikes at the deposit yield  $\sim 24 \pm 1$  Ma. Felsite intrusions are commonly associated directly with ore. These age dates, felsite spatial relations to ore, and the association of gold with base metals and fluorine, lead us to conclude that mineralization has a genetic relation to mid-Tertiary magmatism associated with rifting.

## Genetic model

In the area of the San Luis deposit, low-angle detachment-style faulting developed in the middle Tertiary in response to an elevated geothermal gradient along the Rio Grande rift zone. Detachment faulting may have reactivated older thrust faults. Small-volume felsic magmas were emplaced at shallow crustal levels at this time. Magmatic metalliferous fluids intersected the low-angle fault zone at San Luis and precipitated sulfides in the relatively low-pressure, low-temperature environment of the breccias. Syn- and/or post-mineralization movement along the fault zone allowed for partial unroofing of the clay zone, which was immediately buried by unconsolidated Santa Fe sediments. Erosion of the Santa Fe Formation in the structurally elevated, "failed" portion of the rift basin allowed for partial exposure of the deposit.

Other areas of mineralization throughout the Sangre de Cristo Mountains show similar features to the San Luis deposit, but show some differences. As such, a San Luis genetic model cannot be directly applied to the Sangre de Cristo Mountains as a whole. However, the similarities observed in the field in many mineralized areas outside of San Luis strongly suggest a comparable genesis.

## Further work

Further work to constrain the geology of the San Luis deposit and the similarities of other mineralized areas in the Sangre de Cristo Mountains is ongoing as part of the senior author's PhD thesis. Additional petrographic and geochemical studies are being done to evaluate the nature of the detachment fault zone at San Luis and the other areas mentioned previously. Additional age determinations are being done on felsite intrusions associated with mineralization. Additional mapping to complement previous work is also ongoing.

## ACKNOWLEDGEMENTS

Many, many people have contributed to the current understanding of the San Luis deposit and similar

mineralization in the Sangre de Cristo Mountains. We would particularly like to thank all the past and present geologists of the Battle Mountain Exploration Company and Battle Mountain Gold Company for their comments and assistance, including F. Deakin, W. Lehman, V. DeRuyter, J. Suthard, and L. Vega. Tom Watkins and Jim Donalson of Lexam Explorations, Alan Wallace of the USGS, Sam Romberger, Graham Closs and Greg Holden of the Colorado School of Mines, have all provided us with valuable insights, stimulating ideas and discussions. However, we accept full responsibility for the ideas presented in this paper. We would also like to thank Dan Robertson of the Battle Mountain Gold Company for permission to publish information on the San Luis deposit.

## REFERENCES

- Benson, R. G., and D. M. Jones, 1990, Geology of the San Luis Deposit, Costilla County, Colorado, *in* Gold '90, D. Hausen, ed., AIME
- Benson, R. G., and Jones, D. M., 1994, Geology of the San Luis Gold Deposit, New Developments, Costilla County, Colorado, SME Preprint 94-100, 9 p.
- Brister, B. S., and Gries, R. R., 1994, Tertiary Stratigraphy and Tectonic Development of the Alamosa Basin (Northern San Luis Basin), Rio Grande Rift, South-central Colorado, *in* Basins of the Rio Grande Rift: Structure, Stratigraphy, and Tectonic Setting, Geological Society of America Special Paper 291, p. 39-58
- Deakin, F. A., and W. C. Lehman, 1988, San Luis Project, Costilla County, Colorado, Final Exploration Report, unpublished company report
- Ellis, C. E., Hannigan, B. J., and Thompson, J. R., 1983, Mineral Investigation of the Sangre de Cristo Wilderness Study Area, Alamosa, Custer, Fremont, Huerfano, and Saquache Counties, Colorado, U. S. Bureau of Mines Open-File Report MLA 65-83, 190 p., 2 maps
- Ellis, C. E., 1988, Mineralogy and Configuration of the Courthouse Vein System, Alamosa, Costilla, and Huerfano Counties, Colorado, as Related to Metal Recovery and Resource Continuity, 35 p.
- Glanzman, R. W., 1989, oral communications, Colorado School of Mines
- Gunther, C. G., 1905, The Gold Deposits of Plomo, San Luis Park, Colorado, *Economic Geology*, Vol. 1, No. 2, p. 143 - 154
- Johnson, B. R., Lindsey, D. A., Ellis, C. E., Hannigan, B. J., and Thompson, J. R., 1984, Mineral Resource Potential for the Sangre de Cristo Wilderness study Area, south-central Colorado, U. S. Geological Survey Miscellaneous Field Studies Map MF 635-A, pamphlet, 13 p., 2 maps
- Johnson, S. D., 1988, San Luis Project, Minable Reserve Calculation Procedure and Results, unpublished company report
- Jones, D. M., 1989, Application of Extended Q-Mode Factor Analysis to the Geochemistry of Selected Drill Hole Intercepts of the San Luis Gold Deposit, Colorado, unpublished company report
- Jones, D. M., 1991, Low-angle normal faulting and gold mineralization in the Sangre de Cristo Range of southern Colorado, *Geological Society of America Abstracts with Programs*, v. 25, p. A246
- Jones, D. M., and Benson, R. G., 1994, Low-angle Normal Faulting and Controls on Precious and Base-metal Mineralization in the Sangre de Cristo Range of Colorado and New Mexico: The "Detachment" Origin of the Northern Rio Grande Rift, abstract, *Tectonics in Mineral Exploration*, SME-AIME 1994 Annual Meeting, Albuquerque, New Mexico
- Kaina, A., 1993, Mineralogy, Alteration, and Geochemical Studies of the San Luis Gold Deposit, Costilla County, Colorado, unpublished Master's Thesis, New Mexico Institute of Mining and Technology, Socorro, New Mexico, 77 p.
- Keller, G.R., Cordell, L., Davis, G.H., Peeples, W.J., and White, G., 1984, A Geophysical Study of the San Luis basin: *in* New Mexico Geological Society Guidebook, 35th Field Conference, Rio Grande Rift: Northern New Mexico, pp.51-57.
- Kluth, C. F., and Schaftenaar, C. H., 1994, Depth and Geometry of the Northern Rio Grande Rift in the San Luis Basin, south-central Colorado, *in* Basins of the Rio Grande Rift: Structure, Stratigraphy, and Tectonic Setting, Geological Society of America Special Paper 291, p. 27-38

- Lipman, P.W., Menhert, H.H., and Naeser, C.W., 1986, Evolution of the Latir volcanic field, northern New Mexico, and its relation to the Rio Grande Rift, as indicated by potassium-argon dating: *Journal of Geophysical Research*, v.91, no.B6, p.6329-6345.
- McCalpin, J. P., 1982, Quaternary Geology and Neotectonics of the West Flank of the Northern Sangre de Cristo Mountains, South-Central Colorado, *Colorado School of Mines Quarterly*, Vol. 77, No. 3, 97 p.
- Romberger, S. B., 1989, written report on thin sections to the Battle Mountain Gold Company
- Scott, D. C., 1986, Gold, Silver, and Tungsten Resources of the Courthouse Vein System, Sangre de Cristo Wilderness Study Area, Alamosa and Huerfano Counties, Colorado, U. S. Bureau of Mines Open File Report MLA 52-86, 28 p.
- Simmons, V.M., 1979, *The San Luis Valley*, Pruett Publishing Co., Boulder, Colo., 193 pp.
- Suthard, J. A., 1988, Silica Vein Study, unpublished company report
- Tweto, O., 1979, The Rio Grande rift system in Colorado: in Riecker, R.E. (ed.), *Rio Grande rift - tectonics and magmatism*: American Geophysical Union, Washington, D.C., pp.35-56.
- Upson, J.E., 1939, Physiographic subdivisions of the San Luis Valley, southern Colorado: *Journal of Geology*, v.47, pp.721-736
- Vanderwilt, J. W., 1947, *Mineral Resources of Colorado*, State of Colorado Mineral Resources Board, Denver, 547 p.
- Wallace, A. R., 1995 Cenozoic rift-related sedimentation and faulting, northern Culebra Range, southern Colorado, *in New Mexico Geological Society Guidebook, 46th Field Conference, Geology of the Santa Fe Region*



# Effect of Mining on Water Quality in the Red River, Taos County, New Mexico



Daniel J. Plazak  
Consulting Hydrogeologist  
4592 Everett Street  
Wheat Ridge, CO 80033

The Red River drains 190 square miles of the Sangre de Cristo Mountains, and empties into the Rio Grande twenty miles south of the Colorado border. The drainage exhibits some of the challenges to water quality in Rocky Mountain streams: naturally high dissolved metals, old abandoned mines whose practices were unregulated, current mines operating under modern environmental controls, and human waste from increasing tourism and population.

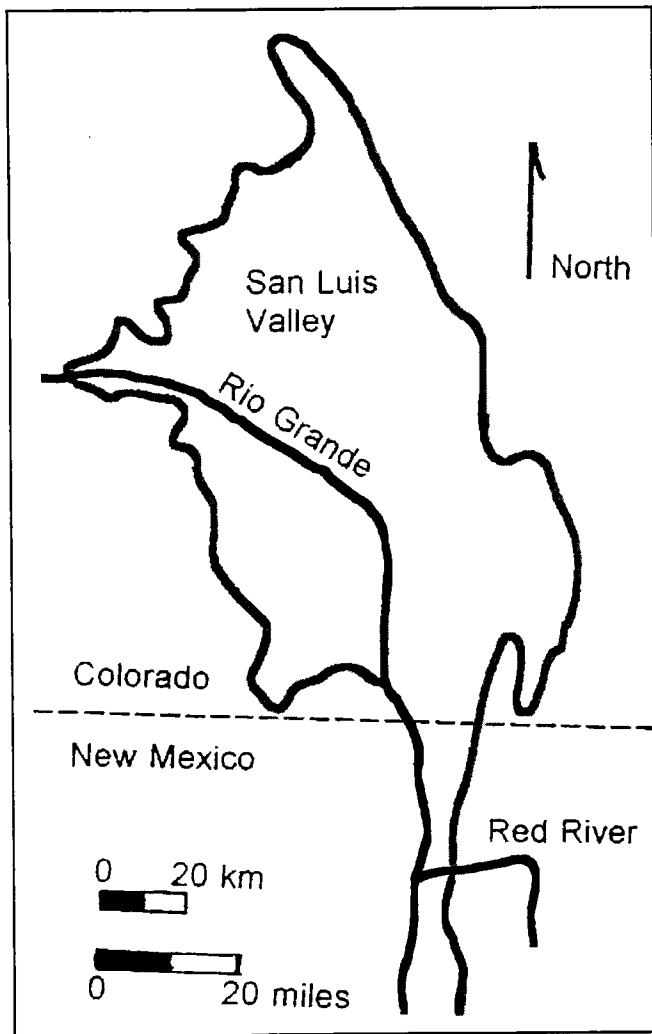

## AREA GEOLOGY AND NATURAL METALS POLLUTION

The Sangre de Cristo mountains in the Red River drainage have geology similar to other mineral-rich areas in Colorado and northern New Mexico. Precambrian metamorphic rocks (amphibolite, schist, and quartzite) and granite are partly covered and intruded by Oligocene to Miocene intrusive and extrusive rocks, including andesite, quartz latite, quartz monzonite porphyry, and rhyolite. Caldera collapse followed the volcanic activity.

The drainage contains numerous "hydrothermal scars" where intensely altered rock does not support vegetation. Disseminated pyrite and chalcopyrite in the hydrothermally altered areas contribute natural acidic and metal-rich runoff to the drainage. Steep topography and high erosion rates of the hydrothermally altered rocks increase the natural contribution of dissolved and particulate metals, including manganese and aluminum.

Reed (1922) noted several small streams rich in dissolved copper, and one spring in Alum Gulch whose flow was so high in dissolved copper that some miners tried to commercially recover the copper by directing the flow over scrap iron.

The name Alum Gulch suggests naturally acidic runoff, as does Bitter Creek, which empties into the Red River at the town of Red River. The name game should be played with caution, however, as the Rio Grande canyon west of Questa has Big Arsenic Springs and Little Arsenic Springs, both with good-quality water; the names were the discouraging words of an early settler who didn't want neighbors.

## MINING IN THE UPPER RED RIVER DRAINAGE

Although local tradition credits Spaniards with mining along the Red River at an early date, the first documented mining took place in 1867. The most active period was from 1893 to 1904 (Schilling 1960). Prospectors first searched the area for placer gold, then for hard rock sulfide deposits bearing gold, silver, lead, and copper.

At least nine mills on the Red River and its tributaries treated ore by mercury amalgamation or cyanide leaching. A copper smelter operated very briefly at the town of Red

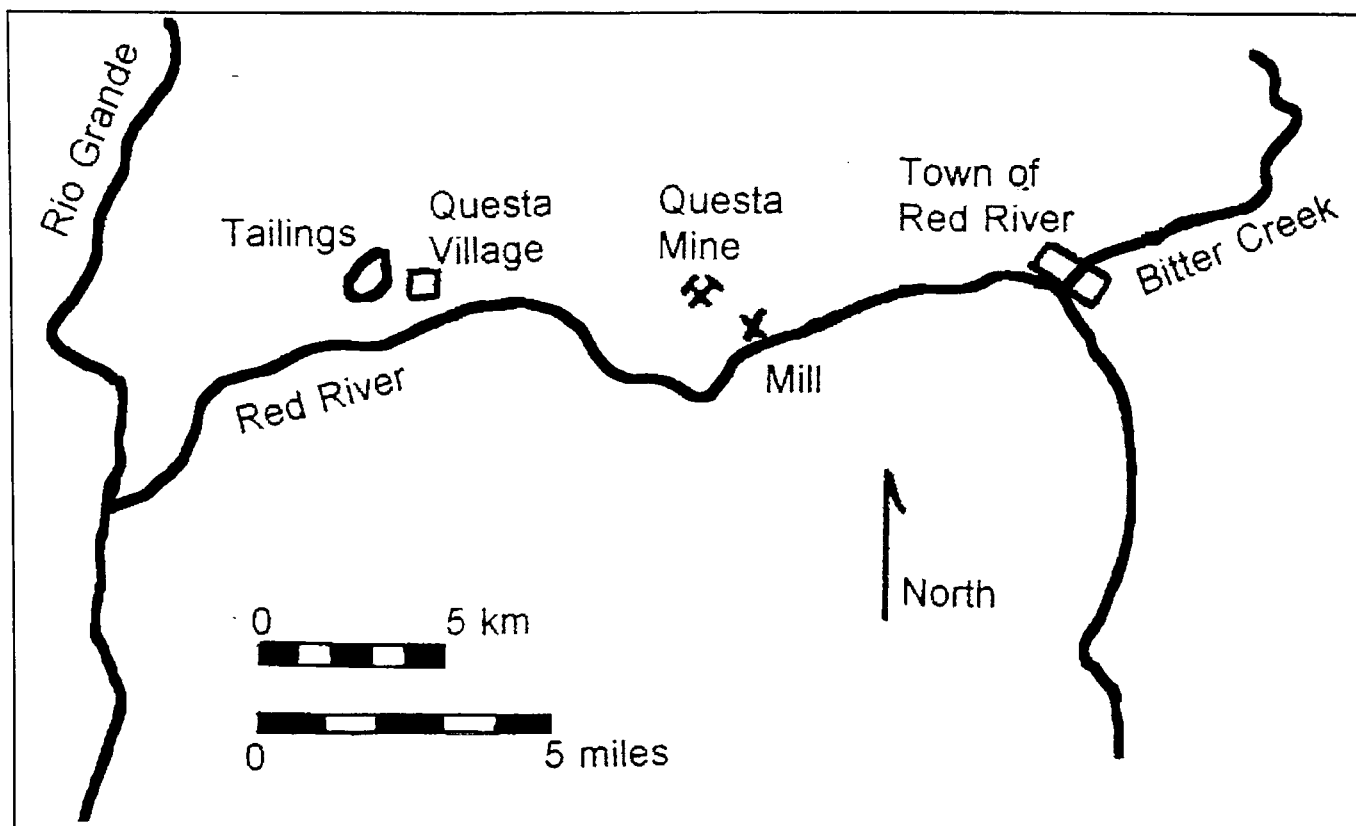

River. Controls on mercury and cyanide releases were often poor in turn-of-the-century mill operations, and tailings were typically discharged directly into the adjacent water course.

Most of the mining and milling was in the Bitter Creek Drainage. Although there are dozens of shafts and adits, some extending hundreds of feet, actual recorded metal production was very small. No mines are currently active in the upper Red River drainage.

### ACIDITY AND DISSOLVED METALS ABOVE THE QUESTA MILL

While the effects on water quality of natural degradation and abandoned mines are difficult to separate, intensive studies of water quality between Red River and the Questa molybdenum mill suggest that springs and thunderstorm runoff from hydrothermal scars contribute most of the sulfate and aluminum in that part of the Red River (Smolka and Tague 1989). The river above the Questa mill has elevated levels of dissolved sulfate, manganese, molybdenum and zinc (Garn 1985).

Some tributaries are acidic, but the Red River itself is usually neutral to slightly alkaline. The pH of thirty U.S. Geological Survey water samples collected over time from the Red River slightly above the Questa molybdenum plant varied between 7.2 and 8.4 (Garrabrant 1993). However,

thunderstorm runoff in small tributaries can have pH as low as 3.3, which can temporarily lower pH in parts of the Red River (Smolka and Jacobi 1986).

Metals dissolved in acidic tributary flow tend to precipitate in the higher pH of the River. Aluminum hydroxide precipitate, primarily from natural acidic sources, degrades the river habitat between Red River and Questa by cementing the bottom gravel.

### QUESTA MOLYBDENUM MINE AND MILL

On the north side of the Red River, downstream from the turn-of-the-century mining and milling activity, Molycorp Inc. operates the Questa mine and mill, historically a major primary molybdenum producer.

The Questa deposit was discovered in 1916. Underground mining began on a small scale in 1919, treating the ore at the June Bug Mill, a former precious metals mill near the town of Red River (Schilling 1960). A mill specifically built to treat the molybdenum ore was erected at the present plant site in 1923, with the tailings placed in small impoundments near the plant. The start of large-scale open pit mining in 1964 created the need for a larger tailings disposal area than could fit in Red River canyon, so Molycorp built an 8-mile pipeline along the river to carry tailings slurry from the mill to tailings

impoundments northwest of the village of Questa.

Molycorp stopped working the open pit in August 1981 and renovated the mill to receive ore from a new underground mine on the property. Due to low molybdenum prices, the underground mine did not begin until August 1983, and the updated mill restarted in October 1983. Low molybdenum prices caused the mine and mill to again shut down at the end of February 1986. The operation remained dormant until mining resumed in late 1989. The mine closed once more in January 1992, and remained so until dewatering operations began in 1995 in response to higher molybdenum prices.

By the early 1980s, Molycorp began looking ahead for more tailings areas, and applied for permits to build a new impoundment in a large saddle on Guadalupe mountain northwest of Questa. The federal Bureau of Land Management first approved the plan, then rescinded its approval and required Molycorp to investigate other alternatives. In the meantime, Molycorp is raising the heights of its existing impoundments.

The Questa mill, which discharges through the tailings impoundment downstream from the village of Questa, has historically raised the levels of dissolved molybdenum, sulfate, and cyanide in the Red River below the outfall. The water quality of the mill discharge complies with the limits imposed by the National Pollution Discharge Elimination System (NPDES) permit. Elevated sulfate and aluminum values in the Red River adjacent to the Molycorp mine and mill area have historically been considered to be the result of leaching of hydrothermally altered rock; some dump material is also composed of this altered rock. Over the years numerous breaks and leaks in the tailings slurry pipeline have added short-term turbidity to the river.

Molycorp has acted to minimize the various discharges. In 1983, Molycorp began ion exchange treatment of its tailings decant water to reduce molybdenum before discharge to the Red River. Also in 1983, Molycorp eliminated cyanide from its waste stream by substituting another reagent in the ore flotation process. During its most recent shutdown Molycorp completely rebuilt the tailings-slurry pipeline to eliminate accidental leaks and breaks.

To further reduce natural and mine-related environmental impact to the Red River from the Questa mine area, Molycorp is discussing with the New Mexico Environment Department a plan to intercept seeps and runoff. Under the plan, collected drainage would be used as part of mill process water, then discharged to the tailings areas as alkaline tailings slurry.

As of this writing, the mine has been dewatered and is being prepared for the resumption of mining in July 1996, with the mill scheduled to restart in September.

## THE RISE IN RECREATIONAL USE OF THE RED RIVER

The old mining town of Red River is now a ski resort town. Although the permanent population is small, large numbers of tourists pass through in summer and winter. The old sewage treatment system was inadequate for the added burdens, and from 1971 discharged incompletely treated effluent to the Red River, in violation of the NPDES permit. A new advanced sewage treatment plant starting in 1983 met the required discharge limitations. Because phosphate was identified as the limiting algal nutrient in the river, the new treatment plant included steps to reduce phosphate and ammonia to minimize algal growth (Williams Tamburini and Miller 1984).

Other discharges to the Red River come from the waste water lagoon at the village of Questa, and from the state fish hatchery. Smolka and Jacobi (1986) characterized the effects from these as minimal. The area around the town of Red River has numerous vacation homes with individual waste systems.

The Red River is a very popular trout stream. Upstream from the town of Red River, the river supports reproducing populations of cutthroat, brook, and brown trout. For miles downstream from the town and the confluence with the Bitter Creek drainage, trout do not reproduce, but the river is stocked annually with rainbow trout. The river below Questa has a reproducing brown trout population.

The lower four miles of the Red River were given special protection from water quality degradation by the Wild and Scenic Rivers Act of 1968. Although the protected section of the Red River received effluent from the towns of Red River and Questa, the Molycorp mine and mill, numerous abandoned mines, and the state fish hatchery, the water quality was initially described as "exceptional" (Robert Kerr Research Center 1966) and "very good" (U.S. Environmental Protection Agency 1970).

More recent water quality surveys have discovered environmental problems in the Red River. While the water quality is usually good, events such as thunderstorm runoff can cause short-term degradation of water quality, with long-term consequences. The failure of the river to support reproducing trout populations between Red River and Questa has been attributed not to water quality, but to poor habitat caused by cementing of the river bed by precipitated aluminum hydroxide (Smolka and Tague 1987).

Below the village of Questa, no loss of habitat due to aluminum hydroxide precipitate has been noted. The lower stretch of river supports reproducing populations of trout, despite being downstream from Molycorp's tailings decantate discharge.

## SUMMARY

The effects of mining on the Red River are difficult to separate from those from natural inflows low in pH and high in metals. For the reach between the towns of Red River and Questa, the inability of the river to support reproducing trout populations appears to be due primarily to natural degradation.

The Questa molybdenum mine continues to be a source of metals in the Red River, though less than in previous years. The reach of river downstream from Molycorp's main discharge point continues to support reproducing trout populations. Molycorp has acted to minimize negative effects on water quality in the Red River by eliminating cyanide use, reducing molybdenum in the tailings effluent, and by replacing the tailings pipeline to preclude accidental breaks and spills. The company is considering measures to further reduce discharges.

Despite environmental concerns, the Red River remains a popular scenic attraction and trout fishing stream.

## REFERENCES

- Garn, H.S., 1984, Spatial and temporal variations in water quality of the Rio Grande - Red River wild and scenic river, Taos County, New Mexico, *in* New Mex. Bureau of Mines and Mineral Resources, Hydrologic Report 7, p.49-59.
- \_\_\_\_\_, 1985, Point- and nonpoint-source trace elements in a wild and scenic river of northern New Mexico, *Jour. Soil and Water Contamination*, v.40, n.5, p.458-462.
- \_\_\_\_\_, and B.M. Thompson, 1984, Analysis of cyanide data on the Red River of the Rio Grande, New Mexico, *in* Conf. on Cyanide and the Environment, Tucson, Ariz., publ. by Colo. State Univ., Ft. Collins, CO, p.161-174.
- Garrabrant, L.A., 1993, Water resources of Taos County, New Mexico, U.S. Geol. Survey, Water Resources Inv. Rept. 93-4107, 86p.
- Kerr Research Center, 1966, A water quality survey. Red River of the Rio Grande, New Mexico, Robt. S. Kerr Water Research Center, Ada, Okla., PB-227 634.
- Mining Magazine, 1984, The mine in Goat Hill, May 1984, p.434-443.
- Reed, E.F., 1922, Red River mining District of New Mexico, Colorado School of Mines, Golden, Colo., senior thesis T-483, 42p.
- Schilling, J.H., 1960, Mineral resources of Taos County, New Mexico, New Mex. Bureau of Mines and Mineral Resources, Bull. 71.
- Smolka, L.R., and G.Z. Jacobi, 1986, Water quality survey of the Red River, Taos County, New Mexico, New Mex. Health and Environment Dept., EID/SWQB/86/11, 61p.
- Smolka, L.R., and D.F. Tague, 1987, Intensive survey of the Red River, Taos County, New Mexico, August 18-21, 1986, N. Mex. Health and Environment Dept., 55p.
- Smolka, L.R., and D.F. Tague, 1989, Intensive water quality survey of the middle Red River, Taos County, New Mexico, September 12-October 25, 1988, New Mex. Health and Environment Dept., 89p.
- United States Environmental Protection Agency, 1971, A water quality survey, Red River and Rio Grande, New Mexico, U.S. EPA Region VI, Ada, Okla., 52p.
- Williams, R.B., J.U. Tamburini and J.H. Miller, 1984, Protection of surface waters: the AWT plant at red River, New Mexico, *in* New Mex. Bureau of Mines and Mineral Resources, Hydrologic Report 7, p.82-92.

