

# THE ALFALFA WEEVIL IN COLORADO

BY J. H. NEWTON



---

---

COLORADO AGRICULTURAL COLLEGE  
COLORADO EXPERIMENT STATION  
COOPERATING WITH STATE ENTOMOLOGIST  
FORT COLLINS

**The Colorado Agricultural College**  
FORT COLLINS, COLORADO

**THE STATE BOARD OF AGRICULTURE**

J. C. BELL.....	Montrose	O. E. WEBB.....	Milliken
W. I. GIFFORD.....	Hesperus	T. J. WARREN.....	Fort Collins
JAMES P. McKELVEY.....	La Jara	MRS. MARY ISHAM.....	Brighton
H. B. DYE, Pres.....	Manzanola	J. W. GOSS.....	Pueblo

} GOVERNOR W. H. ADAMS  
} PRESIDENT CHAS. A. LORY

L. M. TAYLOR, Secretary                      L. C. MOORE, Treasurer

**OFFICERS OF THE EXPERIMENT STATION**

CHAS. A. LORY, M.S., LL.D., D.Sc.....	President
E. P. SANDSTEN, Ph.D.....	Director
I. D. CRAIN, B.M.E., M.M.E.....	Vice-Director
L. M. TAYLOR.....	Secretary
ANNA T. BAKER.....	Executive Clerk

**EXPERIMENT STATION STAFF**

**Agronomy**

Alvin Kezer, A.M., Chief Agronomist  
David W. Robertson, M.S., Ph.D.,  
Associate  
Roy D. Hockensmith, B.S., M.S.,  
Associate (soils)  
Robert Gardner, B.S., M.S., Assistant  
(soils)  
Dwight Koonce, B.S., M.S., Assistant  
Warren H. Leonard, B.S., M.S.,  
Assistant  
Wayne Austin, B.S., Assistant  
C. H. Dodson, B.S., Assistant (soils)

**Animal Investigations**

George E. Morton, B.S.A., M.S., in  
Charge  
R. W. Fairbanks, B.S., M.S., Associate  
H. B. Osland, B.S., M.S., Associate  
John O. Toliver, B.S., Assistant

**Bacteriology**

W. G. Sackett, Ph.D., in Charge  
Laura Stewart, B.S., M.S., Assistant  
Sarah Stewart, B.S., M.S., Assistant

**Botany**

L. W. Durrell, Ph.D., in Charge  
Anna M. Lute, A.B., B.Sc., Seed  
Analyst  
Bruce J. Thornton, B.S., M.S.,  
Associate  
E. C. Smith, A.B., M.A., M.S.,  
Associate  
E. W. Bodine, B.S., M.S., Assistant  
Melvin S. Morris, B.S., M.S., Assistant  
E. J. Starkey, B.S., M.S., Assistant

**Chemistry**

Earl Douglass, M.S., Acting in Charge  
J. W. Tobiska, B.S., M.A., Associate  
C. E. Vail, B.S., M.A., Associate

**Entomology**

George M. List, Ph.D., in Charge  
C. P. Gillette, M.S., D.Sc., Associate  
W. L. Burnett, Rodent Investigations  
J. L. Hoerner, B.S., M.S., Associate  
Chas. R. Jones, M.S., Ph.D., Associate  
Miriam A. Palmer, M.A., M.S.,  
Associate  
Sam McCampbell, B.S., M.S., Associate  
R. G. Richmond, B.S., M.S., Associate  
J. H. Newton, B.S., Assistant  
Leslie B. Daniels, B.S., M.S., Assistant

**Home Economics**

Inga M. K. Allison, E.B., M.S., in  
Charge  
Mark A. Barmore, Ph.D., Research  
Associate

**Horticulture**

E. P. Sandsten, Ph.D., in Charge  
A. M. Binkley, B.S., M.S., Associate  
Carl Metzger, B.S., M.S., Associate  
Geo. A. Beach, B.S., Assistant  
Earl J. Allen, B.S., M.S., Assistant

**Irrigation Investigations**

R. L. Parshall, B.S., in Charge  
Carl Rohwer, B.S., C.E., Associate  
W. E. Code, B.S., Associate  
R. E. Trimble, B.S., Meteorologist  
L. R. Brooks, B.S., Assistant

**Rural Economics and Sociology**

I. A. Moorhouse, B.S.A., M.S., in Charge  
R. T. Burdick, B.S., M.S., Associate  
B. F. Coen, B.L., A.M., Associate  
D. N. Donaldson, B.S., M.S., Associate  
G. S. Klemmedson, B.S., M.S., Associate  
Carl C. Gentry, A.B., A.M., Associate  
H. B. Pingrey, B.S., M.S., Assistant

**Veterinary Pathology**

I. E. Newsom, B.S., D.V.M., in Charge  
Floyd Cross, B.S., D.V.M., Associate  
Bryce R. McCrory, M.S., D.V.M.,  
Assistant

**Veterinary**

Geo. H. Glover, D.V.M., M.S., in Charge

**Editorial Service**

I. G. Kinghorn, Editor  
Arthur Robinson, Associate Editor  
Esther Horsley, Assistant Editor

**Engineering Division—Mechanical  
Engineering**

L. D. Crain, B.M.E., M.M.E., Head of Di-  
vision in charge of Mechanical Engi-  
neering

\*F. E. Goetz, B.S., M.S., Associate

**Civil Engineering**

E. B. House, B.S., (E.E.), M.S., in  
Charge  
D. A. Wigle, B.S., Testing Engineer

\*Deceased.

# THE ALFALFA WEEVIL IN COLORADO

By J. H. NEWTON\*

The alfalfa weevil *Hypera posticus* Gyll., a native insect of Europe which is known to be widely distributed thruout the Old World, was first discovered in the alfalfa fields of America in 1904 or 1905, near Salt Lake City, Utah. There is little doubt but that this infestation existed for some time previous to discovery. Since that time it has spread to portions of seven of the neighboring states and it appears that its occurrence in all of the alfalfa-producing areas of the Western States is only a matter of time.

## DISCOVERY AND OCCURRENCE IN COLORADO

The presence of the alfalfa weevil in Colorado first became known in the spring of 1917 when an isolated infestation was discovered in a number of fields just east of the city limits of Paonia, in Delta County. Incidentally, this marked the first separate colony apart from the original infestation. Knowing the many avenues thru which the weevil might travel, it becomes a matter of conjecture as to when and how this first infestation reached Colorado. That this new colony had been established several years previous is evident from the amount and extent of the injury at the time of discovery.

Having followed the spread of the alfalfa weevil in Colorado since this first discovery, the author is of the opinion that there have been three separate advances into the state—the first, as this isolated colony in Delta County which has since spread to portions of Gunnison, Montrose and Ouray counties; the second, which was first discovered in 1926, as a continuous spread from Utah and Wyoming on the west and north into Moffat, Routt, Rio Blanco and Garfield counties; the third, detected in 1928, as an extension of the infestation in Grand County, Utah, into the west portion of Mesa County. The source of a somewhat isolated infestation at Glenwood Springs is not known. There is little doubt but what these four separate areas of infestation will soon coalesce into one continuous area extending from the city of Ouray to the northern limits of Western Colorado. See Fig. 1.

The southwestern counties of the state have remained free to date, but with the presence of the weevil at Moab, Utah, and an increasing amount of travel from the west, they are in constant danger of an early infestation.

---

\*Deputy State Entomologist, and Assistant in Entomology Section of The Colorado Experiment Station. The work on the alfalfa weevil has been financed largely by funds from the Office of State Entomologist.

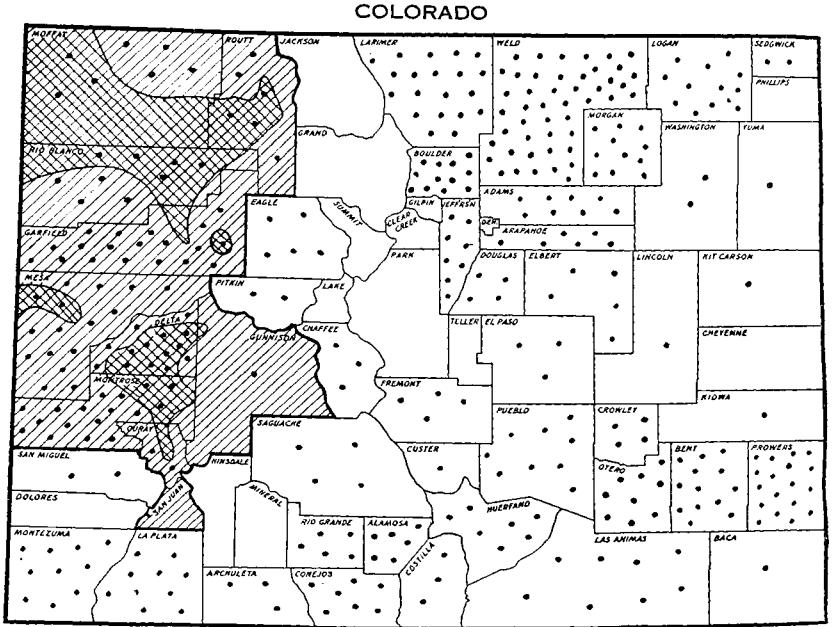

Fig. 1.—Distribution of the alfalfa weevil in Colorado is shown by the double crosshatched area. Double and single crosshatched area represents the counties under quarantine (1932) by outside states. Distribution of the alfalfa producing area of Colorado represented by the dots. Each dot represents 2000 acres of alfalfa.

Careful scouting work has failed to reveal the alfalfa weevil east of the Continental Divide in Colorado. It is most probable that the first infestation in that part of the state will result from a natural spread from Wyoming on the north, rather than from across the Divide, since the insect now exists in several counties of Eastern Wyoming.

While the spread of the alfalfa weevil in Colorado has been spasmodic in nature, the average rate has been approximately 6 miles per season. The insect is now (1932) established in portions of 9 counties. (Fig. 1.) The actual infested area includes, according to data given in Bulletin 89, Colorado State Board of Immigration, "Agricultural Statistics for 1931," 22.1 percent of the alfalfa acreage of the state and 14.9 percent of the total hay acreage.

#### HOST PLANTS

While the alfalfa serves as the primary host for the alfalfa weevil, there are a number of other legumes recorded as host plants, such as some of the native species, peas, sweet, alsike and red clovers. Alfalfa, red and sweet clovers are the only known hosts in Colorado. Once in a great while the sweet clover will show some appreciable

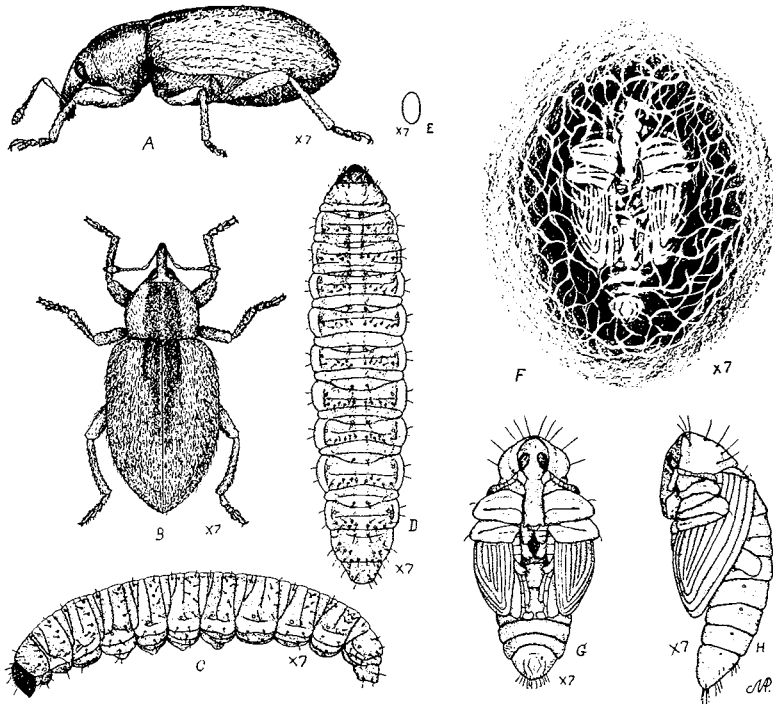

Fig. 2.—Stages in the life cycle of the alfalfa weevil. A, lateral view of adult; B, dorsal view of adult; C, lateral view of larva; D, dorsal view of larva; E, egg; F, pupa within lace-like cocoon; G, pupa ventral view; H, pupa lateral view.

injury when growing on ditch banks and fence rows adjacent to a heavily infested alfalfa field.

#### DESCRIPTION, HABITS AND LIFE CYCLE

**ADULT.**—The adult of the alfalfa weevil is a brown-colored snout beetle three-sixteenths of an inch long. (Fig. 2 A and B.) The color of the newly emerged beetle is light brown, but as the fine scales of the body are rubbed off, the color becomes darker, until the older or hibernating adults may be grey or nearly black.

The adults, which emerge during the months of July and August, enter hibernation in the late fall. During the winter months they are rather inactive except for certain short periods when the sun warms up parts of the field, at which times you may find the beetles crawling about thru the stubble and feeding upon green portions of the plants. For the most part the adults remain in and about the crowns of the plants or where surface cracks and debris afford protection from climatic forces and natural enemies. Winter mortality is often quite high. In the laboratory, adults that over-wintered, often live thru the following growing season, so it is evident that some individuals may live as long as 14 to 16 months.

During the growing season the adults may be found crawling about on the leaves at the tips of the plants. If they are suddenly disturbed or the sun's rays cut off by a passing cloud, many will drop or crawl to the ground, where they are not easily found. Weather conditions affect materially the numbers of adults that may be taken when sweeping a field with an insect net. Winds which keep the tops in continuous motion prevent any degree of success in taking adults during the scouting work.

EGG.—The newly laid egg, measuring only one-thirty-second of an inch in length, is oval in outline and of a bright yellow color, which as incubation progresses, changes to a darker yellow, later to an olive-green and finally to black, as the black head shield of the larva shows thru the shell just prior to hatching. The period of incubation varies from 4 to 35 days according to the temperature and moisture. From Table 1 it will be seen that the incubation period of 3621 eggs was recorded during 3 years of study. The averages by months show a variation from 9.9 days for July, 1918, to 25 days for May, 1919, and the seasonal averages vary from 13.6 to 17 days.

EGG LAYING.—Egg-laying begins in early April and reaches the height usually in the latter part of May. Some scattered egg-laying occurs thruout the season until winter. The larvae from these scattered eggs are not numerous enough to seriously damage a crop, but they are apparently so much less affected by parasites and cultural practices, than the main part of the brood, that they may be very important in the development of adults that over-winter. Reeves and Hamlin\* have called attention to the importance of this in the statement "that the apparently unimportant second-crop larval population is so little affected by either biological or cultural kill, that it serves to maintain the adult population at an economically dangerous level."

The first eggs are laid within old grass stems before the alfalfa plants have made any growth, but as the alfalfa stems become large enough they are selected for oviposition. Two types of stem punctures are made by the beetles, viz: Feeding punctures and egg punctures. The former are somewhat superficial and consist of irregular shallow holes eaten into the stem. This feeding does not result in material injury to the plant. In the case of the egg puncture, the female beetle by the use of her long snout-like proboscis, makes a deep regular outlined hole to the center of the stem cavity and therein lays one or more eggs, after which she may plug the hole with excrement.

---

\*The Use of Mathematics in the Alfalfa Weevil Investigation by Geo. I. Reeves and Dr. J. C. Hamlin, U. S. Bureau of Entomology. Report of the Eighth Annual Rocky Mountain Conference of Entomologists, 1931.

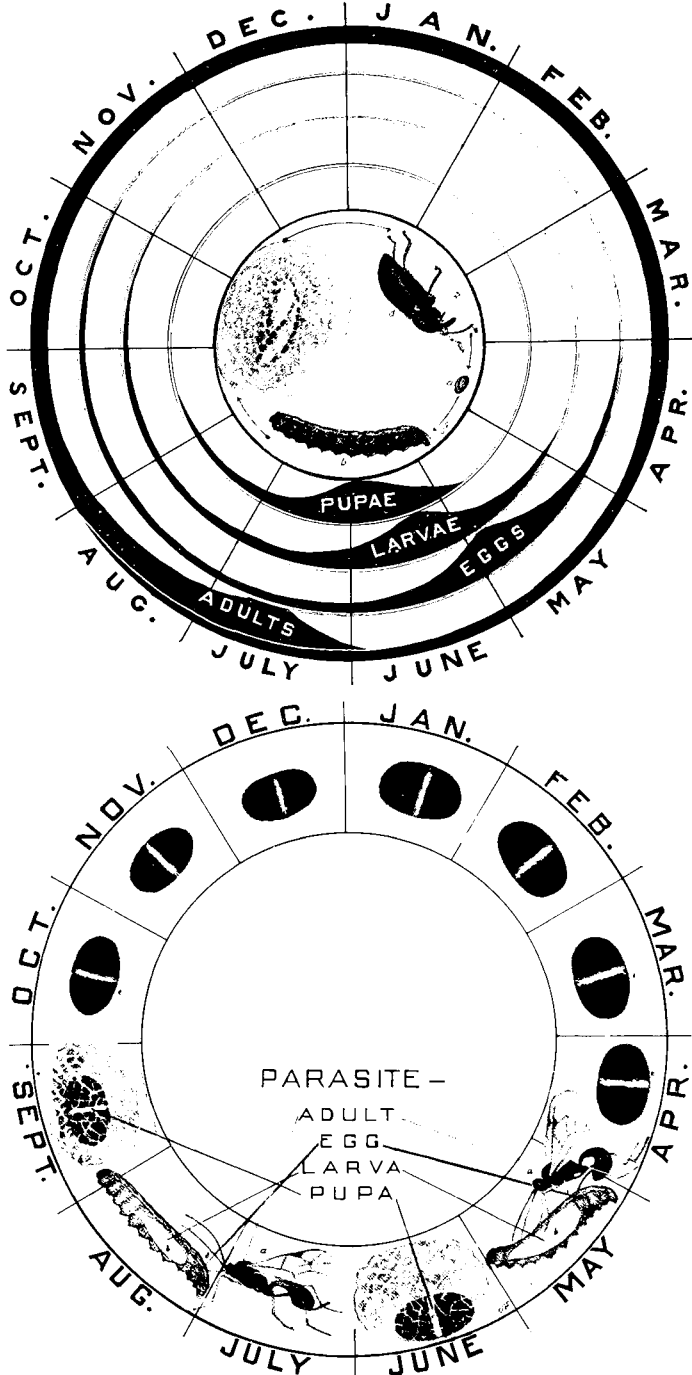

Fig. 3.—Annual Cycles of Alfalfa Weevil (*Hypera posticus*) and its Parasite (*Bathyplectes Curculionis*)

1. Alfalfa weevil (*Hypera posticus*); a, egg; b, larva of weevil; c, pupa in its gauzy cocoon; d, adult beetle or weevil. Enlarged three times. M. A. Palmer, delineator.

2. Alfalfa-weevil parasite (*Bathyplectes Curculionis*); aa, first and second brood of parasite, depositing eggs in the weevil larvae; bb, grubs of first and second brood of parasite within the bodies of the weevil larvae; c, black, banded cocoon of the parasite within the gauzy cocoon of the weevil; d, eggs of parasite beneath the surface and not visible; e, cocoons of parasite, September to April. M. A. Palmer, delineator.

The rise and fall in number of eggs, larvae, pupae and adult beetles for the year are shown by the concentric black circles, there being (1) annual brood of the weevil and (2) of the parasite.

Table I.—Monthly Average—Length in days of the life cycle of *Hypera posticus*.—Paonia, Colorado.

Year	Month	Egg	Larva	Pupa	Egg, larva and pupa	Monthly	Precipitation	
						Mean Temperature		
1918	May	17.3	22.0	11.0	50.3	52.8	T	
	June	10.2	18.4	13.0	41.6	67.4	0.82	
	July	9.9	19.9	13.6	43.4	67.4	0.48	
	August	17.0	24.4	18.0	59.4	67.2	0.85	
			13.6	21.8	13.9	49.2	Season average	
			4.0	9.0	10.0	23.0	Minimum	
			34.0	31.0	21.0	86.0	Maximum	
1919	May	25.0	23.6	10.1	58.7	60.1	1.52	
	June	15.09	15.0	9.4	39.49	66.6	0.00	
	July	11.0	15.3	10.2	36.5	74.2	1.23	
			17.0	17.7	9.9	44.6	Season average	
			9.0	11.0	6.0	26.0	Minimum	
			35.0	30.0	19.0	84.0	Maximum	
1920	May	17.0	20.8	14.8	52.6	58.8	3.50	
	June	15.0	21.1	12.4	48.5	65.0	0.28	
	July	12.0	16.0	15.7	43.7	71.8	1.60	
	August	16.0	23.0	21.2	60.2	71.6	1.25	
			15.0	20.3	16.0	51.3	Season average	
			7.0	14.0	10.0	31.0	Minimum	
			32.0	26.0	25.0	83.0	Maximum	

The above table is made up from laboratory records of 3621 eggs, 184 larvae and 145 pupae.

Table II.—Individual Oviposition Records of Alfalfa-Weevil Females. 1920.

Female No.	Dates of oviposition	Eggs deposited	Percentage	Days of Fertility	Average	Number
			eggs Fertile		daily Ovi-position	days Ovi-position
1	May 12 to July 23	1073	36.7	29	15.1	71
2	May 13 to July 11	687	88.6	52	11.4	60
3	May 14 to July 9	889	86.3	48	17.4	51
4	May 14 to July 17	863	31.0	61	14.3	61
5	May 18 to August 8	1187	84.5	81	14.3	81
6	May 18 to July 21	922	80.8	81	13.9	61



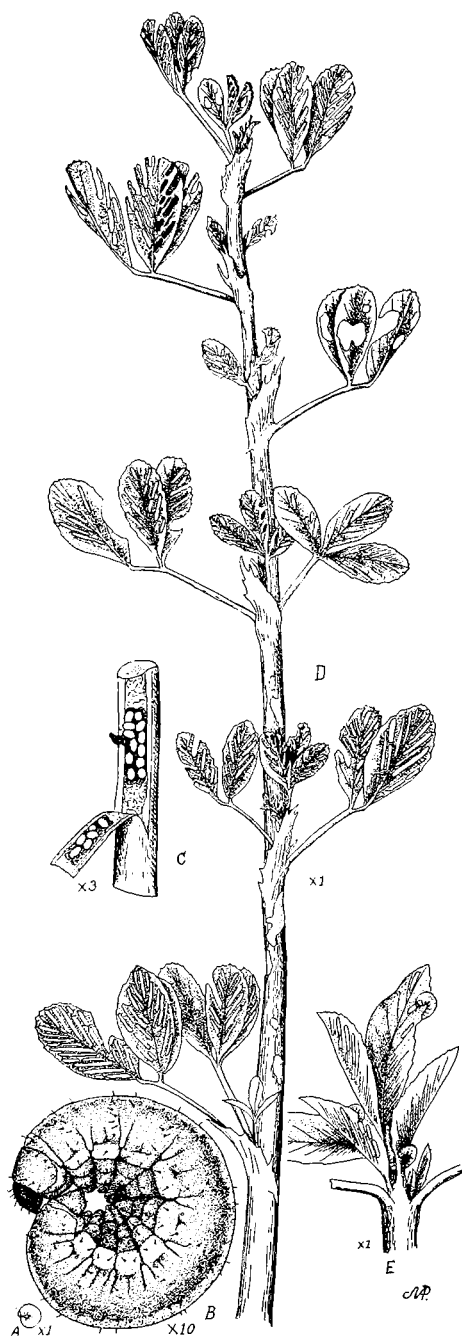

(Fig. 4 C.) Many of the egg punctures are left entirely open. Three hundred and twenty-one punctures examined averaged 16.3 eggs. Sixteen eggs averaging only one-thirty-second of an inch in length require very little space, therefore it is not difficult to imagine them placed in the cavity of a grass or alfalfa stem.

Six isolated females held in laboratory cages from May 12 to Aug. 28, averaged from 11 to 17 eggs per day of oviposition, with from 51 to 83 days of active oviposition. From 687 to 1187 eggs were deposited by individual female beetles. The period of fertility of the isolated females varied from 29 to 81 days. It is apparent from this record that it does not require many of the over-wintering females to build up a heavy infestation in the field each spring. (See Table 2.)

**LARVA.**—The newly hatched larva is so small that it is easily overlooked by even the most careful observer. When mature it measures about one-fourth inch in length. There are normally four instars dur-

Fig. 4.—A, larva, natural size; B, larva, showing characteristic position when disturbed; C, alfalfa stem with weevil eggs and the egg puncture exposed; D, typical injury to the plant caused by the feeding of the alfalfa weevil. The numerous areas have been eaten from the leaves by the larvae. The large scars on the stem show where the epidermis was eaten away by the adults; E, characteristic feeding position of larvae on the plant.

ing the development. During the first instar the predominate color is a yellowish-green. This changes to a darker green, but is always somewhat lighter than the green of the alfalfa plant. The larva is characteristically marked by a black head shield and a white dorso-medial line extending the full length of the body (Fig. 2, C and D.) Immediately following the casting of the old skin at moulting time the head capsule may for a short time have a yellowish-orange color. The length of the larval stage may vary a great deal. With the 184 individuals recorded in Table 1 the minimum is 9 days and the maximum 31. The shortest monthly averages occur during June and July. The seasonal averages vary from 17.7 to 21.8 days. The average length of the various instars, which are the periods between moults, as shown by 141 observations was, first, 4.8 days; second, 4.3 days; third, 5.3 days; fourth, 7.3 days.

Upon emerging from the eggs the larvae are so very small that it seems almost improbable that they could work their way from the egg cavity to the growing tips, where their first feeding takes place. Here they crawl into the new unfolding leaves and soon their presence is indicated by the leaf perforations and excrement. It is characteristic of the larvae to curl their body over the edge of the leaf while feeding (Fig. 4 E.) and when disturbed, to curl tightly and fall to the ground. The latter characteristic makes the sweeping of the tips of the plants a valuable method of gathering larvae to determine infestations, and forms the basis for the scouting work.

PUPA.—When the larva reaches maturity it leaves the plant and crawls or drops to the ground where it constructs a lace-like cocoon preparatory to pupation. (Fig. 2 F, and Fig. 3). Within this frail cocoon attached to a small particle of leaf or grass stem, it passes thru the prepupal and pupal periods and emerges as the adult in from 10 days to 2 weeks. Following the cutting of the first crop, many larvae and pupae are killed by the heat of the sun as they lie in the unprotected cocoons. For several days following their emergence, the chitinous covering of the new adult remains soft, during which time they are more subject to mechanical injury than usual.

#### TIME AND EXTENT OF INJURY

It is the feeding of large numbers of larvae which causes severe damage to the alfalfa crop. Maximum injury therefore takes place when the greatest numbers of larvae are present. This time is directly affected by temperature and moisture conditions. Factors such as late frost and drouth, which retard the plant growth, may have less effect upon the weevil, consequently the larvae may gain such an advantage that the plants can never overcome the injury, thus resulting in a nearly complete destruction of the first crop. This damage by the larvae takes place during the last 2 weeks of the growth of the first cutting.

The first weevil injury of the season may be found in the growing tips of the plants and as the larval population increases and the food supply becomes scarce, the plants are unable to make a normal growth. In cases, all of the leaves may be completely consumed, except for the midribs and the large veins. (Fig. 4 D.) Even the epidermis, (green outer covering) may be stripped from the stems. A field injured to this extent, has an ashy grey appearance, so apparent that it might be mistaken for frost injury. Such a crop is a total loss, the hay being light, chaffy, dusty and unpalatable to livestock. Chronic coughing in livestock may be caused by "weevil dusty" hay. Partial or complete checking of the bloom results in the loss of seed crop and honey flow, when the first cutting is depended upon for these.

Following the first cutting, the immature larvae leave the cut hay and eat the new shoots of the second crop as fast as they appear. If the first cutting has been cut prematurely, this type of injury may continue for 2 or 3 weeks, or until the larvae quit feeding at maturity. Thus the second cutting is retarded, and the third may be thrown into early frost in the fall.

#### SCOUTING METHOD

A close record of the spread of the alfalfa weevil in the state has been made by annually scouting the principal alfalfa-producing sections, giving special attention to the establishing of the borders of the known infestations and detecting the possible occurrence of undiscovered outbreaks. This is best accomplished by sweeping the tips of the plants with an insect net.

Since the larvae are more easily taken in the net than the adults, the scouting work is best carried on during the peak of the larval activity. The period for effective scouting work extends over approximately a 2-week period in any one locality. It is not possible to visit every field in a given area, so in the counties classed as uninfested, only representative fields are selected. When scouting on the boundary of the known areas of infestation, larger numbers of fields are checked upon. Repeated scouting notes in a given area from season to season have proved the value of the scouting method in determining the boundaries of weevil infestation.

#### DISSEMINATION

NATURAL SPREAD.—Dissemination of the weevil to new areas thru its own power of locomotion is confined primarily to the adult. The small, almost legless, larvae do not move beyond the immediate host plant. This is shown in the spraying experiments where the check plots may be nearly destroyed, while the treated plots immediately adjacent show practically no migration of the young larvae. The usual activity of the adult is to crawl about from one plant to another

in a rather aimless manner which would carry it no great distance. However, there are recorded instances of pronounced flight during a warm period of the day. Such flights are considered the most important means of natural spread from the borders of infestation. Air currents which occur at the time of flight may determine the direction and retard or extend the rate of spread.

**ARTIFICIAL AGENCIES.**—Many artificial agencies enter into the spread of the weevil. It is impossible to determine how the insect has become established in new colonies or to know all avenues of future spread. Natural topographical barriers seem to have checked the rate of spread for a time in some localities. Irrigation waters, wind currents, tourist travel and commerce are important potential carriers. Records of the adults floating in the waters of irrigation canals would indicate that this is a very important manner of dispersion. Hays and straws are considered the most important carriers, among the agricultural products, and are therefore made the basis for most of the interstate quarantines.

#### QUARANTINES

Twenty-two states maintain interstate quarantine regulations against all counties infested. All of these forbid the movement into their state of all hays and straws or commodities carrying hays or straws. Several require that all potatoes be screened immediately before loading. The details of these requirements can usually be secured from the local railroad agent.

The Office of State Entomologist of Colorado maintains intrastate regulations forbidding the movement of hays and straws from the infested areas. These local quarantines have not always been fully understood by the people within, or without the restricted areas. Quarantines were never expected to prevent the spread of the weevil that can be expected from flight and other natural means. They are intended to:

1. Prevent the promiscuous hauling of hays and straws and thus cut off the most important avenue for the carrying of the insect into uninfested areas.

2. To meet the quarantines of 22 states, thus assuring these states that we are reasonably careful to see that our agricultural products are not carriers of the weevil.

3. To keep outside markets open for all hay grown in the uninfested territory.

#### CONTROL

**ARTIFICIAL.**—Cultural practices are important in weevil control. Spring cultivation which stirs the soil and stimulates rapid plant growth will often give the crop such a vigorous start that the injury from a moderate infestation may never be apparent. Poor tillage,

improper irrigation and frost are often responsible for spotted injury in a field where the infestation is approximately uniform. Plants with low vitality show the first weevil injury. In general it might be said that good farmers complain the least of weevil injury and when control measures are necessary they will apply them at a small cost and continue to grow profitable crops regardless of the weevil.

The only reason for plowing up an alfalfa field under weevil conditions, is that of good farming practice in rotation, or to do away with an old stand which has lost its vitality.

Early pasturing is not an economical nor practical control because the numbers of animals for effective pasturing are not readily available and in general it does not work well into the usual farming practice. Heavy pasturing by means of sheep is one recognized pasturing method. This keeps down the early growth of the alfalfa plants until after the most of the weevil eggs are laid. This would necessarily have to be carried on to the first of June at least.

SPRAYING.—While several methods, such as early cutting, dust mulching, brush dragging, silting and pasturing have been tried, the most economical and effective method has been that of spraying or dusting the tips of the plants with an arsenical. Lead arsenate, calcium arsenate and zinc arsenite have given excellent control when applied at the rate of 1 pound to each 50 gallons of water. Thoro application of the spray to the tips of the plants and at the right time are two main factors in successful control.

WHEN TO SPRAY.—Weevil control depends upon poisoning the larvae as they feed upon the growing tips; therefore a spray applied at the time the greatest number of larvae are feeding, will effect maximum control. This occurs some time during the last 2 weeks growth of the first crop. The spray should be applied when injury to the tips becomes apparent. Very often such injury appears about the time the first blossom buds have formed. There is a period of 4 or 5 days following noticeable injury, that a spray will save the first crop and protect the return growth of the second crop. Another method of determining the proper time for spraying has been that of sweeping the tips of the plants with a 12-inch insect net, to determine when 1000 larvae can be taken in 100 strokes of the net. However, there is no set rule that can be established, as weather and local conditions of the field affect directly the weevil activities.

#### SPRAYING PROTECTS THE FIRST AND SECOND CROPS

Spraying at the proper time will save the first cutting and protect the return growth of the second crop. In our experimental plots, sprayed portions have matured a good first cutting and the return growth of the second crop has made 5 to 6 inches of return

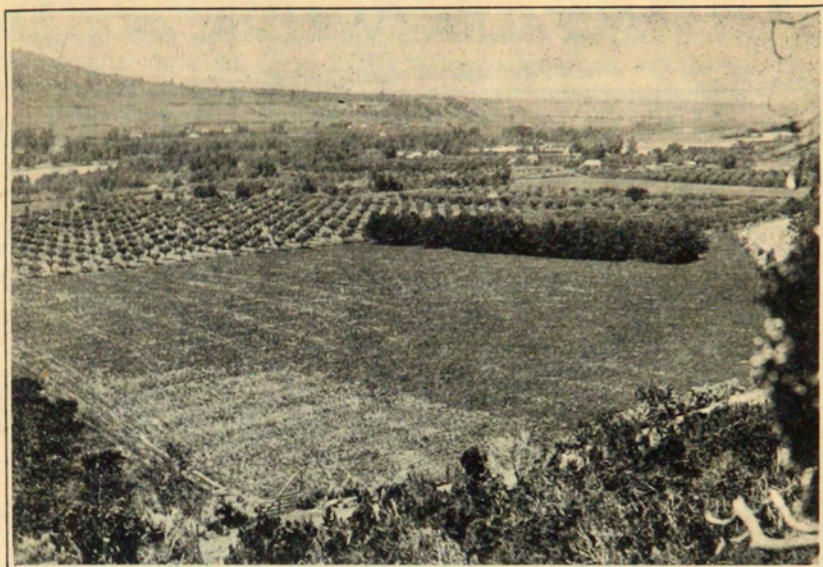

Fig. 5.—Example of the return growth of the second crop of alfalfa following the spraying and cutting of the first crop. The darker portion of the field shows the return growth on the sprayed area, while the light portion in the foreground is the check plot which was not sprayed.

growth, before the unsprayed plot would show green. (Fig. 5.) This retardation of the return growth may continue for 2 or 3 weeks. Sprays applied too early or late will not return maximum value in control. Spraying will not reduce the population of the weevil to the point of giving protection the following season, but must be pursued each year, if seasonable conditions are favorable for weevil development. The effect of proper spraying may be judged from Fig. 6, which shows graphically the results of spray practice in 1919 and 1920.

#### MATERIALS FOR SPRAYING

Calcium arsenate, zinc arsenite or lead arsenate used at the rate of 2 pounds to the 100 gallons of spray have given excellent control; however, the lead arsenate is not recommended as lead is an accumulative poison when fed to animals.

#### EQUIPMENT AND COST

Fortunately the first weevil outbreak occurred in an orchard section where power spraying equipment was at hand. In such localities the orchard sprayers can be readily adapted to the work with little expense. A spray boom adaptable to most of the orchard sprayers can be made as described in the annual report of the State Entomologist's Office for 1918.

# ALFALFA WEEVIL

PAONIA COLORADO 1919

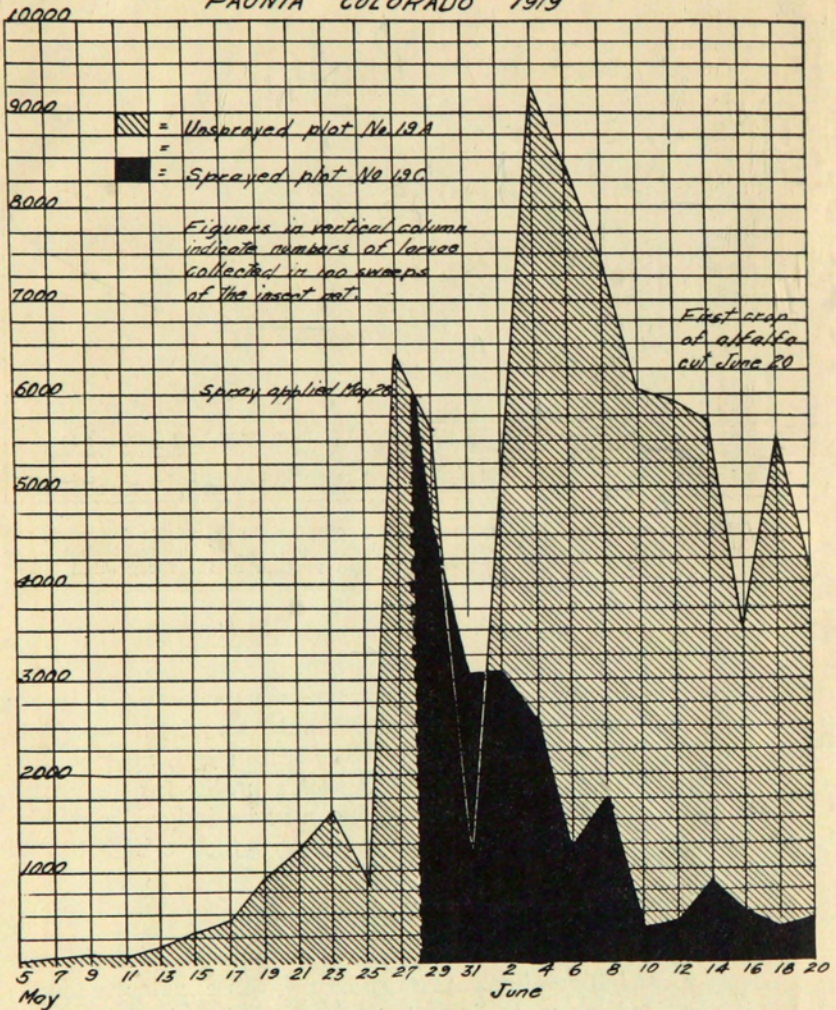

Fig. 6.—Crosshatched area shows number of larvae collected in unsprayed plot each second day thruout growing period of first crop. Dark area shows number of larvae after date of spraying in sprayed plot of same field. Spray applied May 28, just before the larvae appeared in the maximum number. Note reduction in number of larvae due to spraying. Little injury was done to either first or second crop in sprayed plot. (Original in State Entomologist Circular 28, Eleventh Annual Report of the State Entomologist of Colorado.)

"In place of the regular spray hose and rods, the pipe from the pump discharge was connected by short pieces of hose to a special spray attachment. (Figs. 7 and 8). By means of strap iron and bolts, a two-by-four was fastened to each of the upright pipes supporting the hood over the

engine. This two-by-four was attached to the iron straps in such a way that it pivoted on the bolt and could be raised and swung forward like a hinge, to allow the spray outfit to pass thru gates. (Fig. 7). Bolts holding the straps to the upright pipes were readily adjustable so that the wooden supports could be raised or lowered as the height of the crop might demand. Extending from the top of the engine hood was a chain which was fastened to a hook in the two-by-four so that the outer ex-

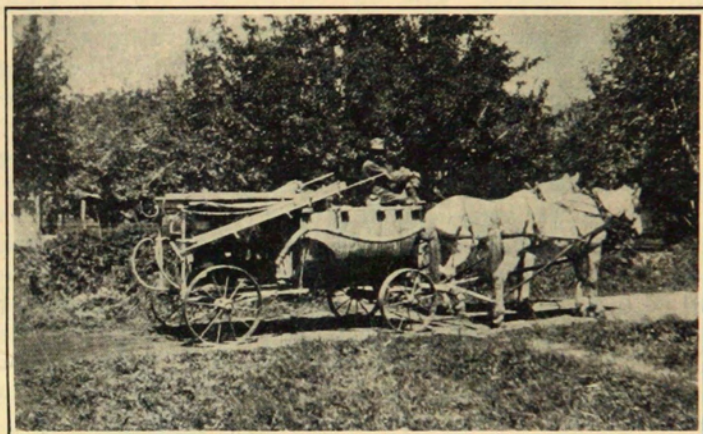

Fig. 7.—Spraying outfit showing arms folded forward. (Original in State Entomologist Circular 27, Tenth Annual Report of the State Entomologist of Colorado.)

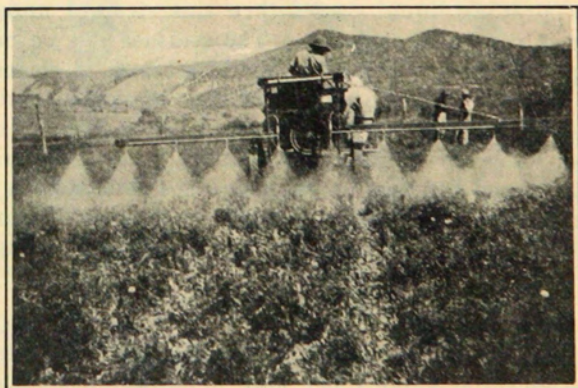

Fig. 8.—Spraying machine in operation in alfalfa field. (Original in State Entomologist Circular 27, Tenth Annual Report of the State Entomologist of Colorado.)

tremity might be held at any height desired. To each wooden support was attached by U bolts one-half-inch galvanized iron pipe made up of four sections of two-foot lengths connected by T's with a T at one end and an L at the other or farthest end from the engine. To each T and L



was then coupled a Meyers self-cleaning spray nozzle. To make the connection it was necessary to use a one-fourth-inch bushing and a short one-fourth-inch nipple for each nozzle. To the T nearest the engine was connected a hose leading from the discharge pipe. The pipe nozzles could cover a swath of ground 20 feet in width, or by swinging the arms to the rear of the engine, any desired width down to 4 or 5 feet could be covered. The wooden arms were used to secure lightness with stability and to strengthen the pipe to withstand the vibration from driving the machine."

This boom is adaptable, with minor changes, to any type of power sprayer. Where orchard sprayers are not available, the 100-gallon capacity, traction sprayers with spray boom attachment can be purchased and equipped for approximately \$325, which, if properly managed, would conveniently take care of 300 acres of alfalfa. It requires 100 gallons of spray solution per acre. Operating time requires from 30 to 40 minutes per acre, depending upon the proximity of the water supply and the type of outfit. The cost of material, operation of sprayer, depreciation and labor for a traction sprayer should not exceed \$1.00 to \$1.25 per acre annually. This is not prohibitive when one considers the possible loss and the value of alfalfa to western agriculture. Lack of equipment and preparation often cost in one season what several seasons of control and preparedness would amount to.

In operating a spray boom with 12 or 15 nozzles it is essential that there be no trouble with clogging nozzles. This is best accomplished by means of a practical spray strainer as illustrated in Fig. 9. All of the spraying liquid passes thru this strainer under pressure just before it reaches the nozzles. The strainer can be made out of standard plumbing supplies at a small cost and if cleaned once or twice a day there should be no loss of time or materials due to clogging nozzles. The strainer as illustrated uses a copper screen cone which has a tendency to break down under pressure. This has been overcome in actual practice by replacing the cone with a perforated brass cylinder which fits tightly between the plug and the upper bushing. The brass cylinder can be easily removed for cleaning.

#### FEEDING SPRAYED HAY

The question often arises as to the dangers of feeding sprayed hay. Applying 100 gallons per acre of spraying solution gives 2 pounds of calcium arsenate per acre, which is very little poison in proportion to the bulk of hay harvested.

Mr. Geo. I. Reeves\*, of the U. S. Bureau of Entomology, states that 30 pounds of sprayed hay contains from 1 to 29 grains of white arsenic and most usually 5 to 10 grains. If 30 pounds of hay is con-

---

\*Reeves, Geo. I. *Journal of Economic Entomology*, Vol. 18, p. 83-9, 1925.

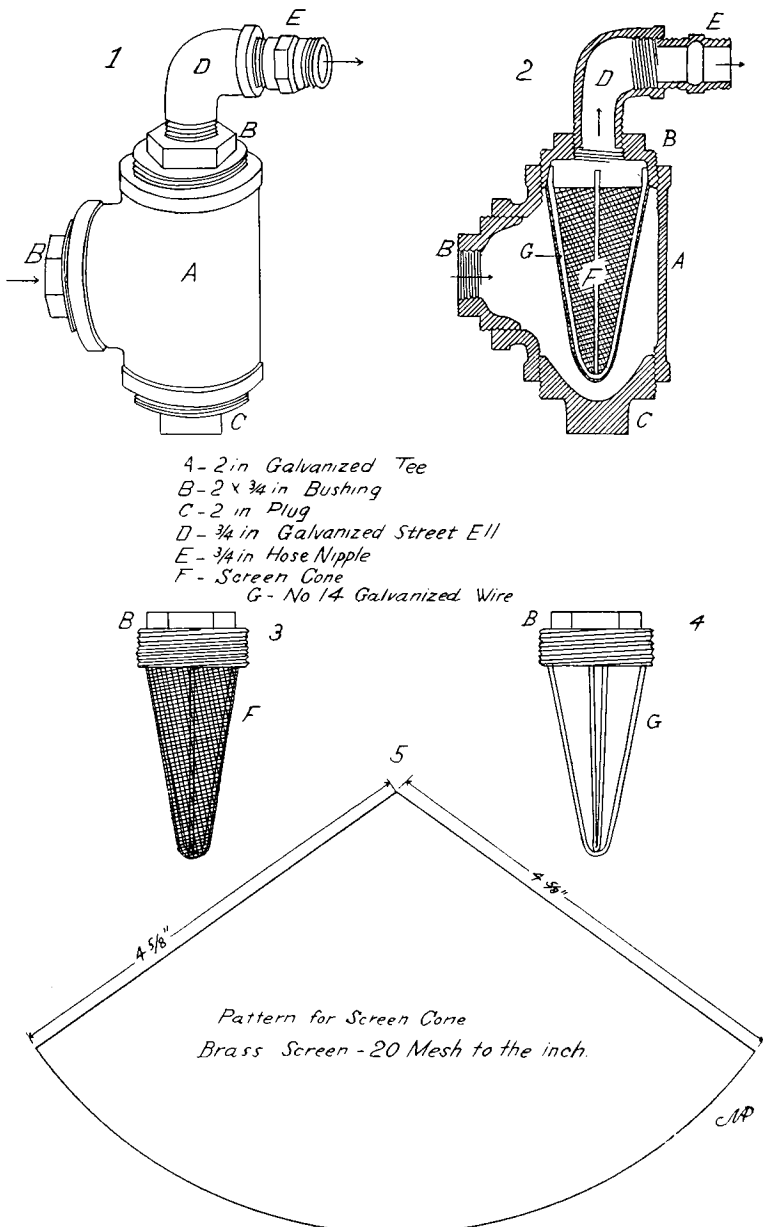

- A - 2 in Galvanized Tee
- B - 2 x 3/4 in Bushing
- C - 2 in Plug
- D - 3/4 in Galvanized Street Ell
- E - 3/4 in Hose Nipple
- F - Screen Cone
- G - No 14 Galvanized Wire

Fig. 9.—A Practical Spray Strainer. Prevents clogging of nozzles by rust, scale and other foreign materials in liquid. Easily cleaned by removing plug C. Most heavy particles drop from screen when pressure is removed. Strainer should be attached in pressure line between cut-off and hose. Liquid is forced under pressure, into tee thru wide bushing and upward thru screen, as indicated by arrows. The arch formed by the No. 14 wire prevents screen from collapsing. Adapted with modifications from U. S. Bureau of Entomology, Salt Lake City Station. Successfully used by this office at Paonia, Colorado. A cylinder of perforated brass which fits snugly between the bushing B and the plug C, has been found to be more satisfactory than the screen cone as illustrated. The cylinder can be easily removed for cleaning by removing the plug C. While the cone sometimes breaks down under pressure, the cylinder has never failed to stand up, even when severely clogged. (Original in State Entomologist Circular 34, Twelfth Annual Report of the State Entomologist of Colorado.)

sidered a day's ration, this is entirely within the limit of tolerance of horses and cattle. Samples of sprayed hay taken from the sprayed plots at Paonia, were analyzed by Dr. W. P. Headden\* of the Colorado Experiment Station with the report that he believed none of the hay contained enough arsenic to make it unsafe for stock food. These analyses showed 6.5 to 17.5 parts per million of arsenic trioxide in a field sprayed with 2.5 pounds zinc arsenite per acre. Properly sprayed hay has been fed in Utah and Colorado for a number of years without any ill effects. Hay from orchards where large quantities of poison from the several orchard sprays have accumulated upon a small quantity of hay is an entirely different matter. Cases of live-stock poisoning have been reported from the feeding of such hay. In orchard practice the hay received many times the amount of poison applied in alfalfa-weevil control.

#### DUST APPLICATION OF POISON

Some preliminary work in the use of arsenical dusts has been conducted in Colorado with a certain degree of success. While there are advantages over liquid in its use and future conditions may warrant its adoption, our experience so far does not warrant its general recommendation.

#### NATURAL CONTROL

Soon after the discovery of the alfalfa weevil in America, the U. S. Bureau of Entomology started a program of introducing native European parasites into the colony at Salt Lake City. Only one of the parasites, *Bathyplectes curculionis* Thoms, has been successfully established in America. *Bathyplectes curculionis* had become well established in Utah at the time of the first weevil infestation in Colorado, so, thru the cooperation of the Salt Lake laboratory, introductions were made into Delta County in the spring of 1918.

Parasitism has rapidly increased until it is now present in all infested portions of the state, and has shown an 80 to 90 percent parasitism of mature larvae in many of the fields. It is difficult to evaluate the good that this parasite may do.

#### HOW THE PARASITE WORKS

It is of interest to note how the parasite, *Bathyplectes curculionis*, really works. It is a small hymenopterous wasp, known as an ichneumon fly which searches out the weevil larva and oviposits her eggs within the body, by means of an egg-laying organ or ovipositor. (Fig. 10 A). The larva of the parasite then feeds within the body of the weevil larva which does not usually succumb to the ravages of the parasitic larva until it has spun its own cocoon. The cocoon of the parasite is a small brown capsule with a distinct transverse

\*10th Annual Report, State Entomologist, Colorado, p. 32.

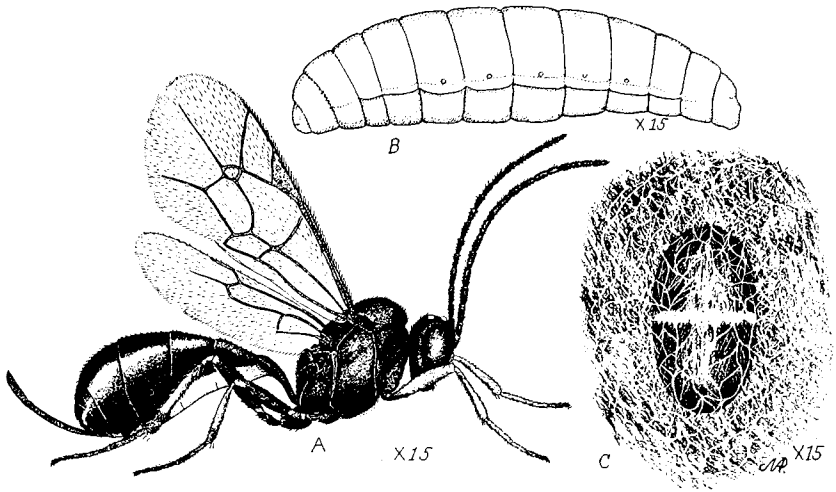

Fig. 10.—An introduced parasite (*Bathyplectes curculionis*) of the alfalfa weevil. A, adult parasite. The egg of the parasite is oviposited within the body of the weevil larva by means of the curved ovipositor or egg-laying organ. B, mature parasite larva at the time of leaving the body of the parasitized weevil larva; C, characteristic parasite cocoon within the lace-like cocoon of the weevil. The parasite cocoon may be within or free from the weevil cocoon, depending upon whether the weevil larva lived to make the cocoon.

medial white line or band. (Fig. 10 C). Some of the parasitized weevil larvae have not the vitality to spin a cocoon, therefore, in such cases the parasite cocoon will be found entirely free from any weevil cocoon. Parasitized weevil larvae are a little lighter green but are nearly as active as normal.

#### ACKNOWLEDGMENTS

To the following persons who have served the Experiment Station in gathering data herein presented: Prof. Claude Wakeland, W. P. Yetter, Jr., and several who have acted as summer assistants.

To Geo. I. Reeves and other members of the U. S. Bureau of Entomology at Salt Lake City for their cooperation and timely suggestions.

Acknowledgment also is made to Drs. C. P. Gillette and Geo. M. List, who have directed the work.

