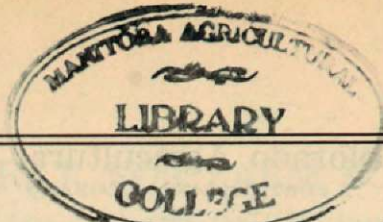


08

Colorado



3) Bulletin  
4) Number 308

April, 1926

2) Agricultural Experiment Station

# ADOBE BRICK FOR FARM BUILDINGS

By JOHN W. SJOGREN AND J. W. ADAMS

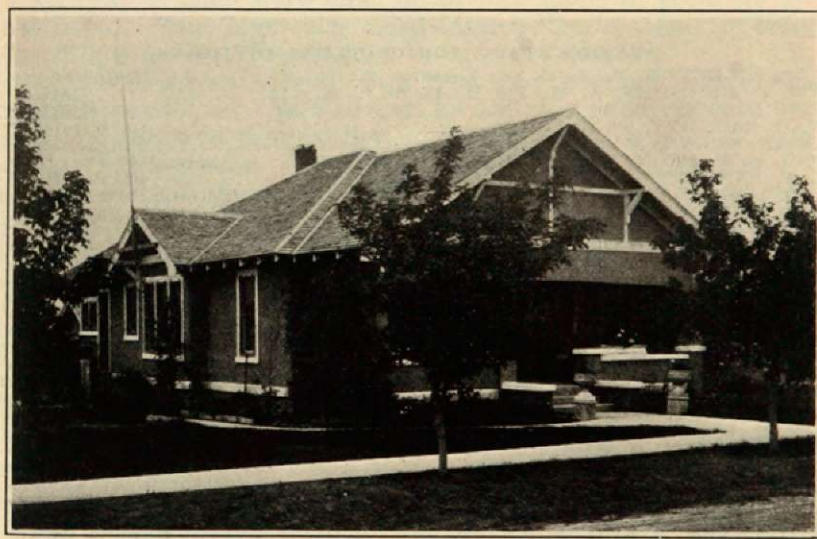


Figure 1. Bungalow built of adobe brick and stuccoed.

COLORADO AGRICULTURAL COLLEGE  
EXPERIMENT STATION  
FORT COLLINS

# The Colorado Agricultural College

FORT COLLINS, COLORADO

## THE STATE BOARD OF AGRICULTURE

J. C. BELL.....Montrose	A. A. EDWARDS, Pres., Fort Collins
JOHN F. MAYES.....Manitou	J. S. CALKINS .....Westminster
W. I. GIFFORD.....Hesperus	E. R. BLISS.....Greeley
J. E. RYAN.....Rocky Ford	MARY ISHAM .....Brighton
Ex-Officio	
GOVERNOR C. J. MORLEY	PRESIDENT CHAS. A. LORY
L. M. TAYLOR, Secretary	L. C. MOORE, Treasurer

## OFFICERS OF THE EXPERIMENT STATION

CHAS. A. LORY, M. S., LL. D., D. Sc. ....	President
C. P. GILLETTE, M. S., D. Sc. ....	Director
LD CRAIN, B. M. E., M. M. E. ....	Vice Director
L. M. TAYLOR .....	Secretary
ANNA T. BAKER .....	Executive Clerk

## STATION STAFF AGRICULTURAL DIVISION

C. P. GILLETTE, M. S., D. Sc., Director .....	Entomologist
WM. P. HEADDEN, A. M., Ph. D., D. Sc. ....	Chemist
G. H. GLOVER, M. S., D. V. M. ....	Veterinarian
W. G. SACKETT, Ph. D. ....	Bacteriologist
ALVIN KEZER, A. M. ....	Agronomist
GEO. E. MORTON, B. S., M. L. ....	Animal Husbandman
E. P. SANDSTEN, M. S., Ph. D. ....	Horticulturist
B. O. LONGYEAR, B.S., M.S. ....	Forestry Investigations
I. E. NEWSOM, B. S., D. V. S. ....	Veterinary Pathologist
L. W. DURRELL, Ph. D. ....	Botanist
RALPH L. PARSHALL, B. S. ....	U. S. Irrig. Eng. Irrigation Investigations
R. E. TRIMBLE, B. S. ....	Assist. Irrig. Investigations (Meteorology)
EARL DOUGLASS, M. S. ....	Associate in Chemistry
P. K. BLINN, B. S., Rocky Ford .....	Alfalfa Investigations
MIRIAM A. PALMER, M.A., M.S. ....	Delineator and Assistant in Entomology
J. W. ADAMS, B. S., Cheyenne Wells .....	Assistant in Agronomy, Dry Farming
*CHARLES R. JONES, B. S., M. S. ....	Associate in Entomology
CHARLES I. BRAY, B.S., M.S., Ph.D. ....	Associate in Animal Investigations
E. J. MAYNARD, B.S.A., M.S. ....	Associate Animal Husbandman
W. L. BURNETT .....	Rodent Investigations
FLOYD CROSS, D. V. M. ....	Assistant Veterinary Pathologist
WM. H. FELDMAN, D. V. M. ....	Assistant Veterinary Pathologist
J. H. NEWTON, B. S. ....	Assistant in Entomology
CAROLINE PRESTON .....	Artist in Botany Section
J. L. HOERNER, B. S. ....	Assistant in Entomology
J. W. TOBISKA, B. S., M. A. ....	Assistant in Chemistry
C. E. VAIL, B. S., M. A. ....	Assistant in Chemistry
C. D. LEARN, B. S., M. A. ....	Assistant in Botany
DAVID W. ROBERTSON, B. S., M. S. ....	Associate in Agronomy
I. G. KINGHORN .....	Editor
R. A. MCGINTY, B. S., A. M. ....	Associate in Horticulture
C. M. TOMPKINS, B.S., M.S. ....	Assistant in Horticulture
L. A. MOORHOUSE, B. S. A., M. S. ....	Rural Economics
R. T. BURDICK, B. S., M. S. ....	Associate in Rural Economics
CHAS. N. SHEPARDSON, B. S., M. S. ....	In Charge of Official Testing
J. C. WARD, B. S., Rocky Ford .....	Soil Chemistry
J. W. DEMING, B. S. A. ....	Assistant in Agronomy
H. B. PINGREY, B. S. ....	Assistant in Agricultural Economics
IDA WRAY FERGUSON, R. N. ....	Assistant in Bacteriology
ROSS C. THOMPSON, B.S., M.S. ....	Assistant in Horticulture
DWIGHT KOONCE, B. S. ....	Assistant in Agronomy
E. A. LUNGREN, B.S., M.S. ....	Assistant Plant Pathologist
CHARLES ROGERS, B.S., M.S. ....	Assistant in Botany

## ENGINEERING DIVISION

L. D. CRAIN, B.M.E., M.M.E., Chairman .....	Mechanical Engineering
F. B. HOUSE, B. S., (E. E.) M. S. ....	Civil Engineering
O. V. ADAMS, B.S., M.S.E. ....	Associate in Civil Engineering
G. A. CUMINGS, B. S. ....	Assistant in Mechanical Engineering

\*On leave 1925-26.

# ADOBE BRICK FOR FARM BUILDINGS

BY JOHN W. SJOGREN AND J. W. ADAMS

The use of adobe as a building material is very common in some sections of Colorado, especially in the dryland regions. Its use is not restricted to the construction of farm buildings only, for many town and city residences are made of adobe. The sugar companies have used adobe very extensively in the last few years in the construction of colony houses for their beet workers. The houses are built by the workers in spare time between beet tendings.

In the summer of 1910 some buildings were constructed of adobe at the Cheyenne Wells sub-station of the Colorado Experiment Station. The construction of these buildings is explained in Colorado Bulletin 174. The walls were of the "cob" type, that is, they were built up of wet adobe in sections, as a solid wall. Each layer was dried sufficiently to stand up before the following layer was added.

Two disadvantages to this type may be mentioned. Only a small portion of the wall can be built in a day because the adobe must have time to dry so that it will stand up. Consequently, the process of building is a slow one. The other objection is that the wall settles somewhat in curing and difficulty is experienced in getting the door and window frames to fit tightly in the wall.

Another method is in use in some sections of the state called "poured earth." Natural earth is mixed with water to make a plastic mud and then poured into forms similar to those used in concrete construction. One advantage in this type of construction is that the earth is handled but once. In the last few years these methods of construction have been replaced by molding the adobe into bricks and then making the walls of the cured bricks.

This bulletin describes a simple method of making adobe bricks and of laying them in the wall.

## ADVANTAGES OF ADOBE BRICK AS A BUILDING MATERIAL

The adobe brick is used as a building material in the plains section of Colorado mainly because of its cheapness. Where the soil will permit the making of adobe the farmer can do the construction himself with ordinary farm help. He can work at this when his other work is slack. A building made of adobe is cooler in summer and warmer in winter than the ordinary frame building. Where the roof is well made and the foundation protected from washing, the adobe building will last for years. Those constructed at Cheyenne Wells in 1910 are in good condition today.

Figure 8 shows a barn in Rocky Ford that has been used over forty years. The adobe can be made into neat-appearing buildings, as is shown by figure 1.

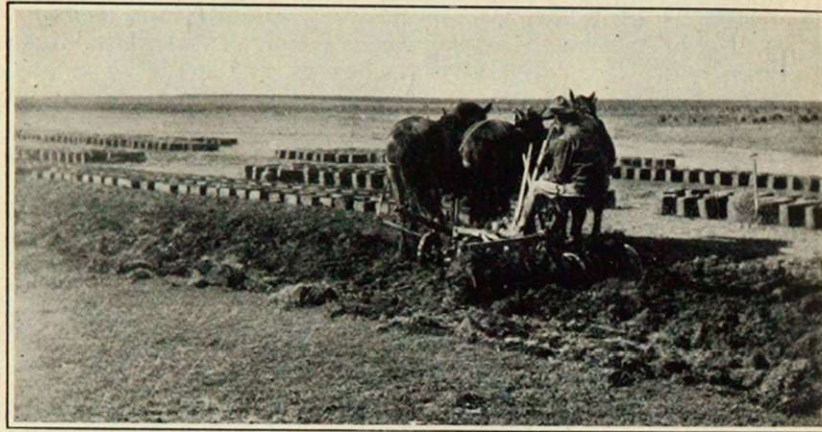


Figure 2. Working the soil with disc. Bricks tilted on edge in background

#### TYPE OF SOIL

The construction of adobe requires a soil that contains a great deal of clay. Not all clay soils, however, will make good adobe brick. In some sections of Colorado the native sod will make the best brick, while in other sections it is necessary to remove the black surface soil and use the lighter-colored subsoil. Care should be taken not to use soils that have been washed into ravines and other low places, as these usually contain too much silt. Some soils will make adobe bricks which look well when new, but if these are exposed to the air for several weeks they commence to crumble. The best way, therefore, to determine whether or not a soil is adapted to the making of good adobe brick, is to make a few bricks and allow them to cure in the open air, protected from rain and other moisture. If they stand up after curing two months or longer without crumbling, the soil can be used for adobe construction without much danger.

#### MIXING THE SOIL

Select a patch of prairie where the grass is thick and tall. With a sod plow, plow a thin sod, about three or four inches in thickness. A strip large enough for the entire building may be plowed at one time if desired, but a strip large enough for a day's work should be puddled each day. Disk the sod with an ordinary disk harrow, adding water to the soil gradually until it becomes too wet or mucky to work with the disk. Some

farmers use a cultivator instead of a disk. The soil is then further mixed by driving or leading horses back and forth over the wet soil. Sometimes it is puddled by men tramping it with bare feet, or by the use of a mortar hoe. Water must be added until the adobe is plastic and can be handled with a six-tined manure fork. It must, however, be stiff enough to stand up when the form is removed. The thoroly-mixing-and-puddling process is perhaps the most important in making adobe brick.

Sometimes native prairie sod is not available, and soil without the fiber or binding material must be used. Suitable soil is chosen and the ground plowed. If the soil contains a great deal of decaying vegetable matter it is advisable to remove the surface soil to a depth of six or eight inches. After the ground has been plowed or spaded it is worked, and water added as explained above. After it has been well puddled a binding material must be added. Fiber or binding material makes the brick less likely to crack when curing. It reduces the action of water on the brick when placed in the wall, and it makes the brick somewhat stronger and more durable.

Straw and chaff are perhaps the most commonly used binding materials in this state. The shorter the straw the better it is for this purpose. Cut straw is best. When straw is used enough should be added to make a good brick. Usually a layer of two inches of straw on a layer of mud three to four inches in thickness makes a brick with sufficient binding material, but soils vary so that no rule should be followed too closely. The straw should be worked into the mud thoroly. If the straw is added before any mixing is done care should be taken to prevent it from being worked to the bottom.

### MAKING THE BRICK

The size of bricks varies with the type and size of building for which they are to be used. For smaller buildings, such as chicken houses, milk houses, calf sheds, etc., the bricks are usually made 5x10x20 inches. These make a ten-inch wall. A brick 6x12x24 inches is sometimes made, but this brick is very heavy in weight and difficult to handle. Dwellings are sometimes made with walls 16 inches in thickness, the bricks being 5x12x16 inches in size.

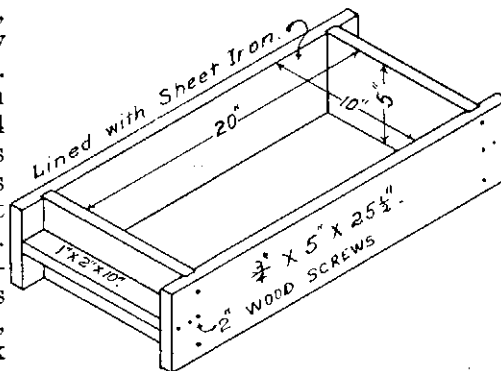


Figure 3. Form for making adobe brick



Figure 4. Puddling the adobe with horses.



Figure 5. Molding the bricks. Notice how the bricks are molded in rows, and the position of the molds.

The mold is made of soft pine, the inside dimensions being the same size as the desired brick. Figure 3 shows the construction of a form for making one brick at a time. It can be built to make two or three bricks at a time, altho the desirable size is either one or two bricks. The form is sometimes lined with sheet iron which prevents the mud from adhering to the sides as readily as on wood.

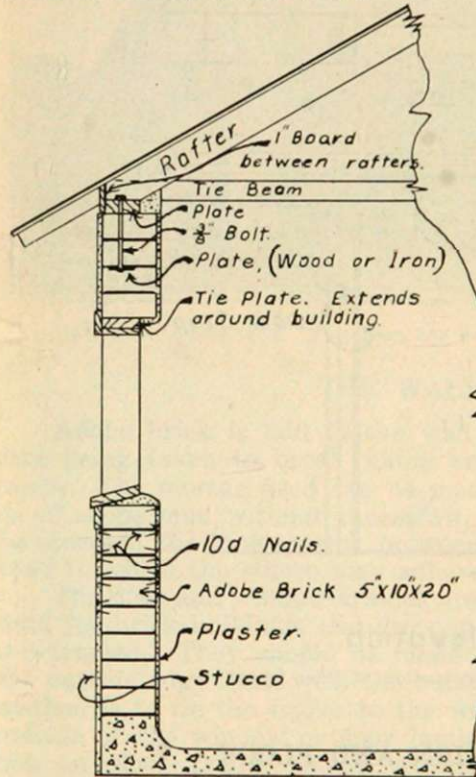


Figure 6. Detail plan showing the construction of an adobe brick wall.

The mud, after it is thoroly puddled, is placed in the form by means of a six-tined fork. The molder presses the mud into the corners of the mold with a tamper, with his fists, or tramps it in place with his feet, and smoothes off the top with a trowel. The mold is lifted off and refilled. One difficulty which occurs when raising the form is the sticking of the mud to its sides. This can be reduced to a minimum by having a pail of water and a brush at hand, and dampening the sides of the mold after each brick is removed.

The native buffalo-grass sod makes a very good molding floor. Where it is impossible to secure such a place, a good floor is made by leveling off a piece of

ground and placing straw over the surface. The straw prevents dust and dirt from adhering to the wet brick and saves a great deal of time in trimming.

### CURING

After the bricks are molded they are allowed to dry one or two days, depending on the weather. The bricks are then tilted on edge and allowed to dry. When dry enough to handle, usually in about a week, they are placed in piles so the air can circulate around them. The usual method is to pile them on

edge, at an angle to each other, as shown in figure 9. The piles should be protected from rain, as water will cause the bricks to become soft and to crumble. Adobe bricks should not be exposed to frost before they are properly cured. Freezing tends to soften them and thus causes them to crumble.

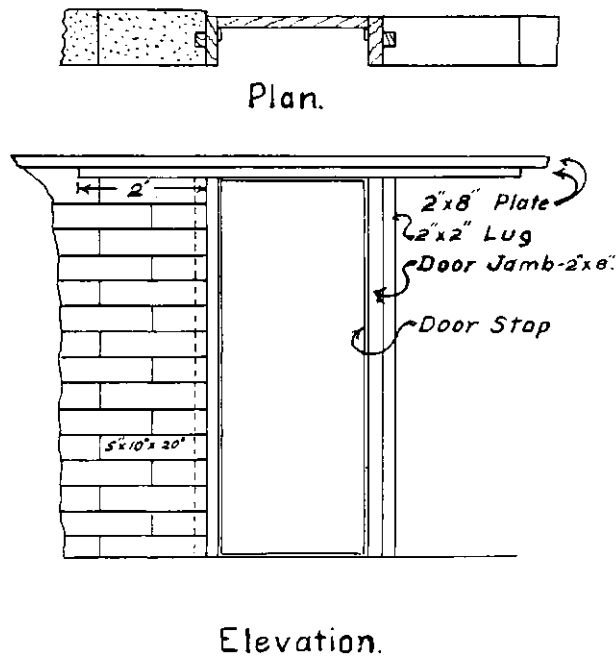


Figure 7. Construction of door frame.

### FOUNDATION AND FLOOR

The life of an adobe building depends to a large extent upon its roof and its foundation. The foundation is usually made of concrete and should extend above the ground high enough to prevent the wall from becoming wet from splash during rains. For ordinary farm buildings a height of twelve inches above ground is sufficient.

Adobe is sometimes used as a foundation, but the splash from rains and the action of the wind tends to erode it badly and decreases the life of the building. The slope of the ground should be such that all water will run away from the building. The floor in a dairy or horse barn should be below the top of the foundation to prevent the splash in washing the floor from moistening the wall.



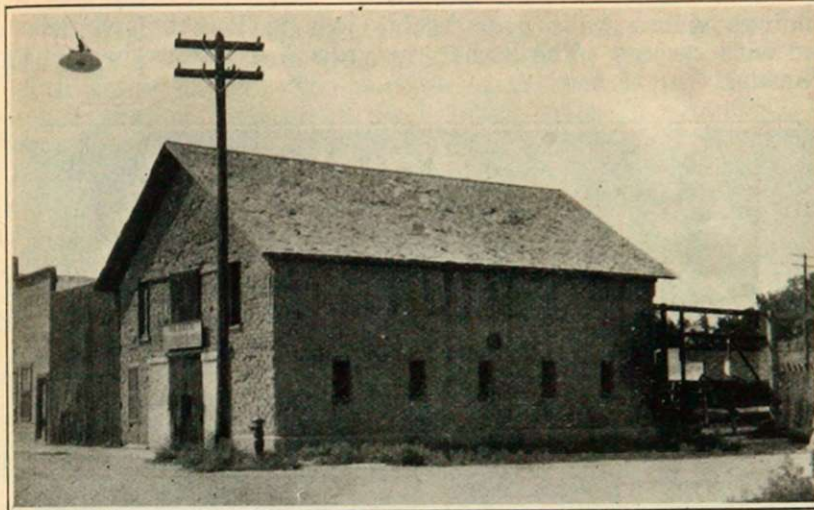


Figure 8. Adobe barn. This barn has been in use over forty years.

### THE WALLS

Adobe brick is laid in the wall as ordinary brick is laid, care being taken to break joints and to get the corners well made. The mortar used can be made either of lime and sand or of adobe mud without the straw. If the outside wall is to be stuccoed the lime mortar between the bricks gives a better bond to which the stucco may adhere, but it is more expensive.

The door and window frames are of the same type as those used for brick buildings and are put in place before the wall is constructed. They should be made of two-inch material, with the outside edge flush with the outside wall line. The common method is to tie the frame to the wall by placing a lug on the outside of the window or door jamb. The top piece of a window or door frame should extend beyond the sides from eighteen to twenty-four inches. Figure 7 shows a common type of construction. Care must be taken to get the space between the brick and the frame well filled with mud or mortar to shut out wind and water.

Some adobe builders make a practice of placing the tops of the doors and windows at the same height. A plate, usually of two-inch material, properly tied together, is then placed above the doors and windows and around the entire building. This plate prevents uneven settling and helps to tie the walls together. In laying the bricks in the wall care should be taken to fill all spaces between the bricks with mud or mortar. The maximum height of adobe walls is commonly understood to be twelve feet, with nine feet as the ordinary height. There are

buildings where walls over twelve feet in height have been used with success. The higher the walls the thicker they must be made.

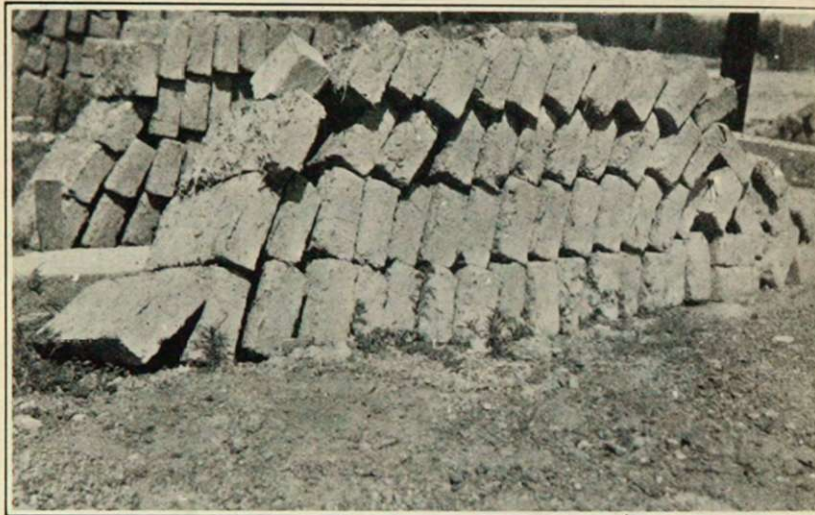


Figure 9. Method used in piling adobe brick for curing.

### THE ROOF

Different types of roofs are employed. At Cheyenne Wells a variety of roofs has been used: Galvanized iron, prepared roofing, shingles, and roof cement. Where galvanized iron is used on buildings housing animals, it should have sheathing underneath. The iron roofing itself makes the building warm in summer and cold in winter, especially where the structure is a one story type. In winter, moisture from the breath of the animals will condense and collect on the roof, causing frost to form in cold weather. This moisture will also tend to cause the iron to rust. An adobe building with an iron roof is practically fireproof. Shingle roofs are very common on adobe buildings and are very durable, but are not fireproof.

The roof is held in place by bolting the plate to the wall about every six feet. The end of the bolt is held in the wall by means of a small wooden or iron plate placed between the layers of brick. Some builders bore a hole in the top of the finished wall with a two-inch soil auger to a depth of 12 or 14 inches. A bolt is placed in this hole, allowing it to extend above the wall far enough to go thru the plate. The holes are then filled with concrete and allowed to set before the plate is fastened.

On buildings with flat roofs the common roofing material is either sheet iron or prepared roofing, on top of which sod or adobe is placed. The purpose of the sod is to absorb the sun's rays and thus make the building cooler in summer.

The roof should extend outside of the wall line far enough to prevent the drip water from splashing onto the wall. An overhang of from 12 to 18 inches is usually sufficient, depending upon the size of roof and height of wall. Where flat roofs are used, galvanized pipes extend out from the roof about three feet from the wall and drain the water far enough from the wall to largely prevent washing from splashing.

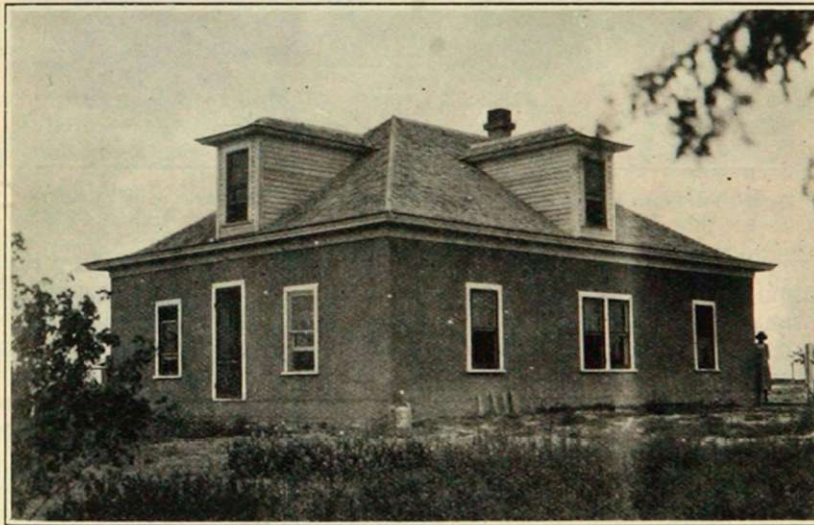


Figure 10. Adobe farm house. Stuccoed on the outside

#### OUTSIDE FINISH

The life of an adobe building is lengthened and the looks improved by giving the outside walls a coat of stucco. One of the difficulties in putting a coat on the outside of an adobe building seems to be its cracking. This may be reduced to a minimum by putting either chicken or rabbit netting on the wall before plastering. The netting is nailed to the adobe wall and then stuccoed. Another method commonly used consists of driving 8d or 10d nails into the wall, two or more to the block. The heads of the nails are allowed to extend out far enough so that they will hold the plaster and yet be covered. About one-eighth of an inch would be approximately the correct distance. The nails should be driven in at an angle to each other to make pulling out more difficult. Cracking is

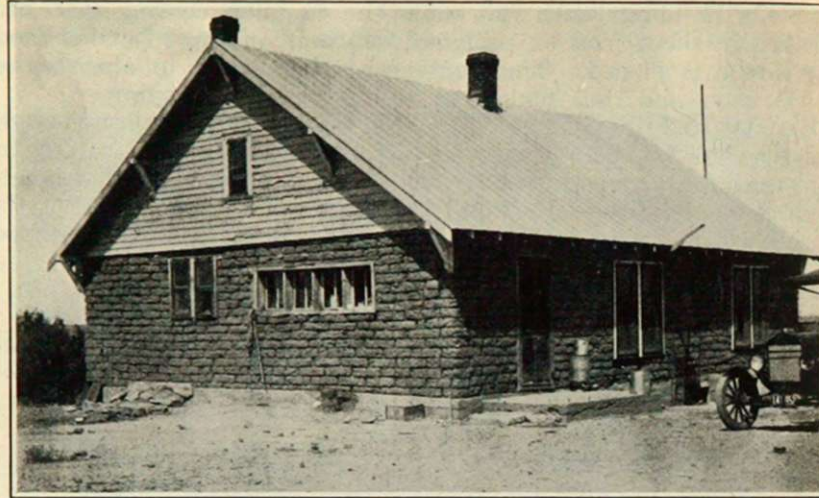


Figure 11. Farm house built of adobe brick. The gables are made of lumber.

sometimes caused by the stucco drying out too fast after it is applied. This is difficult to prevent. If the adobe brick will stand water it is well to moisten them before applying the stucco and then sprinkle water on the stucco frequently when curing. A good Portland cement stucco is made by mixing one part of cement with two and one-half parts of clean sand and lime putty, equal to about one-third of the volume of the ce-



Figure 12. Adobe hut. Notice the sod roof.

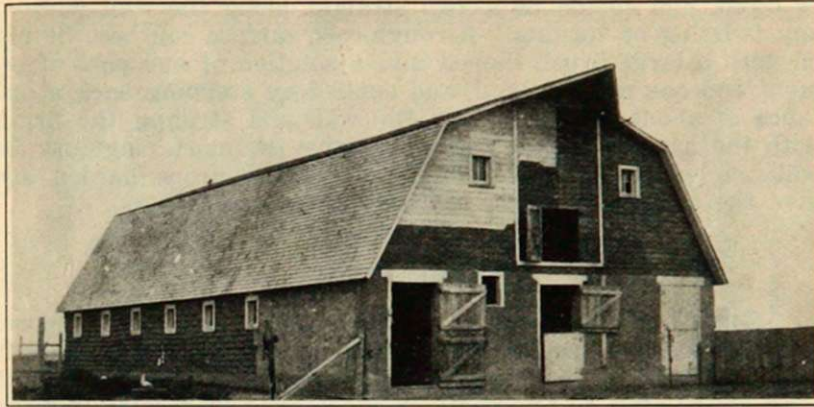


Figure 13. Barn built of adobe brick. A portion of the wall has been stuccoed.

ment. Hydrated lime may be used instead of lime putty at the rate of one-tenth the weight of cement. These materials are thoroly mixed and enough water added to secure the correct consistency, which can be determined after a little experimenting in application. The more common stucco finishes are: Smooth-troweled, pebble-dash, sand-floated, and rough-cast. Of these the smooth-troweled and the rough-cast are perhaps the most extensively used on adobe buildings. For the former method floats should be made of a close-grained wood such as beech

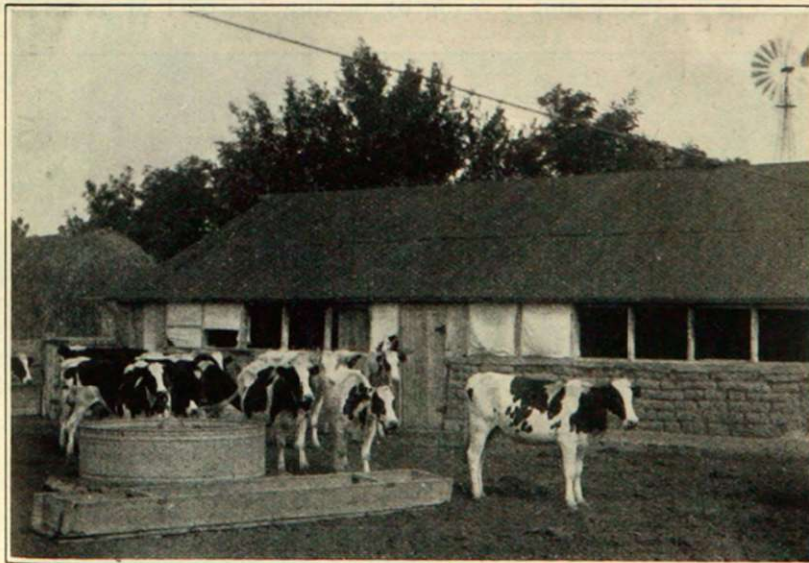


Figure 14. Cow barn constructed of adobe brick.

or birch, and should be drawn straight along the wall without any twisting or turning. A rough-cast surface can best be put on with a large brush dipped into a solution of one part of cement and one part of sand, and applied by stepping back a distance of about two feet from the wall and striking the brush with the hand in such a way as to drive the mortar against the wall, on which it collects in drops. These drops harden and give the surface a rough, pleasing appearance.

### INSIDE FINISH

Some buildings such as poultry houses and dairy houses are plastered on the inside. A plaster which is easy to apply and does not cost a great deal is made by mixing one part of sand, by volume, to two parts of adobe soil. A mortar is made of this mixture and applied to the wall with an ordinary trowel. This plaster is durable if kept dry but will not withstand moisture. Sometimes a thin coat of lime or cement plaster is applied to the wall after the mud plaster has dried sufficiently to be hard. The purpose of the mud plaster is to fill up the uneven spaces in the wall, and the lime or cement plaster gives it permanency. Before applying the plaster it is well to drive nails in the wall as described for outside plaster. Residences should be plastered with nothing but a good lime or a cement plaster. Patent plaster is now used almost exclusively for inside work and must be applied according to directions. For buildings other than residences, a lime mortar is sometimes used as a plaster and is made by mixing one part of quick lime



Figure 28. The walls of this root cellar are made of adobe brick and stuccoed.

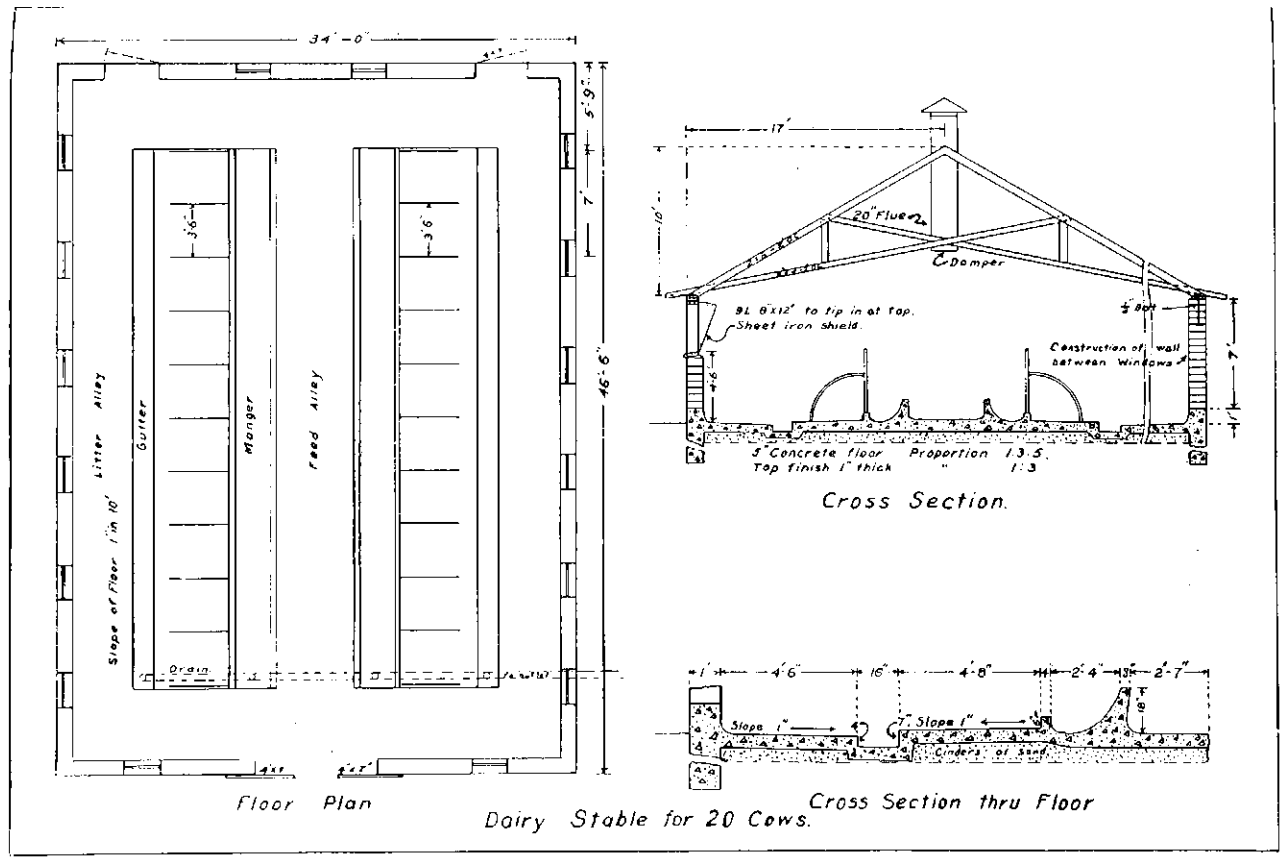


Figure 15. Floor plan of dairy stable for twenty cows.

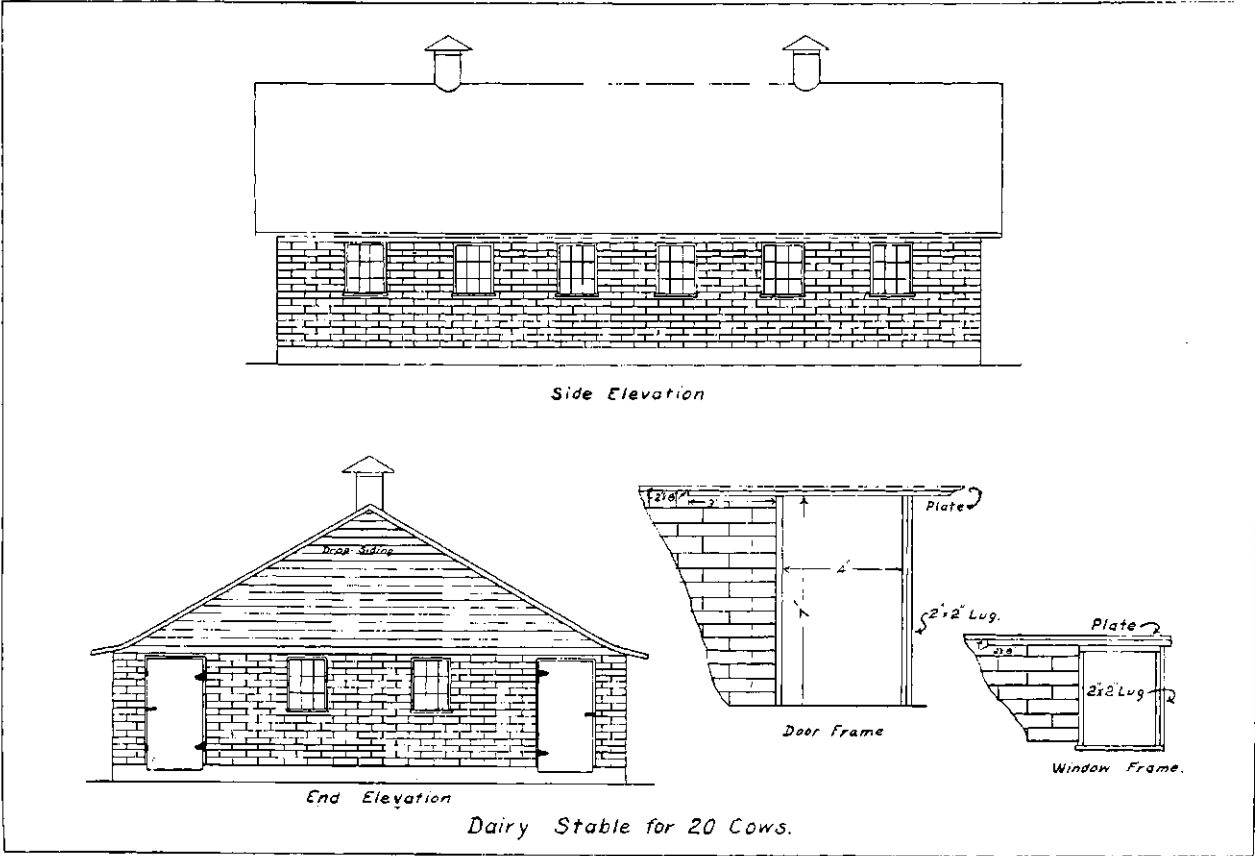


Figure 16. Side and end elevation of dairy stable for twenty cows.





Figure 17. Adobe chicken house. Makes a house warm in winter and cool in summer.

by weight, with three parts of sand. The quick lime must be properly slacked before it is mixed with the sand. Sometimes hair is added as a binder.

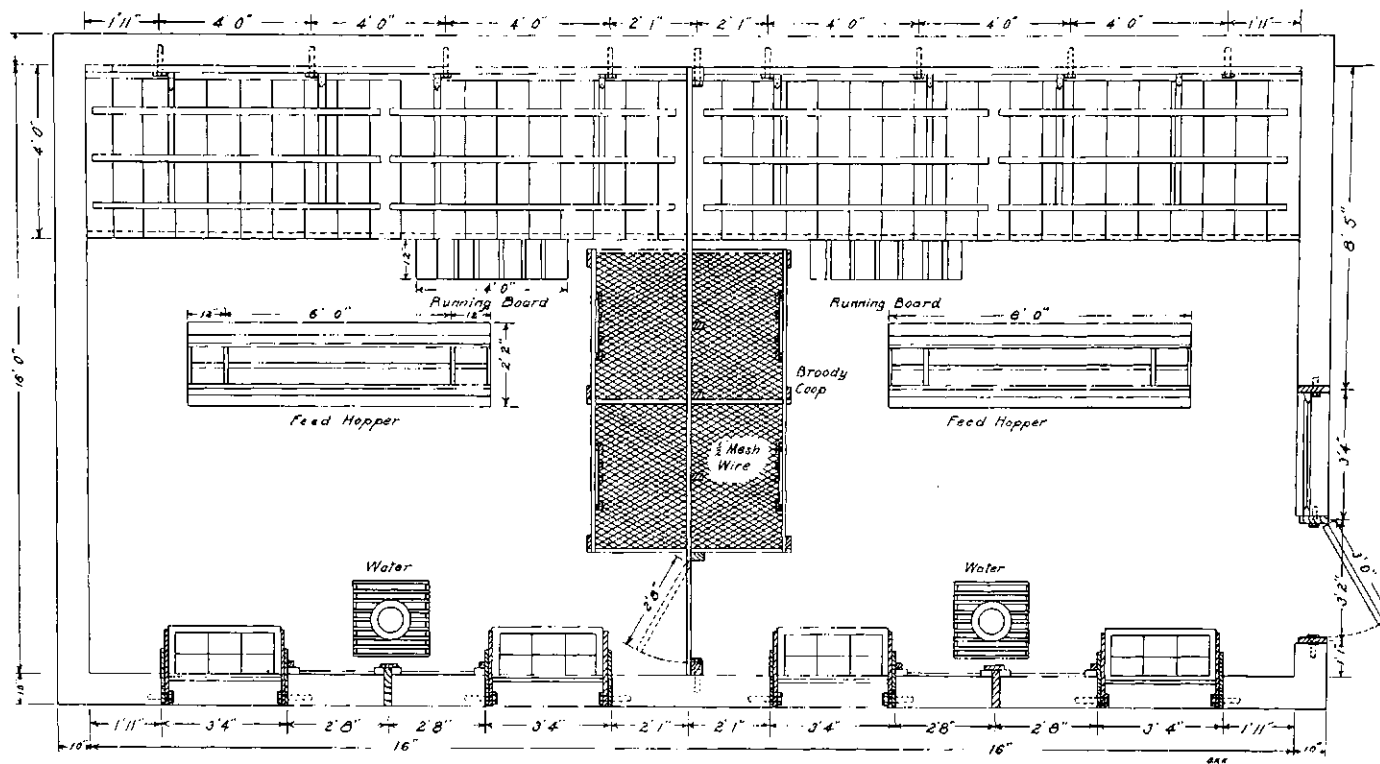
#### COST DATA

One of the advantages of adobe brick is that it can be made on the farm without skilled help. The number of bricks a man can make depends upon the size and upon his proficiency as a workman. At Cheyenne Wells three men worked together, making on the average one hundred bricks per man per ten-hour day. A man can usually lay between 100 and 150 bricks per day, depending upon the care taken in laying.

Some farmers hire brick made and the price varies with localities. The range extends between \$25 to \$35 per 1,000 brick, depending upon the size.

#### SUMMARY

- (1) Adobe is used as a building material in many sections of Colorado.
- (2) Three methods of construction are used: the "cob", the poured earth, and the adobe brick. The adobe brick is the method most extensively used in Colorado.
- (3) A soil containing a large amount of clay is essential in good adobe construction. All clayey soils do not make good adobe brick. The soil should be tested by making



FLOOR PLAN

Figure 18. Floor plan to accommodate 150 chickens.

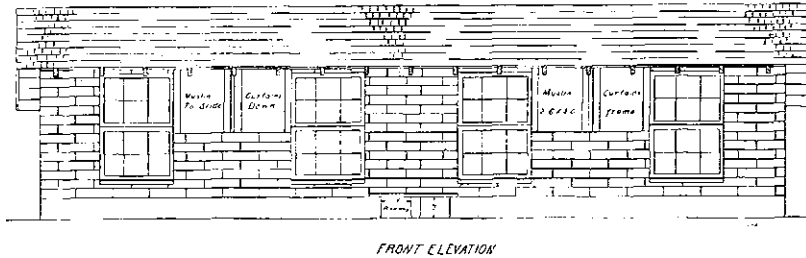


Figure 19. Front elevation of chicken house

two or three bricks a few months before the building process is to commence.

- (4) Select native prairie sod of correct texture, if available. The grass and roots furnish the binding material. If sod cannot be obtained, ordinary clay soil may be used. The binding material must be added in the form of cut straw or chaff.
- (5) Puddle the soil thoroly and add water enough to make a mud easily handled with a six-tined fork and yet stiff enough to retain its shape when form is removed.
- (6) A good molding floor is desirable.
- (7) The brick must be properly cured before it is placed in the wall.
- (8) Protect the brick from moisture and frost while curing.
- (9) The foundation should extend above the surface of the ground to prevent water from coming in contact with the walls.

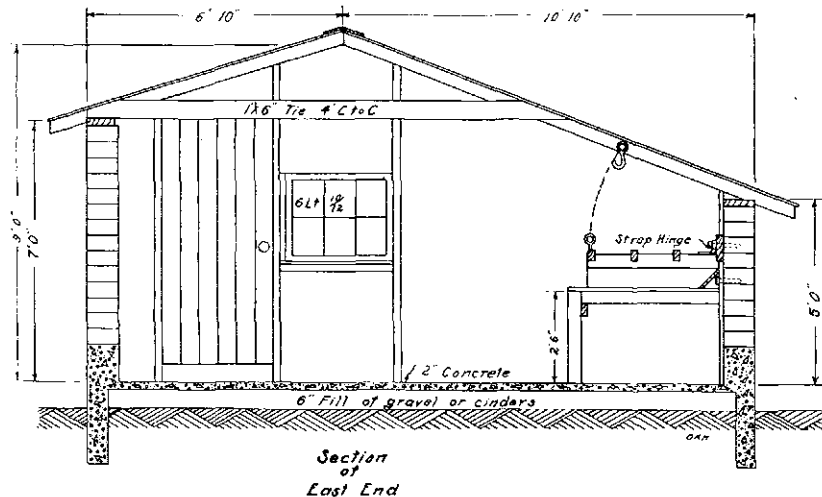


Figure 20. East end section chicken house.

- (10) A good roof is essential to a good adobe structure.
- (11) The life of an adobe building may be increased and the appearance improved by the application of a cement stucco.
- (12) Adobe brick make a wall that is practically air-proof and, therefore, make a building that is cool in summer and warm in winter.
- (13) Another advantage of the adobe brick is that farm labor can make it at odd times when other work is not pressing.

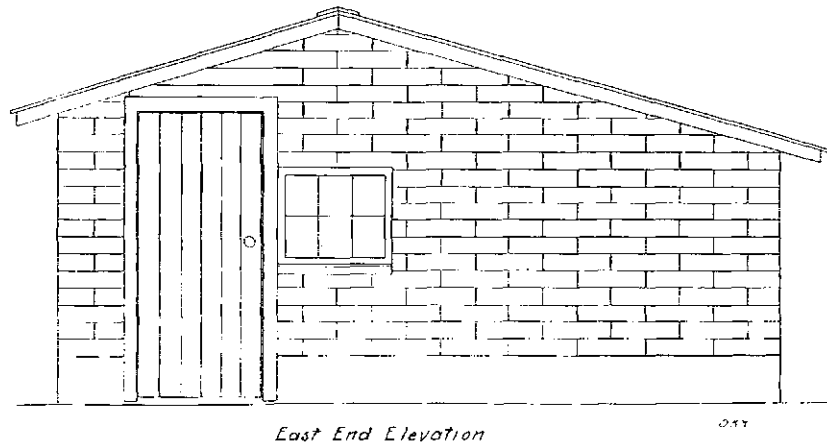


Figure 21. East end elevation of chicken house.

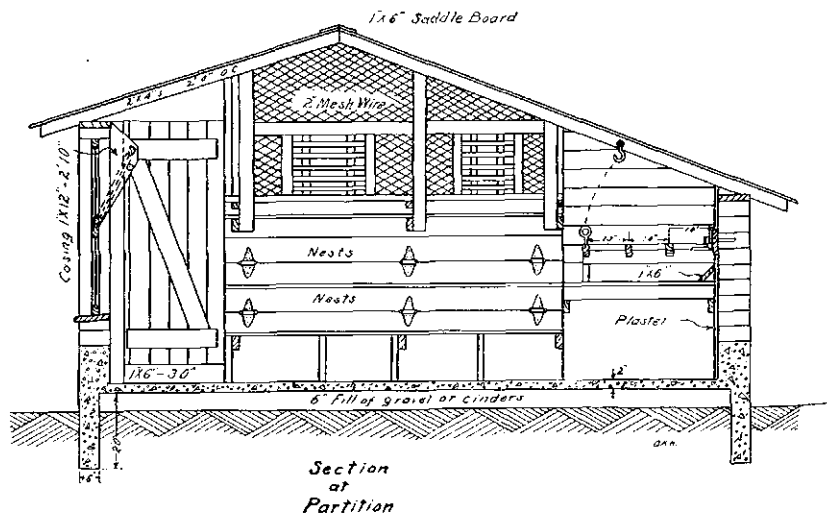


Figure 22. Section at partition of chicken house

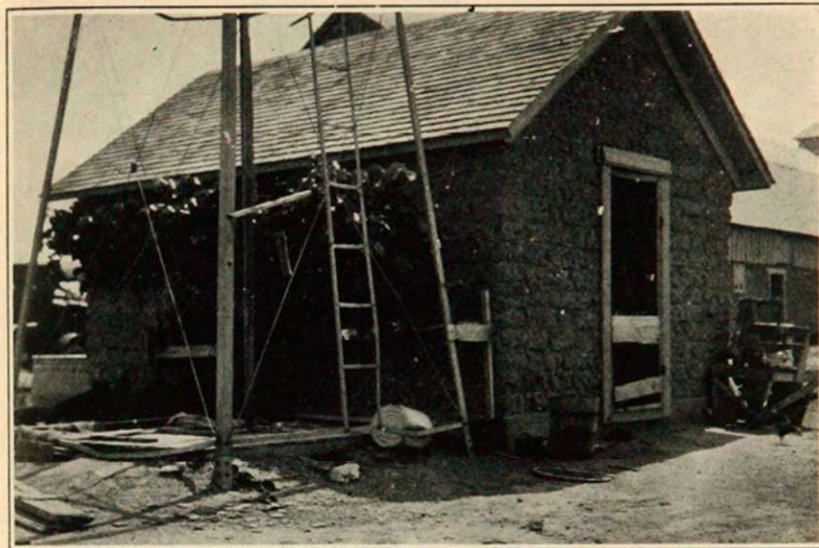


Figure 23. Milk house built of adobe brick.

### COST ESTIMATING

One of the most difficult and yet one of the most important questions that confronts the prospective builder is that of cost. A few suggestions may be of value in estimating the cost. A definite order should be followed in estimating to avoid the possibility of omissions. The following order is suggested for the ordinary farm building:

- |               |                   |
|---------------|-------------------|
| 1. Foundation | 5. Outside finish |
| 2. Floor      | 6. Inside finish  |
| 3. Walls      | 7. Hardware       |
| 4. Roof       | 8. Painting       |

**Foundation.**—This division includes the labor and the materials for the footings, foundation, and other masonry work connected with the foundation. Concrete is usually measured by the cubic yard, and the sand and gravel determined. A mixture of 1 part cement,  $2\frac{1}{2}$  parts sand, and 5 of gravel will give sufficient strength for ordinary foundations.

Where large rocks are available they may be placed in the foundation and thus cheapen the construction without weakening the structure. The following table gives the amount of material needed for one cubic yard of concrete of different proportions.

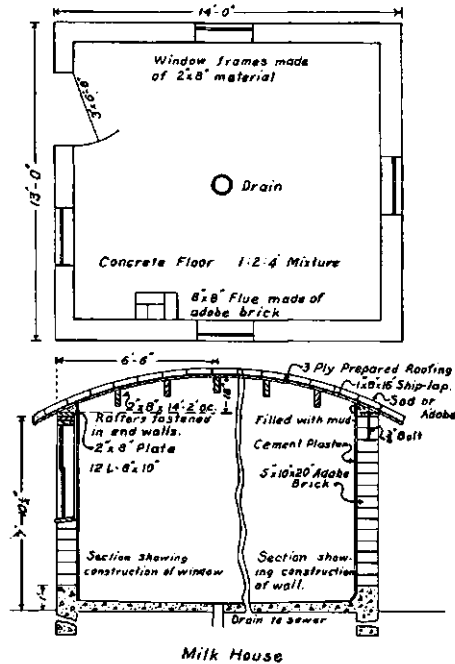


Figure 24. Interior of milk house— floor plan and section

## MATERIAL FOR ONE CUBIC YARD OF CONCRETE

Mixture	Cement Bags	Sand Cu. Ft.	Gravel Cu. Ft.
1:1½	15.45	23.2	
1:2	12.48	25.6	
1:3	9.56	28.6	
1:2:3	6.96	14.0	20.8
1:2:4	6.04	12.2	24.0
1:2½:5	4.96	12.4	24.8

**Floor.**—The floor includes all the joists, flooring, and labor.

**Roof.**—The roof includes plate, rafters, sheathing, tie beams, roof covering, and labor in putting roof on. Roofing is usually estimated by the square which contains 100 square feet.

**Walls.**—The walls include the cost of making adobe bricks, the labor in laying them, and the mortar, if other than mud is used. Doors, windows, frames, and lumber in gables should also be included as well as all labor in erecting.

**Plastering.**—The outside and inside finish should include the material used in plaster, stucco, and the labor in putting the material on the walls. If the ceiling is to be plastered, the additional material necessary for such work should be included.

**Hardware.**—Hardware includes nails, netting, tinwork, gutters, door and window hardware, and any other special equipment, such as stanchions and ventilators.

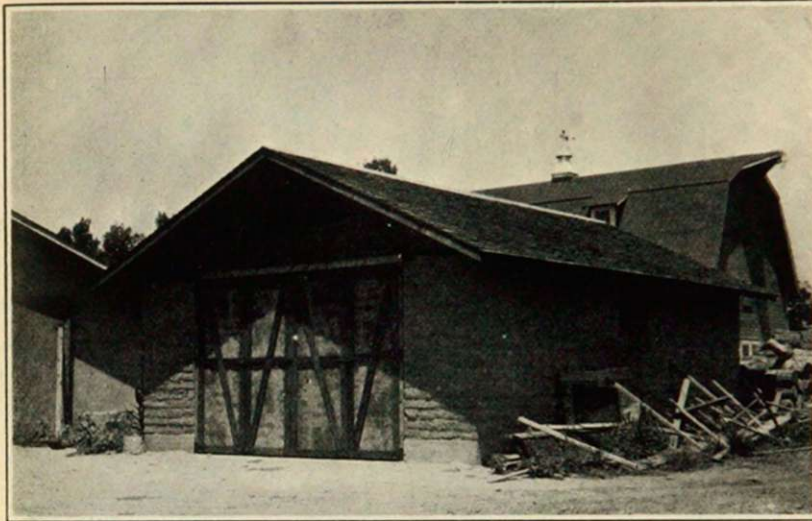


Figure 25. Garage built of adobe brick.

**Paint.**—Altho the walls of adobe houses need not be painted, there are portions such as gables, trimming and roof that need paint. Paint is usually measured by the square yard, a gallon covering between 40 and 50 square yards. The labor in painting should be included. A good painter will paint between 80 and 100 square yards per day.

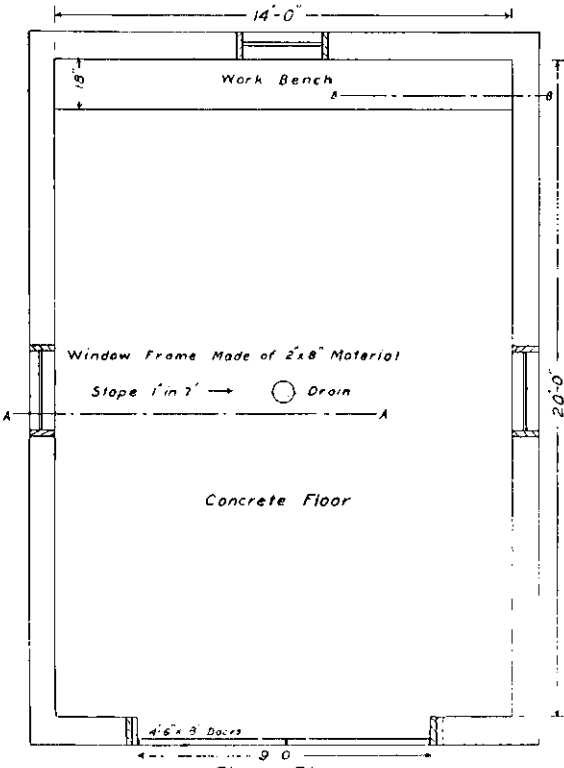
#### ACKNOWLEDGMENT

The authors wish to acknowledge their indebtedness to Professor Alvin Kezer and Mr. P. K. Blinn for valuable assistance in the preparation of this bulletin.

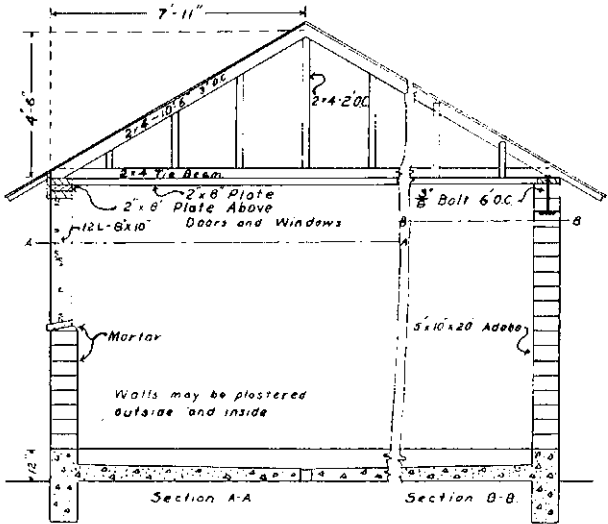


Figure 27. Machine shed made of adobe brick.

Garage for One Car



Floor Plan



Cross-Section

Figure 26. Floor plan and cross section of garage for one car.