

**THE COLORADO SATELLITE-LINKED
WATER RESOURCES MONITORING
SYSTEM**

**ANNUAL STATUS REPORT
F Y 1987-88
3RD EDITION**

EDITED BY: JOHN R. KALISZEWSKI
PROJECT MANAGER

**OFFICE OF THE STATE ENGINEER
DIVISION OF WATER RESOURCES**

Roy Romer
Governor



Jeris A. Danielson
State Engineer



OFFICE OF THE STATE ENGINEER
DIVISION OF WATER RESOURCES

1313 Sherman Street-Room 818
Denver, Colorado 80203
(303) 866-3581

I am pleased to release the FY 1987-88 Annual Status Report of the Colorado Satellite-Linked Water Resources Monitoring System. The report addresses all aspects of the monitoring system including examples of system utilization for all seven major drainage basins in the state of Colorado. After just three full years of operation, the system has proven to be a highly effective tool in the management of our precious water resources.

There are several key aspects of the system that I would like to point out:

- The system provides cost benefits estimated to be \$1.5 million annually. Benefits-to-cost-ratio is approximately 6 to 1.
- The system is a public system with access available to all Colorado water users.
- The system can be easily expanded with additional monitoring stations and additional sensor types.
- The system has received national merit awards from the Council of State Governments and the National Society of Professional Engineers for innovation and design. The state of Colorado remains on the leading edge of technology in this area.

One critical area of concern that needs to be addressed is funding. The State Legislature appropriated from the General Fund \$94,369 for operation of the system in FY 1987-88. The remainder of the \$228,341 budget was to be collected from user fees. Insufficient user fees were collected resulting in a \$40,609 underfunding. This had an impact on the operation of the system. A budget proposal submitted to the Joint Budget Committee requesting that the General Fund appropriation be increased to \$155,525.00 for FY 1988-89 was denied.

It is the consensus of this office and the water user community statewide that water rights administration is the responsibility of the State and should be funded accordingly. A budget proposal requesting increased General Funding will be submitted by this office for FY 1989-90.



Jeris A. Danielson
State Engineer

TABLE OF CONTENTS

	<u>Page</u>
INTRODUCTION.	1
SELECTED REMARKS ON THE SATELLITE MONITORING SYSTEM	3
PROJECT MANAGER'S REPORT.	5
SYSTEM PROGRAM MANAGEMENT AND SUPPORT STAFF ORGANIZATION CHART.	11
I. PROGRAM DESCRIPTION	
A. System Configuration	13
B. System Operations.	15
C. System Software.	19
D. System Capabilities.	20
E. Future System Developments	21
F. Monitoring System Network.	24
Table 1, Satellite-Linked Data Collection Network.	27
Figure 1, Monitoring System Configuration.	37
Figure 2, GOES Satellite Receive Site Electronics.	39
Figure 3, VAX 11/750 Computer and Communications Hardware.	41
Figure 4, DWR Data Management System	43
Figure 5, DAYFILES Report.	45
Figure 6, ARCHIVES Report.	47
Figure 7, ANNUAL Report.	49
Figure 8, DAYFILES Plot.	51
Figure 9, ARCHIVES Plot.	51
Figure 10, ANNUAL Plot	51
Figure 11, SCHEMATIC	53
II. SYSTEM APPLICATIONS	
A. Water Rights Administration.	55
B. Hydrologic Records Development	56
C. Water Resources Accounting	57
D. Dam Safety	57
E. Automated Flood Warning System	57
F. Future Applications.	59
Table 2, Satellite Monitoring System Flood Warning Network	61
III. OPERATING BUDGET	
A. FY 87-88 Operating Costs	65
B. FY 88-89 and FY 89-90 Budgets.	66
C. Future Budget Considerations	66
Table 3, FY 87-88 Budget	67
Table 4, FY 88-89 and FY 89-90 Budgets	68

TABLE OF CONTENTS
(Continued)

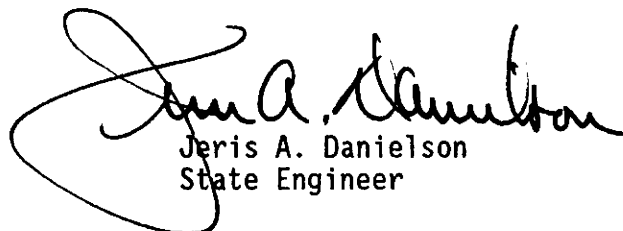
	<u>Page</u>
IV. FUNDING SOURCES	
A. FY 87-88 Funding	69
B. FY 88-89 Funding	70
C. FY 89-90 Funding	70
D. User Fee Requirements by Division.	70
E. Future Funding Considerations	71
V. COST-BENEFIT CRITERIA.	73
VI. EFFECTS OF LOSS OF FUNDING FOR FY 88-89.	75
VII. SYSTEM USERS	
A. Office of the State Engineer	77
B. Water Conservancy Districts.	77
C. Municipalities	77
D. State Agencies	77
E. Federal Agencies	78
F. Associations	78
G. Private Entities	78
VIII. UTILITY OF THE SATELLITE-LINKED MONITORING SYSTEM WITHIN THE COLORADO DIVISION OF WATER RESOURCES	
NARRATIVE AND SPECIFIC APPLICATION EXAMPLES	
A. Division 1, South Platte River Basin	79
B. Division 2, Arkansas River Basin	93
C. Division 3, Rio Grande Basin	105
D. Division 4, Gunnison River Basin	115
E. Division 5, Colorado River Basin	125
F. Division 6, White/Yampa River Basin.	133
G. Division 7, San Juan and Dolores River Basins.	139
H. Flood Monitoring Utilizing Real-Time Data.	149
I. Dam Safety Monitoring Utilizing Real-Time Data	151
J. Historic Flow Data	153
IX. DEFINITION OF TERMS.	155
APPENDIX A	159
APPENDIX B	161

INTRODUCTION

The Colorado satellite-linked monitoring system provides real-time water resources data on a continuous basis from key gaging stations across the state of Colorado. The computerized system can be accessed by computer terminal or by phone from any location via phone communications. These data and appropriate applications software provide for more effective water rights administration, computerized hydrologic records development, flood warning, and water resources management.

The system was provided to the State Engineer by the Colorado Water Resources and Power Development Authority pursuant to Section 37-95-107(5), C.R.S. (1983), by enactment of Senate Joint Resolution No. 20. The Authority's Board was convinced through a two-year demonstration project in the Arkansas River and Rio Grande basins that the system could be an important tool in water resources management. Since the enhancement of water resources management is one of its goals, the Authority elected to fund the installation of the system and its first year (FY 84-85) of operation at a total cost of \$1.8 million.

The Authority awarded the contract, under competitive procurement, to the Sutron Corporation, Herndon, Virginia, in May, 1984. The original contract called for Sutron to provide a turn-key system including remote data collection hardware for 82 stations, receive site, central computer, and operating/applications software. In March 1985, the Authority approved an expansion of the monitoring network by an additional 68 stations. This effectively brought the statewide network to 150 stations. The system acceptance test was successfully run on August 8, 1985. The system was formally dedicated on October 4, 1985. At that time, the Authority turned the system over to the state of Colorado under the jurisdiction of the Office of the State Engineer.

The Colorado satellite-linked water resources monitoring system received national merit awards in 1985 and 1986. The National Society of Professional Engineers selected the system as one of ten outstanding national engineering achievements for 1985. The Council of State Governments selected the system as one of eight of the top innovative programs instituted by state government in the nation for 1986. Colorado remains the only state in the nation to operate a statewide monitoring system of this type. Colorado remains in the forefront in utilization of this technology with other western states in the planning process to install and operate similar systems. These states include Utah, Texas, California, Idaho, Washington, Arizona, New Mexico, and Hawaii.

The interest in real-time data collection for monitoring water resources and other natural resources data is growing at an incredible rate due to the need for such data and the cost effectiveness. Various federal agencies, water conservancy districts, municipalities, and private entities now operate over 130 satellite-linked data collection stations in Colorado in addition to the state operated network.

SELECTED REMARKS ON THE SATELLITE MONITORING SYSTEM

"Colorado feels a hard-earned sense of pride that its satellite-linked water resources monitoring system was named one of the nation's ten best engineering achievements in 1985. In 1986, the Council of State Governments has honored this system by citing the satellite-linked monitoring program in Colorado in its national monthly publication of featured articles, INNOVATIONS. I think most of all, that the water scarce state of Colorado comes closer to not wasting a precious drop of water than any similar sized water management area in the world."

State Senator Harold McCormick
District 4, Canon City, Colorado

"Water resource management can only be accomplished by correct and timely measurements, and the state of Colorado excels in that endeavor as a result of the satellite stream gauging program which is now available to water users throughout the state. Accurate electronic measurements can be made at strategic locations throughout the state to anticipate flooding conditions or deliver minute quantities of water to be put to beneficial use. Water managers in the state are actually able to operate under 21st Century programs."

Charles L. (Tommy) Thomson, General Manager
Southeastern Colorado Water Conservancy District

"Colorado should proceed directly ahead with enhancing the capabilities of the satellite-linked water resources monitoring system. This includes monitoring basic water quality parameters such as conductivity, water temperature and dissolved oxygen. These are especially important at reservoirs and for reservoir releases. The state needs to expand both short-term and long-term runoff forecasting capabilities. This will prove to be critical when the state experiences periods of less than normal water supplies. The ability to monitor on a real-time basis parameters such as water equivalency in snowpack, rain events, and soil moisture can provide forecast information that can help predict shortages and make agricultural water leasing a possibility. The system must become a water management tool rather than just an administrative tool."

Uli Kappus, Executive Director
Colorado Water Resources and Power Development Authority

"The Colorado satellite-linked water resources monitoring system has been very effective in helping the National Weather Service discharge its responsibilities relative to the dissemination of flood warnings. The River Forecast Centers are responsible for making streamflow forecast throughout the country. The four Centers serving Colorado have access to real-time data on the most important streams in Colorado on which to base their forecasts. This is not true of the surrounding states into which Colorado water flows. The availability of the real-time data has allowed the Centers to significantly improve the timeliness and accuracy of its streamflow forecasts in Colorado.

The main utility of the system as far as this office is concerned is the capability of the system to call this office when critical river levels are reached. This has been invaluable in flagging the forecasters to turn their attention to hydrologic matters. We view this as a quantum jump ahead in helping us in warning the public in the event of flooding. It would be very difficult to the National Weather Service to go back to the pre-satellite days for monitoring Colorado's streamflow conditions."

Larry Tunnell, Hydrologist
National Weather Service Forecast Office
Denver, Colorado

PROJECT MANAGER'S REPORT

The Colorado satellite-linked monitoring system, providing real-time water resources data on a continuous basis from key gaging stations across the state of Colorado, remains an integral tool in the hands of the State Engineer, Division Engineers, and Water Commissioners in its primary utility, water rights administration. The system represents an important technological advance in the state's ability to monitor and evaluate current hydrologic conditions in order to effectively carry out the statutory responsibilities of water rights administration.

The following goals and objectives set for FY 87-88 were achieved to a satisfactory degree:

- Assimilate the system into a broader range of the user community.
- Increase valid data capture to 98%.
- Evaluate quality assurance criteria for real-time data collection.
- Increase cooperation with other operators of satellite-linked data collection hardware in Colorado.
- Modify the Hydromet software to facilitate data editing and the development of the final hydrologic record.
- Control operations and maintenance costs.

The following goals and objectives set for FY 87-88 were not achieved to satisfaction:

- Obtain increased General Fund support.
A budget proposal submitted to the Joint Budget Committee requesting that the General Fund appropriation for FY 88-89 be increased from \$89,539 to \$155,525 was denied.
- Assimilate the monitoring system operationally into other Colorado state agencies.
The Division of Wildlife (DOW) did agree to provide \$2,500 to help fund WATERTALK. The DOW also made arrangements to install and operate satellite-linked data collection at the Tabor Transmountain Diversion. Efforts to increase DOW activities in this area will continue. Future system utilization should include the Water Conservation Board, the Division of Parks and Outdoor Recreation, and the Department of Health.
- Increase the network by 10%.
The network was increased by 3% from 150 to 153 stations. Insufficient funds held back desired network expansion.
- Increase the system capabilities by 20%.
The addition of WATERTALK, an upgrade in the central computer operating system, and an upgrade to the receive site demodulator operating system, increased system capability by an estimated 5%. Insufficient funds did not allow for the installation of additional sensors at selected remote stations.

The goals and objectives for FY 88-89 are:

- Obtain full General Funding for FY 89-90.
- Assimilate the monitoring system operationally into other Colorado state agencies.
- Increase the network by 5%.
- Increase the system capabilities by 10%.
- Increase system access capabilities and computing hardware in the hands of key water commissioners.
- Provide technical assistance to various water resources management entities in the state to encourage the purchase, installation, and operation of satellite-linked data collection hardware.

The multitude of court approved administration plans involving water exchanges, augmentation, and changes in points-of-diversion, inject levels of complexity that typically cannot be effectively administered without the availability of real-time data. Despite the fact that the number of adjudicated water rights increased 23% from 1982-1988, the number of water commissioners actually decreased from 94 to 93. These statistics indicate that based strictly on an increase in water rights, the number of water commissioners should have increased by twenty-two. If we consider the increased workload due to the growing complexity being incorporated recently into water rights administration, it is estimated that the number of water commissioners should have increased by thirty. The monitoring system cannot be expected to replace the need for thirty additional water commissioners but can compliment a moderate increase in the number of water commissioners.

A budget proposal has been submitted to the Joint Budget Committee of the State Legislature requesting that beginning in FY 89-90 the funds to operate and maintain the monitoring system (\$253,021) be funded entirely from the General Fund. Any user fees collected would be deducted from the General Fund appropriation. Currently, these costs are funded one-third from the General Fund and two-thirds from user fees. The cost benefits realized by the operation of the system are an estimated \$1.5 million annually. This is a ratio of nearly 6 to 1 over operating costs. Aside from cost-benefits, we need to evaluate potential cost-avoidance. If the system can potentially eliminate the need for ten additional water commissioners, savings may be an estimated \$350,000 to \$400,000 annually. The step to full General Funding is critical to the continued operation and development of the system and in making the system accessible to all Colorado water users. This office contends that the system operates for the benefit of all Colorado water users and, as such, should be funded completely from the General Fund.

An additional FTE should be seriously considered and possibly incorporated into the FY 89-90 budget. The position, System Maintenance Manager, would be responsible for both coordinating and carrying out the sustained operation and maintenance of the remote data collection hardware. As the system becomes more integrated into real-time water rights administration, there develops a greater need to maintain the operation of the monitoring network on a continuous and consistent basis. This requires a full-time position.

Expenditures for the operation of the monitoring system for FY 87-88 amounted to \$184,999. The projected budget was \$228,341. Cost reductions of \$43,343 were primarily the result of balancing expenditures to meet available funds. Total funding available was \$187,732. User fees collected were \$93,363 in FY 87-88, down from \$94,800 collected in FY 86-87. A fund of \$23,558, accumulated since 1985, was carried over for emergency expenditures. The FY 88-89 operating budget is projected to be \$248,649.

Excessive failures experienced with the remote data collection hardware continues to be an area of concern. Failures fall into two categories; unit failures requiring manufacturer repair and unit failures that could be repaired or corrected in the field. In FY 87-88, twenty-one (21) Data Collection Platforms (DCP's) were returned to the manufacturer for repair. This represents 12% of the DCP's operated by the state. The majority of the failures involved the voltage control oscillator, frequency oscillator, or an analog-to-digital chip. Nearly twice as many units failed but were made operable in the field. These intermittent failures were generally related to scrambling of operating software due to lightning strikes or other forms of static electricity, deficiency in the on-site power supply, moisture in the antenna/antenna cable, or vandalism. The cost of these failures is conservatively estimated to be between \$30,000 to \$40,000. This includes repair costs, travel costs, staff time to visit these stations and repair or exchange malfunctioning hardware, and the cost to edit invalid or lost data.

Non-state entities continue to increase their involvement in operating satellite-linked data collection stations in Colorado. These include the Northern Colorado Water Conservancy District, City of Aurora, City of Colorado Springs, Bureau of Reclamation, and the National Weather Service. The number of DCP's operated by these entities and monitored by the state's receive site totals over 130 stations.

The National Oceanic and Atmospheric Administration - National Environmental Satellite Data Information Service (NOAA-NESDIS) continues to hold quarterly meetings for users of the Geostationary Operational Environmental Satellite (GOES). Two of these meetings were attended by the system Project Manager during this last year.

A consortium of federal agencies, the Satellite Telemetry Interagency Working Group (STIWG), continues to promote the advancement of GOES Data Collection System (DCS) technology and ensure its continuation for environmental data collection. This is important for two reasons. First, the GOES DCS is being redesigned with implementation to occur in 1990. Second, GOES DCS has secondary priority relative to the operation of the GOES spacecraft. Weather imaging has the highest priority, resulting in frequent repositioning of the spacecraft for optimization of imaging at the cost of effective DCS.

GOES-WEST (GOES-6) underwent a final stabilization maneuver in May, 1988. The inclination (measure of orbital stability) will deteriorate at a rate of 1° per year. An inclination in excess of 1.9° results in signal loss. By mid-1990, a loss of two to three transmissions will occur. The new GOES series prototype, scheduled for launch in July 1990, may have narrower band widths to accommodate additional channels and increased transmission rates to handle increased data volume. Minor modifications to existing DCP's

may be required at that time. NESDIS is considering modifying the DCS specifications for GOES-NEXT, such that transponder signal strength would be decreased by 60%, effectively making the state's receive site obsolete. Efforts by NESDIS to establish a Standard Hydrological Exchange Format (SHEF) were completed. Sutron has implemented SHEF into the DCP software as an option. NESDIS advised that SHEF format will not be obligatory. NESDIS announced plans for an improved DCS ground system to be operational by 1990. System capacity will be increased to 100,000 DCP's and 5,000 users. Data transfers, aside from privately operated GOES receive sites, will be accomplished through the NOAA-PORT system utilizing the DOMSAT communications system and low-cost Direct Readout Terminals (DROTS). A DOMSAT downlink is planned for operation in Boulder, Colorado. This office remains concerned with possible future policy change by NESDIS that may require user fees to be paid to NESDIS for GOES DCS usage. The use of GOES DCS has been free of charge to the state.

A major thrust in FY 88-89 will be toward the enhancement of the monitoring system capabilities. The addition of other sensor types, including water quality, precipitation, air temperature, water temperature, and soil moisture can significantly increase the utility of the system. The Colorado Water Resources and Power Development Authority is providing \$68,048 for the purchase of various sensors for system add-on. Sensors include precipitation gages, evaporation gages, air temperature probes, pressure transducers to monitor reservoir capacity and inflow/outflow conditions for dam safety purposes, a snowpillow, a snow temperature probe, a radiometer, and water quality monitors. The system data base is now more accessible to the average individual interested in streamflow conditions through the operation of a unit (WATERTALK) that provides automatically updated computer-generated voice-synthesized messages by phone.

The state of Colorado is in the process of developing a Geographic Information System (GIS). Data acquired by the satellite-linked monitoring system would be placed in a common data base with other types of geographic-based data. The GIS would allow for the extraction of multi-characteristic information onto a common map base.

A General Fund budget proposal in HB-1021 included funds for ten GOES-linked stations in the Colorado River basin (Division 5) to enable automated water resources accounting taken over from the Bureau of Reclamation. However, funding for this particular item was denied.

The Office of the State Engineer investigated with no success the possibility of obtaining NASA research grants toward the development of operational remote sensing systems. A review of grant solicitation proposals released by the Office of Space Science and Applications revealed that only imaging types of systems were included.

The NOAA Environmental Research Laboratory, Boulder, Colorado, is evaluating flood forecasting capabilities utilizing real-time data. Access was provided to the satellite-linked monitoring system data base. The Program for Regional Observing and Forecasting (PROFS) is headed up by Dr. Lynn Johnson, University of Colorado (Denver).

John Kaliszewski, Project Manager, presented a professional paper on the Colorado Satellite-Linked Water Resources Monitoring System to the General Assembly of the International Association of the Hydrological Sciences of the International Union of Geodesy and Geophysics, International Committee on Remote Sensing and Data Transmissions for Hydrology, in Vancouver, British Columbia, Canada, on August 20, 1987.

The Office of the State Engineer presented an "Award of Appreciation" to Mr. C.L. (Tommy) Thomson, Manager of the Southeastern Colorado Water Conservancy District. Mr. Thomson has been a strong and effective advocate of real-time monitoring of the state's water resources since 1979 when the USGS-WRD chose the Arkansas River basin of Colorado as one of three test beds in the United States to evaluate the utility of satellite-linked water resources monitoring systems. He worked closely with the private contractors chosen by the USGS-WRD, the Communications Satellite Corporation (COMSAT) and its subsidiary, Environmental Research and Technology, Inc. (ERT) in developing the network configuration and making the system's data base accessible to the Division 2 Engineer. In 1983, he assisted State Senator Harold McCormick in passing legislation developing the statewide monitoring system. The award emphasizes the end benefit of the system, that is, water saved for beneficial use in Colorado.

COLORADO SATELLITE-LINKED WATER RESOURCES MONITORING SYSTEM

PROGRAM MANAGEMENT AND SUPPORT STAFF

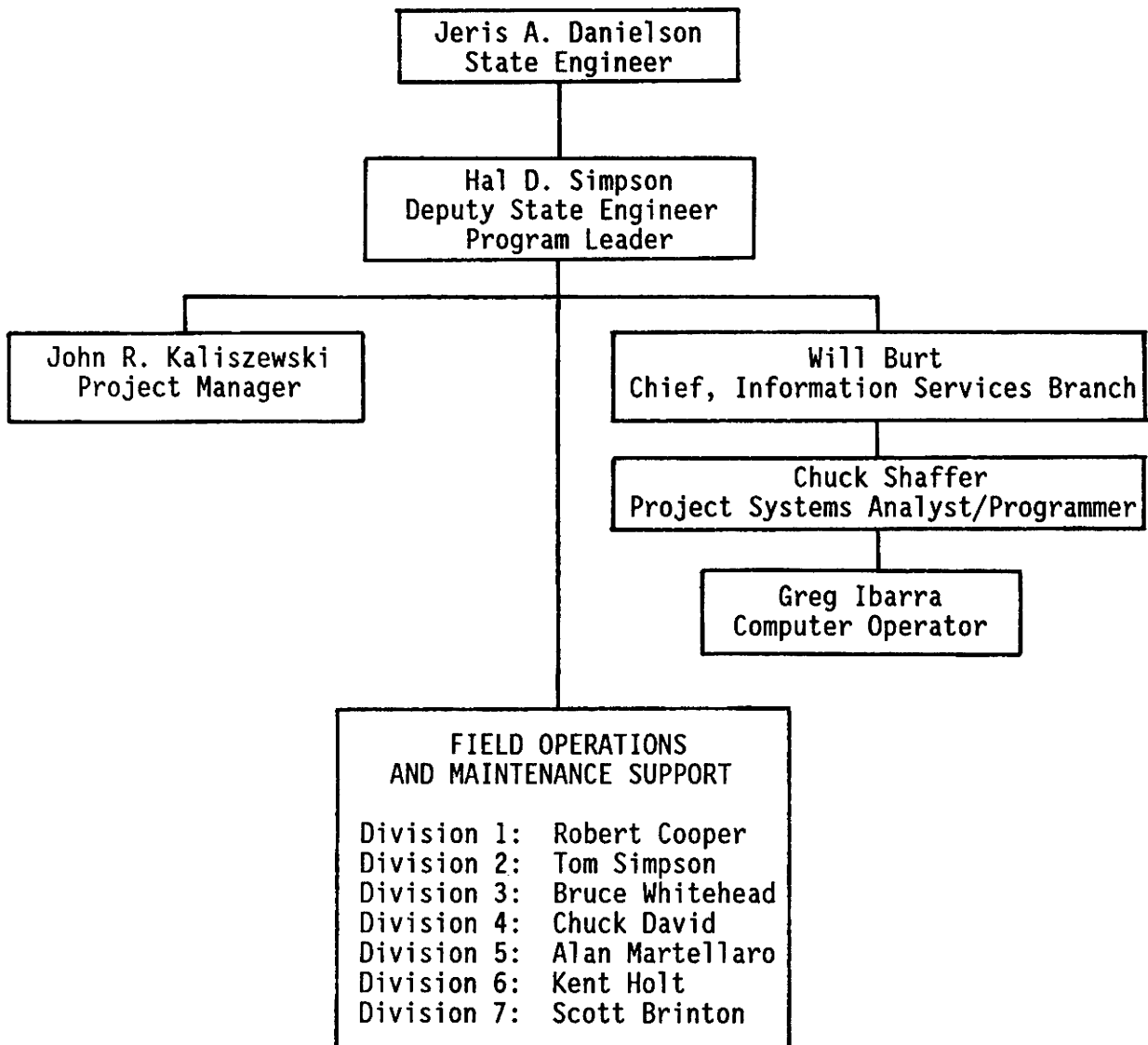

I. PROGRAM DESCRIPTION

The monitoring system represents state-of-the-art technology in real-time data collection. Although the system utilizes space age technology, it is relatively simple. Conventional data collection hardware and data processing techniques have been incorporated into the system configuration.

A. System Configuration

The system is comprised of seven basic components:

1. Gaging stations
2. Remote data collection hardware
3. Transmission receive hardware
4. Central computer
5. Applications software
6. Computer terminals for data base access
7. Satellite communications link

The remote data collection hardware is generally installed at pre-existing stream, diversion, and reservoir gaging stations. The hardware interfaces with on-site sensors. The sensor may be either a float operating in a stilling well hydraulically connected to the stream or reservoir, a manometer or other type of pressure transducer, or a direct discharge meter.

The remote site data collection hardware installed in these gaging stations includes a Data Collection Platform (DCP), an incremental analog-to-digital shaft encoder, an environmentally secure NEMA enclosure, a Yagi antenna, a 12-volt battery, a solar panel, and complimentary cables. The DCP is comprised of a sensor interface module, a microprocessor, and a UHF transmitter. The sensor interface module is capable of handling up to 16 sensors. The microprocessor provides for programmable input of data measurement and transmission scheduling, data manipulation, and data storage. The DCP is programmable by utilizing a portable terminal via an RS-232 port. The DCP measures approximately 10"x8"x4". The shaft encoder converts incremental stage values from analog to digital in hundredth of a foot intervals. The shaft encoder communicates directly with the DCP. The shaft encoders were modified with digital displays/data resets. This provides for easy sensor calibration and data display for station operators. The unit measures approximately 8"x6"x6". The NEMA enclosure houses the DCP and the battery. The unit measures approximately 24"x20"x10".

The transmission receive hardware basically consists of a 5-meter parabolic dish, downconverter, receiver, amplifier, multiplexor, and eight frequency agile programmable demodulators. This Direct Readout Ground Station is located at the Centennial Building, the Office of the State Engineer.

The central computer is comprised of a DEC VAX 11/750 computer with two 456 MByte hard disks, two 9-track tape drives (100 ips streamer mode 25 ips),

four multifunction communications boards with eight serial ports each, and 32 modems. The VAX utilizes the VMS 4.6 operating system. The system is designed to handle in excess of 350 DCP's. The central computer is located in the Centennial Building at the Office of the State Engineer.

The software, HYDROMET, was developed by the system contractor, Sutron Corporation. It is comprised of real-time data processing and archiving programs, alert/warning programs, reports and graphics output programs, and system performance monitoring programs. The software is written in Fortran.

Three ISC 2427 color CRT terminals, a Sanyo MBC-775 color CRT terminal, a Tektronix 4105A color CRT terminal, an LA 120 console printer, a 600 LPM printer, and an ISC X-Y color plotter are located in the Division of Water Resources' Denver office. Each of the seven Division offices has been provided with a Wang PC-XC3 computer having 256 KBytes of CPU. A memory expansion board increases the memory by 512 KBytes. Each unit has a software communications and productivity package, color display CRT terminal, printer, and modem. Thirty-two EPSON HX-20 portable remote terminals have been distributed to field staff and water commissioners through the Division offices. These terminals are capable of programming the DCP's via an RS-232 port and, being equipped with acoustic couplers, can provide for system access via phone communications. The DWR has tied into the state of Colorado microwave telecommunications system. A line has been provided to each Division office to provide for unlimited access to the system's central computer.

Figure 1 illustrates the system configuration.

Figure 2 illustrates the configuration of the Direct Readout Ground Station.

Figure 3 illustrates the central computer hardware configuration.

Figure 4 illustrates the data management software configuration.

The communications link for data transmissions is the Geostationary Operational Environmental Satellite (GOES). GOES is a series of federal communications satellites operated by the National Oceanic and Atmospheric Administration, National Environmental Satellite, Data, and Information Service (NOAA-NESDIS). The GOES satellites are in an equatorial, geostationary orbit at a point 22,500 miles in space. This type of orbit allows for a continuous line-of-sight to be maintained with both remote transmitters and the Direct Readout Ground Station. NOAA-NESDIS has provided the Colorado State Engineer's Office with 223 transmission slots allowing for 223 DCP's to transmit self-timed transmissions at separate 4-hour intervals, on channel 062. NOAA-NESDIS provided the use of a random reporting channel (118) for transmitting emergency messages. Currently, no fees for the use of the GOES Data Collection System (DCS) are charged to the State.

NOAA-NESDIS launched its last available GOES spacecraft (GOES-7) on February 26, 1987. It was located in the GOES-EAST position at 75°W equatorial. GOES-CENTRAL (GOES-6) was relocated to the WEST position at 136°W equatorial. The new GOES series prototype, scheduled for operation in 1990, may have narrower band widths to accommodate additional channels, and increased transmission rates to handle increased data volume. Minor modifications to existing DCP's may be required at that time. NESDIS established a Standard Hydrological Exchange Format (SHEF). Sutron implemented SHEF into the DCP software. NESDIS upgraded the current DCS ground system capacity by

nearly 20%. This was necessary as the system was approaching saturation. The saturation level was increased to 7,196 active DCP's. At the end of FY 87-88, there were 7,590 transmission assignments with 5,733 scheduled for transmission with 4,560 active. The difference in number between scheduled and active DCP's is due to seasonally operated DCP's. NESDIS announced plans for an improved DCS ground system to be operational by 1989. System capacity would be improved to 100,000 DCP's. Data transfers, aside from privately operated GOES receive sites, will be accomplished through the NOAA-PORT system utilizing the DOMSAT communications system and low-cost Direct Readout Terminals (DROTS).

B. System Operations

Data measurements are taken at the remote stations at 15-minute intervals. These data are stored and transmitted at 4-hour intervals in the standard transmission mode. The Division of Water Resources is authorized by NOAA-NESDIS and the Federal Communications Commission to transmit on GOES-WEST, channel 062, 401.7925 MHz, with a bandwidth of 1.5 KHz. Random reporting (emergency transmissions) parameters are programmed directly into the DCP, including an alert level, warning level, data rate-of-change criteria, and the desired emergency transmission interval. When these user defined thresholds are met or surpassed, the random reporting mode activates. Random transmissions, down to 2-minute intervals, are made to update the user of significant hydrologic conditions. The computer can then signal interested users. This can be accomplished by sending a message to a remote terminal, setting off an alarm at a remote terminal, or by calling a phone and giving a voice synthesized message to the answerer.

The system operates on a continuous basis and can be accessed by computer terminal via any phone line. The VAX 11/750 is equipped with 16 modems, enabling the handling of 16 users simultaneously. The Division of Water Resources reached an agreement with the Northern Colorado Water Conservancy District (Loveland) to utilize their downlink as a backup. Each downlink is programmed to receive and process the other's data transmissions. The real-time data is stored on-line for a minimum of five days. After five days, the data are dumped unless requested to be stored longer. In the case of a failure in either the Direct Readout Ground Station or the central computer, the data are not lost, but are available on the backup system. A modem-linked computer port allows direct access by the DWR to the data. As the two systems are identical, there are no problems with data format. The data are transferred by computer-to-computer dump.

GOES-WEST (GOES-6) underwent a final stabilization maneuver in May, 1988. The inclination (measure of orbital stability) will deteriorate at a rate of 1° per year. An inclination in excess of 1.9° results in signal loss. By mid-1990, a loss of two to three transmission periods daily can be expected. Launch of GOES-NEXT is scheduled for July, 1990.

DCS operation has secondary priority according to NOAA-NESDIS operating guidelines for GOES. The GOES weather imaging has the number one priority. As a consequence, the spacecraft are frequently moved to facilitate the monitoring of major weather events, e.g. hurricanes.

The GOES spacecraft undergo an eclipse period each spring and fall, where the on-board solar panels are not able to function. For a period up to two hours per day, NOAA-NESDIS deactivates the DCS due to insufficient power. The periods run February 26 to April 12 and August 31 to October 15, occurring between 2330-0130 MST. There is minimal impact on DWR DCP transmissions as less than 20% of the DCP's are scheduled to transmit in the self-timed mode during this period. To compensate, redundant data sets (current 4 hours and previous 4 hours of data) are transmitted at each self-timed transmission.

NOAA-NESDIS runs tests on all DCS channels to check the integrity of the system. Test address 15C94F4E is utilized. This transmits over regularly scheduled transmissions and causes loss of such transmissions. It is not a significant problem as it affects less than 1% of the transmissions on a given day.

Data transmissions are processed on a real-time basis. Raw data are converted into engineering units and time stamped. Discharge and contents values are computed from stage data utilizing stage-discharge and stage-contents table conversions. Shifts are automatically applied to account for changes in the stream channel characteristics affecting stage-discharge relationships as identified from actual on-site measurements. Other computations are made as necessary including stage-discharge conversions utilizing Parshall flume equations, incremental precipitation, and temperature. At the end of each 24-hour period, mean daily values are computed and archived in a separate data base file.

Maintaining data base integrity is a primary operations goal. Real-time data are of no value unless the data are accurate. Considerable effort is maintained to ensure that the remote hardware/sensor interface remains in calibration. This effort becomes compounded by the fact that nearly 65% of the stations in the state's monitoring network are operated by other entities that generally are not utilizing the data to make real-time decisions. Stations are typically visited by a hydrographer on a 2 to 4 week interval. On-site measurements are made along with any necessary calibrations. Normal data ranges for each station are entered into the central computer. If data values fall outside of the expected range, they are flagged accordingly. Flagged values are not utilized in computing mean daily values. Each day the computer reports the number of "data quality" flags for each station.

Data editing may be done to either 15-minute resolution data or the mean daily values. Editing is done on a separate working file duplicated from the original data base. In this fashion, the integrity of the real-time data is maintained. Data editing privileges, along with the ability to input data processing/data conversion commands, are restricted to authorized users. User name/password combinations carry limited privileges as determined by the system's data base manager.

At the request of the DWR, additional transmission slots were provided by NESDIS on channel 062W. The City of Colorado Springs was reassigned to channel 034W releasing 19 slots, the Northern Colorado Water Conservancy District was reassigned to channel 034W releasing 18 slots, and the City of Aurora was reassigned to channel 034W releasing 15 slots.

Seven transmission slots were set aside for test purposes:

<u>Address</u>	<u>Reporting Time (GMT)</u>	<u>Division</u>
514AD174	0246	1
514AB492	0244	2
514A718C	0240	3
514A21F0	0235	4
514A8108	0241	5
514AE4EE	0247	6
514A927E	0242	7

A number of gaging stations not incorporated into the GOES-linked monitoring network are having their respective hydrologic data entered manually into the central data base. This allows for the data to be further processed and edited for the final record utilizing the records development software. The data can be easily retrieved utilizing the Hydromet reports and graphics output programs.

The Division of Water Resources is responsible for system maintenance. Field personnel from each Division received training from Sutron technicians in the operations and maintenance of the system hardware. Two staff engineers received a week of special training at Sutron's facilities in Herndon, Virginia. Training was directed at system diagnostics, hardware calibration, and basic repairs. Each Division is supplied with a minimum of two sets of replacement hardware. If a component malfunctions and cannot be repaired in the field, that component is replaced and returned to the manufacturer for repair.

Computer generated system diagnostics reports assist in monitoring the operating qualities of the remote data collection hardware. The report tabulates the operations characteristics for each station for the previous day. The report lists the number of received, scheduled, and missed transmissions, any message length errors, transmission time errors, errors in transmission quality including power (EIRP) and frequency, any deficiency in remote power supplies, and the number of missing values and parity errors for each station. Frequently, hardware operating problems can be detected before reaching a critical (non-operative) stage.

A program is being developed that will provide for input of information relative to stations operations status. This will provide the user with information on such things as current operating conditions, data validity, and the next scheduled station maintenance.

Excessive failures experienced with the remote data collection hardware continue to be an area of concern. Failures fall into two categories; unit failures requiring manufacturer repair and unit failures that could be repaired or corrected in the field. In FY 87-88, 21 DCP's were returned to the manufacturer for repair. This represents 12% of the DCP's operated by the state. The majority of these involved the voltage control oscillator, frequency oscillator, or analog-to-digital chip. Nearly twice as many units failed but were made operable in the field. These intermittent failures were generally related to scrambling of operating software due to lightning strikes or other forms of static electricity, deficiency in the on-site power supply,

moisture in the antenna/antenna cable, or vandalism. It is hoped that the majority of component failures have surfaced and been repaired. Steps are being taken to alleviate the intermittent failures. Advanced grounding techniques are being evaluated to curtail problems associated with scrambling of operating software due to power surges. A case study on this problem showed that in a six-week period in the Arkansas River basin (Division 2), a total of twelve DCP's and shaft encoders developed the effects of scrambled operating programming requiring a station visit and reprogramming. The problem was apparently exasperated by numerous electrical storms occurring in the basin during this period.

The cost of these failures is conservatively estimated to be between \$30,000 to \$40,000. This includes repair costs, travel costs, and staff time to visit these stations and repair or exchange malfunctioning hardware, and the cost to edit invalid or lost data.

Failures in the Direct Readout Ground Station occurred five times during FY 87-88. These were generally related to power surges or power failures. Except for one occurrence which happened on a weekend, the failures had insignificant impact. The clock on the VAX 11/750 central computer continues to lose 20 to 25 seconds per week. This does not raise a critical problem but does require that the clock be reset every two to three days. The exact time is found by contacting the National Bureau of Standards facility located in Boulder, Colorado. Clocks in the DCP's are calibrated in the same fashion. However, those clocks are more stable, losing no more than 10 to 20 seconds annually.

Poor quality phone lines in several areas of the state are responsible for problems in accessing the system's central computer remotely. Simple log-on becomes quite difficult. Future plans by Mountain Bell to improve these lines will resolve the problem.

Communications with NOAA-NESDIS, other GOES DCS users, and the Colorado user community is essential. NOAA-NESDIS coordinates the activities of two national GOES DCS user groups, the Technical Working Group and the Direct Readout Ground Station Working Group. Meetings are held quarterly to discuss GOES DCS operations, future system improvements, system utility, and to facilitate communications between users. These meetings have proven to be beneficial. The Project Manager attends two of the four meetings annually. Within the state of Colorado, a consortium of governmental agencies (federal, state, and municipal) have formed a committee to coordinate activities within the state related to hydrology-meteorology. The Hydromet Committee has been instrumental in promoting real-time data collection in Colorado.

The monitoring system continues to operate with only two full-time employees, the Project Manager and the Systems Analyst/Programmer. The Project Manager's responsibilities include the coordination of daily operations, network development, system enhancement, maintaining communications with the user community, interagency/intra-agency coordination, user fee development, budget management, and the coordination of the development of system applications and utilization. The Systems Analyst/Programmer's responsibilities include the operation of the receive site and central computer, data base management, control and management of system access by the user community, software modification and development, and ADP training. A third

position, Systems Maintenance Manager, remains unfilled due to budgetary constraints. However, with future additions to the network, sensor add-ons, and increasing primary duties of field staff, this position will become necessary. Essential support is provided from other staff. Program direction is provided by the State Engineer and Deputy State Engineer. The Chief of the Division's Branch of Information Services provides technical support and provides the part-time services of a computer operator. Systems operations and maintenance support is provided by each of the seven Division offices. Each Division has assigned a hydrographer in charge of maintenance of the remote data collection hardware in his Division.

C. System Software

The HYDROMET software package is comprised of a series of programs that provide for transmission receive, raw data processing, data conversions, data archiving, data retrieval in various reports and graphics formats, and system diagnostics. The following is a description of the basic applications programs utilized by the user:

1. DAYFILES maintains and provides access to the real-time data being collected for a given station. This program performs raw data processing, data conversions, shift applications, and archiving of the real-time data. Figure 5 is an example of a DAYFILES report.
2. ARCHIVES computes and stores mean daily values for a given data type for a given station. Figure 6 is an example of an ARCHIVES report.
3. ANNUAL provides a yearly summary of mean daily values for a given data type for a given station. It also summarizes by month the total, mean, minimum, maximum, and any special conversions, i.e. mean daily discharge to acre-feet. The format matches that established by the U. S. Geological Survey-Water Resources Division and accepted by the Colorado Division of Water Resources for publication purposes. Figure 7 is an example of an ANNUAL report.
4. PLOT provides for the development of graphical displays of data values plotted against time. In the case of discharge data, this produces a hydrograph. Figure 8 is an example of a plot of DAYFILES data. FIGURE 9 is an example of a plot of ARCHIVES data. Figure 10 is an example of a plot of ANNUAL data.
5. SCHEMATICS provides for a graphical display of the relative locations of monitoring stations along with the most recent data for each station. Figure 11 represents the lower reaches of the Division 3 monitoring network.
6. DIAGNOSTICS provides a detailed daily summary of the operating characteristics for a network of stations. This includes such things as missed transmissions, parity errors, missing data values, remote battery power, transmission power, and data base quality flags.

Additional programs have been developed internally to supplement the Hydromet software. SMSEQPT provides for a computerized inventory and tracking system for the remote data collection hardware, primarily 166 DCP's and 166 shaft encoders with a replacement cost of \$650,000.00. RECORD was developed to facilitate the development of the hydrologic records. It modifies the Hydromet records development programs to better meet the needs and requirements of the Division of Water Resources. Data editing can be performed on either the 15-minute resolution data or the mean daily values. Editing is done on a separate working file duplicated from the original data base. In this fashion, the integrity of the real-time data is maintained. This is necessary since administrative decisions are based on the evaluation of real-time data. LOG was developed to monitor transmission activity on a specified demodulator. This includes scheduled and unscheduled transmissions making it possible to identify unauthorized transmissions that could cause interference problems.

D. System Capabilities

The ability to collect data remotely on a real-time basis is the most fundamental capability of the system. The latest data values are never more than four hours old. Random (emergency) transmissions update the data base at intervals down to two minutes if user defined thresholds at the remote site are surpassed. The remote data collection hardware is easily installed and can be operated in remote locations utilizing portable power packs and solar panels. The hardware can be operated in a wide environmental range from -40°C to +55°C. The DCP's are user programmable in the field. The units are capable of interfacing with up to 16 sensors simultaneously in either analog or digital mode. Very few locations in Colorado do not have a line-of-sight with either GOES-CENTRAL or GOES-WEST. As the GOES spacecraft are in a geostationary orbit, continuous communications can be maintained. The Direct Readout Ground Station can operate in an urban environment with negligible radio frequency interference. The receive site is equipped with eight demodulators allowing the monitoring of eight GOES channels simultaneously. A Sutron developed program was installed in FY 87-88 that allows for programmable operation of the demodulators. Operator input directs the demodulators to switch channels by time. All transmissions through GOES are in the public domain. The state's receive site is thus capable of monitoring all transmissions of interest through either GOES-CENTRAL or GOES-WEST. The system is capable of handling a minimum of 350 DCP's. Data storage capacity is 912 MBytes. Up to 16 users can access the system simultaneously. The system evaluates incoming transmissions and prepare a detailed summary of pertinent operating characteristics.

The Office of the State Engineer operates a computer accessory unit, WATERTALK, that allows data to be output to the user by phone using computer-generated voice-synthesis. The user can dial the WATERTALK unit, located in Denver, and receive up-to-date flow conditions at key gaging stations across the state by input of commands utilizing the keypad of a touch-tone phone. Flow information is automatically up-dated by the central computer in communicating with WATERTALK. Four phone lines are dedicated for WATERTALK user access such that four users can access the unit simultaneously.

Data transmissions are processed in an automated fashion on a real-time basis. Data conversions including analog-to-digital, stage-to-discharge, and mean daily values computations are performed in an automated fashion based on user input. Data are automatically screened and appropriately flagged if they fall outside of a user defined normal range, thus providing a basis for data quality assurance. Data editing routines, with access controlled by user name/password, allow for data base modification in both the real-time data and the archival data base. Data for stations not in the monitoring network may be entered manually, from computer-to-computer transfer, or by computer tape.

The data can be retrieved and output in various reports and graphics formats. The most fundamental output format for the evaluation of flow data is the hydrograph. Data from up to four stations or from four periods of record for a single station can be plotted on a single hydrograph.

The system is able of providing flood warnings. If river conditions surpass user identified high water levels, the system automatically sends out warning messages to designated personnel by either computer-to-computer communications or by delivering a voice-synthesized message over the phone.

E. Future System Developments

The satellite-linked monitoring system can be both expanded and enhanced to increase its capabilities and effectiveness. The expansion of the state's monitoring network and the enhancement of the system by the addition of other sensor types will be limited by the availability of funds. The cost to purchase and install GOES-linked data collection hardware at an existing shelter is approximately \$5,500 per station. Refer to Appendix A. Current funding levels do not provide for capital expenditure beyond hardware replacement costs. There is a large variety of sensor types available over a wide cost range. Sensors are available that can interface with the Sutron DCP and provide valuable data on a real-time basis. These include precipitation, air temperature, water temperature, soil moisture, snow depth, solar radiation, pH, dissolved oxygen, conductivity, wind direction and speed, humidity, and soil temperature. Costs for specific sensors range from \$300 to \$4,500. Refer to Appendix B. The need for additional data must be coupled with funds from the state of Colorado and from various user groups to cover the costs.

The Office of the State Engineer, Division of Water Resources, can justify the need for an additional 25 to 30 satellite-linked monitoring stations to assist in water rights administration. This office is also interested in real-time data that can assist in runoff forecasting and in dam safety monitoring. Other state agencies including the Division of Wildlife and the Department of Health identified the need for an additional 20 to 25 stations. The Division of Wildlife is interested in monitoring minimum streamflows and water quality relative to fisheries management. The Department of Health is interested in monitoring basic water quality parameters. The Office of the State Engineer has made the receive site and central computer facilities available to any state agency desiring to get involved in GOES-linked data collection. Technical expertise will also be provided on a cooperative basis.

Numerous non-state water resources management entities are planning on installing and operating additional satellite-linked stations statewide. These include the National Weather Service, Bureau of Reclamation, Northern Colorado Water Conservancy District, City of Colorado Springs, and the City of Aurora. The National Weather Service (NWS) has installed sensors measuring air temperature and precipitation along with stage at 38 stations in the Colorado River basin in Colorado. Through a cooperative agreement, the NWS installed precipitation and air temperature sensors at two state operated stations, Colorado River near Dotsero and the Blue River below Green Mountain Reservoir. The Northern Colorado Water Conservancy District is planning on installing additional GOES-linked meteorological stations for use in runoff forecasting and irrigation planning. The Bureau of Reclamation and the City of Colorado Springs are planning on the installation and operation of real-time monitoring stations for reservoir management and dam safety. The City of Aurora will be increasing its network of stations in South Park for water resources accounting. The stations that are of interest to the user community will be monitored by the state's system.

The input of historic flow data into the system's data base for key gaging stations in Colorado is expected to be completed by early 1989. This will allow for comparisons of recent data with data covering in some cases 100 years of record. Current flow conditions can be compared with normal, wet, and dry periods. Examples of historic flow records available are:

<u>Station</u>	<u>Initial Date of Record</u>
Arkansas River at La Junta	1889
Arkansas River at Pueblo	1885
Big Thompson River at Mouth of Canyon near Drake	1887
Cache La Poudre at Mouth of Canyon near Fort Collins	1881
South Platte River at Denver	1889
Dolores River at Dolores	1895
Gunnison River near Grand Junction	1894
Rio Grande near Del Norte	1889

It has become evident that there are situations where short-term real-time data collection is necessary. This could include stations for flood warning, dam safety, or for specific water rights administration such as water exchanges. An example of one of these uses took place in May, 1987, when the Cucharas Reservoir (Division 2, Arkansas River basin) showed signs of possible dam failure. The reservoir was at near capacity with 51,000 acre-feet of water. A monitoring station was installed the next day at the reservoir utilizing a pressure transducer to monitor stage elevation. Another station was installed upstream on the Cucharas River to monitor inflow. Both stations remained operational until August 1, 1987. Four sets of remote data collection hardware, portable shelters, and sensors are being pre-packaged to assist in meeting future needs.

The ability to extract information from the enormous amounts of real-time data being collected can be enhanced through the development of more sophisticated software. Currently, several Division offices are developing various water resources accounting programs. Programs in the area of short-term runoff forecasting and automated river call determination are of special interest. Program development will come slow over the next two years but will

gradually increase momentum as the monitoring system becomes more integrated into daily water rights administration.

The Colorado Water Resources and Power Development Authority authorized expenditures of \$68,048 for the purchase of sensor hardware to enhance the capabilities of the monitoring system. The system enhancements are solid concepts from a perspective of upgrading the system from a pure hydrological function to a broader application that has potential for major future expansion. The elements of the system enhancements include:

	<u>Cost of Hardware</u>
<u>Item #1</u> Dam safety monitoring hardware package	\$20,087
This hardware will be utilized to develop a mobile real-time dam safety monitoring package. It will consist of four monitoring stations comprised of satellite-linked data collection hardware and six water level measurement sensors. The stations would provide for monitoring of reservoir inflow, reservoir contents, reservoir outflow, reservoir seepage, and piezometers within the dam.	
<u>Item #2</u> Air temperature monitoring sensors	\$12,348
Twenty-eight stream gaging stations will be instrumented with air temperature sensors. The data will be utilized to correlate discharge when the hydrologic record is ice effected.	
<u>Item #3</u> Water quality monitoring hardware package	\$13,534
This hardware will be utilized to develop a mobile real-time water quality monitoring package. It will consist of two monitoring stations comprised of satellite-linked data collection hardware and multi-parameter water quality probes capable of monitoring conductivity, water temperature, dissolved oxygen, and pH.	
<u>Item #4</u> Precipitation monitoring sensors	\$13,555
Seven gaging stations will be instrumented with automated precipitation monitoring sensors. The sensors will be of the weighing bucket type capable of measuring both liquid (rain) and frozen (snow) precipitation.	
<u>Item #5</u> Snowpack monitoring and runoff forecasting	\$ 5,820
The package will consist of a precipitation sensor, snowpillow, air temperature sensor, snow temperature sensor, and solar radiation sensor.	

Item #6 Evaporation monitoring sensors

\$ 2,704

Two gaging stations will be instrumented with automated evaporation sensors.

F. Monitoring System Network

The real-time hydrologic data collection network operated by the state of Colorado is comprised of 153 stations. These stations were selected by the State Engineer, Division Engineers, and Water Commissioners with an emphasis on the need for real-time data for water rights administration. The following is a tabulation of the location of these stations by division/river basin:

- Division 1 / South Platte River Basin, 35 stations
- Division 2 / Arkansas River Basin, 44 stations
- Division 3 / Rio Grande Basin, 18 stations
- Division 4 / Gunnison River Basin, 11 stations
- Division 5 / Colorado River Basin, 22 stations
- Division 6 / White/Yampa River Basin, 7 stations
- Division 7 / Dolores/San Juan River Basins, 15 stations

A detailed list of these stations is included in Table 1. In the network development, the primary considerations are administrative importance, utility in project management, and the interrelationship of each station to other stations in a subnetwork. The goal is to incorporate those stations that satisfied as many of these requirements as possible in order to obtain maximum benefits from real-time data collection. The most important element in network development is in establishing station interrelationships. Rather than selecting stations, it is more important to incorporate integrated subnetworks. Data collected from one station are not as useful as information extracted from a subnetwork of stations. This is critical for compact administration, project management, developing water resources accounting systems, and in developing water resources management programs. Changes in the network can be made at any time at the discretion of the State Engineer or one of the Division Engineers. Four stations were substituted for in the last 12 months as a result of an evaluation of the utility of real-time data or due to a change in specific water rights administration. The remote data collection hardware is easily removed and installed at a substitute gaging station.

Considerable cooperation was necessary in developing this network. Ninety-nine (99) of the 150 gaging stations installed with remote data collection hardware by the State of Colorado are owned and operated by non-state entities. Access and installation agreements were negotiated with the following:

<u>Entity</u>	<u>Number of Stations</u>
U. S. Geological Survey - Water Resources Division	30
U. S. Bureau of Reclamation	18
Denver Water Board	9
Northern Colorado Water Conservancy District	4
Farmers Reservoir and Irrigation Company	1
North Sterling Irrigation District	1

<u>Entity</u>	<u>Number of Stations</u>
Riverside Irrigation Company	1
U. S. Army Corps of Engineers	2
City of Colorado Springs	2
City of Pueblo	5
Highline Canal Company	1
Twin Lakes Canal Company	1
Catlin Canal Company	2
Fort Lyon Canal Company	3
Oxford Farmers Canal Company	1
Rocky Ford Highline Canal Company	1
Colorado Canal Company	1
Holbrook Canal Company	1
Upper Yampa Water Conservancy District	1
Water Supply and Storage Company	2
Lower Latham Ditch Company	1
Lamar Canal Company	1
Union Ditch Company	1
Mutual Irrigation Company	1
Terrace Irrigation Company	1
South Canal Company	1
Grand Valley Water Conservancy District	1
Grand Valley Water Users Association	1
Silt Water Conservancy District	2
MVI Diversion Company	1
La Plata and Cherry Creek Ditch Company	1

The cooperation that has been extended to the Office of the State Engineer by these entities is invaluable and demonstrates the interest by the water user community in the satellite monitoring system.

Various entities involved with water resources management and development within the state of Colorado have installed and are operating hydrological real-time data collection hardware in Colorado utilizing the GOES satellite as a communications link. As this is a federal satellite, all resource data transmitted through the satellite data collection system are in the public domain. The State Engineer's Office can schedule its Direct Readout Ground Station to receive and process these raw transmissions. As of July 1, 1986, there were 101 such stations being monitored. The State Engineer's Office is cooperating with these entities in planning network expansion to maximize utility of real-time data collection without redundancy. A list of these stations is included in Table 1.

Twenty-three satellite-linked monitoring stations operated by the state of Colorado are done so on a seasonal basis only. These stations are primarily gages at transmountain diversions and irrigation diversions where actual diversions are not made during the winter months, and at high elevation sites where ice-effects negate a valid record.

TABLE 1

SATELLITE-LINKED DATA COLLECTION NETWORK
 MONITORED BY THE STATE OF COLORADO
 DIRECT READOUT GROUND STATION

Stations Operated by the State of Colorado
 Office of the State Engineer

	<u>Data Type</u>
<u>DIVISION 1</u> (South Platte River Basin)	
1. South Platte River at Waterton	S
2. South Platte River near Kersey	S
3. South Platte River at Balzac	S
4. Boulder Creek near Eldorado Springs	S
5. South Platte River at Julesburg, Channel #4	S
6. South Platte River at Julesburg, Channel #2	S
7. South Platte River near Weldona	S
8. Big Thompson River in the Canyon	S
9. St. Vrain Creek at Lyons	S
10. St. Vrain Creek at Mouth near Platteville	S
11. Cache La Poudre at Mouth of Canyon near Fort Collins	S
12. Cache La Poudre near Greeley	S
13. Harold D. Roberts Tunnel	S
14. Moffat Water Tunnel	S
15. Alva B. Adams Tunnel	S
16. Burlington-Wellington Canal at the Headgate	S
17. North Sterling Canal at the Headgate	S
18. Riverside Canal at Reservoir Inlet Gage	S
19. Boulder Creek near Orodell	S
20. Laramie Poudre Tunnel	S
21. Grand River Ditch	S
22. Big Thompson River above Lake Estes	S
23. Olympus Tunnel	S
24. North Fork Big Thompson River at Drake	S
25. Hoosier Pass Tunnel	S
26. South Platte River at Fort Lupton	S
27. Lower Latham Ditch	S
28. Union Ditch	S
29. South Platte River below Strontia Springs	S
30. South Platte River below Chatfield Reservoir	S
31. Metro Sewage Effluent Outlet Gage	S

Data Type

DIVISION 1 (South Platte River Basin) cont.

32. Hansen Feeder Canal	S
33. Cheesman Reservoir	SE
34. South Boulder Creek below Gross Reservoir	S
35. Big Thompson River below Lake Estes	S

Division 2 (Arkansas River Basin)

1. Arkansas River at Portland	S
2. Arkansas River above Pueblo	S
3. Arkansas River near Nepesta	S
4. Arkansas River near Avondale	S
5. Arkansas River near Wellesville	S
6. Arkansas River at La Junta	S
7. Arkansas River at Las Animas	S
8. Purgatoire River near Las Animas	S
9. Fountain Creek near Pinon	S
10. Purgatoire River near Thatcher	S,WT,C
11. Lake Fork Creek above Turquoise Lake	S
12. John Martin Reservoir	SE
13. Arkansas River at Catlin Dam near Fowler	S
14. Purgatoire River at Ninemile Dam near Higbee	S
15. Charles H. Boustead Tunnel	S
16. Homestake Tunnel	S
17. Busk-Ivanhoe Tunnel	S
18. Twin Lakes Tunnel	S
19. Ewing Ditch	S
20. Kicking Bird Canal	S
21. Purgatoire River below Trinidad Reservoir	S
22. Purgatoire River at Madrid	S
23. Fort Lyon Storage Canal	S
24. Cheyenne Creek near Stateline	S
25. Pueblo Water Works Diversion	DM
26. Lake Creek below Twin Lakes	S
27. Lake Fork Creek below Sugar Loaf	S
28. Timpas Creek near Rocky Ford	S
29. Amity Canal	S
30. Lamar Canal	S
31. Crooked Arroyo near Swink	S
32. Arkansas River at Granada	S
33. Wurtz Ditch	S
34. Columbine Ditch	S
35. Pueblo Reservoir	SE
36. Larkspur Ditch	S
37. Arkansas River below John Martin Reservoir	S
38. Fort Lyon Canal at the Headgate	S
39. Catlin Canal at Gage Downstream from Catlin Dam	S
40. Oxford Farmers Ditch at Headgate	S
41. Rocky Ford Highline Canal at Headgate	S
42. Colorado Canal at Headgate	S
43. Holbrook Canal at Headgate	S
44. Horse Creek at Highway 194	S

Data Type

Division 3 (Rio Grande Basin)

1. Rio Grande near Del Norte	S
2. Rio Grande near Lobatos	S
3. Rio Grande at Thirty-Mile Bridge near Creede	S
4. Conejos River near Mogote	S
5. Conejos River near La Sauses, North Channel	S
6. Conejos River near La Sauses, South Channel	S
7. Los Pinos River near Ortiz	S
8. San Antonio River at Ortiz	S
9. Alamosa Creek above Terrace Reservoir	S
10. Conejos River below Platoro Reservoir	S
11. Closed Basin Project Outlet	S
12. Terrace Reservoir	SE
13. Rio Grande above the Mouth of Trinchera Creek	S
14. Saguache Creek near Saguache	S
15. La Jara Creek near Capulin	S
16. South Fork Rio Grande at South Fork	S
17. Rio Grande at Alamosa	S
18. Rio Grande River near Monte Vista	S

Division 4 (Gunnison River Basin)

1. Surface Creek near Cedaredge	S
2. Gunnison River below the East Portal of the Gunnison Tunnel	S
3. Surface Creek at Cedaredge	S
4. Muddy Creek above Paonia Reservoir	S
5. Muddy Creek below Paonia Reservoir	S
6. Cimarron River near Cimarron	S
7. South Canal	S
8. Uncompaghre River near Ridgway	S
9. Dallas Creek near Ridgway	S
10. Redlands Canal near Grand Junction	S
11. San Miguel River at Naturita	S

Division 5 (Colorado River Basin)

1. Blue River below Dillon	S
2. Dillon Reservoir	SE
3. Blue River below Green Mountain Reservoir	S
4. Green Mountain Reservoir	SE
5. Williams Fork below Williams Fork Reservoir	S
6. Colorado River at Hot Sulphur Springs	S
7. Eagle River below Gypsum	S
8. Fryingpan River near Ruedi	S
9. Colorado River near Dotsero	S
10. Williams Fork Reservoir	SE
11. Colorado River below Lake Granby	S
12. Lake Granby	SE
13. Willow Creek Reservoir	SE
14. Shadow Mountain Reservoir	SE

Data Type

Division 5 (Colorado River Basin) cont.

- | | |
|---|---|
| 15. Willow Creek Pump Canal | S |
| 16. Government Highline Canal | S |
| 17. Grand Valley Canal | S |
| 18. Plateau Creek near Cameo | S |
| 19. Rifle Creek below Rifle Gap Reservoir | S |
| 20. Grass Valley Canal | S |
| 21. Fryingpan River near Thomasville | S |
| 22. Willow Creek below Willow Creek Reservoir | S |

Division 6 (White/Yampa River Basin)

- | | |
|--|---|
| 1. Pot Creek near Vernal, UT | S |
| 2. Illinois River near Rand | S |
| 3. Elk River at Clark | S |
| 4. Coal Creek at Mouth near Yampa | S |
| 5. Michigan River near Gould below the Confluence of the North and South Forks | S |
| 6. Little Snake River near Slater | S |
| 7. Bear Creek near Toponas | S |

Division 7 (Dolores and San Juan River Basins)

- | | |
|--|---|
| 1. Lost Canyon Creek near Dolores | S |
| 2. Navajo River below Oso Diversion Dam | S |
| 3. Rio Blanco below Blanco Diversion Dam | S |
| 4. La Plata River at Hesperus | S |
| 5. La Plata River at Colorado-New Mexico Stateline | S |
| 6. Dolores River at Dolores | S |
| 7. Dolores Tunnel | S |
| 8. MVI II Diversion | S |
| 9. Azotea Tunnel Outlet near Chama, NM | S |
| 10. Mancos River near Mancos | S |
| 11. Dolores River below McPhee Reservoir | S |
| 12. Florida River below Lemon Reservoir | S |
| 13. Florida River above Lemon Reservoir | S |
| 14. La Plata and Cherry Creek Ditch | S |
| 15. Pine River below Vallecito Reservoir | S |

**Stations Operated by the
U. S. Army Corps of Engineers (Omaha District)**

<u>Division 1</u> (South Platte River Basin)	<u>Data Type</u>
1. Bear Creek at Kittredge	P
2. Bear Creek at Morrison	S,P
3. Bear Creek Reservoir	SE,P
4. Bear Creek at Sheridan	S,P
5. Chatfield Reservoir	SE,P
6. Cherry Creek at Parker	P,AT
7. Clear Creek at Blackhawk	P
8. Clear Creek at Derby	S,P
9. Clear Creek at Georgetown	P,AT
10. Clear Creek near Golden	S,P
11. Conifer	P
12. South Platte River below Cheesman Reservoir	S,P
13. South Platte River at Denver	S
14. North Fork South Platte River at Grant	S,P,AT
15. South Platte River above Elevenmile Reservoir	S,P,AT
16. South Platte River at Henderson	S,P
17. South Platte River at South Platte	S,P
18. Plum Creek at Larkspur	P
19. Cherry Creek Reservoir	SE,P

**Stations Operated by the
National Weather Service, Colorado River Forecast Center
(Salt Lake City)**

Division 3 (Rio Grande Basin)

1. Rio Grande Reservoir	P,AT
-------------------------	------

Division 4 (Gunnison River Basin)

1. Blue Mesa Reservoir	P,AT,SE
2. Crested Butte	P,AT
3. Gunnison River at Delta	S,P,AT
4. East River at Almont	S,P,AT
5. Gunnison River near Grand Junction	S,AT
6. Ouray	P,AT
7. Paonia	P,AT
8. San Miguel River near Placerville	S,P,AT
9. Sargents	P,AT
10. North Fork Gunnison River near Somerset	S,AT
11. Taylor River at Almont	S,AT
12. Gunnison River near Gunnison	S,P,AT
13. Dolores River near Bedrock	S,P,AT
14. Taylor Park Reservoir	P,SE
15. Uncompaghre River near Colona	S,P

Data Type

Division 5 (Colorado River Basin)

1. Breckenridge	P,AT
2. Colorado River near Cameo	S
3. Colorado River below Glenwood Springs	S,P,AT
4. Colorado River near Kremmling	S
5. Colorado River near Colorado-Utah Stateline	S,AT
6. Dillon	P,AT
7. Grand Lake	P,AT
8. Meredith	P,AT
9. Roaring Fork River near Aspen	S,P,AT
10. Roaring Fork River at Glenwood Springs	S
11. Ruedi Reservoir	SE,P,AT
12. Winter Park	P,AT
13. Eagle River at Redcliff	AT,P,S
14. Piney River near State Bridge	AT,P,S
15. Crystal River near Avalanche Creek	AT,P,S
16. Eagle River near Redcliff	AT,P,S

Division 6 (White/Yampa River Basin)

1. White River near Meeker	S,P,AT
2. Yampa River near Maybell	S,AT
3. Little Snake River near Lily	S,P
4. Little Snake River near Dixon, WY	S,P,AT

Division 7 (Dolores and San Juan River Basins)

1. Animas River at Durango	S,P,AT
2. San Juan River at Pagosa Springs	S,P,AT
3. Vallecito Reservoir	SE,P,AT

**Stations Operated by the
National Weather Service, Central Forecast Office
(Denver)**

Division 1 (South Platte River Basin)

1. Clear Creek at Lawson	S
2. Big Thompson River North Fork near Drake	S,AT

Division 6 (White/Yampa Basin)

1. North Platte River near Northgate	S
--------------------------------------	---

**Stations Operated by the
U. S. Geological Survey - Water Resources Division**

Division 1 (South Platte River Basin) Data Type

- | | |
|------------------------------------|---|
| 1. Boulder Creek at Boulder | S |
| 2. Cache La Poudre at Fort Collins | S |

Division 2 (Arkansas River Basin)

- | | |
|-------------------------------------|----|
| 1. Arkansas River near Coolidge, KS | S |
| 2. Frontier Ditch near Coolidge, KS | S |
| 3. Trinidad Reservoir | SE |
| 4. Fort Lyon Canal near Cornelia | S |
| 5. Fort Lyon Canal near Big Bend | S |

Division 6 (White/Yampa River Basin)

- | | |
|--------------------------------|--------|
| 1. Yampa River near Oak Creek | S,WT,C |
| 2. Yampa River near Deer Lodge | S,WT,C |

Division 7 (Dolores and San Juan River Basins)

- | | |
|-------------------------------------|---|
| 1. Animas River near Cedar Hill, NM | S |
| 2. San Juan River at Farmington, NM | S |

**Stations Operated by the
U. S. Bureau of Reclamation**

Division 3 (Rio Grande Basin)

- | | |
|----------------------|------|
| 1. Platoro Reservoir | SE,P |
|----------------------|------|

Division 4 (Gunnison River Basin)

- | | |
|-------------------------|----|
| 1. Silverjack Reservoir | SE |
| 2. Paonia Reservoir | SE |
| 3. Ridgway Reservoir | SE |

Division 5 (Colorado River Basin)

- | | |
|--|------------|
| 1. Lincoln Creek below Grizzly Reservoir | S,P,SR,AT |
| 2. Roaring Fork River above Lost Man Creek | S,P,SR,AT |
| 3. Mormon Control House | DM,P,SR,AT |
| 4. Chapman Control House | DM,P,SR,AT |

**Stations Operated by the
Northern Colorado Water Conservancy District**

Division 5 (Colorado River Basin)

1. Upper Fraser River above Winter Park	S
2. Lower Fraser River near Winter Park	S
3. St. Louis Creek above Fraser	S
4. Ranch Creek above Tabernash	S
5. Crooked Creek at Tabernash	S
6. Ten Mile Creek near Granby	S
7. Strawberry Creek near Granby	S
8. Vasquez Creek at Winter Park	S
9. Berthoud Pass Meteorological Station	SW, ST, SMU, SML, P, AT, SR
10. Arrow Meteorological Station	SW, ST, SMU, SML, P, AT
11. Fraser Meteorological Station	SW, ST, SMU, SML, P, AT
12. Meadow Creek Meteorological Station	SW, ST, SMU, SML, P, AT
13. Cottonwood Pass Meteorological Station	SW, ST, SMU, SML, P, AT
14. Granby Meteorological Station	SW, ST, SMU, SML, P, AT
15. Fraser River near Windy Gap	S
16. Upper Blue River	S

**Stations Operated by the
City of Aurora**

	<u>Data Type</u>
<u>Division 1</u> (South Platte River Basin)	
1. Michigan River near Jefferson	S
2. South Platte River above Spinney	S
3. Fourmile Creek near Hartsel	S
4. Middle Fork at Santa Maria	S
5. Fourmile Creek at Highcreek	S
6. Middle Fork at Prince	S
7. South Fork above Antero	S

**Stations Operated by the
City of Colorado Springs**

Division 2 (Arkansas River Basin)

1. Fountain Creek at Fountain	S
2. Fountain Creek at Pueblo	S
3. Fountain Creek at Security	S

**Station Operated by the
Santa Maria Reservoir Company**

Division 3 (Rio Grande Basin)

1. Continental Reservoir	SE
--------------------------	----

**Station Operated by the
Rio Grande Water Users Association**

Division 3 (Rio Grande Basin)

- | | |
|---------------------|---|
| 1. Rio Grande Canal | S |
|---------------------|---|

**Station Operated by the
Division of Wildlife**

Division 3 (Rio Grande Basin)

- | | |
|----------------------------------|---|
| 1. Tabor Transmountain Diversion | S |
|----------------------------------|---|

**Future Stations To Be Operated by the
Colorado-Ute Electric Association, Inc.**

Division 1 (South Platte River Basin)

- | | |
|---------------|---|
| 1. Floyd Hill | V |
| 2. Foothills | V |
| 3. Sedalia | V |

Division 4 (Gunnison River Basin)

- | | |
|-----------------------|----|
| 1. Trout Lake | SE |
| 2. Trout Lake Outflow | S |

Division 7 (Dolores and San Juan River Basins)

- | | |
|---------------------------|----|
| 1. Electra Lake Outflow | S |
| 2. Electra Lake Diversion | S |
| 3. Electra Lake | SE |

**Future Station To Be Operated by the
Aspen Consolidated Sanitation District**

Division 5 (Colorado River Basin)

- | | |
|---|---|
| 1. Roaring Fork River below Maroon Creek near Aspen | S |
|---|---|

**Stations Operated by the
Southwestern Conservation District**

Division 7 (Dolores and San Juan River Basins)

- | | |
|---|---|
| 1. Cherry Creek near Red Mesa | S |
| 2. Long Hollow Creek at the Mouth Near Red Mesa | S |

Data Type Abbreviations

S	Stage
SE	Stage Elevation (Reservoir)
DM	Discharge Meter
P	Precipitation
AT	Air Temperature
SR	Solar Radiation
SW	Snow Water
ST	Snow Temperature
SMU	Soil Moisture Upper
SML	Soil Moisture Lower
V	Voltage Metering
C	Conductivity
WT	Water Temperature

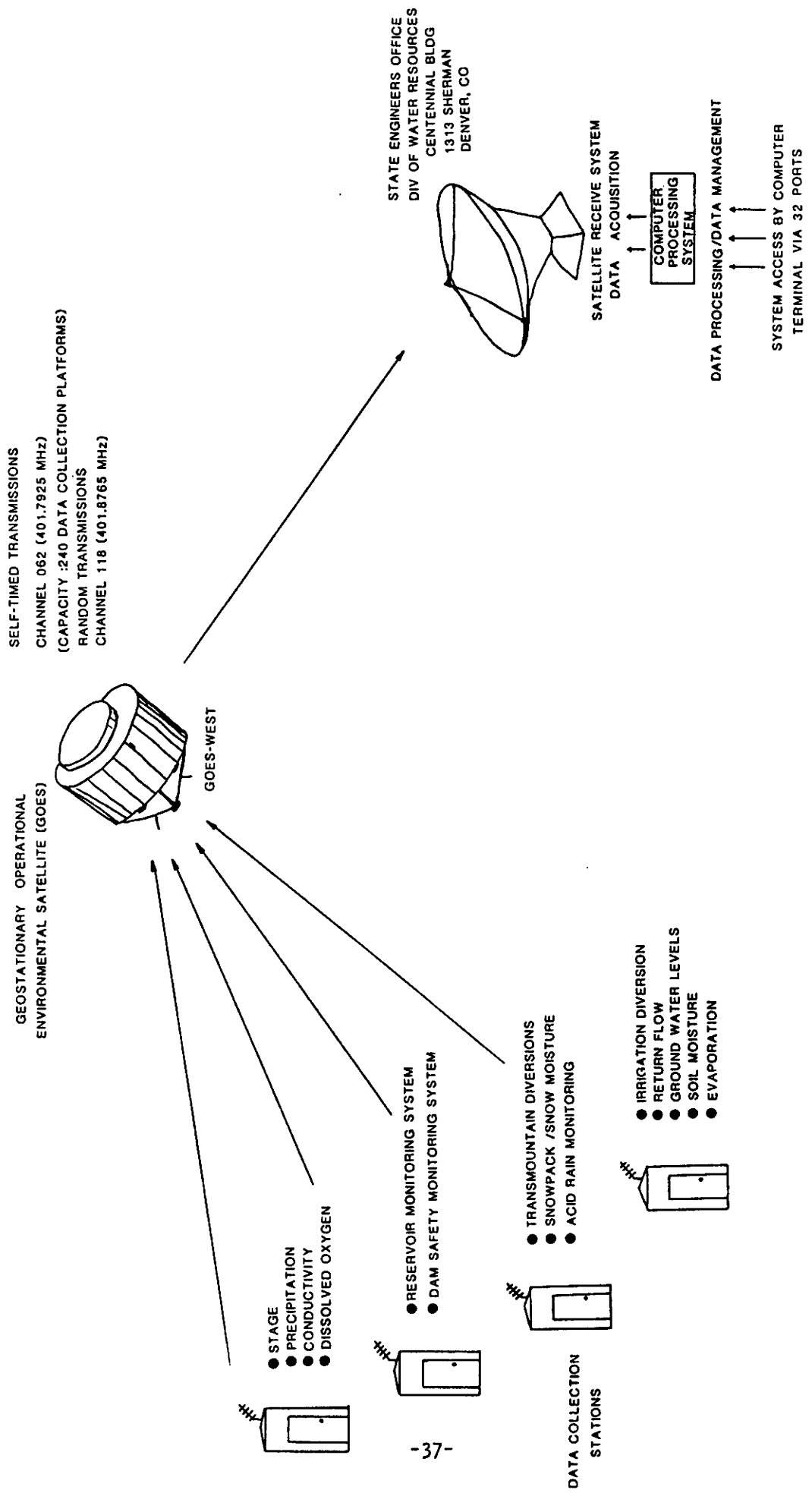

MONITORING SYSTEM CONFIGURATION

Figure 1

GOES SATELLITE RECEIVE SITE ELECTRONICS

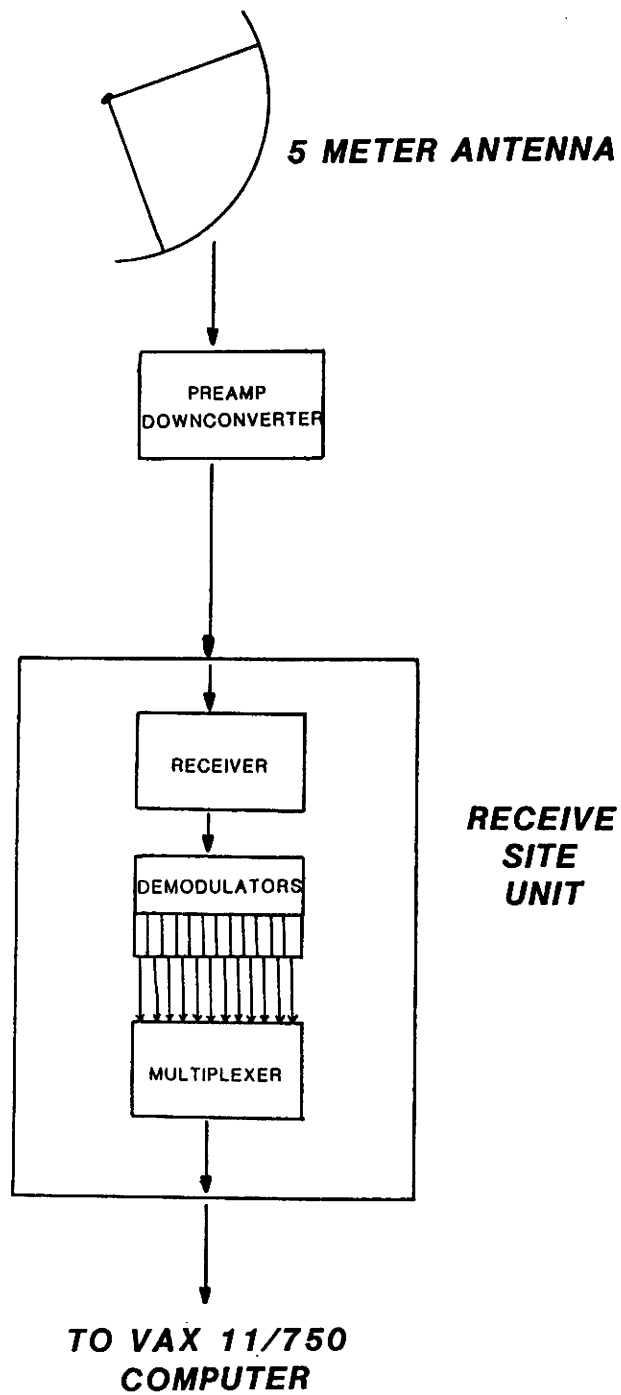

Figure 2

VAX 11/750 COMPUTER AND COMMUNICATIONS HARDWARE

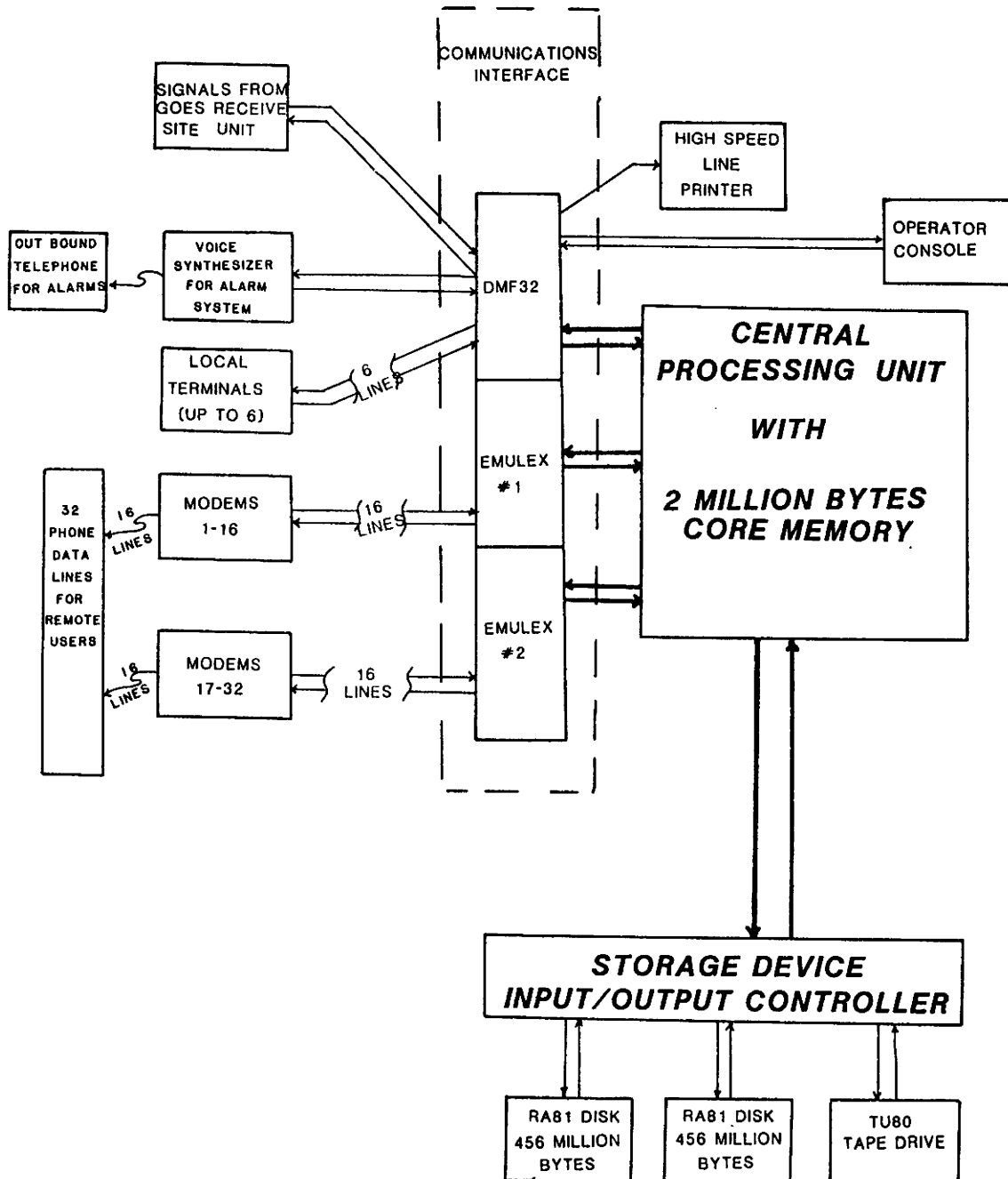
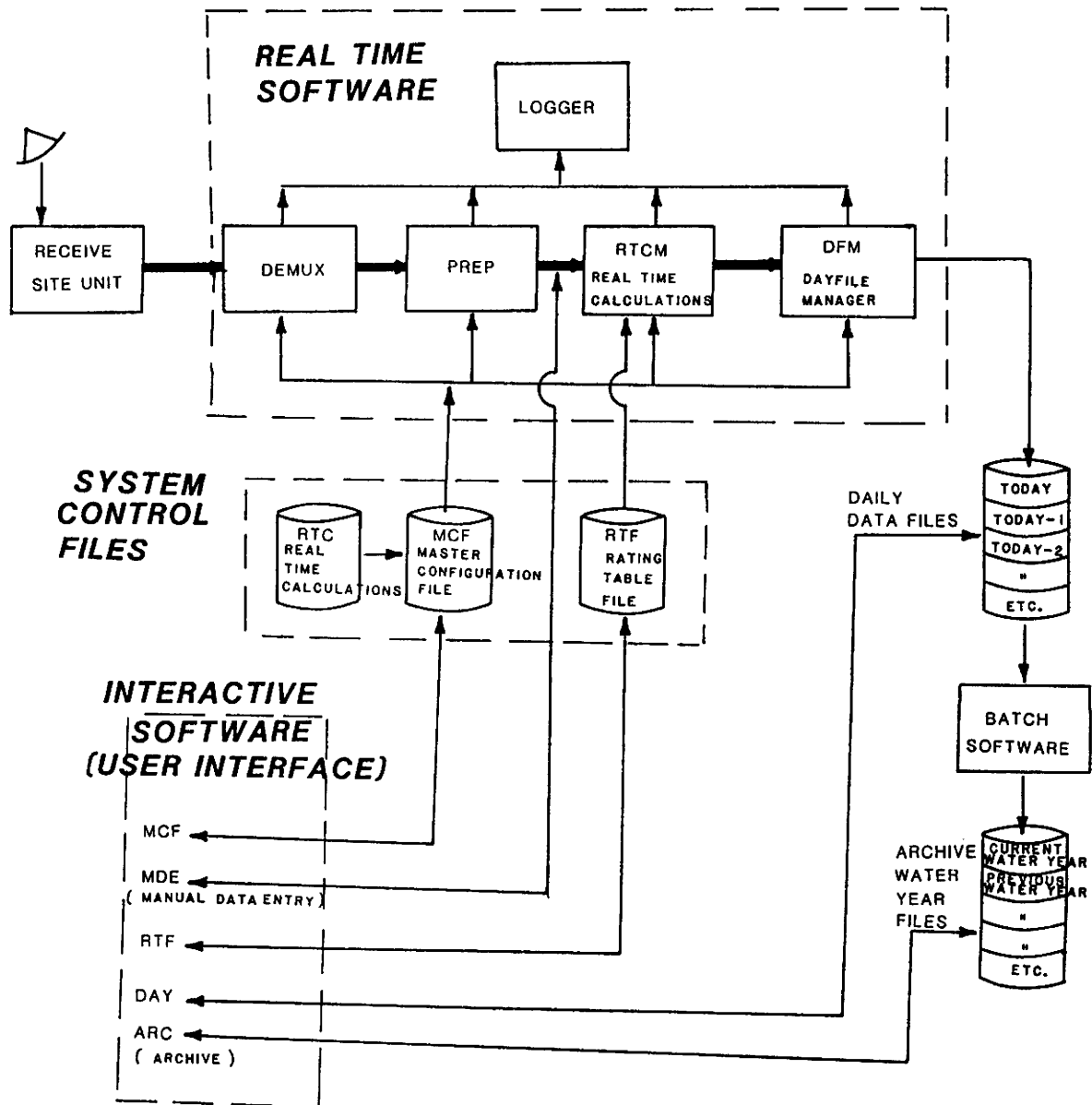

Figure 3

DWR DATA MANAGEMENT SYSTEM



THE OPERATION AND SCHEDULING OF ALL PROCESSES, INCLUDING USER ACCESS AND ACCOUNTING, IS CONTROLLED BY THE VAXVMS (VIRTUAL MEMORY SYSTEM) OPERATING SYSTEM

Figure 4

DAYFILES REPORT

STATION NAME	DATE	TIME	DATA TYPE	DATA VALUE	SHIFT	SHIFT VALUE
1 COLUTACO	JUN 15	00:00	# GAGE HT	7.88	# SHIFT	-0.04 #
			# DISCHRG	22800.00	#	
2 COLUTACO	JUN 15	01:00	# GAGE HT	7.91	# SHIFT	-0.04 #
			# DISCHRG	23000.00	#	
3 COLUTACO	JUN 15	02:00	# GAGE HT	7.91	# SHIFT	-0.04 #
			# DISCHRG	23000.00	#	
4 COLUTACO	JUN 15	03:00	# GAGE HT	7.93	# SHIFT	-0.04 #
			# DISCHRG	23000.00	#	
5 COLUTACO	JUN 15	04:00	# GAGE HT	7.93	# SHIFT	-0.04 #
			# DISCHRG	23000.00	#	
6 COLUTACO	JUN 15	05:00	# GAGE HT	7.90	# SHIFT	-0.04 #
			# DISCHRG	22900.00	#	
7 COLUTACO	JUN 15	06:00	# GAGE HT	7.91	# SHIFT	-0.04 #
			# DISCHRG	23000.00	#	
8 COLUTACO	JUN 15	07:00	# GAGE HT	7.86	# SHIFT	-0.04 #
			# DISCHRG	22800.00	#	
9 COLUTACO	JUN 15	08:00	# GAGE HT	7.88	# SHIFT	-0.04 #
			# DISCHRG	22800.00	#	
10 COLUTACO	JUN 15	09:00	# GAGE HT	7.87	# SHIFT	-0.04 #
			# DISCHRG	22800.00	#	
11 COLUTACO	JUN 15	10:00	# GAGE HT	7.86	# SHIFT	-0.04 #
			# DISCHRG	22800.00	#	
12 COLUTACO	JUN 15	11:00	# GAGE HT	7.81	# SHIFT	-0.04 #
			# DISCHRG	22600.00	#	
13 COLUTACO	JUN 15	12:00	# GAGE HT	7.86	# SHIFT	-0.04 #
			# DISCHRG	22800.00	#	
14 COLUTACO	JUN 15	13:00	# GAGE HT	7.82	# SHIFT	-0.04 #
			# DISCHRG	22600.00	#	
15 COLUTACO	JUN 15	14:00	# GAGE HT	7.83	# SHIFT	-0.04 #
			# DISCHRG	22600.00	#	
16 COLUTACO	JUN 15	15:00	# GAGE HT	7.79	# SHIFT	-0.04 #
			# DISCHRG	22500.00	#	
17 COLUTACO	JUN 15	16:00	# GAGE HT	7.82	# SHIFT	-0.04 #
			# DISCHRG	22600.00	#	
18 COLUTACO	JUN 15	17:00	# GAGE HT	7.84	# SHIFT	-0.04 #
			# DISCHRG	22700.00	#	
19 COLUTACO	JUN 15	18:00	# GAGE HT	7.84	# SHIFT	-0.04 #
			# DISCHRG	22700.00	#	
20 COLUTACO	JUN 15	19:00	# GAGE HT	7.89	# SHIFT	-0.04 #
			# DISCHRG	22900.00	#	
21 COLUTACO	JUN 15	20:00	# GAGE HT	7.91	# SHIFT	-0.04 #
			# DISCHRG	23000.00	#	
22 COLUTACO	JUN 15	21:00	# GAGE HT	7.99	# SHIFT	-0.04 #
			# DISCHRG	23300.00	#	
23 COLUTACO	JUN 15	22:00	# GAGE HT	8.04	# SHIFT	-0.04 #
			# DISCHRG	23500.00	#	
24 COLUTACO	JUN 15	23:00	# GAGE HT	8.04	# SHIFT	-0.04 #
			# DISCHRG	23500.00	#	

DAYFILES >

COLUTACO= Colorado River Near the Colorado-Utah Stateline

Figure 5

ARCHIVES REPORT

```

XXXXXXXXXXXXXXXXXXXXXXXXXXXXXXXXXXXXXXXXXXXXXXXXXXXXXXXXXXXXXXXXXXXXXXXXXXXX
XX
XX
XX
XX
XX
XX
XX
XX
XX
XX
XXXXXXXXXXXXXXXXXXXXXXXXXXXXXXXXXXXXXXXXXXXXXXXXXXXXXXXXXXXXXXXXXXXXXXXXXXXX
  
```

WATER YEAR 1986
** JUN **

COLUTACO

	SUN (1)	MON (2)	TUE (3)	WED (4)	THU (5)	FRI (6)	SAT (7)
COLUTACO	=====	=====	=====	=====	=====	=====	=====
DISCHRG	25100.48	25452.75	25194.88	27511.65	30157.28	30993.68	32063.67
GAGE_HT	8.46	8.54	8.48	9.03	9.58	9.75	9.96
SHIFT	-0.06	-0.06	-0.06	-0.05	-0.05	-0.05	-0.05
	(8)	(9)	(10)	(11)	(12)	(13)	(14)
COLUTACO	=====	=====	=====	=====	=====	=====	=====
DISCHRG	32942.50	31176.86	29227.04	26238.97	23511.54	22463.66	22747.17
GAGE_HT	8.43	9.78	9.39	8.73	8.05	7.79	7.86
SHIFT	-0.05	-0.05	-0.05	-0.05	-0.05	-0.04	-0.04
	(15)	(16)	(17)	(18)	(19)	(20)	(21)
COLUTACO	=====	=====	=====	=====	=====	=====	=====
DISCHRG	22881.46	23627.21	23656.99	23710.96	23655.93	23266.63	22088.70
GAGE_HT	7.89	8.07	8.08	8.08	8.06	7.95	7.65
SHIFT	-0.04	-0.04	-0.04	-0.03	-0.02	-0.01	0.00
	(22)	(23)	(24)	(25)	(26)	(27)	(28)
COLUTACO	=====	=====	=====	=====	=====	=====	=====
DISCHRG	21671.92	998877.00	998877.00	998877.00	998877.00	19543.46	19817.65
GAGE_HT	7.54	998877.00	998877.00	998877.00	998877.00	6.96	7.02
SHIFT	0.00	998877.00	998877.00	998877.00	998877.00	0.05	0.06
	(29)	(30)					
COLUTACO	=====	=====	=====	=====	=====	=====	=====
DISCHRG	19311.40	18841.98					
GAGE_HT	6.89	6.76					
SHIFT	0.06	0.07					

```

XXXXXXXXXXXXXXXXXXXXXXXXXXXXXXXXXXXXXXXXXXXXXXXXXXXXXXXXXXXXXXXXXXXXXXXXXXXX
  
```

ARCHIVES >

COLUTACO=Colorado River Near the Colorado-Utah Stateline
 Note: 998877 values are default flags where the actual data
 was outside of user determined normal range

Figure 6

ANNUAL REPORT

09163500 COLORADO RIVER NEAR COLORADO-UTAH STATE LINE

DISCHRG WATER YEAR OCTOBER 1985 TO SEPTEMBER 1986
MEAN VALUES

DAY	OCT	NOV	DEC	JAN	FEB	MAR	APR	MAY	JUN	JUL	AUG	SEP
1	7930.	6729.	---	5243.	6880.	7485.	13190.	16206.	25100.	18399.	7873.	5854.
2	7904.	6607.	---	5078.	6871.	7393.	14503.	18747.	25453.	17419.	7597.	5924.
3	7103.	6481.	---	5040.	6884.	7453.	16235.	21221.	25195.	16948.	7248.	5939.
4	6567.	6304.	---	5030.	6923.	7620.	14171.	23870.	27512.	16717.	7011.	5945.
5	6264.	6302.	---	4874.	6525.	7734.	12497.	26323.	30157.	18107.	6922.	5757.
6	6286.	6360.	---	4578.	6427.	7830.	11438.	26349.	30994.	20188.	6941.	5545.
7	6310.	6415.	---	4497.	6360.	7135.	10947.	24245.	32064.	19415.	6636.	5347.
8	7401.	6307.	---	4504.	6245.	6995.	11109.	23081.	32943.	17828.	6576.	5291.
9	10682.	6310.	---	4448.	6317.	7575.	11517.	21414.	31177.	17450.	6365.	5557.
10	9605.	6398.	---	4391.	6223.	8153.	11818.	20519.	29227.	17120.	6324.	6434.
11	9780.	6484.	---	4604.	5977.	7922.	11815.	19104.	26239.	16615.	5850.	7904.
12	10503.	6862.	---	4736.	5591.	7750.	11766.	18663.	23512.	15048.	5369.	7577.
13	10312.	7155.	---	4659.	5832.	7501.	12130.	18274.	22464.	14088.	5487.	7163.
14	9797.	7246.	---	5273.	6089.	7427.	12246.	17704.	22747.	14380.	5697.	6937.
15	8798.	7540.	---	6243.	6112.	7250.	11418.	17957.	22881.	14896.	5571.	6687.
16	8283.	7307.	---	6214.	6713.	7273.	11005.	19585.	23627.	14158.	5411.	6572.
17	7792.	7180.	---	6341.	6763.	7172.	11413.	20312.	23657.	14896.	5303.	6353.
18	7582.	7180.	---	6420.	6586.	7124.	11909.	19718.	23711.	14553.	5129.	6168.
19	7174.	7167.	---	6571.	6514.	6438.	11812.	18980.	23656.	13472.	4854.	6106.
20	7059.	7150.	---	6772.	7245.	6037.	11115.	19070.	23267.	13049.	4918.	6245.
21	7138.	7012.	---	6533.	7885.	5965.	10763.	21136.	22089.	13100.	4745.	6082.
22	7183.	6678.	---	6556.	7135.	5705.	11683.	23860.	21672.	12567.	5009.	5846.
23	7240.	6460.	---	6557.	6767.	5981.	13951.	25265.	20519.	12274.	5069.	5909.
24	7143.	---	---	6589.	6664.	6323.	16182.	26092.	19104.	11828.	5090.	6939.
25	7096.	---	---	6614.	6788.	6794.	16829.	25811.	18663.	11364.	5315.	8137.
26	7030.	---	5275.	6573.	7102.	7192.	17120.	25847.	18274.	10933.	5758.	8117.
27	7030.	---	5109.	6560.	7365.	7407.	16615.	27530.	19543.	10579.	5694.	8540.
28	7031.	---	5003.	6609.	7534.	7939.	15048.	28110.	19818.	9955.	5281.	7959.
29	7117.	---	4972.	6615.	---	8633.	14088.	28016.	19311.	9301.	5465.	8526.
30	7122.	---	5076.	6668.	---	9429.	14380.	27698.	18842.	8610.	5255.	8300.
31	7026.	---	5167.	6729.	---	10539.	---	25789.	---	8218.	5527.	---
TOTAL	241290.	155633.	30602.	178117.	186317.	229174.	390713.	696497.	646856.	351327.	181291.	199662.
MEAN	7784.	6767.	5100.	5746.	6654.	7393.	13024.	22468.	24879.	14053.	5848.	6655.
MAX	10682.	7540.	5275.	6772.	7885.	10539.	17120.	28110.	32943.	20188.	7873.	8540.
MIN	6264.	6302.	4972.	4391.	5591.	5705.	10763.	16206.	18842.	8218.	4745.	5291.

WTR YR 1986 TOTAL 3487480. MEAN 10797. MAX 32943. MIN 4391.

Note: Missing values in Nov-Dec are due to ice effects on Stage Sensor

Figure 7.

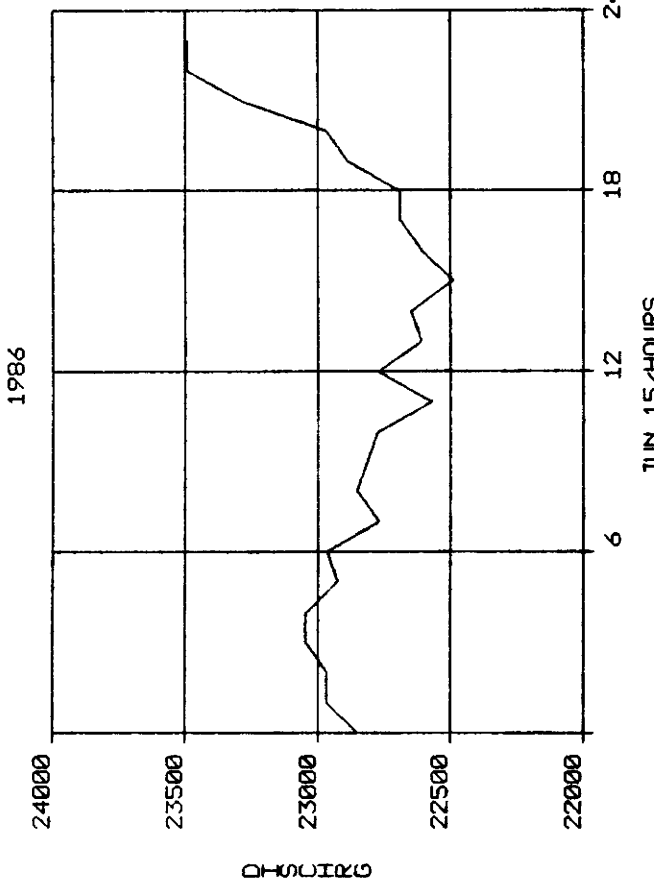

Figure 8
DAYFILES PLOT

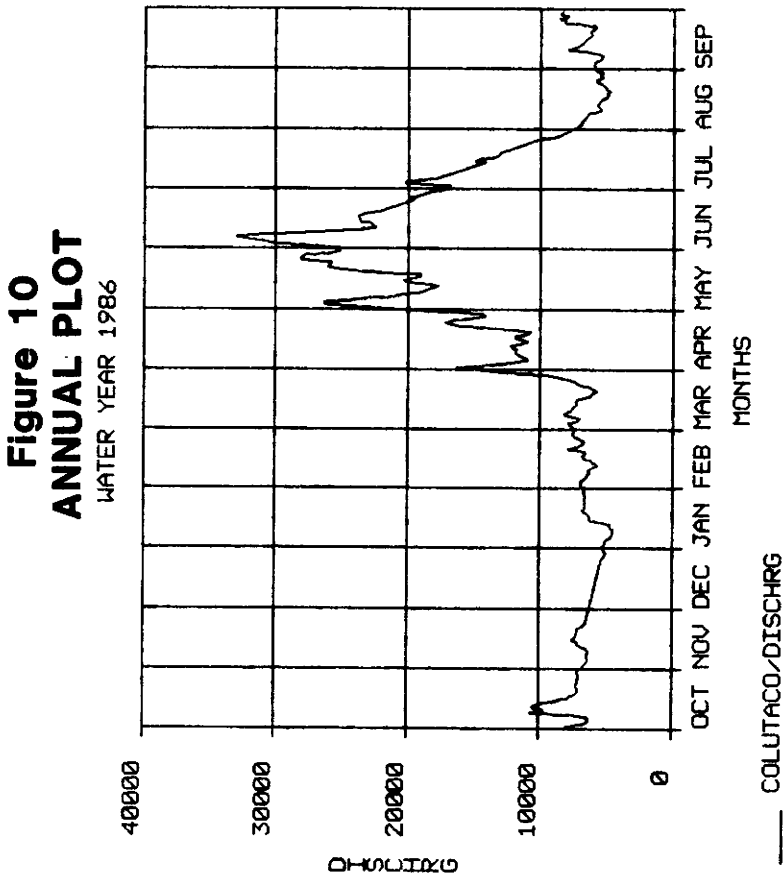

Figure 10
ANNUAL PLOT
WATER YEAR 1986

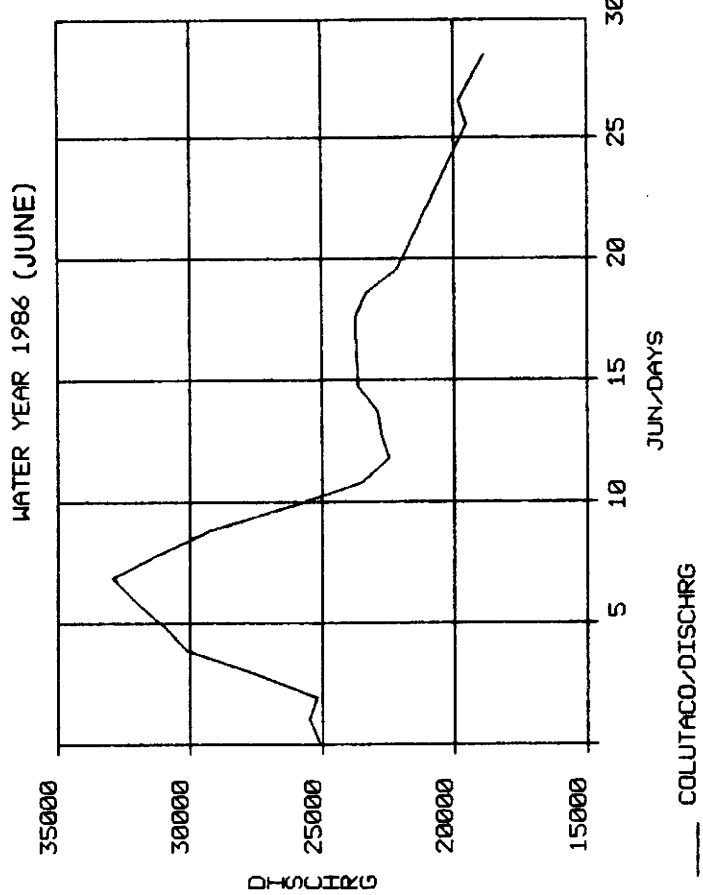

Figure 9
ARCHIVES PLOT

COLUTACO=Colorado River Near the
Colorado-Utah Stateline

SCHEMATIC

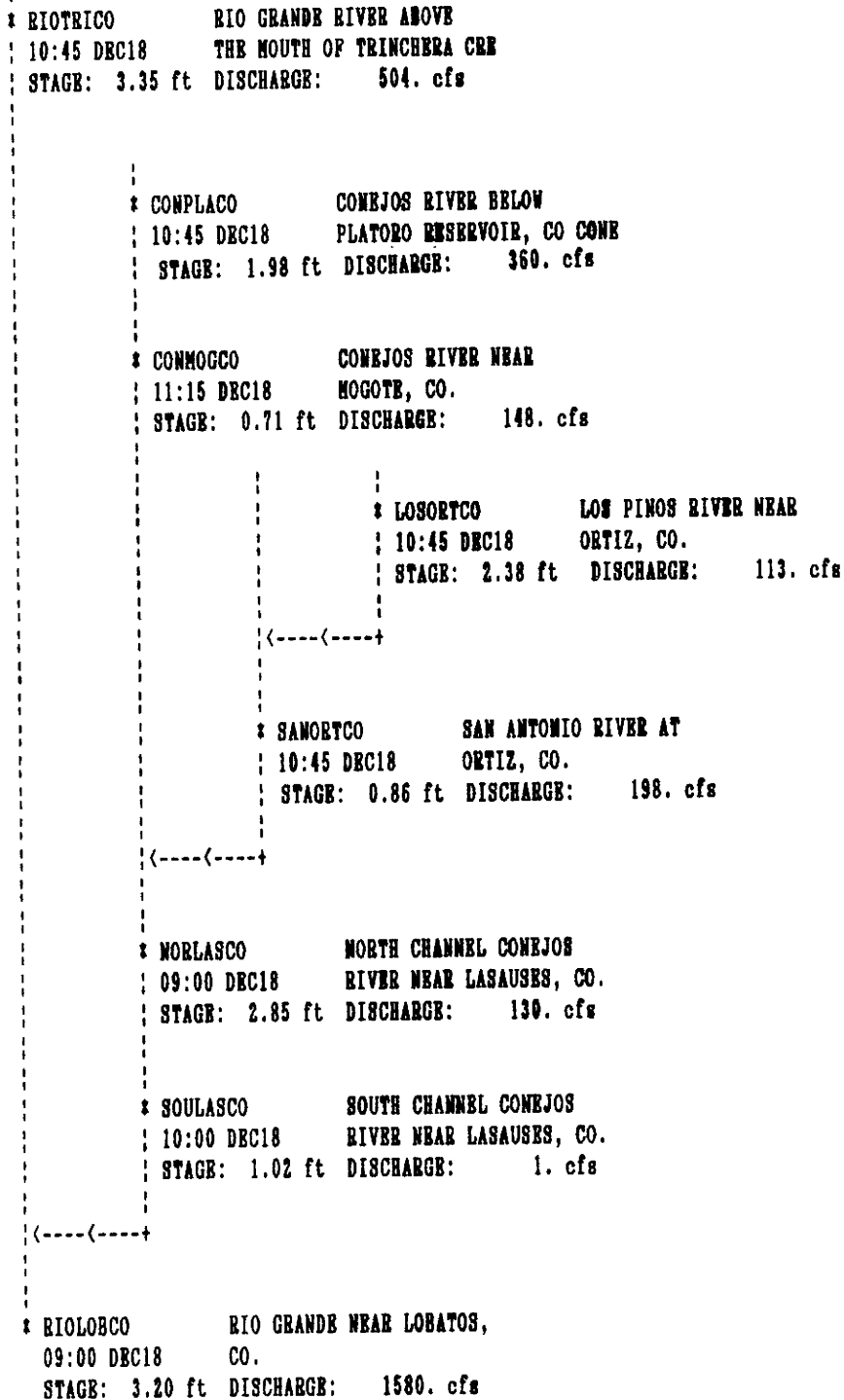

Figure 11

II. SYSTEM APPLICATIONS

A. Water Rights Administration

The primary utility of the Colorado satellite-linked monitoring system is for water rights administration. The availability of real-time data from a network of key gaging stations in each major river basin in Colorado provides an overview of the hydrologic conditions of the basin that was previously not available. By evaluating real-time data for upstream stations, downstream flow conditions can typically be predicted 24 to 48 hours in advance. This becomes an essential planning tool in the hands of the Division Engineers and Water Commissioners. The "river call" can be adjusted more precisely to satisfy as many water rights as possible. Access to real-time data makes it possible to adjust the "river call" to match dynamic hydrologic conditions. If additional water supplies are available, more junior rights can be satisfied. On the other hand, if water supplies decrease, then water use can be curtailed to protect senior rights.

The administration of water rights in Colorado is becoming increasingly more complex due to increased demands, implementation of augmentation plans, water exchanges, transmountain diversions, and minimum streamflow requirements. The number of water rights increased by 23% from 1982 to 1988, from 102,028 to 124,994. Plans for water rights transfers approved by the water courts are becoming increasingly complex. This is especially evident where agricultural water rights are transferred to municipal use. One point that must not be overlooked is that Colorado is coming out of a wet cycle. Historical and statistical evidence strongly indicate that Colorado can expect to experience a downturn in this cycle. As the availability of water decreases, the necessity of the system for water rights administration increases.

There is considerable interest in monitoring transmountain diversions, both by western slope water users and the eastern slope entities diverting the water. Transmountain diversion water is administered under different laws than water originating in the basin. In general, this water may be claimed for reuse by the diverter until it is totally consumed. Fourteen transmountain diversions are monitored by the system.

Water exchanges between water users are becoming increasingly frequent. These exchanges can provide for more effective utilization of available water resources in high demand river basins, but can be difficult to administer. The satellite-linked monitoring system has proven to be an integral component in monitoring and accounting of these exchanges.

Many municipalities and major irrigation companies have reservoir storage rights. Generally, these entities can call for release of stored water on demand. The Division Engineer must be able to delineate the natural flow from the storage release while in the stream. He then must track the release and ensure that the proper delivery is made. The system has demonstrated to be effective in this area.

The utility of the system in the administration of interstate compacts is an especially important application. The State Engineer has the responsibility to deliver defined amounts of water under the terms of the various interstate compacts, but not to over-deliver and deprive Colorado of its entitlement. Fifteen stations incorporated in the statewide monitoring network are utilized for the effective administration of these interstate compacts.

The majority of the large, senior water rights in Colorado belong to irrigation companies. These rights are often the calling right in the administration of a water district. The direct diversion rights exercised can affect significantly the hydrology of the river. Twenty-one major irrigation diversions are monitored by the system.

Water rights have been acquired by federal and state agencies to guarantee minimum streamflow for both the recreational and fisheries benefits. The availability of real-time data is essential in ensuring that these minimum streamflows are maintained.

B. Hydrologic Records Development

Specialized software programs provide for the processing of raw hydrologic data on a real-time basis. Conversions such as stage-discharge relationships and shift applications are performed on a real-time basis as the data transmissions are received. Mean daily values are computed automatically each day for the previous day. Data values that fall outside of user defined normal or expected ranges are flagged appropriately. Flagged data values are not utilized in computing mean daily values. Missing values can be added and invalid data values corrected by the respective hydrographer for that station using data editing functions. The records development software was significantly modified to allow for progressive records development. Computations are carried out by the computer alleviating the chance for human error.

Data can be retrieved and displayed in various formats including the standardized U. S. Geological Survey-Water Resources Division annual report format adopted by the Colorado Division of Water Resources for publication purposes. An advantage of real-time hydrologic data collection is in being able to monitor the station for on-going valid data collection. If a sensor or recorder fails, the hydrographer is immediately aware of the problem and can take corrective action before losing a significant amount of data.

It is essential to understand that real-time records can be different from the final record for a given station. This can be the result of editing raw data values because of sensor calibration errors, sensor malfunctions, analog-to-digital conversion errors, or parity errors. Discharge conversions can be modified by the entering of more current rating tables and shifts. Corrections to the data are sometimes necessary to compensate for hydrologic effects such as icing. Human error can also result in invalid data. The final record for those gaging stations operated by non-state entities, such as the U. S. Geological Survey-Water Resources Division, is the responsibility of that entity. Modifications to the real-time records for these stations are accepted by the state of Colorado.

C. Water Resources Accounting

There is a growing need for the ability to perform automated water resources accounting. Currently, the satellite-linked monitoring system is being utilized for such accounting for the Colorado-Big Thompson Project, the Dolores Project, and the Fryingpan-Arkansas Project Winter Water Storage. The ability to input real-time data into these accounting programs allows for current and on-going tabulations. Since the computations are performed on a computer, the accuracy is increased significantly.

D. Dam Safety

Dam safety monitoring has developed in recent years into a major issue. Numerous on-site parameters are of interest to the State Engineer in assessing stability of a dam. At this time, the system monitors seven reservoirs in Colorado. Currently, the parameters monitored are limited to inflow, outflow, and stage elevation. These data do, however, provide a basis for evaluating current operating conditions as compared to specific operating instructions. The installation and operation of additional sensor types could provide essential data on internal hydraulic pressure, vertical and horizontal movement, and seepage rates.

E. Automated Flood Warning System

The Office of the State Engineer, Division of Water Resources, in cooperation with the National Weather Service - Central Forecast Office (NWS-CFO) in Denver, operates a statewide flood warning system utilizing 78 stream gaging stations that are part of the Colorado satellite-linked water resources monitoring network operated by the State Engineer. The NWS-CFO, which operates on a 24-hour basis, is alerted to changing flow conditions. If conditions warrant, either a flood WATCH or a flood WARNING is issued.

Table 2 lists the incorporated stream gaging stations with the designated alert levels used to flag high water conditions. A synopsis of how the system operates follows:

1. Remote Data Collection/Data Transmission

Stream stage levels are measured and recorded every fifteen minutes for transmission at standard 4-hour intervals. If stage alert levels are surpassed, emergency transmissions are made at random intervals of from 2-10 minutes. All transmissions are sent via the Geostationary Operational Environmental Satellite. Transmissions are received and processed at the receive site located in Denver operated by the State Engineer.

2. Flagging High Water Levels

Data are screened in an automated fashion by the system's central computer to flag high water levels. The central computer automatically contacts the NWS-CFO by phone giving a voice-synthesized message that relays pertinent information. The transmission is not completed until the message is received and verified. A file is generated in the computer that lists all stations reporting high water levels during the last hour.

3. Hydrologic Conditions Assessment

The NWS-CFO OFFICIAL-IN-CHARGE (OIC) immediately accesses by computer terminal the satellite monitoring system data base to further evaluate overall upstream and downstream flow conditions for the effected watershed. Sophisticated software including color graphics capability allows the user to effectively evaluate the data. The OIC follows up by consulting with the NWS regional offices of Pueblo, Grand Junction, Colorado Springs, and Alamosa. Radar coverage is utilized to identify and determine the intensity of precipitation events. The appropriate county sheriff offices and official spotters are contacted for verification of hydrologic conditions.

4. Watch/Warning Dissemination

If flooding is considered a possibility, a WATCH is issued. If flooding is considered to be imminent, a WARNING is issued. The National Warning System (NAWAS), utilizing the Colorado State Highway Patrol and the Colorado Division of Disaster Emergency Services' (DODES) communications networks, is utilized to contact the various law enforcement agencies and county emergency preparedness offices. These agencies in turn provide a "fanout" to secondary points of contact including hospitals, schools, etc. Public announcements are made over the National Weather Service designated VHF-FM radio frequencies, known as the National Weather Radio (NWR), and through the news media via the Automation of Field Operations and Services (AFOS) national weather wire. In the Denver metropolitan area, the Metropolitan Emergency Telephone System (METS) is utilized.

It is important to comprehend inherent limitations of the satellite monitoring system relative to its utilization as a warning system. There are no absolute safeguards against false alarms. Sensor malfunctions are an obvious cause for such false alarms. However, the computer can be programmed to ignore data values that are not plausible. For example, stage values greater than 10 to 15 feet are not physically possible at most stream gaging stations. In the event of a flash flood in a narrow, confined canyon, the remote data collection hardware would be washed away. This is especially the case for a station operating downstream of a failed dam. Ice jams on a river can cause the upstream stage to increase and consequently provide invalid discharge conversions. There is always a time lapse from the time a hydrologic event occurs to when the system identifies that it has occurred and when a random (emergency) transmission is sent. If an event occurs at 1410 hours, the system is not aware of the condition until 1415 hours since the DCP is programmed to activate at even 15-minute intervals to record a data measurement. The DCP then computes a transmit interval utilizing a random number generator. This interval is between 2 and 10 minutes. If a 6-minute interval is utilized, the random transmission will be made at 1421 hours. The elapsed time from event occurrence to transmission of data is 13 minutes. Scenarios could be given which would give a minimum elapse time of two minutes or a maximum elapse time of 24 minutes. In addition, a random transmission occurring on channel 118W has approximately a 20% chance (with current channel load levels) of not being received due to interference with another random transmission being sent at the same time.

F. Future Applications

Any data that can be collected remotely can be monitored by the satellite-linked monitoring system. Future applications, based primarily on current sensor capabilities, are likely to be in the areas of runoff forecasting, water quality monitoring, and in irrigation planning. Runoff forecasting will require the addition of sensor configurations capable of monitoring liquid and frozen precipitation, air temperature, solar radiation, and soil moisture. Water quality monitoring covers an extremely wide spectrum but would likely consist of a sensor configuration capable of monitoring conductivity (total dissolved solids), water temperature, dissolved oxygen, and turbidity. Irrigation planning would require a sensor configuration capable of monitoring humidity, precipitation, soil moisture, soil temperature, air temperature, wind velocity and azimuth, evaporation rates, and solar radiation.

TABLE 2
SATELLITE MONITORING SYSTEM
FLOOD WARNING NETWORK

<u>STATION</u>	<u>ALERT LEVEL (FT)</u>	<u>DISCHARGE (CFS)</u>
<u>Division 1 / South Platte River Basin</u>		
1. Bear Creek at Morrison	5.50	345
2. Clear Creek at Golden	4.00	345
3. Boulder Creek near Orodell	3.50	590
4. St. Vrain Creek at Lyons	5.60	1,610
5. North Fork Big Thompson near Drake	4.60	172
6. Cache La Poudre at Canyon Mouth near Fort Collins	4.50	2,000
7. South Platte River at Denver	6.00	3,930
8. South Platte River at Henderson	9.00	4,450
9. South Platte River near Kersey	7.00	6,560
10. South Platte River near Weldona	7.00	4,200
11. South Platte River near Balzac (Channel-South)	7.00	2,230
12. South Platte River near Julesburg (Channel-Right)	7.00	4,280
13. Cache La Poudre at Greeley	7.00	2,500
14. Big Thompson River at Mouth of Canyon	5.00	2,400
<u>Division 2 / Arkansas River Basin</u>		
1. Arkansas River near Wellesville	7.90	5,000
2. Fountain Creek near Pinon	6.53	5,020
3. Arkansas River near Avondale	5.00	5,000
4. Arkansas River below Catlin Dam	7.70	10,000
5. Purgatoire River near Thatcher	11.30	10,040
6. Purgatoire River at Las Animas	8.00	2,910
<u>Division 3 / Rio Grande Basin</u>		
1. Alamosa Creek above Terrace Reservoir	3.50	1,480
2. Conejos River below Platoro Reservoir	3.75	1,085
3. Conejos River near Mogote	5.25	2,970
4. La Jara Creek near Capulin	4.05	211
5. Los Pinos River near Ortiz	6.25	1,840
6. Rio Grande near Del Norte	5.10	7,060
7. Rio Grande at Thirty-Mile Bridge	4.70	2,700
8. South Fork Rio Grande at South Fork	6.60	3,280
9. Saguache Creek near Saguache	4.50	540
10. San Antonio River at Ortiz	5.00	1,000
11. Rio Grande at Alamosa	8.00	3,000
12. Conejos River near La Sauses (North Channel)	6.00	1,550
13. Rio Grande near Monte Vista	7.50	5,000

FLOOD WARNING NETWORK (cont.)

<u>STATION</u>	<u>ALERT LEVEL (FT)</u>	<u>DISCHARGE (CFS)</u>
<u>Division 4 / Gunnison River Basin</u>		
1. Cimarron River near Cimarron	5.40	1,050
2. East River at Almont	7.00	3,000
3. Gunnison River at Delta	11.30	18,500
4. Gunnison River near Grand Junction	12.85	20,540
5. Gunnison River near Gunnison	5.00	5,760
6. Kannah Creek near Whitewater	2.50	660
7. Leroux Creek near Lazear	4.50	910
8. Muddy Creek above Paonia Reservoir	7.90	2,680
9. Muddy Creek below Paonia Reservoir	7.20	2,580
10. North Fork Gunnison River near Somerset	7.25	7,000
11. Surface Creek at Cedaredge	3.20	590
12. San Miguel River at Naturita	7.00	4,600
13. San Miguel River near Placerville	6.00	
14. Smith Fork near Crawford	8.00	1,140
15. Surface Creek near Cedaredge	3.40	630
16. Taylor River at Almont	4.25	2,015
17. Uncompahgre River at Colona	5.00	2,970
18. Uncompahgre River near Ridgway	4.95	1,550
19. Dallas Creek near Ridgway	5.20	540

Division 5 / Colorado River Basin

1. Willow Creek below Willow Creek Reservoir	5.30	1,260
2. Colorado River at Hot Sulphur Springs	4.65	4,200
3. Williams Fork below Williams Fork Reservoir	5.90	1,950
4. Blue River below Dillon	3.80	1,840
5. Blue River below Green Mountain Reservoir	9.10	2,820
6. Eagle River below Gypsum	8.80	5,850
7. Colorado River near Dotsero	11.70	16,120
8. Fryingpan River near Ruedi	3.70	1,240
9. Fryingpan River near Thomasville	4.20	1,290
10. Rifle Gap below Rifle Gap Reservoir	2.60	90
11. Colorado River near Kremmling	10.00	3,800

Division 6 / Green River Basin

1. Elk River at Clark	5.90	4,500
2. Yampa River near Oak Creek	4.60	1,500
3. Yampa River at Steamboat Springs	6.00	4,500
4. Yampa River near Maybell	7.00	7,000
5. White River near Meeker	3.90	4,150

FLOOD WARNING NETWORK (cont.)

	<u>STATION</u>	<u>ALERT LEVEL (FT)</u>	<u>DISCHARGE (CFS)</u>
<u>Division 7 / Dolores & San Juan River Basins</u>			
1.	Rio Blanco below Blanco Diversion Dam	4.37	1,000
2.	Navajo River below Oso Diversion Dam	4.80	1,200
3.	Dolores River at Dolores	6.40	4,050
4.	Lost Canyon Creek near Dolores	6.10	500
5.	La Plata River at Hesperus	3.88	800
6.	La Plata River at Colorado-New Mexico Stateline	3.60	800
7.	Mancos River near Mancos	4.00	900
8.	Florida River above Lemon Reservoir	3.90	1,000
9.	Florida River below Lemon Reservoir	5.00	970
10.	San Juan River at Pagosa Springs	8.00	7,620
11.	Animas River at Durango	6.50	6,120

III. OPERATING BUDGET

A. FY 87-88 Operating Costs

The actual operating cost of the satellite-linked monitoring system for FY 87-88 was \$184,999. The projected budget was \$228,741. Available funds amounted to \$187,732. A detailed breakdown of expenditures is given in Table 3. \$43,343 in necessary spending restraints was required. Approximately 88% of the spending reductions were under four line items:

<u>ITEM</u>	<u>REDUCTIONS</u>
<u>FIXED EXPENSES</u>	
II-D. Scheduled Maintenance	\$12,729
This basically involves preventive maintenance and calibration of remote data collection hardware and sensors.	
II-B. Telecommunications	\$ 9,093
Long-distance phone access by water commissioners was restrained.	
III. Indirect Cost Assessment	\$ 6,293
The Department of Natural Resources applies an assessment against cash funds to cover administrative overhead.	
<u>VARIABLE EXPENSES</u>	
I. Operating Costs	\$10,343
Training, travel and per diem, and hardware service costs are included in this category.	

It is necessary to point out that certain indirect costs in operating the system are also realized. These indirect costs are absorbed by the Division of Water Resources. These indirect costs, amounting to an estimated \$86,240 per year, are as follows:

1. Manpower to maintain the monitoring network 7 divisions/30 hours per month @ \$12 per hour	\$30,240
2. Travel costs to maintain remote data collection hardware	\$14,000
3. Office space and secretarial support for 2 FTE's \$1,000 per month	\$12,000

4. Computer room and utilities for VAX 11/750 computer \$1,000 per month	\$12,000
5. Support from the Information Services Branch \$1,000 per month	\$12,000
6. Administrative costs \$500 per month	\$ 6,000

B. FY 88-89 and FY 89-90 Budgets

The projected operating cost of the system for FY 88-89 is \$248,649. The projected operating cost of the system for FY 89-90 is \$253,021. A detailed breakdown of these costs is given in Table 4.

C. Future Budget Considerations

There are indications that in the future user fees will be charged by NOAA-NESDIS to offset the costs of operating the GOES DCS. These user fees may be assessed as early as 1990, coinciding with the launch of the next generation of GOES spacecraft and the activation of the NOAA-NESDIS Automatic Data Processing System. There is no estimate as to the possible range of user fees.

The new generation of GOES spacecraft may utilize transmission relay rates of 300 bits per second (bps) over the present rate of 100 bps. This would require modifications to the existing DCP transmitters. If the modification cost were to range from an estimated \$200 to \$400 per unit, the total cost to modify the 166 units operated by the state of Colorado would amount to \$33,200-\$66,400.

There is a concern over short-term and long-term hardware replacement costs. On the short term (24 to 48 months), replacement will be primarily due to damaged/vandalized hardware. Current replacement cost for the GOES-linked data collection hardware installed at a single station is approximately \$5,500. If 5% of the hardware had to be replaced in a given year, the cost would be \$41,500. This exceeds budgeted amounts by \$25,000. On the long-term (48 to 72 months), consideration must be given to blanket replacement of hardware. The effective lifetime of a DCP is expected to be between 6 to 8 years (as per the manufacturer, the Sutron Corporation). DCP's operated by the state of Colorado will reach this in the 1990 to 1992 period. The cost to replace 166 DCP's is currently \$481,400.

An additional FTE should be seriously considered to work on the program. The position, System Maintenance Manager, would be responsible for both coordinating and carrying-out the sustained operation and maintenance of the remote data collection network. As the system becomes more integrated into real-time water rights administration, there develops a greater need to maintain the operation of the monitoring network on a continuous and consistent basis. Demands on designated Division staff to maintain the remote data collection hardware have become a burden as their primary hydrographic duties have increased dramatically. This position would add an estimated \$40,000 to the budget.

TABLE 3
SATELLITE MONITORING SYSTEM
FY 87-88 BUDGET

<u>ITEM</u>	<u>FY 87-88</u> (projected)	<u>FY 87-88</u> (actual)
<u>FIXED EXPENSES</u>		
I. PERSONNEL COSTS	\$95,919	\$95,848
II. OPERATING COSTS	83,072	59,742
A. Hardware Maintenance Contracts	15,508	16,005
B. Telecommunications	43,264	34,171
C. Computer Operations	5,000	2,795
D. Scheduled Maintenance	19,300	6,571
III. INDIRECT COST ASSESSMENT	<u>12,600</u> \$191,591 (88%)	<u>6,307</u> \$161,897 (84%)
<u>VARIABLE EXPENSES</u>		
I. OPERATING COSTS	\$21,250	\$10,907
A. Travel and Per Diem	6,250	4,167
B. Training	5,500	2,111
C. Hardware Service	5,500	2,081
D. Other Operating Costs	4,000	2,548
II. CAPITAL OUTLAY	15,500	12,195
A. Hardware Replacement	10,000	8,136
B. System Enhancement	<u>5,500</u> \$36,750 (12%)	<u>4,059</u> \$23,102 (16%)
TOTALS	\$228,341	\$184,999

TABLE 4

SATELLITE MONITORING SYSTEM
 FY 88-89 AND FY 89-90 BUDGETS

<u>ITEM</u>	<u>FY 88-89</u> (projected)	<u>FY 89-90</u> (projected)
<u>FIXED EXPENSES</u>		
I. PERSONNEL COSTS	\$98,251	\$98,422
II. OPERATING COSTS	100,901	106,855
A. Hardware Maintenance Contracts	19,834	20,115
B. Telecommunications	52,596	56,231
C. Computer Operations	6,173	7,213
D. Scheduled Maintenance	22,298	23,296
III. INDIRECT COST ASSESSMENT	<u>12,243</u>	<u>13,944</u>
	\$211,395 (85%)	\$219,221 (87%)
<u>VARIABLE EXPENSES</u>		
I. OPERATING COSTS	\$15,996	\$17,720
A. Travel and Per Diem	3,858	4,295
B. Training	4,492	4,797
C. Hardware Service	4,133	4,693
D. Other Operating Costs	3,513	3,935
II. CAPITAL OUTLAY	21,258	16,080
A. Hardware Replacement	11,246	10,080
B. System Enhancement	<u>10,012</u>	<u>6,000</u>
	\$37,254 (15%)	\$33,800 (13%)
TOTALS	\$248,649	\$253,021

IV. FUNDING SOURCES

A. FY 87-88 Funding

Ninety-four thousand three hundred sixty-nine dollars (\$94,369) was appropriated from the General Fund for the operation of the satellite-linked monitoring system in FY 87-88. A total of \$282,997 was approved for total program expenditures. The remaining \$188,628 was to be collected from user fees, pursuant to Section 37-80-111.5(c), C.R.S. (1985 Supplement).

In FY 87-88, fees amounting to \$93,400 were collected as compared to \$94,800 in FY 86-87, and \$100,900 in FY 85-86. The following is a summary of the fees collected in FY 87-88:

Southeastern Colorado Water Conservancy District	\$35,000
Colorado River Water Conservation District	15,000
Arkansas River Compact Commission	7,000
Dolores Water Conservancy District	6,500
Southwestern Water Conservation District	6,000
Bureau of Reclamation (San Juan Chama Project)	2,400
City of Denver	2,400
Animas-La Plata Water Conservancy District	1,800
Bureau of Reclamation-Montrose Projects Office	1,700
City of Aurora	1,600
Urban Drainage District	1,200
Central Colorado Water Conservancy District	1,200
Farmer's Reservoir and Irrigation Company	1,200
Denver Metro Sewage Disposal District	1,200
Rio Grande Canal Water Users Association	1,200
Lower South Platte Water Conservancy District	1,200
Henrylyn Irrigation District	1,000
Conejos Water Conservancy District	1,000
Santa Maria Reservoir Company	700
Florida Water Conservancy District	600
Mancos Water Conservancy District	600
City of Durango	600
Pine River Irrigation District	600
Uncompaghre Valley Water Users Association	600
Colorado-Ute Electric Association	600
West Divide Water Conservancy District	500
TOTAL	<u>\$93,400</u>

Total funds available for FY 87-88 was \$208,557. A summary of the funding is as follows:

Fund balance from FY 85-86 through FY 86-87	\$20,825
General Fund with POTS	94,369
User Fees (Actual)	<u>93,363</u>
TOTAL	<u>\$208,557</u>

Actual expenditures for FY 87-88 amounted to \$184,999 leaving a fund balance of \$23,558. The fund balance is an accumulation of unspent year-end funds going back to FY 85-86. The amount of fees that are collected in any given year varies. Fees are also received throughout the year rather than at the beginning of the year. Efforts are maintained so as not to overspend against available funds. In addition, a fund of \$25,000 to \$35,000 is considered necessary to handle possible emergency expenditures.

B. FY 88-89 Funding

Ninety-two thousand six hundred sixty-three dollars (\$92,663) was appropriated from the General Fund for the operation of the satellite-linked monitoring system for FY 88-89. A total of \$248,649 was approved for total program expenditures. A total of \$155,986 in user fees will be required to meet the projected budget. This excludes use of the existing fund balance of \$23,558. Fee collections are projected to be \$111,150 in FY 88-89. The increased amount is due to additional service fees related to the receive/processing of transmissions from non-state operated Data Collection Platforms and a contribution of \$7,500 from the Northern Colorado Water Conservancy District.

C. FY 89-90 Funding

A budget request was submitted to the Joint Budget Committee of the General Assembly to increase the General Fund appropriation for the operation of the monitoring system to \$124,897 in FY 89-90. Based on a projected budget of \$253,021, this would leave \$128,124 to be collected from user fees.

D. User Fee Requirements by Division

Based on an operating budget of \$248,649 for FY 88-89, the cost to operate and maintain a single satellite-linked gaging station is \$1,657 per year. The costs to operate the seven subnetworks, identified by river basin/division, are as follows:

<u>Basin</u>	<u>Water Division</u>	<u>Number of Stations</u>	<u>Cost to Operate</u>
South Platte	1	34	\$56,360
Arkansas	2	43	71,279
Rio Grande	3	18	29,837
Gunnison	4	11	18,235
Colorado	5	22	36,468
White/Yampa	6	7	11,605
Dolores/San Juan	7	15	24,865

Based on user fee requirements of \$155,965, the relative user fee requirements by basin/division and the net differences based on projected fee collections are as follows:

<u>Basin</u>	<u>Water Division</u>	<u>User Fee Requirements</u>	<u>Projected Fee Collection</u>	<u>Net Difference</u>
South Platte	1	\$ 35,357	\$ 22,250	-\$13,107
Arkansas	2	44,716	42,000	- 2,716
Rio Grande	3	18,718	2,900	- 15,818
Gunnison	4	11,439	10,250	- 1,189
Colorado	5	22,878	10,750	- 12,586
White/Yampa	6	7,279	2,700	- 4,579
Dolores/San Juan	7	<u>15,599</u>	<u>20,300</u>	+ <u>4,701</u>
TOTALS		\$155,986	\$111,150	-\$45,294

E. Future Funding Considerations

The water user community has expressed the opinion that the administration of the state's water resources is a public responsibility. The satellite monitoring system is effectively being utilized in daily water rights administration, hydrologic records development, flood monitoring, water resources accounting, and in the administration of interstate compacts. All of these tasks are carried out for the benefit of the public. By having the entire operating budget allocated from the General Fund, the cost of operating the system can be borne by all water users while ensuring its continued operation. It is important to understand that approximately 70% of cash funds are contributions rather than user access fees or service fees.

The satellite monitoring system represents a \$1,800,000 investment by the state of Colorado to apply space-age technology to the administration and management of the state's most valuable natural resource. The allocation of General Funds to operate the system will provide all interested users the opportunity to directly utilize the system's capabilities, which is a primary objective of the Office of the State Engineer. Non-Colorado water users, i.e. the state of Kansas, will be provided access only on a user fee basis. Users being provided with special services, i.e. the receiving and processing of data transmissions from privately operated data collection hardware, will still be required to pay for the actual cost of those services.

A major thrust in marketing the satellite-linked monitoring system is in the integration of the system into the operations of other state agencies. Discussions have been held with the Division of Wildlife, Department of Health, and the Water Conservation Board, to determine what needs can be met through the utilization of the monitoring system. Increased General Fund appropriations can be more easily obtained if more broad based, interagency utilization can be achieved.

V. COST-BENEFIT CRITERIA

It is estimated that the Colorado satellite-linked water resources monitoring system provides benefits to the state of Colorado amounting to between \$1,337,000 and \$1,505,000 per year. These benefits will increase as the system becomes further assimilated into the statewide administration and management of water resources. Benefits will also increase dramatically during periods of water shortages as compared to current periods of water surpluses. Since the cost to operate the system in FY 87-88 was \$271,239 (\$184,999 in direct costs and \$86,240 in indirect costs), the net benefit to the state of Colorado is between an estimated \$1,057,000 and \$1,225,000. If the original capital cost of the system of approximately \$1,500,000 is amortized simply over a 5-year period, net benefits realized are between an estimated \$757,000 and \$925,000 per year.

Direct and indirect benefits are calculated as follows:

1. Approximately \$5,300,000 per year is budgeted by the Office of the State Engineer for statewide water rights administration. If the operation of the satellite-linked monitoring system conservatively increases effectiveness by 10%, that equates to a benefit of \$530,000 per year. Direct benefits are attained by water commissioners having more time for water administration and reduction in over-time to accomplish ever increasing workloads. Indirect benefits relate to the ability to be more effective in water rights administration. This leads to greater cooperation among water users and fewer legal problems.

Despite the fact that the number of water rights increased from 102,028 in 1982 to 124,994 in 1988 (increase of 23%), the number of water commissioners decreased from 94 to 93. These statistics indicate that based strictly on the number of water rights, the number of water commissioners should have increased by twenty-three. We must also consider the increased workload due to the growing complexity being incorporated recently into water rights administration. The monitoring system cannot be expected to replace the need for twenty-three additional water commissioners, but can compliment a moderate increase in water commissioners. If the system can potentially eliminate the need for ten additional water commissioners, savings may be an estimated \$350,000 to \$400,000 annually. The responsibility of water rights administration is a statutory responsibility given to the State Engineer. The necessary personnel and tools to carry out this responsibility must also be provided.

2. It is calculated that in an average year, between 42,000 and 56,000 acre-feet of water can be saved for use in Colorado through utilization of the system. At a conservative price of \$12.00 per acre-foot of water, this amounts to between \$504,000 and \$672,000 per year. In years of water scarcity, the amount that is actually saved for consumption may vary but the value of the water would naturally be higher.

3. Cost savings in the area of hydrologic records development are calculated to be \$69,600 per year.
 - a. Automated data processing and data entry
150 stations/2 hours per month @ \$12 per hour \$43,200
 - b. Data archiving and retrieval
\$1,000 per month \$12,000
 - c. Cost of lost data
150 stations/8 hours per year @ \$12 per hour \$14,400
4. Water resources accounting programs utilizing the system have been set up for the Dolores Project, the Colorado-Big Thompson Project, and the Fryingpan-Arkansas River Project. Savings are estimated to be 40 hours per month @ \$12 per hour or \$5,760 per year.
5. The benefits attributed to the system from flood warning are calculated to be \$175,000 per year. If a real-time flood monitoring network of 50 stations is considered essential, and the operating cost for each station is \$3,500 per year, this amounts to \$175,000 per year.
6. An estimated \$53,400 per year is saved in reduced manpower and travel costs in manually reading stream gages.
 - a. Manpower savings
150 stations/8 hours per month @ \$12 per hour \$14,400
 - b. Travel savings
150 stations/1 trip per week
25 miles per trip @ \$0.20 per mile \$39,000

VI. EFFECTS OF LOSS OF FUNDING FOR FY 88-89

The satellite-linked water resources monitoring system, without adequate funding, would not be able to function satisfactorily and would likely be deactivated within eighteen months. The system is an integration of various essential components that cannot function with the loss of any one of those components. This would effectively mean the loss of a \$1.5 million investment by the state of Colorado.

The FY 88-89 budget of \$248,649 is broken down into two categories; fixed expenses amounting to \$211,395, and variable expenses amounting to \$37,254. The variable expense items are 15% of the budget and would be the first cuts made. These cuts would mean curtailment of:

1. Long-distance phone access by the water commissioners.
2. Repair of malfunctioning remote data collection hardware.
3. Replacement of damaged, vandalized, or stolen remote data collection hardware.
4. Timely maintenance and calibration of remote data collection hardware.
5. Training for system users relative to data base access and software utilization.
6. Travel to Division offices, system users, and cooperating Federal agencies.

Fixed expense items would be the second area for budget cuts. The effects of these cuts would be as follows:

1. Personnel eliminations

Two full-time employees would be eliminated from the program, the Program Manager and the System Analyst. The effects of the elimination of the Program Manager position would include the following:

- a. The loss of statewide interagency coordination.
- b. The loss of intra-agency coordination.
- c. The loss of coordination with system users.
- d. The loss of coordination in network expansion.
- e. The loss of coordination in system enhancement.
- f. The loss of coordination in system operation and utilization.

The effects of the elimination of the System Analyst position would be as follows:

- a. The loss of coordination in central computer and Division personal computer utilization.
- b. The loss of coordination in data base management.
- c. The loss of coordination of data base access and software utilization.
- d. The loss of coordination in software development.

2. Elimination of system maintenance contracts.
3. The elimination of telecommunications access to the system.

The resultant cumulative effects on the general operations of the system would be as follows:

1. During the first twelve months, an estimated 20%, or thirty of the remote data collection stations, would be taken off-line due to malfunctioning, damaged, or stolen hardware. There would be a deliberate effort to maintain subnetworks that have received operations and maintenance subsidies (user fees).
2. As a result of the above, the state of Colorado would have thirty transmission slots on GOES revoked by the NOAA-NESDIS due to inactivity.
3. Maintenance of remote data collection hardware would face 2-3 week delays.
4. Data quality would deteriorate.
5. Down-time of the Direct Readout Ground Station and central computer would be in excess of six weeks per year.
6. As the system became less dependable, it would be utilized less and less.
7. Hydrologic records would cease to be developed on the system requiring manual records development.
8. Real-time data would not be available requiring additional staff and travel to manually read remote gages.

VII. SYSTEM USERS

The following is a list of users of the satellite-linked water resources monitoring system:

A. Office of the Colorado State Engineer

1. Division of Water Resources
 - a. Division 1, Greeley
 - b. Division 2, Pueblo
 - c. Division 3, Alamosa
 - d. Division 4, Montrose
 - e. Division 5, Glenwood Springs
 - f. Division 6, Steamboat Springs
 - g. Division 7, Durango
 - h. Central Office, Denver
2. Water Commissioners

B. Water Conservancy Districts/Irrigation Districts

1. Southeastern Colorado Water Conservancy District
2. Lower South Platte Water Conservancy District
3. Colorado River Water Conservation District
4. Southwestern Water Conservation District
5. Dolores Water Conservancy District
6. Animas-La Plata Water Conservancy District
7. Florida Water Conservancy District
8. Northern Colorado Water Conservancy District
9. Rio Grande Water Conservation District
10. North Sterling Irrigation District
11. Central Colorado Water Conservancy District
12. Henrylyn Irrigation District
13. Mancos Water Conservancy District
14. Pine River Irrigation District

C. Municipalities

1. Denver Board of Water Commissioners
2. Pueblo
3. Colorado Springs
4. Durango
5. Alamosa
6. Westminster
7. Aurora
8. Thornton
9. Denver Metro Sewage Disposal District

D. State Agencies

1. Division of Disaster Emergency Services
2. Colorado Water Conservation Board
3. Colorado Water Resources and Power Development Authority
4. Division of Wildlife

- E. Federal Agencies
 - 1. Bureau of Reclamation
 - a. Loveland
 - b. Denver
 - c. Grand Junction
 - d. Albuquerque
 - e. Montrose
 - 2. USGS - Water Resources Division
 - a. Denver
 - b. Pueblo
 - c. Grand Junction
 - d. Meeker
 - e. Durango
 - 3. National Weather Service
 - a. Denver
 - b. Salt Lake City
 - c. Washington, D.C.
 - 4. Corps of Engineers
 - a. Omaha
 - b. Albuquerque
 - 5. Soil Conservation Service
 - 6. Colorado-Kansas Arkansas River Compact Commission
- F. Associations
 - 1. Rio Grande Water Users Association
 - 2. Urban Drainage District
 - 3. Arkansas River Rafters Association
- G. Private Entities
 - 1. Fort Lyon Canal Company
 - 2. Santa Maria Reservoir Company
 - 3. Mutual Reservoir and Irrigation Company
 - 4. Farmers Reservoir and Irrigation Company
 - 5. Colorado-Ute Electric Association

**VIII. UTILITY OF THE SATELLITE-LINKED MONITORING SYSTEM
WITHIN THE COLORADO DIVISION OF WATER RESOURCES**

NARRATIVE AND SPECIFIC APPLICATION EXAMPLES

**A. Division 1, Greeley, Colorado, South Platte River Basin
Alan Berryman, Division Engineer**

The satellite-linked monitoring system has become an integral tool in daily water rights administration in Division 1. With increasing complexity in the administration of the South Platte River basin, the system provides the key to effective decision making.

In past years, streamflow data needed for river administration was slow, if not difficult, to acquire because of the remote location of key gaging stations. Administration was inefficient and frustrating to the water commissioner and to downstream water users. With the satellite monitoring system, comprehensive river data are available to the water commissioner allowing him to administer water rights on a timely and accurate basis. This ability allows the water users to adjust more quickly to the changing conditions of the river system and expand the number of water rights able to divert and use water. The system allows the water commissioner to determine the river conditions largely on his own, not having to rely as much on data supplied by water users. This results in closer administration of water rights, potentially benefiting all water users of the area by assuring that the available supply of water is being diverted by the correct water right. Another advantage of the satellite monitoring system is that the water commissioner can release water downstream knowing that the amounts released reflect actual river conditions and won't have to be adjusted at a later date. The efficiency afforded to the water commissioner allows him to attend to more of his other duties which are ever increasing with the growth of the water rights system such as ground water administration.

With the satellite monitoring system data, the water commissioner can immediately evaluate river conditions both upstream and immediately above the senior rights. Subsequently, he can adjust diversions in his own district to satisfy the more senior rights or send a demand (call) to the upstream districts for more water to satisfy those rights early in the day. This is especially critical in administering water exchanges.

The river can be run more efficiently simply as a result of the increased knowledge of the river conditions provided by the satellite monitoring system. The readily available knowledge of river conditions also provides the water commissioner with "evidence" that can be beneficial when interacting with water users that question administrative practices. The system makes it easier for the water commissioners to interact with other district water commissioners in receiving or passing water through his district. The ability to monitor diversions by some of the major irrigation diversions including the

Burlington-Wellington Canal, the Union Ditch, the North Sterling Canal, the Lower Latham Ditch, and the Riverside Canal, is essential since the large amounts diverted can have a significant effect on the flow of the South Platte River below Denver.

Another benefit to this division resulting from the satellite monitoring system is that water from storms (flood peaks) occurring in upstream areas can be recognized early. This allows adequate time for water users to respond to these floods and divert them for beneficial use or storage rather than have the water exit the state unused. Additionally, if flood peaks larger than 2000 cfs can be diverted and reduced to 2000 cfs or less, the sand dams employed by diverters can be spared from being washed out. Preventing their washing out allows those structures to continue diverting water rather than waiting up to one week after water levels have reduced to repair the sand dams and begin diverting again. This is very important in years with low to normal flows intermingled with flood peaks from rainstorms.

The main responsibility of the Division Engineer is to coordinate the administration of water rights for the respective division. Because of the large area covered in Division 1, many tributaries and districts are administered. In order to coordinate the administration in each of the districts, knowledge of the current river conditions for the South Platte River and its tributaries is essential. Inflow from the Big Thompson River, Cache La Poudre River, and St. Vrain Creek can provide the majority of the flow in the South Platte River below Kersey. The satellite monitoring system provides the Division 1 Engineer with the basinwide information necessary to accomplish the task outlined above. In coordinating daily administration for the division, the Division Engineer can analyze conditions for the entire area early each day. With the flow information on each tributary and at various river locations, the Division Engineer can coordinate administration between districts. As an example, the information can provide the status of diversions in District 2 (Denver to Kersey) and compare that with the amount of water available in the upstream areas to decide what adjustments need to be made to Chatfield Reservoir releases in order to satisfy the senior rights below the reservoir. The information from the system can be used to monitor water releases from reservoirs to ensure that the water is reaching its proper destination. These data are incorporated directly into our flow records which previously had been worked up manually using significantly more time and resources.

As the division gets more experience in using the data and software, it is expected that additional uses will be incorporated into river administration. Included would be return flow studies, graphical analysis of flows, water quality monitoring, and development of an extensive data bank which will be invaluable as water development progresses.

The overall knowledge of river conditions made possible by the satellite monitoring system and the efficiency of administration resulting from that information have made the water commissioners and Division Engineer much more knowledgeable and responsive administrators. Once this level of performance is made possible, it is the consensus of all dealing with the system that anything less would be a major step backwards in river administration. The

utility of the system to river administrators is reflected in more responsive adjustments to river conditions, maximization of water deliveries to water users, increased knowledge of river conditions by all water users, and in time/resource savings for the administrators. Future applications will hopefully increase these benefits by adding more uses and more complete information.

COORDINATION OF ADMINISTRATION OF THE
SOUTH PLATTE RIVER IN DIVISION 1

The Division 1 Engineer administers water rights over a large geographic area that includes 12 separate administrative districts. To be effective, an up-to-date knowledge of the river conditions throughout the South Platte River basin is essential. With the flow information on each tributary and at various locations on the mainstem of the South Platte River, the Division Engineer can coordinate administration between districts. As an example, the system provides information on the status of major diversions in District 2 to compare that with the amount of water available in the upstream areas to determine what adjustments need to be made to Chatfield Reservoir releases in order to satisfy the senior rights below the reservoir. The system provides information used to monitor reservoir releases to ensure that the water is reaching its proper destination.

The hydrograph shown in the upper left plots real-time discharge data for four upper South Platte River basin stations, South Platte River at South Platte (PLASPLCO), South Platte River below Cheesman Reservoir (PLACHECO), South Platte River at Waterton (PLAWATCO), and South Platte River at Denver (PLADENCO), for June 9, 1987. The flow at PLASPLCO (upstream station) increased steadily from about 1500 cfs to 1900 cfs during the 24-hour period while the flow at PLAWATCO increased from about 1000 cfs to 2200 cfs between 0800 to 1300 hours. This indicates that an additional 800 cfs came from releases from Strontia Springs Reservoir, curtailment of diversions by Denver through the Highline Canal and Denver Pipeline, or both. Flow at PLADENCO was unsteady ranging from 1800 cfs to 4600 cfs. As the release from Chatfield Reservoir, measured at PLACHECO, amounted to approximately 1000 cfs, flow at PLADENCO was primarily the result of unsteady flow from Cherry Creek and urban runoff.

The hydrograph shown in the lower left plots real-time discharge data for four lower South Platte River basin stations, South Platte River at Henderson (PLAHENCO), South Platte River near Kersey (PLAKERCO), South Platte River near Weldona (PLAWELCO), and South Platte River at Julesburg (PLAJURCO), for June 9, 1987. The flow at PLAHENCO increased from approximately 2500 cfs to 12,500 cfs between 0000 to 0300 hours. The hydrograph shows that this water began to reach the downstream station PLAKERCO at about 1600 hours.

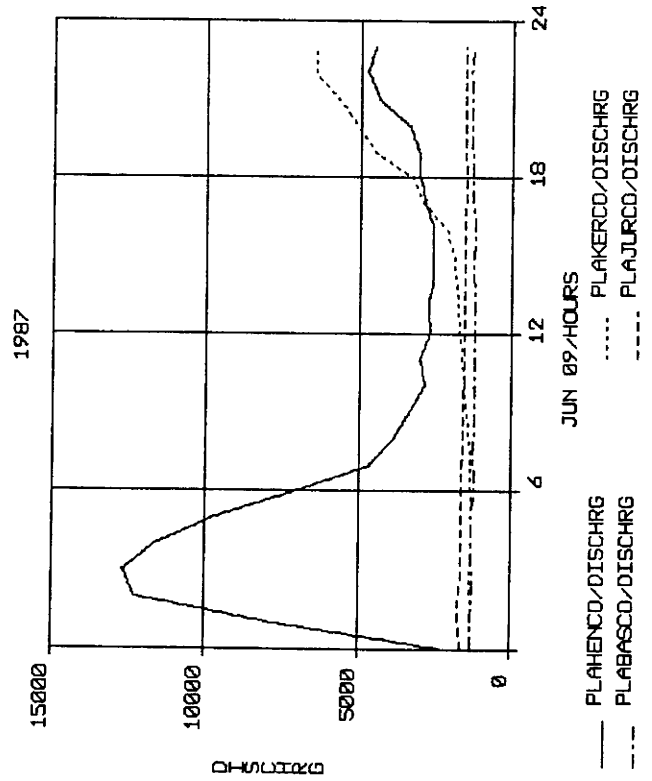
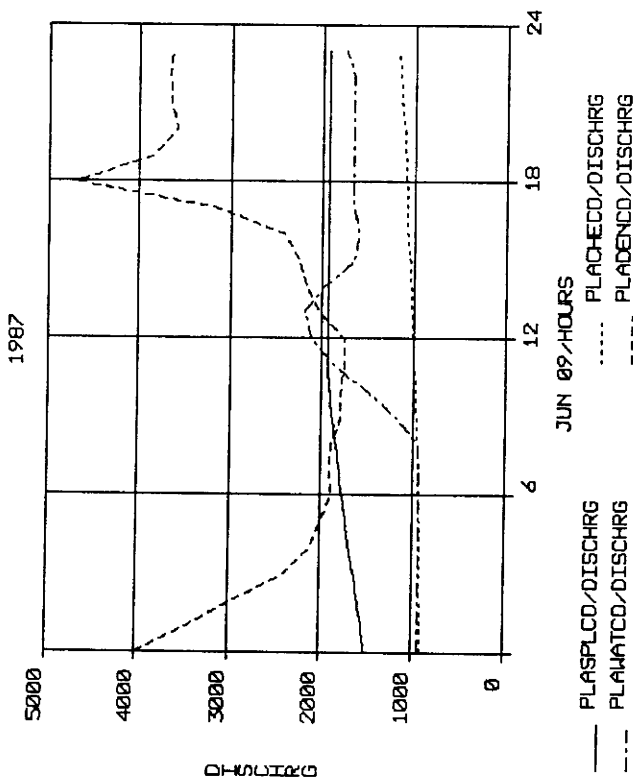

Alan Berryman, Division 1 Engineer

**ADMINISTRATION OF THE SOUTH PLATTE RIVER,
DISTRICT 2 - MONITORING TRIBUTARY INFLOW
UTILIZING REAL-TIME DATA**

The ability to monitor flow conditions of major tributaries to the South Platte River on a real-time basis is essential to effective administration of downstream water rights. Three major tributaries enter the South Platte River in the reach between Fort Lupton and Kersey (District 2). These tributaries are the St. Vrain Creek, Big Thompson River, and the Cache La Poudre River. These tributaries contribute significant flow to the South Platte River.

The hydrograph shown plots real-time discharge data for the gaging stations, St. Vrain Creek at Mouth near Platteville (SVCPLACO) and the South Platte River near Kersey (PLAKERCO) for the period June 7-12, 1987. SVCPLACO supplies approximately 20% of the flow measured at PLAKERCO. A significant hydrologic event on June 9, 1987, increased flow at both stations by over 400%.

Alan Berryman, Division 1 Engineer
Keith Delventhal, Water Commissioner, District 2

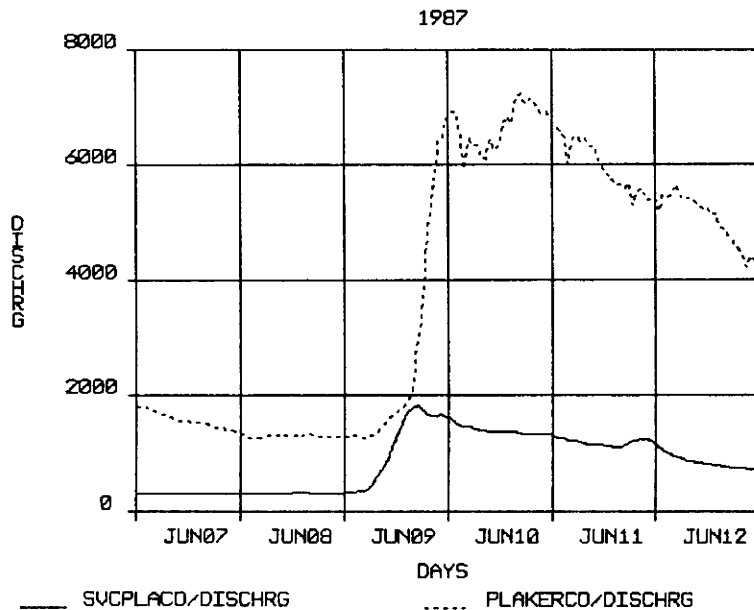

**ADMINISTRATION OF THE SOUTH PLATTE RIVER FROM KERSEY
TO THE STATELINE UTILIZING REAL-TIME DATA**

The administration of water rights in the South Platte River basin from Kersey to the stateline, Districts 1 and 64, is difficult primarily because it covers such a large geographical area. In addition, water rights in this lower reach of the South Platte River are relatively junior in comparison to upstream water rights. It is essential that these lower basin users be alerted of water availability, even short-term availability, to put all available water to beneficial use.

The hydrograph shown plots real-time discharge data for the gaging stations, South Platte River near Kersey (PLAKERCO), South Platte River at Weldona (PLAWELCO), South Platte River near Balzac (PLABASCO), and South Platte River at Julesburg (PLAJURCO), for the period August 10-14, 1987. Although flow conditions for the three upstream stations were relatively high, the flow at the stateline, measured at PLAJURCO, was relatively low and stable. The amount of water delivered to Nebraska was no more than its entitlement. This demonstrates the effectiveness of the satellite monitoring system in the hands of the Division 1 Engineer and the Water Commissioners in administering the available water resources for maximum beneficial use in the State of Colorado.

Alan Berryman, Division 1 Engineer
Robert Samples, Water Commissioner, District 1
Elton Watson, Water Commissioner, District 64

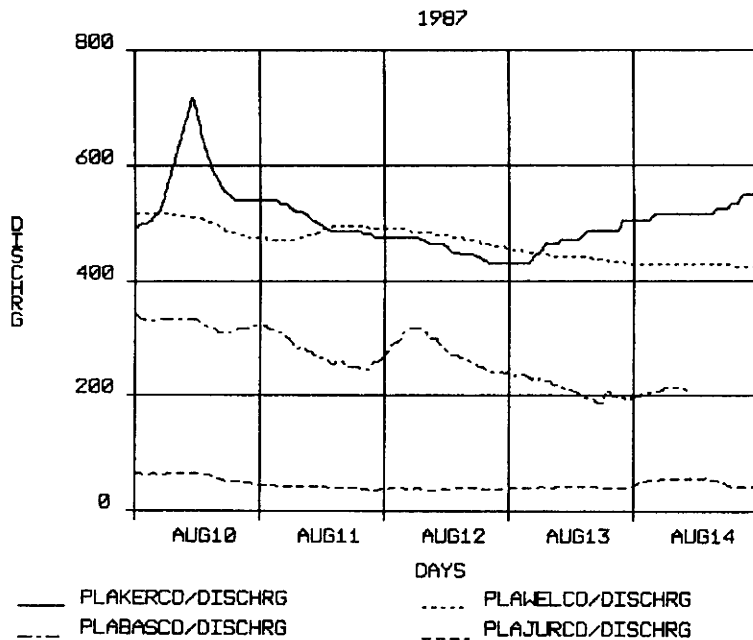

ADMINISTRATION OF THE SOUTH PLATTE RIVER,
DISTRICT 2, UTILIZING REAL-TIME DATA

In District 2, the Water Commissioner's primary responsibility is in distributing water to senior ditch rights in the reach from Henderson to Platteville. The water supply for these rights comes mainly from water passed through Chatfield Reservoir and inflows from Bear Creek, Clear Creek, and the Denver Metro Sewage outfall. The key index station for the administration of these senior rights is the gaging station, South Platte River at Henderson (PLAHENCO).

The hydrograph shown plots real-time discharge data for PLAHENCO for the period June 7-11, 1987. The most obvious characteristic of the hydrograph is the flood event occurring on June 9, 1987, as the result of a major precipitation event. Flow increased significantly from 2000 cfs to nearly 13,000 cfs in less than three hours. The water commissioner was able to alert diverters of these available flood waters for either direct diversion or for off-channel storage. Residual flood water was available for several days after. The ability to monitor these changing flow conditions on a real-time basis allows for more effective distribution of available water supplies.

Alan Berryman, Division 1 Engineer
Keith Delventhal, Water Commissioner, District 2

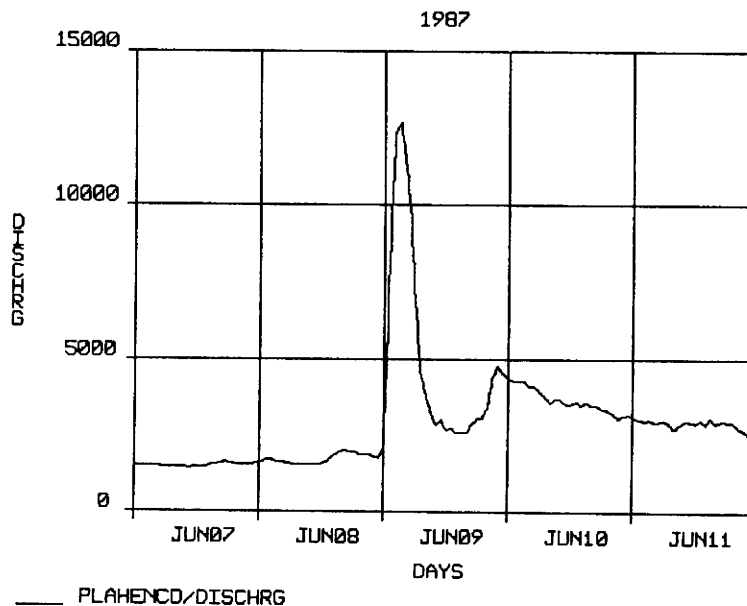

**ADMINISTRATION OF THE SOUTH PLATTE RIVER,
DISTRICT 8 - MONITORING RESERVOIR RELEASES AND MUNICIPAL
DIVERSIONS BELOW STROUTIA SPRINGS RESERVOIR AND ABOVE
CHATFIELD RESERVOIR UTILIZING REAL-TIME DATA**

The administration of water rights in Division 1, District 8, in the Upper South Platte River basin has become extremely complex due to an increasing demand for water supplies by metropolitan Denver, numerous water exchanges, and varied augmentation plans. The satellite monitoring system provides real-time data from the gaging stations, South Platte River below Strontia Springs (PLASTRCO), and South Platte River at Waterton Springs Reservoir. PLASTRCO monitors releases from Strontia field Reservoir. PLAMATCO monitors inflow into Chatfield Reservoir. Both stations are essential in reservoir regulation and in accounting. Below PLASTRCO, the Denver Water Department exercises senior water rights of up to 200 cfs by diverting flows through the Highline Canal and the Denver Pipeline. Although neither of these two diversions is monitored directly by the satellite monitoring system, diverted flows can be indirectly calculated by subtracting the streamflow being measured at PLAMATCO from the streamflow measured at PLASTRCO.

The hydrograph shown plots real-time discharge data for PLASTRCO and PLAMATCO for the period July 10-14, 1987. The table lists the mean daily discharge for both stations for each day along with the net difference in discharge between the two stations, considered to be the amount of water diverted by Denver.

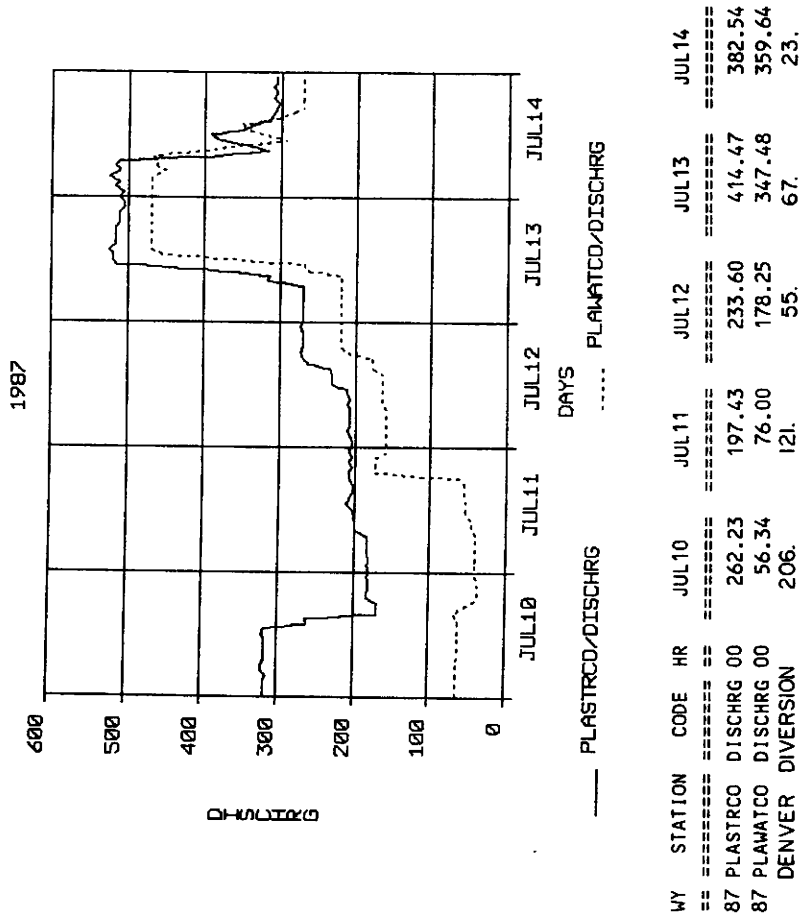

Alan Berryman, Division 1 Engineer
Kenneth Salzer, Water Commissioner, District 8

B. Division 2, Pueblo, Colorado, Arkansas River Basin
Robert Jesse, Division Engineer

The satellite monitoring system is being utilized effectively for water rights administration throughout Division 2. This includes the administration of direct diversion rights, storage rights, transmountain diversion water, the Arkansas River Winter Water Storage Program, and the Arkansas River Interstate Compact. Division 2 covers a large and diverse geographical area with a number of major senior rights. It is an arid, water thirsty area that typically dries up the Arkansas River at several locations during the late irrigation season.

Division 2 staff use the satellite monitoring system to keep an accounting of transmountain diversions that are delivered to storage, storage by exchange, and routed to ditches in the Lower Arkansas River Valley. The system has been valuable in determining daily diversions in a timely manner for accurate accounting and delivery. An example involves the exchange of Colorado Springs' transmountain diversion water discharged into Fountain Creek for storage in Turquoise Reservoir.

The capability to monitor inflows and outflows of reservoirs with accuracy in a timely manner has helped in the administration and accounting of reservoirs in the division. The routing of natural streamflow and reservoir releases to storage or through a reservoir is difficult and takes constant attention to maintain proper discharge and storage. The system also helps in keeping close watch on reservoir releases so that we can determine the section of the river the release is in and prevent any diversion of these releases except by the ditch or ditches calling for the water. The Division Engineer routinely utilizes the system to track reservoir releases from Clear Creek Reservoir, Pueblo Reservoir, and John Martin Reservoir.

We have had much success with the system in our exchange programs. It has been very valuable in determining the exact amounts of water available for exchanges. This permits maximum use of water available with no injury to other water rights.

The water commissioners in Division 2 have found the system to be an essential tool in setting the "river call". Flow conditions can vary dramatically in the period of hours rather than days due to diurnal effects of spring runoff, major tributary inflow, flash flooding from summer precipitation events, the effects of major irrigation diversions, and a high volume of imported water (transmountain diversions). The basinwide overview provided by the system on a real-time basis is a valuable tool for both short-term and long-term planning. This allows for maximum efficiency in putting Colorado water to beneficial use in Colorado. The system has been especially effective in setting the "river call" in the lower Arkansas River basin from Pueblo Reservoir to the stateline.

The system has become an integral factor in the management program of John Martin Reservoir, along with the attendant responsibilities of assuring proper deliveries to the state of Kansas and maximizing utilization of water

available to Colorado diverters. John Martin Reservoir is normally in one of two postures during the irrigation season; either storing or not storing in the conservation pool. The summer storage mode must be determined by projecting when inflow will exceed demand below the reservoir by 1,000 acre-feet per day. It then becomes necessary to monitor flows headed downriver to the reservoir, giving maximum lead time possible. The system gives the capability of monitoring upstream stations on both the Arkansas and the Purgatoire Rivers with lead times of up to 48 hours. The non-storage mode creates the situation of having to route streamflows through the reservoir body to users downstream. Monitoring of inflows is just as critical in this instance. The inflow at the stations above John Martin Reservoir plays an important part in managing winter water storage and in setting summer river calls.

During the 1987 water year, releases were made from the flood pool in John Martin Reservoir from March 24 to July 7, 1987. The Corps of Engineers determined that the safe channel capacity below the reservoir was 3,000 cfs. The monitoring system was used successfully to control releases in order to avoid exceeding channel capacity. The inflow stations above John Martin Reservoir are all incorporated into the system's monitoring network. In addition, the major irrigation diversions are in the network. Similar operating procedures were utilized for Pueblo Reservoir. This capability gives valuable lead time in order to make administrative decisions concerning streamflow routing through the reservoirs relative to standard operating procedures, which in turn affects the operation of the entire basin.

Growing concern with the quality of water as well as the quantity has created a need for data collection of parameters in addition to stream stage. The USGS has a number of stations with water quality monitors which are already in the satellite system's network. These have been interfaced with the DCPs to provide data on water temperature and total dissolved solids (TDS).

New equipment for monitoring air temperature, precipitation, snowfall, and solar radiation has been acquired to assist in improving water rights administration. Precipitation gages will give advance warning of rain peaks, snow pillows will determine snowpack, and pyranometers will provide information pertinent to calculating snowmelt.

ADMINISTRATION OF THE
ARKANSAS RIVER COMPACT UTILIZING REAL-TIME DATA

One of the most important and effective uses of the satellite monitoring system is in the administration of the Arkansas River Compact. The responsibility of assuring proper deliveries to the State of Kansas belongs to the Colorado State Engineer. Senior water rights in the reach of the Arkansas River from John Martin Reservoir to the Colorado-Kansas stateline may dry up the river at the stateline under normal conditions during the irrigation season. The bulk of the water available to Kansas is stored in John Martin Reservoir acquired during winter water storage (November 15 - March 15) or from storage during the irrigation season (March 15 - November 15) that occurs when the daily inflow to John Martin Reservoir exceeds the downstream call by 1000 acre-feet. Kansas can demand reservoir releases from their account at any time. Colorado gets credit only for water delivered at the stateline measured at the gaging station, Arkansas River near Coolidge, Kansas (ARKCOOKS). No transit loss is deducted, however, all water reaching ARKCOOKS from the initial time of arrival plus seven days after the stop of the release is credited to Colorado as a delivery to Kansas. This includes any natural flow. Colorado is credited only up to 105% of the call amount. As such, the Division 2 Engineer and the District 67 Water Commissioner strive to deliver the exact call amount, yet not under-deliver.

Kansas requested a release of 600 cfs, running for five days, beginning on July 29, 1986. The Division 2 Engineer coordinated the start of the release at 1000 hours, July 29, 1986, increasing the flow below John Martin Reservoir from 500 cfs to 1250 cfs. The additional amount released included 350 cfs out of storage for the Amity Canal. The release of this additional 350 cfs continued until August 4, 1986. The first hydrograph shown plots real-time discharge data for the gaging stations, Arkansas River below John Martin Reservoir (ARKJMRCO), Arkansas River at Granada (ARKGRACO), and ARKCOOKS, for the period July 29 to August 2, 1986. The table below this hydrograph lists mean daily discharge values for each station for that period. The 750 cfs released from storage from the reservoir beginning on July 29, 1986 and the release cutoff on August 2, 1986 are apparent on the ARKJMRCO plot. The arrival of the release at ARKGRACO approximately 24 hours later and at ARKCOOKS

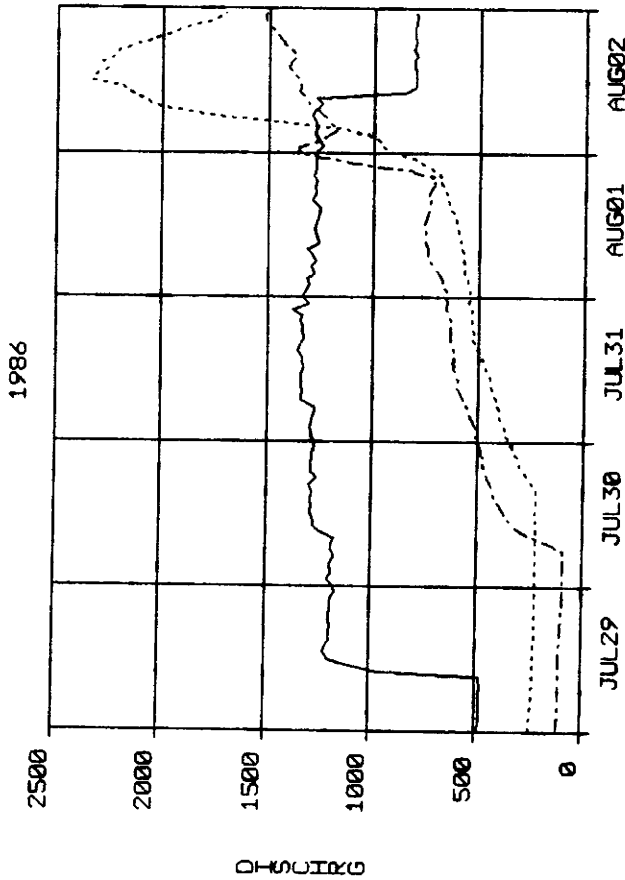

WY	STATION	CODE	HR	JUL29	JUL30	JUL31	AUG 1	AUG 2
86	ARKJMRCO	DISCHRG	00	897.63	1249.37	1325.53	1282.98	987.42
86	ARKGRACO	DISCHRG	00	106.36	314.33	600.04	773.33	1363.36
86	ARKCOOKS	DISCHRG	00	230.75	246.24	465.58	631.63	1856.61

1986
ADMINISTRATION OF THE
ARKANSAS RIVER COMPACT UTILIZING REAL-TIME DATA
(Continued)

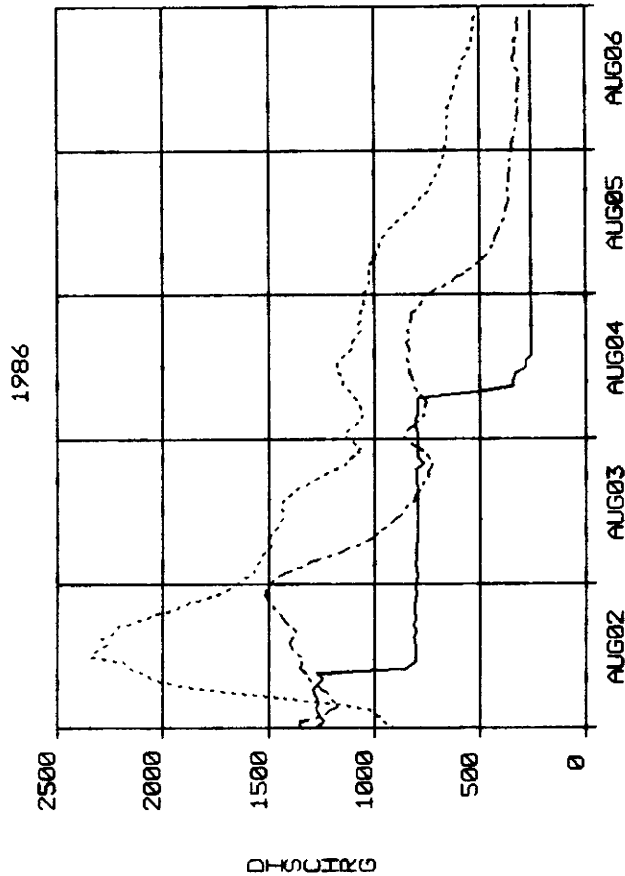

approximately 32 hours later, are apparent but subtle due to attenuation of the release front. Colorado begins to receive credit for water delivered at the time the release front is recorded at ARKCOOKS. A significant precipitation event occurring on the evening of August 1, 1986, centered on the area between ARKGRACO and ARKCOOKS, increased the flow up to 1500 cfs at ARKGRACO and up to 2300 CFS at ARKCOOKS. This prompted an early stop of the reservoir release since it was obvious from the real-time discharge data that the natural flow of the river at ARKCOOKS would continue above 600 cfs for several days. This is evidenced on the second hydrograph covering the period August 2 - August 6, 1986. Mean daily discharge values calculated for that period show that Colorado delivered the required amount of water. The satellite monitoring system saved Colorado water in this case since real-time data prompted curtailment of the release one day early.

Robert Jesse, Division 2 Engineer

--- ARKJMRCO/DISCHRG
- - - ARKGRACO/DISCHRG
..... ARKCOOKS/DISCHRG

WY	STATION	CODE	HR	AUG 2	AUG 3	AUG 4	AUG 5	AUG 6
86	ARKJMRCO	DISCHRG	00	987.42	800.09	451.23	257.00	257.00
86	ARKGRACO	DISCHRG	00	1363.36	969.30	818.09	442.90	328.25
86	ARKCOOKS	DISCHRG	00	1856.61	1387.42	1107.43	875.02	596.99

**MONITORING PEAK FLOWS ASSOCIATED
WITH PRECIPITATION EVENTS**

The Purgatoire River is a major tributary to the Arkansas River with its confluence just above John Martin Reservoir and below the upstream index station, Arkansas River at Las Animas. Flows in the Purgatoire River during the irrigation season are generally low. Flow at the gaging station, Purgatoire River near Las Animas (PURLASCO), averages less than 20 cfs for the month of July. However, due to poor natural vegetative cover, relatively impermeable clay soils, and a large drainage area of 3,503 square miles, precipitation events can result in significant yet short-term runoff events. The ability to monitor these peak flows utilizing real-time data allows for effective allocation of these flows for beneficial use downstream.

The hydrograph shown plots real-time discharge data for the gaging station, PURLASCO, for the period August 3-4, 1987. Flows on August 3, 1987 were less than 5 cfs. A precipitation event resulted in a rapid increase in discharge beginning at 2115 hours, August 3, 1987. The tabulation of hourly discharge values indicates that flow increased from 5 cfs at 2100 hours to 1670 cfs by 2130 hours. The discharge decreased steadily.

The Water Commissioners for District 17 and District 67 contacted downstream appropriators advising them of the availability of additional water supplies. The "river call" was adjusted from September 25, 1898 (in effect on August 3, 1987), to a "river call" of July 22, 1948, going into effect on August 4, 1987.

Robert Jesse, Division 2 Engineer
William Howland, Engineering Technician
Don Taylor, Water Commissioner, District 17

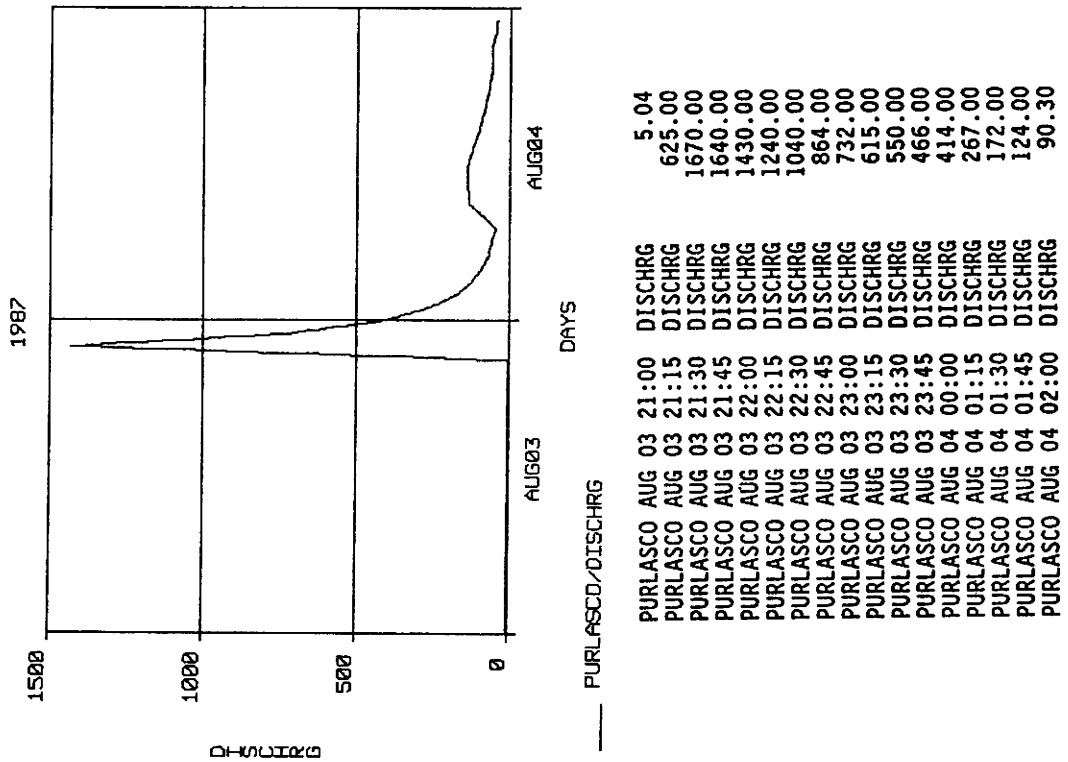

REAL-TIME ACCOUNTING OF EXCHANGES OF
TRANSMOUNTAIN DIVERSION WATER WITH UPSTREAM NATIVE FLOW

Transmountain diversion water is unique since Colorado water law allows reuse as long as dominion and control are maintained of the return flow. This system application example involves the exchange of transmountain return flows for upstream native flow.

The City of Colorado Springs releases treated municipal water (return flow originating from a transmountain diversion) into Fountain Creek which flows into the Arkansas River. As Colorado Springs has no use for the water below this point, the Division 2 Engineer has approved an exchange to take place at Turquoise Reservoir in the Upper Arkansas River basin. Colorado Springs is permitted to store an amount equivalent to the volume released into Fountain Creek minus the transit loss to the confluence with the Arkansas River. The gaging station, Fountain Creek near Pinon (FOUPINCO), located above the confluence, is utilized as the index station. The following conditions must be satisfied before the exchange can take place:

1. A call must be in effect on the Arkansas River in the reach below the confluence.
2. The daily native flow into Turquoise Reservoir, measured at the gaging station, Lake Fork Creek above Turquoise Reservoir (LKCTURCO) must be equal to or greater than the net flow measured at the gaging station FOUPINCO.

The hydrograph shown plots real-time flow data measured at the gaging stations, FOUPINCO and LKCTURCO, for the period July 8-12, 1986. Note that the flow at FOUPINCO never exceeds the flow at LKCTURCO. There was no natural flow in Fountain Creek during this period.

Listed below the hydrograph is a tabulation of system derived mean daily flows for FOUPINCO and LKCTURCO and the net native flow to be released from Turquoise Reservoir back to the river.

Robert Jesse, Division 2 Engineer
Tom Simpson, Engineering Technician

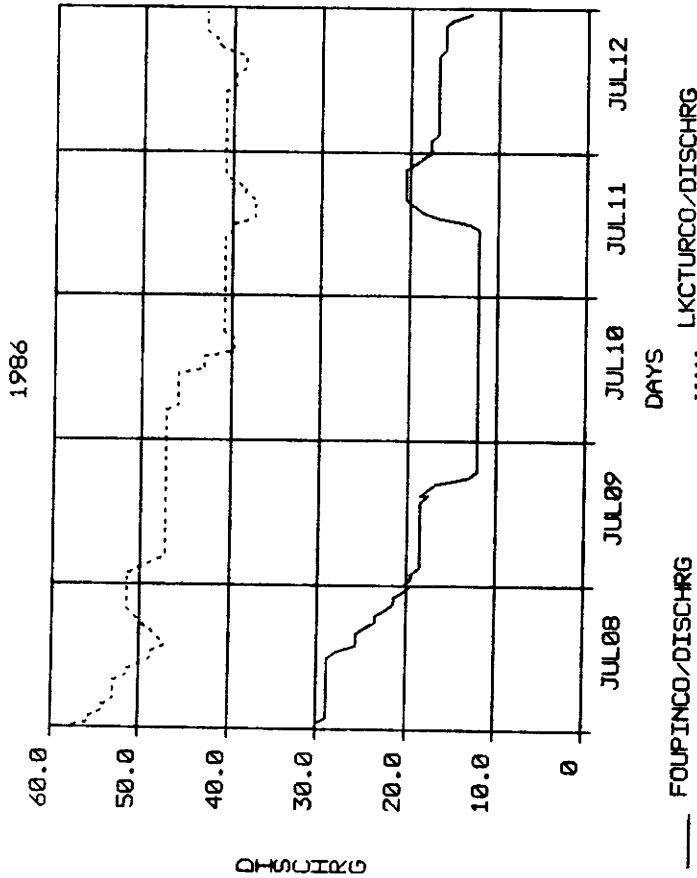

DAILY AVERAGES

WATER YEAR	STATION	DATA/TYPE	JULY 8	JULY 9	JULY 10	JULY 11	JULY 12
86	FOUPINCO	DISCHRG (cfs)	26.41	16.79	12.09	15.67	16.45
86	FOUPINCO	VOLUME (AF)	52.38	33.30	14.07	31.08	18.43
86	LKCTURCO	DISCHRG (cfs)	51.90	47.60	43.62	39.85	40.78
86	LKCTURCO	VOLUME (AF)	102.94	94.41	86.52	79.04	80.73
86	TURQUOISE RESERVOIR RELEASE	DISCHRG (cfs)	25.49	30.80	36.52	24.18	31.40
86	TURQUOISE RESERVOIR RELEASE	VOLUME (AF)	50.56	61.11	72.45	47.96	62.30

DETERMINING TRANSIT TIMES
UTILIZING REAL-TIME DATA

A knowledge of transit times is essential in advance planning relative to water rights administration and in tracking reservoir releases and transmountain diversions. The application example given involves a reservoir release of 225 cfs with a total of 3,000 acre-feet from Clear Creek Reservoir into the Arkansas River. The release was initiated on April 24, 1986.

The hydrograph shown plots real-time discharge data for two gaging stations downstream from Clear Creek Reservoir, Arkansas River near Welleville (ARKWELCO), and Arkansas River at Portland (ARKPORCO), for the period April 13-17, 1986. The arrival times of the release are apparent on both the hydrograph and the tabulation of discharge values listed at 15-minute intervals. The release arrived at the upper station, ARKWELCO, at 1600 hours, April 16, 1986. The release arrived at the lower station, ARKPORCO, at 1215 hours, April 16, 1986. The transit time is calculated to be 20.25 hours. The distance between the two stations is 71 miles.

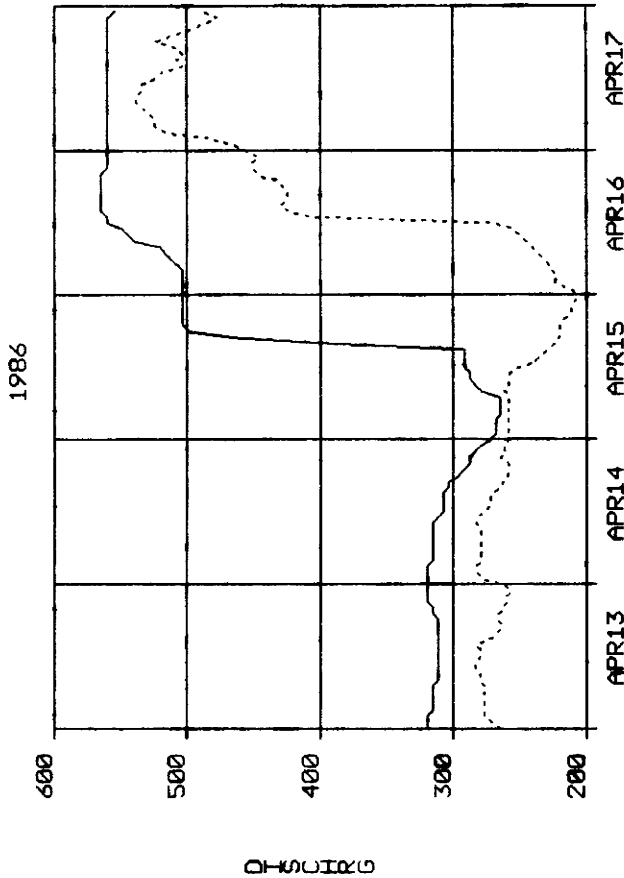

DISCHRG
 _____ ARKWELCO/DISCHRG
 ARKPORCO/DISCHRG
 DAYS

Tom Simpson, Engineering Technician, Division 2

Station	Date	Time	Discharge (cfs)
ARKWELCO	APR 15	14:00	291.00
ARKWELCO	APR 15	14:15	291.00
ARKWELCO	APR 15	14:30	291.00
ARKWELCO	APR 15	14:45	291.00
ARKWELCO	APR 15	15:00	291.00
ARKWELCO	APR 15	15:15	291.00
ARKWELCO	APR 15	15:30	291.00
ARKWELCO	APR 15	15:45	291.00
ARKWELCO	APR 15	16:00	395.00
ARKWELCO	APR 15	16:15	462.00
ARKWELCO	APR 15	16:30	462.00
ARKWELCO	APR 15	16:45	462.00
ARKWELCO	APR 15	17:00	462.00
ARKWELCO	APR 15	17:15	467.00
ARKWELCO	APR 15	17:30	467.00
ARKWELCO	APR 15	17:45	467.00
ARKWELCO	APR 15	18:00	498.00
ARKPORCO	APR 16	11:00	257.00
ARKPORCO	APR 16	11:15	260.00
ARKPORCO	APR 16	11:30	260.00
ARKPORCO	APR 16	11:45	260.00
ARKPORCO	APR 16	12:00	269.00
ARKPORCO	APR 16	12:15	300.00
ARKPORCO	APR 16	12:30	372.00
ARKPORCO	APR 16	12:45	392.00
ARKPORCO	APR 16	13:00	404.00
ARKPORCO	APR 16	13:15	408.00
ARKPORCO	APR 16	13:30	420.00
ARKPORCO	APR 16	13:45	425.00
ARKPORCO	APR 16	14:00	425.00
ARKPORCO	APR 16	14:15	425.00
ARKPORCO	APR 16	14:30	429.00
ARKPORCO	APR 16	14:45	429.00
ARKPORCO	APR 16	15:00	429.00

C. Division 3, Alamosa, Colorado, Rio Grande Basin
Steve Vandiver, Division Engineer

The satellite monitoring system, after four years of use in the Rio Grande basin in Division 3, has successfully been incorporated into daily water rights administration, water resources accounting, flood monitoring, dam safety, and in hydrologic records development.

A primary responsibility of the Division 3 Engineer is in the administration and accounting of the Rio Grande Compact. The Rio Grande Compact was written to provide for an equitable distribution of the waters of the Rio Grande between the three states of Colorado, New Mexico, and Texas. Colorado has an annual obligation to deliver water to the Colorado-New Mexico stateline based upon two delivery schedules--one for the Rio Grande and one for the Conejos River basin, a large tributary of the Rio Grande. This obligation is based on the index flows of the Rio Grande, Conejos, Los Pinos, and San Antonio Rivers. There are a total of seven compact stream gaging stations on those four river systems, all of which are equipped with the satellite monitoring hardware. The Bureau of Reclamation installed satellite-linked data collection hardware at Platoro Reservoir on the Conejos River monitoring reservoir stage elevation, precipitation, and gate openings. The data have been extremely useful during this past water year in the administration of water purchased by the Conejos River basin water users from the Bureau of Reclamation. The data collection platform installed at the Bureau of Reclamation's Closed Basin Project was activated this year, enabling the monitoring of Compact releases to the Rio Grande on a real-time basis.

The satellite monitoring system is invaluable due to the fact that these gages are widely dispersed in the San Luis Valley and the flows measured at the sites are needed daily for proper administration of both the Compact and the water rights on those streams. Prior to the satellite monitoring system, our water commissioners spent valuable administrative time driving to these gages to ascertain the flows at these gages before the water could be properly distributed. Now this information is available at any time to them from their homes and offices. Much more time can be spent on the streams and ditches ensuring that effective administration of water rights is accomplished and that New Mexico and Texas are receiving the proper amount of water and, more importantly, that Colorado water users receive all the water to which they are entitled. An example of the system's utility has been in delineating the natural flow component of the Conejos River from storage releases out of Platoro Reservoir.

The system is able to give not only real-time data, but can provide cumulative amounts of water over past periods of time. The Compact is so sensitive that 10-day updates must be done to ensure that proper amounts of deliveries are occurring. The computer software provided with the system does those evaluations saving both time and expense and provides us much more timely data on which to base our adjustments and projections.

Daily administration of water rights on the Rio Grande and its tributaries is more efficient and effective due to the system. This improvement has been to the benefit of water users in the basin. The majority of the monitoring stations in Division 3 are located on the Rio Grande and Conejos

Rivers. By accessing the computer processed data each morning, water commissioners know immediately the flow in the rivers in their areas. The runoff during this water year was well below normal making the availability of real-time flow data much more critical than in past years.

Computerized data processing of streamflow records on a real-time basis is an important element of the system. There are seven gaging stations used to monitor compliance with the Rio Grande Compact. The satellite monitoring system enables these totals to be computed on a real-time basis, and is much faster and more efficient than the conventional chart-working methods. The computer programming enables Division 3 to compute monthly totals on the first of each month. The 10-day and monthly totals are sent to various agencies which monitor the Compact such as the Corps of Engineers, Bureau of Reclamation, state of New Mexico, etc. The real-time data enables Division 3 to supply information to these agencies in a more timely manner. The use of the Records Development Program was effectively expanded to gages which are not incorporated into the satellite monitoring network.

The spring runoff periods in 1985, 1986, and 1987 had exceptionally high flow amounts and put the satellite monitoring system to a real test. The system proved to be vital in monitoring the flood levels that were occurring at various towns along the Rio Grande and Conejos Rivers. In 1988, the spring runoff was well below normal, so the system was put to use on the other end of the scale. The real-time information was critical for water rights administration over the entire San Luis Valley, and also to stay in compliance with the Rio Grande Compact. The up-to-date information from the satellite monitoring system enabled the division personnel to utilize their time checking diversion structures rather than driving to the stations to obtain flow information. Without this system, Division 3 could not have managed the low water as efficiently as it did. A new system was installed at Rio Grande Reservoir this year by the water users, and proved to be very useful in keeping the reservoir at the legal storage level.

Basic monitoring of stage elevations of reservoirs can provide information relative to dam safety. In 1984, a restriction was placed on Terrace Reservoir because of an inadequately sized spillway. The spillway capacity is insufficient to handle all of the inflow during the spring runoff. This creates a problem with enforcing the restriction level when the water cannot be released fast enough. Having real-time monitoring hardware at the reservoir has been essential in keeping the water level regulated to allow space in the reservoir for the spring runoff and keep the level within the restriction. Responses to changes in inflow can be made in a more timely manner to keep from gaining or losing too much water.

To enhance the capabilities of the satellite monitoring network in the Rio Grande basin, Division 3 has installed an air temperature sensor at the Conejos River below Platoro Reservoir gaging station, and funding has been made available for additional sensors at other key stations in the basin. This information will be useful in determining ice effects and estimating winter flows at stream gages, and in identifying snowpack melt and subsequent increases in runoff.

**THE ADMINISTRATION AND ACCOUNTING
OF THE RIO GRANDE COMPACT**

Colorado has an obligation to deliver water to the Colorado-New Mexico stateline based upon two delivery schedules, one for the Rio Grande and one for the Conejos River. During selected periods of flow, the Division 3 Engineer may have to deliver up to 18% of the Rio Grande flow and 40% of the Conejos River flow to the stateline. It is to the State of Colorado's benefit not to over-deliver or under-deliver. Knowledge of real-time conditions both upstream and at the stateline delivery point is essential for planning and operations relative to the administration of the Compact. This is extremely important for the Rio Grande basin since there are no storage structures in the middle and lower reaches.

The first hydrograph shown plots real-time discharge data for the gaging stations, Rio Grande near Del Norte (RIODELCO) and the Rio Grande near Lobatos (RIOLOBCO), for the period June 1-5, 1987. During this period, the flow at RIODELCO increased steadily from 3000 cfs to almost 6000 cfs. This represents significantly high flow conditions. Flow conditions during this period at the stateline gaging station, RIOLOBCO, averaged about 1500 cfs. This indicates that diversions below RIODELCO and above RIOLOBCO increased from 1500 cfs on June 1, 1987 to 4000 cfs on June 5, 1987. The table lists mean daily discharge values for each station for the study period. The Division 3 Engineer and the appropriate Water Commissioners through the use of the satellite monitoring system, were able to monitor the development of significantly increasing flow conditions in the upper reach of the Rio Grande and advise downstream water users of the availability of surplus water.

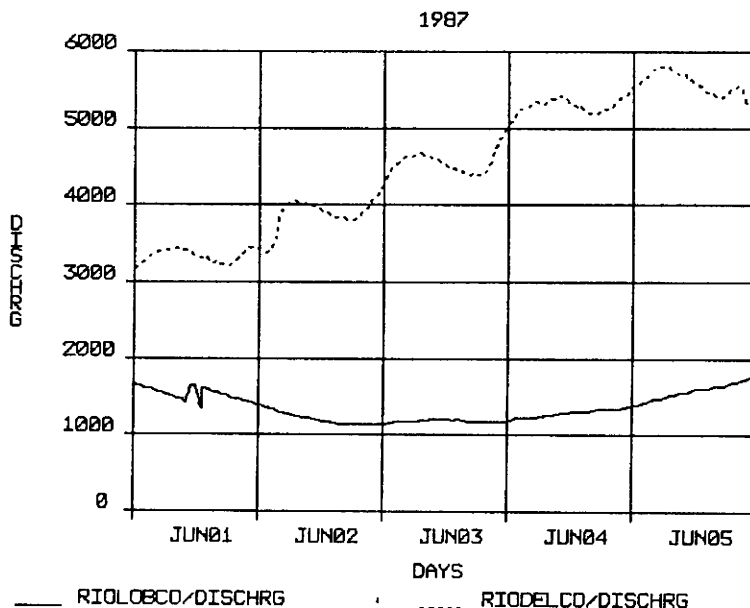

WY	STATION	CODE	HR	JUN 1	JUN 2	JUN 3	JUN 4	JUN 5
87	RIODELCO	DISCHRG	00	3344.95	3879.35	4555.74	5293.66	5562.31
87	RIOLOBCO	DISCHRG	00	1522.86	1203.24	1180.51	1288.60	1581.09

THE ADMINISTRATION AND ACCOUNTING
OF THE RIO GRANDE COMPACT
(Continued)

The second hydrograph shown plots real-time discharge data for the gaging stations, San Antonio River at Ortiz (SANORTCO), North Channel Conejos River near La Sauses (NORLASCO), Conejos River near Mogote (CONMOGCO), and Los Pinos River near Ortiz (LOSORTCO), for the period June 1-5, 1987. Significantly high flow conditions existed at CONMOGCO during this period. The runoff was effectively diverted by downstream users as indicated by the NORLASCO plot for those days. The table lists mean daily discharge values for each station for the five-day period.

Steve Vandiver, Division 3 Engineer

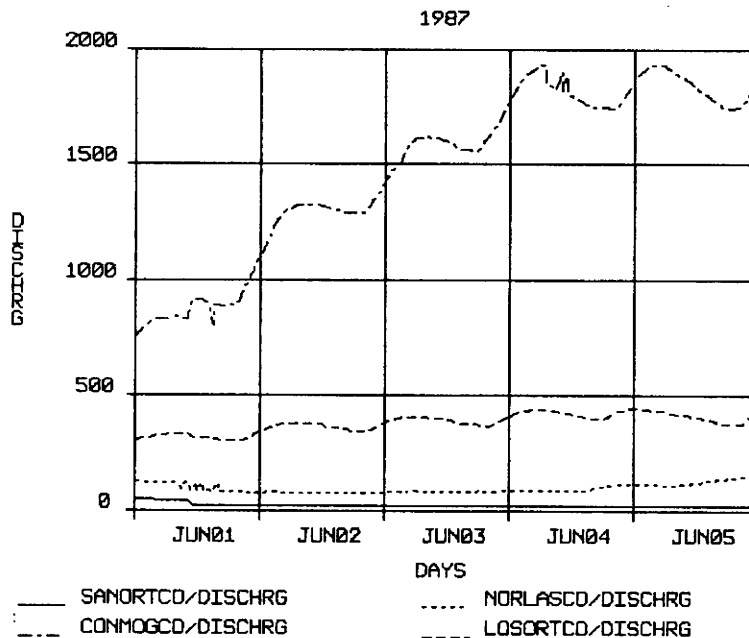

WY	STATION	CODE	HR	JUN 1	JUN 2	JUN 3	JUN 4	JUN 5
87	SANORTCO	DISCHRG	00	31.84	20.65	19.17	19.93	20.21
87	NORLASCO	DISCHRG	00	104.89	78.82	84.58	96.71	129.12
87	CONMOGCO	DISCHRG	00	879.73	1294.58	1591.70	1823.56	1840.26
87	LOSORTCO	DISCHRG	00	318.85	366.30	393.25	425.48	411.16

**ADMINISTRATION OF THE RIO GRANDE FROM THE
RIO GRANDE RESERVOIR TO ALAMOSA - DISTRICT 20,
UTILIZING REAL-TIME DATA**

The administration of this upper reach of the Rio Grande is complicated by the administration of Compact water, storage releases from Rio Grande Reservoir, no storage structures below Rio Grande Reservoir, transmountain diversion water, and water exchanges. The hydrograph shown plots real-time discharge data for the gaging stations, Rio Grande below Rio Grande Reservoir at Thirty-Mile Bridge (RIOMILCO), Rio Grande near Del Norte (RIODELCO), Rio Grande near Monte Vista (RIOMONCO), and Rio Grande at Alamosa (RIOALACO), for the period June 10-14, 1987. The releases from Rio Grande Reservoir, measured at RIOMILCO, increased from no flow on June 10, 1987, to 1500 cfs on June 14, 1987. Flow at the downstream stations remained steady indicating that the diversions above RIOMONCO were increased accordingly. Tributary inflow to the Rio Grande between RIOMILCO and RIODELCO is substantial, contributing nearly 6000 cfs during the five-day period. Between the RIODELCO and RIOALACO stations, diversions account for 2000 cfs to 2500 cfs during the five-day period. The table lists mean daily discharge values for each station over the designated period.

Steve Vandiver, Division 3 Engineer
Max Nash, Water Commissioner, District 20

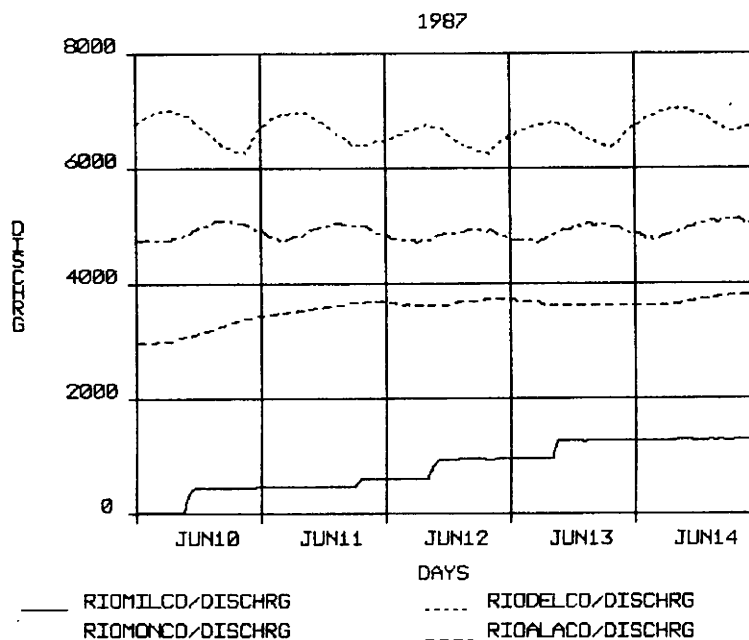

WY	STATION	CODE	HR	JUN10	JUN11	JUN12	JUN13	JUN14
87	RIOMILCO	DISCHRG	00	277.02	482.79	817.71	1161.45	1285.15
87	RIODELCO	DISCHRG	00	6707.34	6709.27	6531.41	6634.07	6872.55
WY	STATION	CODE	HR	JUN10	JUN11	JUN12	JUN13	JUN14
87	RIOMONCO	DISCHRG	00	4914.16	4925.46	4839.88	4891.16	4977.94
87	RIOALACO	DISCHRG	00	3164.65	3579.92	3661.69	3639.13	3709.45

1986
MONITORING STORAGE RELEASES FROM
PLATORO RESERVOIR UTILIZING REAL-TIME DATA

Tracking reservoir storage releases and delineating the natural flow component are essential in effective water rights administration on the Conejos River. The hydrograph shown plots real-time discharge data for the gaging stations, Conejos River below Platoro Reservoir (CONPLACO) and Conejos River near Mogote (CONMOGCO), for the period August 3-7, 1986. The release of 60 cfs began at 0900 hours, August 4, 1986, and ended at 0900 hours, August 5, 1986. The natural flow of the river was 65 cfs as evidenced by the CONPLACO data plot. The release front reached the CONMOGCO station 15 hours later. Measured discharge at both stations indicate that 5-10 cfs were lost in transit.

Steve Vandiver, Division 3 Engineer
Paul Clark, Water Commissioner, District 22

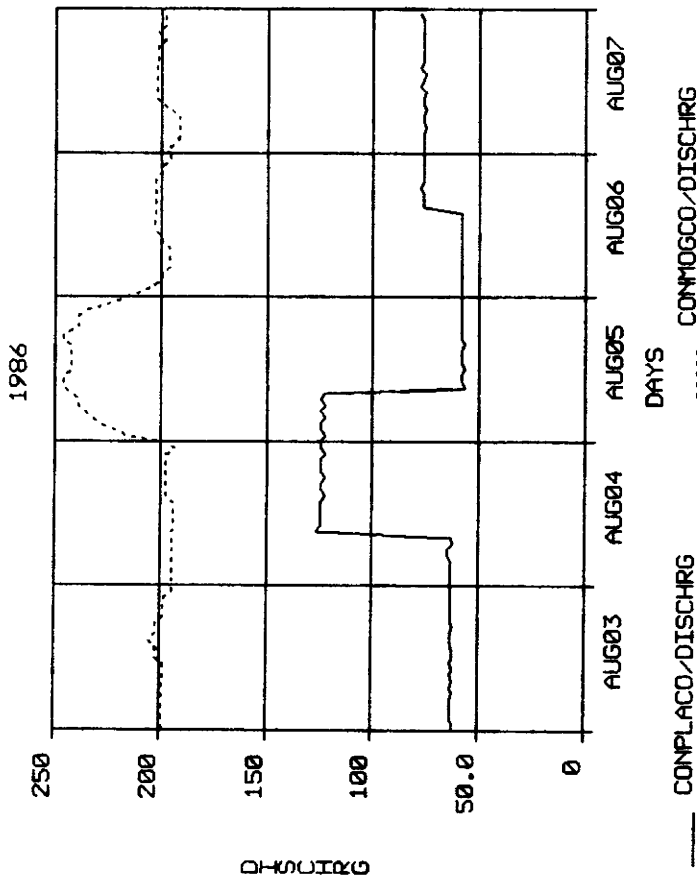

WT	STATION	CODE	HR	AUG 3	AUG 4	AUG 5	AUG 6	AUG 7
86	CONPLACO	DISCHRG	00	63.06	102.63	80.51	65.41	76.38
86	CONMOGCO	DISCHRG	00	199.66	195.49	236.56	201.00	198.28

D. Division 4, Montrose, Colorado, Gunnison River Basin
Thomas Kelly, Division Engineer

The 1988 irrigation season proved to be a challenge in water rights administration in Water Division 4. Spring snowpack through much of the Uncompahgre and Upper Gunnison basins was estimated to be 65% of average. In addition to the usual demand on the Uncompahgre River by irrigation users, the Bureau of Reclamation was seeking to fill the new Ridgway Reservoir. The satellite monitoring system was extremely useful in determining streamflows on a daily basis so that interdistrict administrative decisions could be made promptly and effectively.

The availability of real-time data is essential in evaluating both upstream and downstream streamflow conditions in the planning and implementation of water rights administration. This is critical in Division 4 where the senior water rights are generally downstream of junior water rights. An example of this is in the Surface Creek drainage basin. There are two monitoring stations on Surface Creek, one upstream of Cedaredge and one at Cedaredge. Several important diversions are located between the two gaging stations. A high percentage of the flow is generated by snowmelt runoff which demonstrates significant fluctuations. The monitoring system affords a knowledge on flows above the irrigated areas essential for planning purposes.

The satellite monitoring system has proven to be useful in delineating the natural flow at a point in a stream from flow contributed by storage releases. An example of this application is on Muddy Creek. The senior right in the district is owned by the Fire Mountain Canal holding storage rights in Paonia Reservoir. Two monitoring stations, one located above the reservoir and the other below, provide real-time data on the respective reservoir inflow and outflow. The system has allowed the water commissioners to be more effective in water rights administration to the satisfaction of water users in the basin. There have been definite savings in travel and time.

The recent completion of Ridgway Reservoir has provided for another application of the satellite monitoring system. Two monitoring stations above the reservoir on the Uncompahgre River and on Dallas Creek provide real-time data on flow into the reservoir. A monitoring station on the Uncompahgre River below the reservoir provides real-time data on outflow. The Division Engineer utilizes these data for administering the filling of the reservoir.

The satellite monitoring system has been especially effective in identifying diurnal effects of snowmelt runoff and runoff from precipitation events. The water commissioners can notify water users of changing streamflow conditions in order to divert available water supplies for beneficial use or storage. This is critical in periods of less than adequate water supply.

The system is equipped to function as a flood monitoring and warning device. The Uncompahgre River flows through Montrose, Delta, and Olathe. Fortunately this past year, the stream systems as a whole were not in an excessive flood posture; however, this potential continues to exist, and during any one of these particular circumstances, the entire system could well be worth the cost saved in one early warning of potential flooding.

**ADMINISTRATION OF SURFACE CREEK
UTILIZING REAL-TIME DATA**

The administration of Surface Creek is complicated by having to satisfy all natural flow rights, by having to account for reservoir releases on the Grand Mesa, and due to water transferred from different drainages. Surface Creek is an over-appropriated system with the majority of senior rights diverting downstream of numerous junior rights.

The availability of real-time flow data has become an essential tool in administering water rights in Surface Creek. The hydrograph shown plots real-time discharge data for the gaging stations, Surface Creek near Cedaredge (SURCEDCO) and Surface Creek at Cedaredge (SATCEDCO), for the period May 25 - May 31, 1988. Diurnal runoff peak flows were diverted into lower priority ditches while still satisfying senior downstream diverters. The system provides advance notice of peak flows and estimated downstream arrival times. Travel time and costs are reduced in not having to visit each station to take a reading.

Tom Kelly, Division 4 Engineer
Richard Drexel, Water Commissioner, District 40

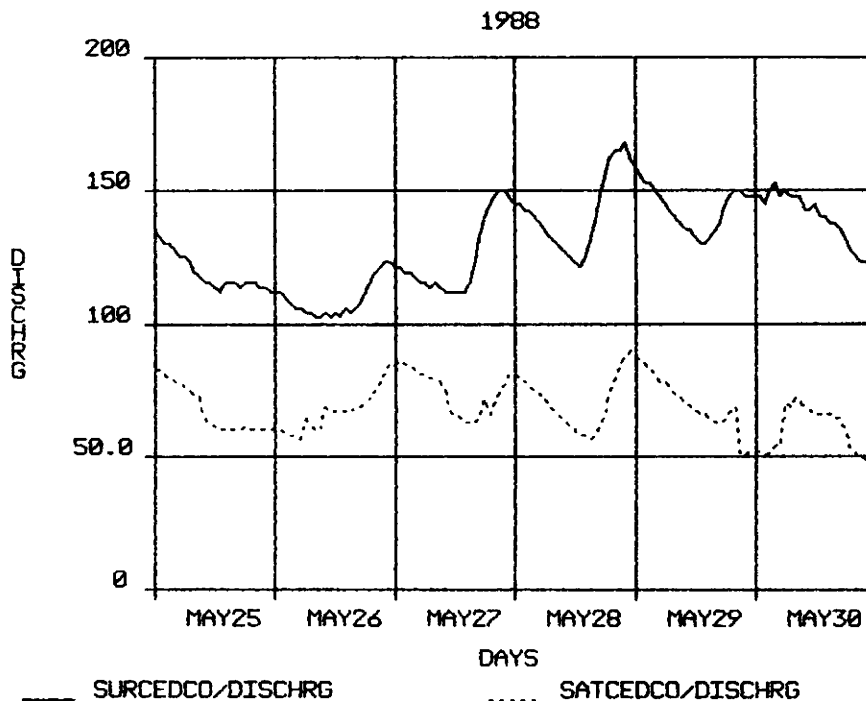

**ADMINISTRATION OF THE GUNNISON RIVER
AND THE REDLANDS CANAL
UTILIZING REAL-TIME DATA**

Flows at the Gunnison River at Grand Junction are primarily the result of flows in the Gunnison River at Delta, inflows from the Uncompaghre River at Delta, plus several points of irrigation return flows. Only minor diversions and returns exist between the gaging station, Gunnison River at Grand Junction (GUNGRJCO) and the point of diversion for the Redlands Canal (RLCGRJCO). The RLCGRJCO has a relatively senior right to divert 670 cfs from the Gunnison River for power generation and irrigation. When flow conditions dropped such that the total right could not be satisfied, the Redlands Canal Company requested that the Division Engineer place a call on the river upstream. The Division Engineer determined that the Redland Canal's right was junior to the right of the Gunnison Tunnel and as such could not call out this major diversion.

The hydrograph shown plots mean daily flow values for the gaging stations, GUNGRJCO, RLCGRJCO, and the Gunnison River at Delta (GUNDELCO), for the period July through August, 1988. The flow at GUNGRJCO dropped to less than 670 cfs for two days in late July but flows quickly increased above that amount as a result of increased return flows, rainfall, a decreased upstream water demand for irrigation, and administration of the Uncompaghre River.

Tom Kelly, Division 4 Engineer
Keith Kepler, Assistant Division 4 Engineer

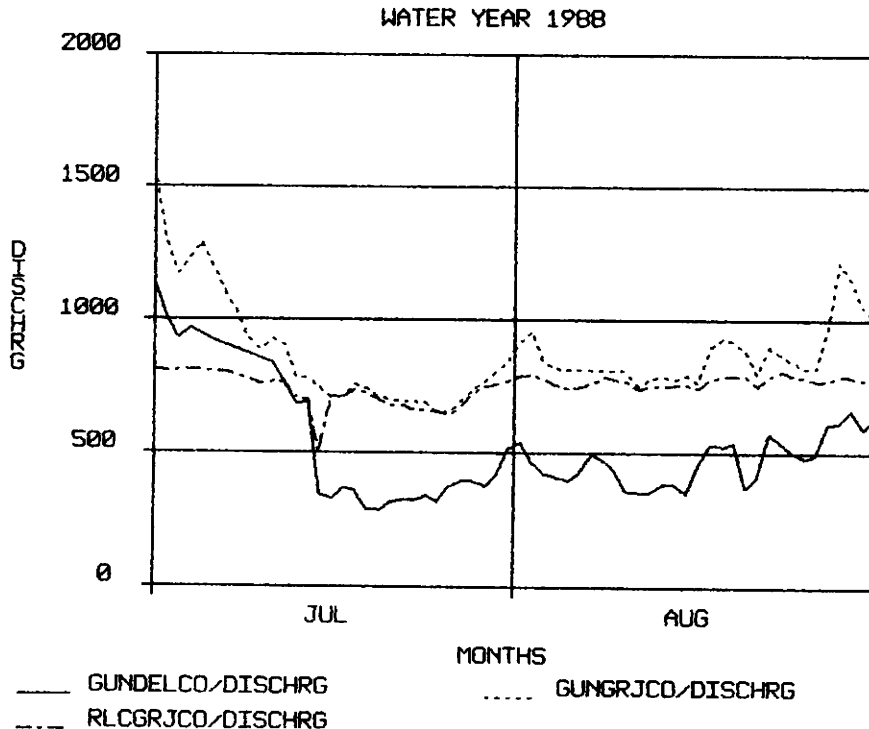

**ADMINISTRATION OF THE GUNNISON RIVER AND
BUREAU OF RECLAMATION RESERVOIRS
UTILIZING REAL-TIME DATA**

Flows in the Gunnison River are to a large extent controlled by three Bureau of Reclamation Reservoirs, Blue Mesa Reservoir, Morrow Point Reservoir, and Crystal Reservoir. Flows upstream of the reservoirs are monitored by the gaging station, Gunnison River at Gunnison (GUNGUNCO). These inflows are primarily the result of snowmelt runoff and extensive mountain meadow irrigation return flows. Releases from the reservoirs were relatively constant during the summer months at 1400 cfs. These releases exceeded the reservoir inflow during the months of July through August, 1988. The reservoirs are principally utilized for power generation. Between 1000 to 1100 cfs of the releases was diverted by the Uncompaghe Valley Water Users Association through the Gunnison Tunnel. Approximately 300 cfs was kept in the Gunnison River to flow through the Black Canyon.

The hydrograph shown plots mean daily flow values for the gaging stations, GUNGUNCO and Gunnison River below the East Portal of the Gunnison Tunnel (GUNBEPCO), for the period July through August, 1988. Flow at GUNBEPCO increased from 350 cfs to 525 cfs from August 15-20, 1988, as a result of a change in reservoir operations by the Bureau of Reclamation.

Tom Kelly, Division 4 Engineer
Keith Kepler, Assistant Division 4 Engineer

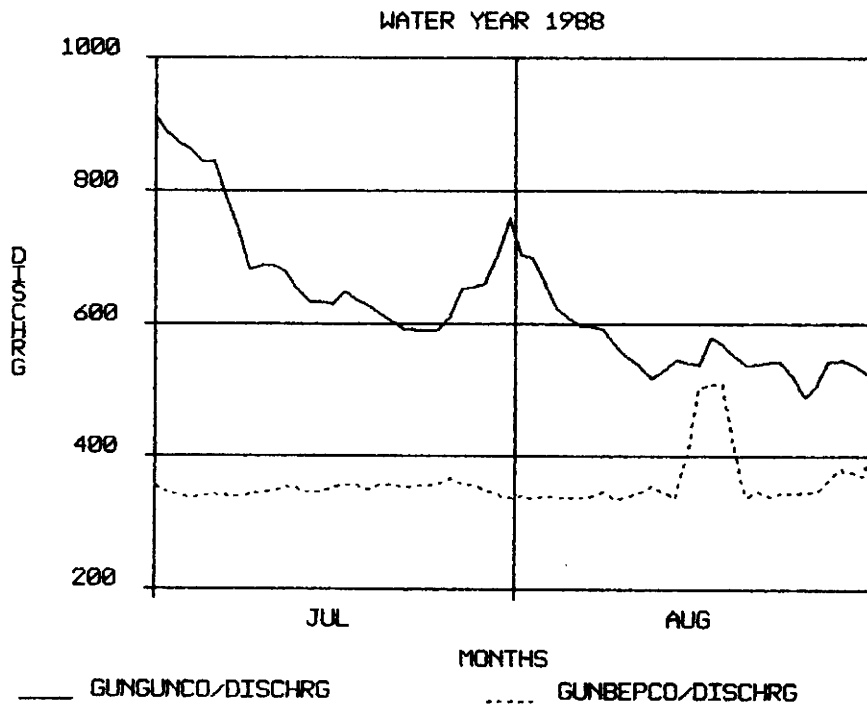

**ADMINISTERING THE OPERATION OF RIDGWAY RESERVOIR
UTILIZING REAL-TIME DATA**

The water rights for Ridgway Reservoir are relatively junior and must be closely administered so as not to injure any downstream senior rights. Two gaging stations, Uncompaghre River near Ridgway (UNCRIDCO) and Dallas Creek near Ridgway (DALRIDCO), monitor inflow to Ridgway Reservoir. The gaging station, Uncompaghre River at Colona (UNCCOLCO), monitors flow below Ridgway Reservoir. An estimate of water retained for storage in Ridgway Reservoir is computed by subtracting the flow measured at UNCCOLCO from the total flow measured at UNCRIDCO and DALRIDCO. However, analysis of actual storage levels at Ridgway Reservoir indicated that flow contributions occurring between Ridgway Reservoir and UNBCCOLCO were greater than realized. A new gaging station will be installed at the Reservoir outlet to obtain more accurate records.

The Uncompaghre Valley Water Users Association (UVWUA) controls and distributes water for nearly all of the irrigators between Colona and Delta. The UVWUA has a right to divert up to 1100 cfs from the Gunnison River below Crystal Reservoir into the Uncompaghre River. In order to meet demands on their system during the summer months, it was necessary to place a call on junior diverters upstream which limited the filling of Ridgway Reservoir. The satellite-linked monitoring system was extremely useful in providing water to junior diverters when available.

The hydrograph plots the mean daily flow for UNCRIDCO, DALRIDCO, and UNCCOLCO for the period July through August, 1988. As inflows dropped to a low of 82 cfs on July 24, 1988, it became necessary to pass all flows through Ridgway Reservoir. The result is an increase in flows at UNCCOLCO beginning on July 25, 1988, and stabilizing about 180 cfs until August 12, 1988.

Tom Kelly, Division 4 Engineer
Keith Kepler, Assistant Division 4 Engineer

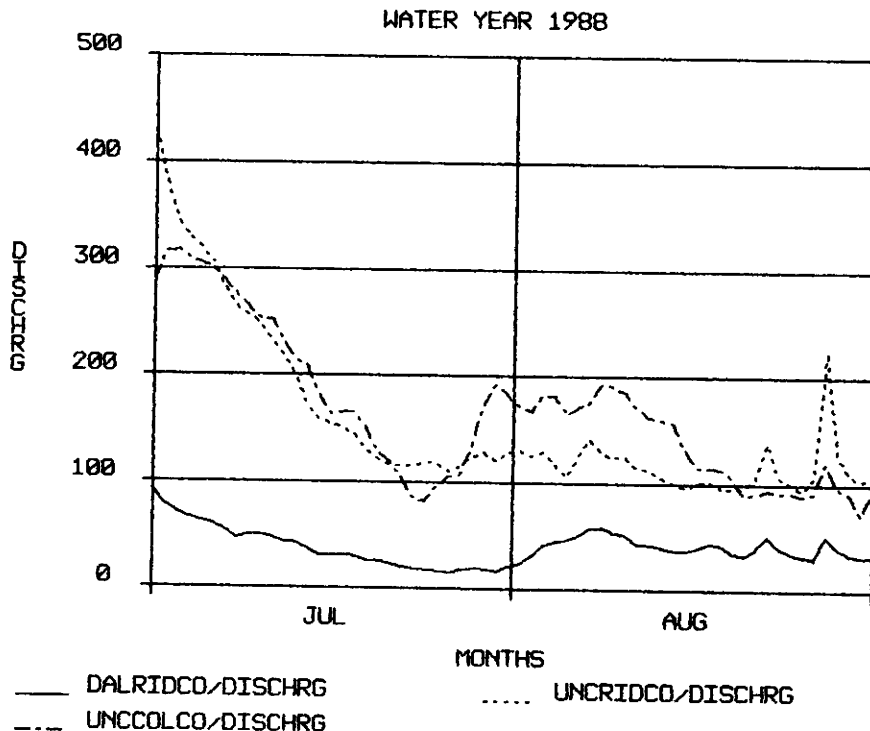

E. Division 5, Glenwood Springs, Colorado, Colorado River Basin
Orlyn Bell, Division Engineer

The utility of the satellite monitoring system in the Colorado River basin is developing at a rapid rate. As the only major river basin in Colorado that has significant amounts of unappropriated water, the system is becoming a powerful planning tool in the area of water resources development. The Colorado Front Range has several transmountain diversions from the Colorado River basin currently operating, with several others on the drawing board. The inevitable resurgence of the oil shale industry will definitely put added demand on the available supplies.

The Colorado River accounting system is a necessary tool for the administration of a mainstem call. It can determine which structures are in and/or out of priority, which owe the river, and what reservoir releases should be made for transmountain diversions, west slope depletions, and augmentation replacement. Key components of the real-time monitoring network include stations that monitor the operations of Green Mountain Reservoir and the Adams Tunnel.

The initial step in this process is the assimilation of data for direct diversions, streamflows, reservoir contents, evaporation, and precipitation. Once the data are entered into a spread sheet, needed diversion or storage adjustments can be made. Some of the data are obtained from the water commissioners on site checks and phone calls. The remainder are obtained from the satellite monitoring system. Although a small percentage of a water commissioner's structures are monitored by the system, those monitored are the majority of the ones most critical to a mainstem call, the largest, and the most likely to change from day to day. The real-time data allow us to track the river and anticipate an upward or downward trend in the river. We can reduce the lag time between a shortage or rise in flow and the corresponding adjustment to the river call. This increases the effectiveness and the efficiency of administration and saves water during critical periods.

Administration of the Blue River involves tracking a paper fill in Green Mountain Reservoir, accounting for transmountain diversions and power interference, out-of-priority replacement from a separate basin, and upstream exchanges. The Blue River shares a water commissioner with the Eagle River and, therefore, is very short-handed. Because of the lack of man-power in this area, the system is valuable not only for its real-time data, but also for the daily, monthly, and annual data stored in the archives.

**MONITORING TRANSMOUNTAIN DIVERSION FLOWS THROUGH
THE ADAMS TUNNEL UTILIZING REAL-TIME DATA**

Transmountain diversions from the Colorado River basin to the South Platte River basin as accounted for under the Green Mountain Reservoir Exchange, are monitored on a real-time basis utilizing the satellite monitoring system. Several operating points on the Colorado-Big Thompson Project are monitored by the system. This application deals with the monitoring of delivered project water at the east portal of the Adams Tunnel (ADATUNCO).

The hydrograph shown plots real-time discharge data for ADATUNCO for the period July 10-14, 1987. The daily operations of the ADATUNCO are apparent. The computed mean daily values are listed in the table.

Orlyn Bell, Division 5 Engineer
Alan Martellaro, Assistant Division 5 Engineer

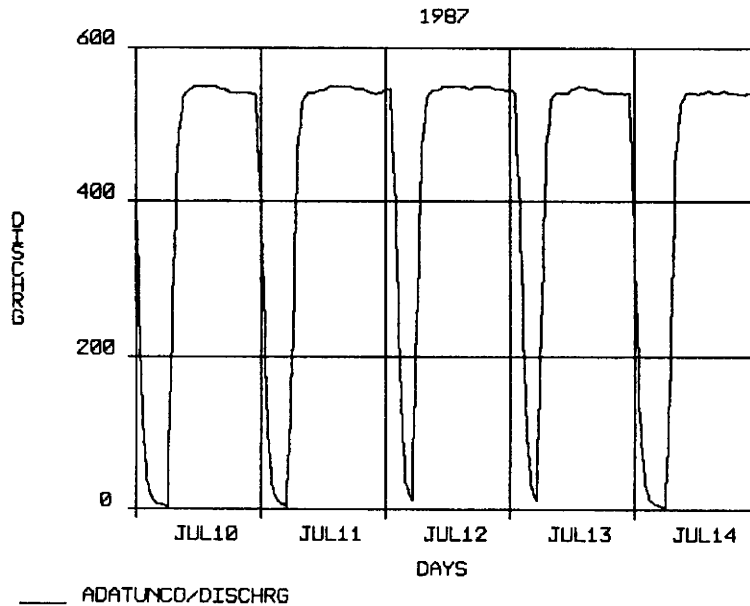

WY	STATION	CODE	HR	JUL10	JUL11	JUL12	JUL13	JUL14
87	ADATUNCO	DISCHRG	00	395.45	415.75	460.11	455.18	388.78

**MONITORING THE FLOW OF THE COLORADO RIVER
AT THE COLORADO-UTAH STATELINE**

There is considerable interest in monitoring the flow of the Colorado River at the Colorado-Utah stateline. The Colorado River Compact of 1922 in basic terms provides that 75% of the water originating in the Colorado River basin in Colorado must pass to the lower states. Colorado is not, however, putting to consumptive use all of its entitlement under the Compact.

The hydrograph shown plots mean daily discharge values for the gaging station, Colorado River near the Colorado-Utah Stateline (COLUTACO) for the 1986 and 1987 water years, which respectively ran from October 1, 1985, through September 30, 1986, and October 1, 1986, through September 30, 1987. The mean daily flow for this station for water year 1986 was greater than 11,000 cfs. The mean daily flow for this station for water year 1987 was approximately 8,000 cfs. The mean daily flow for this station for the period 1950-1981 was 5,736 cfs.

Orlyn Bell, Division 5 Engineer

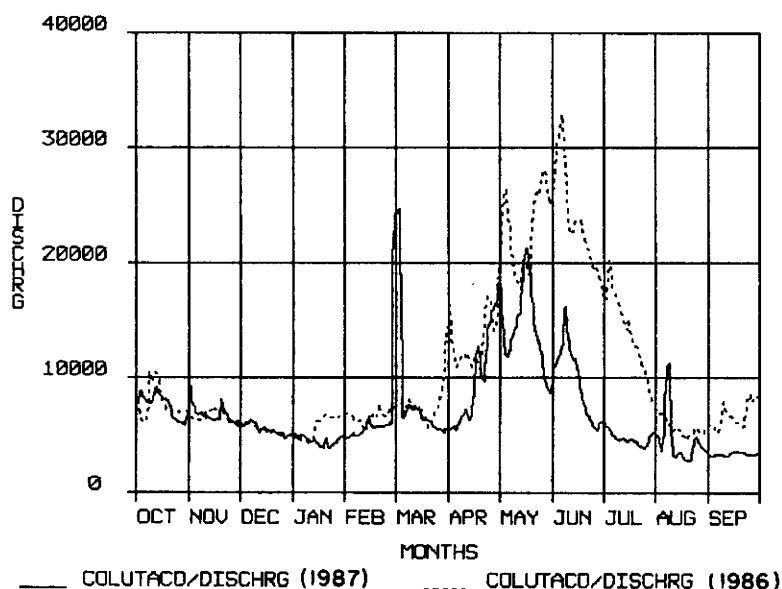

NOTE: PEAK IN LATE FEBRUARY/EARLY MARCH OF 1987 IS WATER BACKUP DUE TO ICE JAMS.

**ADMINISTRATION OF THE COLORADO RIVER
FROM KREMMLING TO CAMEO UTILIZING REAL-TIME DATA**

The 1987 water year was one of above average water supply for the Colorado River basin. However, conditions were such that a "river call" still had to be implemented for part of the year. The Glenwood Shoshone Power Plant, located in the Glenwood Canyon between Dotsero and Glenwood Springs, has a senior right amounting to 1250 cfs. This is the key water right and controls the administration of the Colorado River in this reach.

The hydrograph shown plots real-time discharge data for the gaging stations, Colorado River near Kremmling (COLKRECO), Colorado River near Dotsero (COLDOTCO), Colorado River near Cameo (COLCAMCO), and Eagle River below Gypsum (EAGGYPCO), for the period August 10-14, 1987. The discharge measured at COLDOTCO, above the Glenwood Shoshone Power Plant, ranges from 1250 cfs to 1400 cfs. The flow being contributed by the Eagle River, as measured at EAGGYPCO, did not indicate any increases. This prompted the Division 5 Engineer to place a call on the river upstream from COLDOTCO on August 12, 1987, to ensure that the senior right for the Glenwood Shoshone Power Plant would not be injured. Flow at COLCAMCO dropped to approximately 2,600 cfs but above the 2,260 cfs level that prompts a river call.

Orlyn Bell, Division 5 Engineer

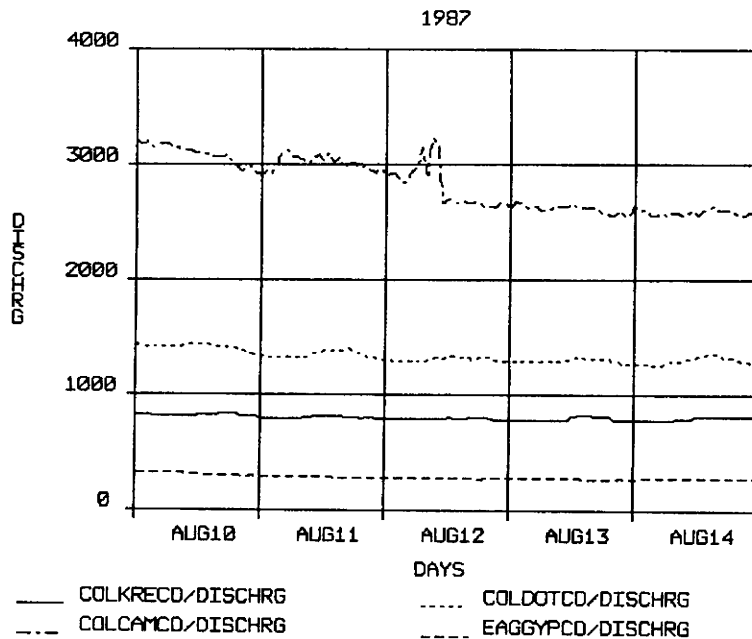

**F. Division 6, Steamboat Springs, Colorado, White/Yampa River Basin
Steven Witte, Division Engineer**

The administration of water rights in Division 6 is complicated not as much by demand as by limited manpower resources and geographic diversity. As such, the satellite monitoring system allows this office to become increasingly effective with limited staffing.

Currently, Water Districts 54, 55, and 56 are administered by a permanent part-time water commissioner who is centrally located in Craig. Although the number of water rights in this area is relatively low, access to the points-of-diversion is difficult and the distances between them is great which causes comprehensive on-site monitoring to require several man-days. Obviously, in times of administration or impending administration, this kind of delay is unacceptable to water users and could cause a breakdown of the orderly administration, regulation, and distribution of the waters of the state as required by law. For this reason, a DCP has been installed by this office on the gaging station on the upper reaches of the Little Snake River.

The gaging station, Little Snake River near Slater (LSRSLACO), is located approximately 57 miles from Craig, Colorado. The administration of the Little Snake River is governed by Article XI of the Upper Colorado River Compact which relies upon a knowledge of the flow at a point downstream of the LSRSLACO station. Historically, information from this gage has not been particularly critical, however, with the advent of Wyoming's transbasin diversion to Cheyenne in 1987, administration of the Little Snake River is a future certainty. Without access to real-time information as provided by the satellite monitoring system, it would not be possible to have the current distribution of manpower and we would have to revert to the employment of an additional permanent part-time employee which would result in an incremental cost of approximately \$2,884 per year. Although the benefits of this installation are probably not evident to the local water users at the present time, the group most likely to realize the potential advantages is the Pot Hook Conservancy District.

The gaging station, Little Snake River near Dixon, Wyoming (LSRDIXWY) is located 42 miles from Craig. USGS owned satellite-linked remote data collection hardware is installed below the largest canal on the Little Snake River. Real-time data from this station is valuable in interstate administration.

The Division 6 Engineer administers an interstate agreement between Colorado and Utah on Pot Creek. Pot Creek near Vernal, Utah (POTVERUT) is approximately 120 miles from Craig. The operation of this gaging station is included as part of a formal agreement between Colorado and Utah concerning the administration of the Pot Creek drainage. The ability to monitor compliance with this agreement remotely provides the advantages of better administration and prevents unnecessary trips saving an estimated \$780 per year.

The North Platte River and its tributaries are the most consistently administered streams in Division 6. Two water commissioners are responsible for the administration of approximately 435 structures. Historically, the

water commissioners have relied upon the efforts of volunteer gage readers who report instantaneous readings for the Michigan and Illinois Rivers on an intermittent basis in order to determine the amount of water available for distribution and to determine where efforts are most needed on any particular day. The problems with this arrangement are:

1. Volunteer gage readers are not always available when the information is most needed, i.e., weekends, holidays, at various times throughout the day.
2. The information provided is instantaneous in nature and does not indicate upward or downward trends.
3. The information gathering process is time-consuming causing delays in decision making and in responding to calls for water.

For these reasons, it was decided to establish two new stations; Illinois River near Rand (ILLRANCO), and Michigan River near Gould (MICGOUCO), by reallocating DCP's originally installed at less advantageous sites. These stations were accessed daily by the water commissioners during water administration periods. The Michigan River Water Conservancy District and the Jackson County Water Conservancy District enjoy the benefits of these two stations.

A network of four DCP's has been established to monitor the Yampa River and its tributaries from its headwaters down to Maybell, Colorado. The gaging stations, Bear River near Toponas (BEATOPCO), and Coal Creek at Mouth near Yampa (COAYAMCO), are maintained primarily for administrative efficiency. By maintaining the BEATOPCO station, which measures the inflow to Yamcolo Reservoir, and COAYAMCO, I have been able to reallocate manpower resources to allow one water commissioner to perform the same work formerly accomplished by two in this area.

The gaging station, Elk River at Clark (ELKLARCO), monitors a major tributary to the Yampa. ELKLARCO is utilized as a predictor of anticipated flows for the Lower Yampa during periods of administration.

The gaging station, Yampa River near Maybell (YAMAYCO), is a USGS owned and operated site, however, its continued operation is of vital interest to DWR for administrative purposes because of its remoteness (the water commissioner is stationed in Craig, 30 miles away) and due to its proximity to the Maybell Canal which placed the call that nearly caused the Yampa River to be administered in 1977. The Maybell Canal Irrigation District and the Juniper Water Conservancy District may be considered as indirect beneficiaries of the system.

ADMINISTRATION OF THE BEAR-YAMPA RIVER - DISTRICT 58
UTILIZING REAL-TIME DATA

The development of two storage reservoirs in the Bear-Yampa River basin brought about the need for real-time data for water rights administration. The gaging station, Bear River near Toponas (BEATOPCO), measures inflow into Yamcolo Reservoir. The gaging station, Yampa River near Oak Creek (YAMOAKCO), measures flow at the proposed Stagecoach Reservoir site.

The hydrograph shown plots real-time discharge data for BEATOPCO and YAMOAKCO for the period June 15-19, 1987. Flow at BEATOPCO, regulated by releases from Stillwater Reservoir, fluctuated between 90 cfs to 165 cfs over the 5-day period. Flow at the downstream station, YAMOAKCO, was steady at 50 cfs over the 5-day period except for a precipitation related peak on June 15, 1987.

Steve Witte, Division 6 Engineer
Truman Manes, Water Commissioner, District 58

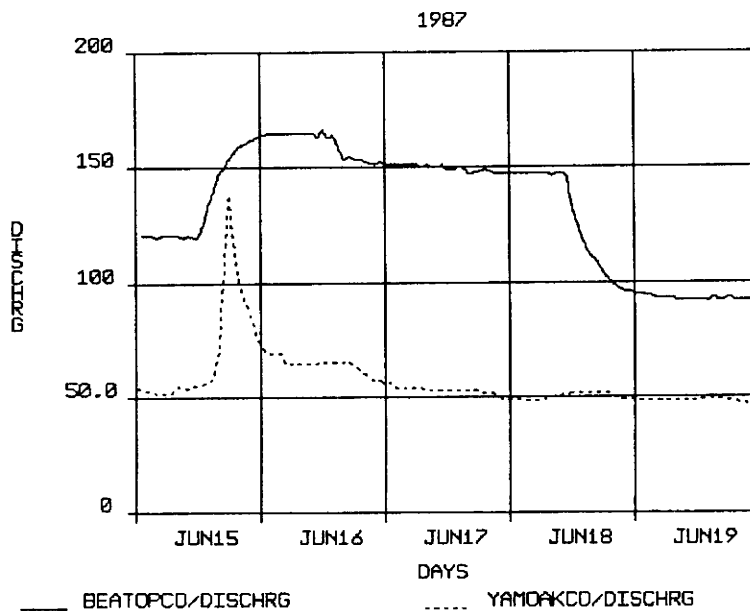

**THE ADMINISTRATION AND ACCOUNTING OF THE
COLORADO-UTAH POT CREEK INTERSTATE AGREEMENT
UTILIZING REAL-TIME DATA**

The administration of Pot Creek provides a unique example of the utility of the satellite monitoring system. Pot Creek, located in the Green River basin, flows into Colorado from Utah. An interstate agreement developed between the two states provides for Utah to receive the first 4 cfs, Colorado receives the next 6 cfs, and Utah is entitled to the excess flow. The stream runs only 4-6 weeks per year in the May-June period. The station is extremely remote, a 5-hour drive from the Division 6 office in Steamboat Springs. The gaging station, Pot Creek near Vernal, Utah (POTVERUT), measures the flow diverted by Colorado out of its account.

The hydrograph shown plots real-time discharge data for POTVERUT for the period June 1-5, 1987. The table lists mean daily discharge values for the period.

Steve Witte, Division 6 Engineer

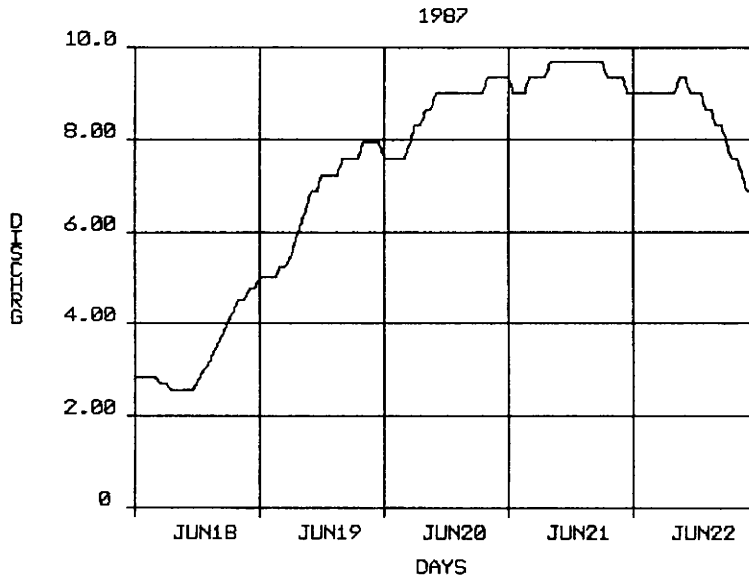

___ POTVERUT/DISCHRG

WY	STATION	CODE	HR	JUN18	JUN19	JUN20	JUN21	JUN22
87	POTVERUT	DISCHRG	00	3.34	6.70	8.68	9.46	8.50

**G. Division 7, Durango, Colorado, San Juan and Dolores River Basins
Chuck Lile, Division Engineer**

The satellite monitoring system is being effectively utilized in Division 7 for water rights administration, reservoir management, water resources accounting, and flood monitoring. The benefits of the system have reached the majority of water users in this division. Our monitoring network is unique in that the stations are located in a stream drainage which consists of separate and individual but large streams which exit the state without becoming a single administrative unit as in the other divisions.

The McPhee Reservoir and Dolores Project administration is not as yet totally functional since the project is not complete, although there are five monitoring stations in operation. The La Plata River Compact is probably our best present use and example since it is being used on a daily basis. The San Juan-Chama Project subnetwork has been effective in monitoring the Bureau of Reclamation operations, and the Lemon Reservoir subnetwork was quite helpful this past season to adjust reservoir releases.

The satellite monitoring system is being utilized for daily water rights administration relative to the Dolores Project. This includes administering allocations to the Montezuma Valley Irrigation District, Mountain Ute Indian Tribe, City of Cortez, and the Dove Creek Canal. The Division Engineer and the manager of the Dolores Water Conservancy District utilize the system in the operation of McPhee Reservoir. A water resources accounting system for the Dolores Project incorporates real-time data from five satellite monitoring stations.

The La Plata River Compact is administered on a daily basis by the Division Engineer and the District 33 water commissioner utilizing the satellite monitoring system. The water commissioner is able to access the system's data base at any time utilizing a portable computer terminal. An upstream station provides streamflow data necessary for advance planning. These conditions are typically dynamic. Early morning flows can be used to predict anticipated daily flows. Diversions are adjusted to allow for maximum daily usage yet meeting compact requirements. Dry conditions experienced in late summer and early fall required precise and prompt delivery of irrigation water to Colorado users. A station at the Colorado-New Mexico stateline gives data on actual deliveries.

Through the use of the satellite monitoring system, the water commissioner can operate the La Plata River on a real-time basis. He can observe the changes occurring at Hesperus and the stateline, and in turn, direct the diversions or curtailment of ditches in Colorado to meet the compact needs. We have found that the real-time data have greatly enhanced our ability to administer the La Plata River and are of the opinion that there has been an increase in the amount of water available to Colorado users through the prompt administration of the stream. This office has realized significant savings in travel and manpower relative to this task.

Three monitoring stations are being operated for the benefit of administering the San Juan-Chama Project and the associated interstate compact. The compact provides for the diversion of up to 1000 cfs into New Mexico. The network includes a monitoring station on the Azotea Tunnel outlet near Chama, New Mexico. The Division Engineer and the San Juan-Chama Project Manager coordinate the operation of the project utilizing real-time data. Both have access to the system's data base.

The satellite monitoring system is being utilized in the daily administration of Lemon Reservoir on the Florida River. Two monitoring stations, one above the reservoir and one below the reservoir, provide real-time data used to account for storage, delineating natural flow from storage releases, and for flood control. Diurnal inflow conditions are flattened through controlled releases.

We were able to utilize the historic data records to make tabular and graphical presentations to public groups showing effects of various water right's demands on the La Plata and Florida Rivers. These data were assembled using the Hydromet applications software.

The satellite-linked monitoring system provides a substantial benefit to a large variety of users and entities in this region. The system has not eliminated the need for public contact, physical inspections, and other duties performed by the field personnel.

**THE ADMINISTRATION OF THE COLORADO-NEW MEXICO
LA PLATA RIVER INTERSTATE COMPACT
UTILIZING REAL-TIME DATA**

Under the La Plata River Compact established in 1922, Colorado is obligated to deliver up to 100 cfs, or 50% of the flow at the Hesperus index gage, to the Colorado-New Mexico stateline on a daily basis. Decreased flow conditions prompted administration of the La Plata River system in May 1988, when New Mexico requested up to 90 cfs of its entitlement.

The hydrograph shown plots real-time discharge data for the gaging stations, La Plata River at Hesperus (LAPHESCO) and La Plata River at the Colorado-New Mexico Stateline (LAPMEXCO), for the period May 9-13, 1988. The hydrograph shows that flow increases significantly at LAPHESCO beginning on May 11, 1988. The water commissioner continuously adjusted the system to provide New Mexico with its proper entitlement but no more than that.

Chuck Lile, Division 7 Engineer
Russell Kennedy, Water Commissioner, District 33

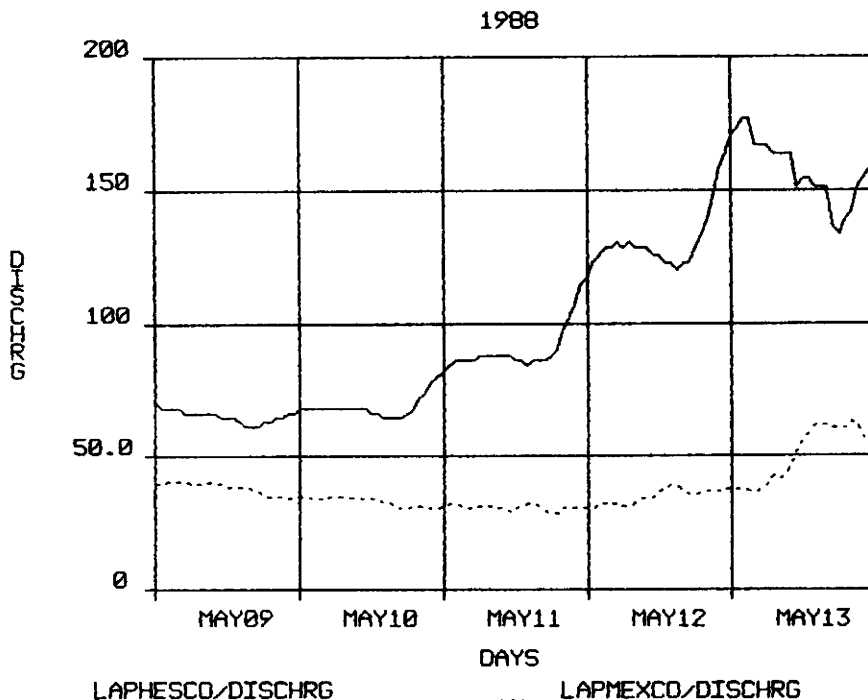

**MANAGEMENT OF
MCPHEE RESERVOIR - DOLORES PROJECT,
UTILIZING REAL-TIME DATA**

The construction of McPhee Reservoir on the Dolores River has recently been completed. The reservoir backs water over two historical diversion points of the Montezuma Valley Irrigation District (MVI District). It also intercepts several tributaries that were not available to be diverted by the M.V.I. District. Consequently, the inflow to the reservoir can, in part, belong to the M.V.I. District which has the senior priority, or to the Dolores Conservancy District that operates McPhee Reservoir and the Dolores Project. In addition to the M.V.I. District diversion through McPhee, there are water allocations for the Ute Mountain Ute Indian Tribe, City of Cortez, Montezuma Rural Water Users, and the Dove Creek Canal. In order to establish the amount of water available to the M.V.I. System, the mainstem of the Dolores River and Lost Canyon Creek are required to be measured. The outflow of the reservoir, as well as the amount delivered to the M.V.I. System and the Dove Creek Canal are also measured to insure proper delivery on a daily basis as well as a year-to-date accumulation for contractual administration. Five monitoring stations have been installed to provide real-time data essential to effective administration of project water rights and reservoir management.

The hydrograph shown plots real-time discharge data for the gaging stations, Dolores River at Dolores (DOLDOLCO), Lost Canyon Creek at Dolores (LOSDOLCO), M.V.I. Diversion (MVIDIVCO), and the Dolores Tunnel Outlet (DOLTUNCO), for the period July 1-5, 1987. Inflow into McPhee Reservoir steadily decreased from 1000 to 600 cfs with outflow remaining steady at about 375 cfs. There is no inflow from LOSDOLCO. The table lists mean daily discharge values for the period.

Chuck Lile, Division 7 Engineer
John Porter, Dolores Project Manager

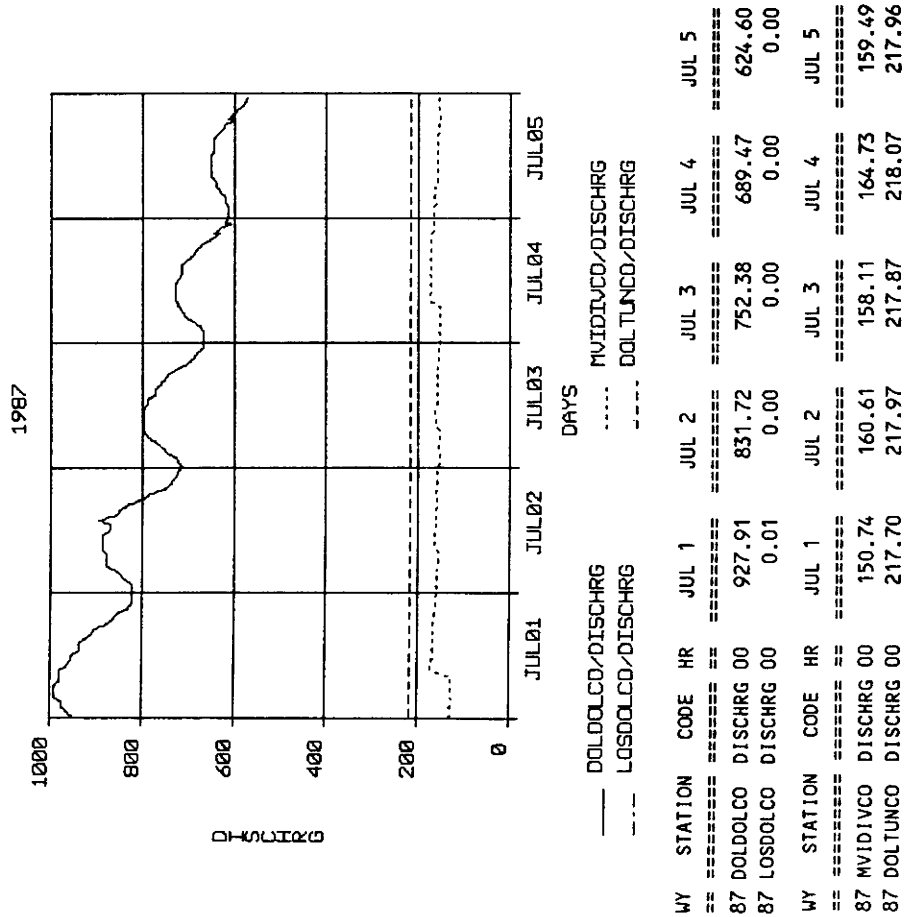

**ADMINISTRATION AND OPERATION OF LEMON RESERVOIR
UTILIZING REAL-TIME DATA**

During April, 1988, the senior right on the Florida River was experiencing water shortages. By monitoring flow conditions at the gaging station, Florida River below Lemon Reservoir (FLOBLECO), it was discovered that the operators of Lemon Reservoir were adjusting the outlet to zero flow several hours each day during this period. The operators were ordered to bring releases back to a steady state in order to properly administer the river.

The hydrograph shown plots real-time discharge data for FLOBLECO for the period April 8-14, 1988. Gate closings at the reservoir are obvious.

Chuck Lile, Division 7 Engineer
Ken Beegles, Assistant Division 7 Engineer

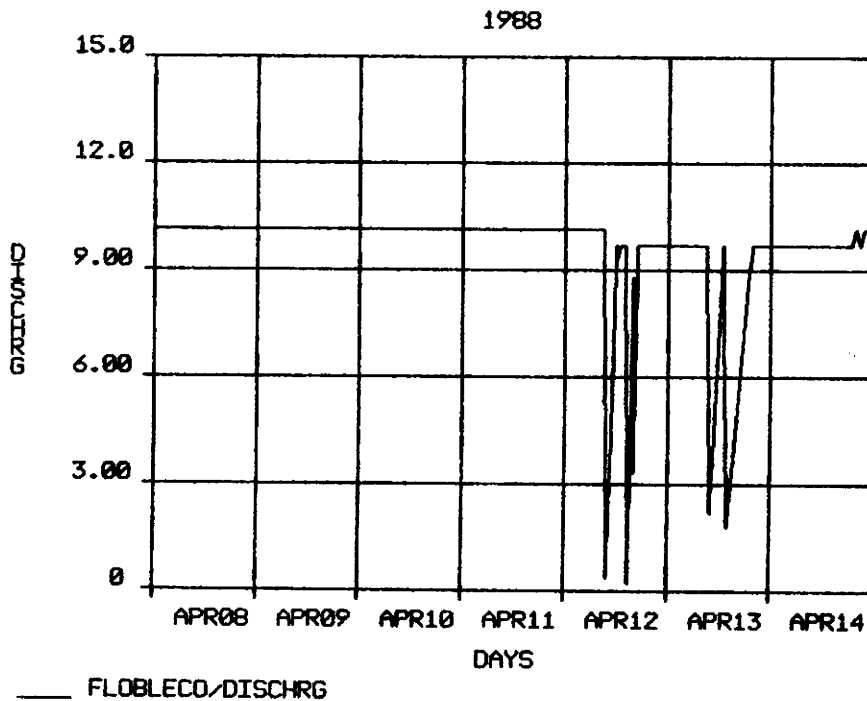

**SATELLITE-LINKED MONITORING SYSTEM PROVIDES
ANIMAS RIVER FLOW UPDATES TO AID RECREATIONISTS**

Daily hydrographs were produced using current real-time data versus flow data acquired the previous year to compare flow conditions. These hydrographs were submitted to the local paper for daily publication to aid river recreationists.

The hydrograph shown plots real-time discharge data for the gaging station, Animas River at Durango (ANIDURCO) for the period May 13-18, 1987 and 1988. The 1987 flows ranged from 3600 to 4900 cfs, while the 1988 flows ranged from 1200 cfs to 2900 cfs. Diurnal effects due to daytime snowmelt runoff are obvious.

Chuck Lile, Division 7 Engineer
Ken Beegles, Assistant Division 7 Engineer

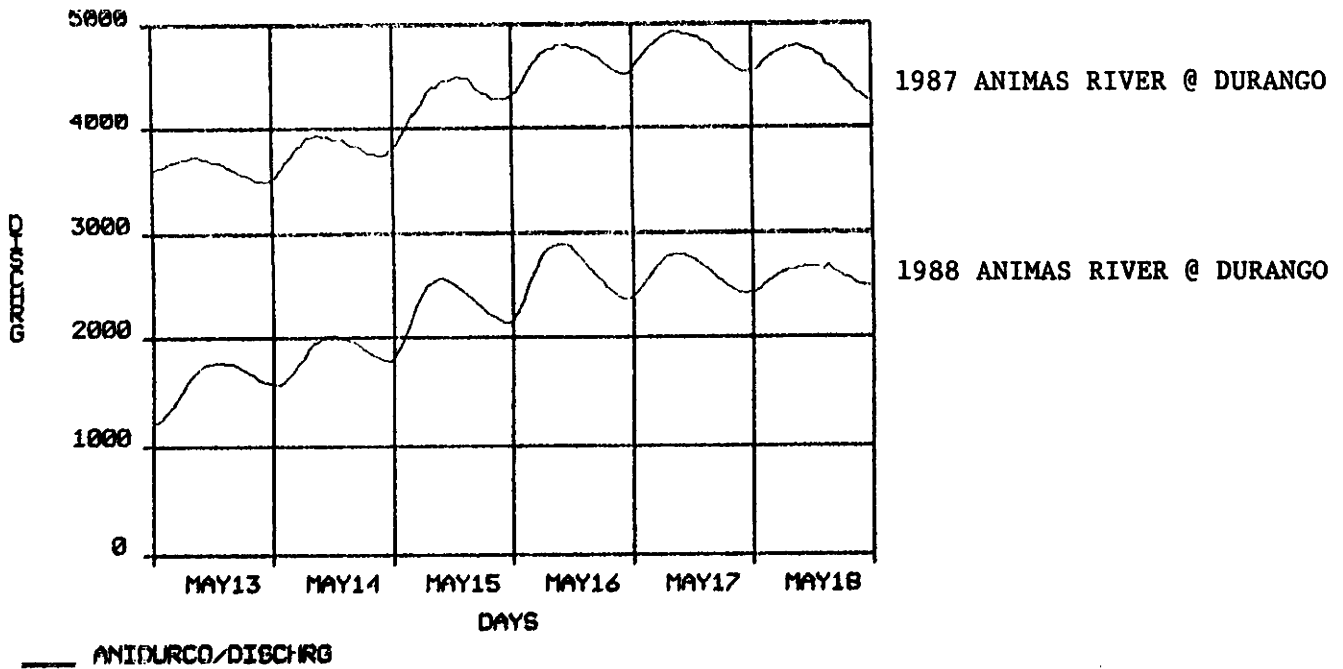

H. Flood Monitoring Utilizing Real-Time Data

The ability to obtain real-time river data through the state computer during the recent runoff season was enormously useful in aiding the National Weather Service (NWS) to satisfy the requirement put upon it by Congress to furnish flood watch and warning information to the public. There were at least three instances during the snowmelt season when a river at one of the monitoring stations reached within half a foot of the published flood stage. In two of these cases, on the Animas River at Durango and on the Cache La Poudre River near Fort Collins, the ability to monitor river levels on a continuous basis allowed the NWS to get through the peak flows without issuing spurious watches or warnings and thus unnecessarily alarming the public.

The Rio Grande in the vicinity of Alamosa reached the alarm level on June 14, 1987, triggering a computer generated call to the NWS Central Forecast Office (NWS-CFO). Since the NWS-CFO was able to monitor the river levels continuously through the system's computer, the NWS-CFO was able to ascertain that the proper course of action was to issue a flood watch, indicating that slow river rises might produce overbank flows in some areas and that persons in the vicinity should be alert. However, continual monitoring made it fairly obvious that a flood warning, indicating that serious flooding was in progress or imminent, would not be required. This again meant that alarming of the public was not necessary.

The hydrograph shown plots real-time discharge data for the gaging stations, Rio Grande near Del Norte (RIODELCO), and the Rio Grande at Alamosa (RIOALACO), for the period June 14-18, 1987. Flow at the upper station, RIODELCO, reached an alert level of 7,060 cfs at 0800 hours on June 15, 1987. Flow at the lower station, RIOALACO, reached an alert level of 3,000 cfs at 0000 hours on June 14, 1987. Evaluation of upstream conditions at RIODELCO, utilizing real-time data, indicated that on June 17, 1987, the flow was decreasing.

Larry Tunnell, Forecaster
National Weather Service
Central Forecast Office (Denver)

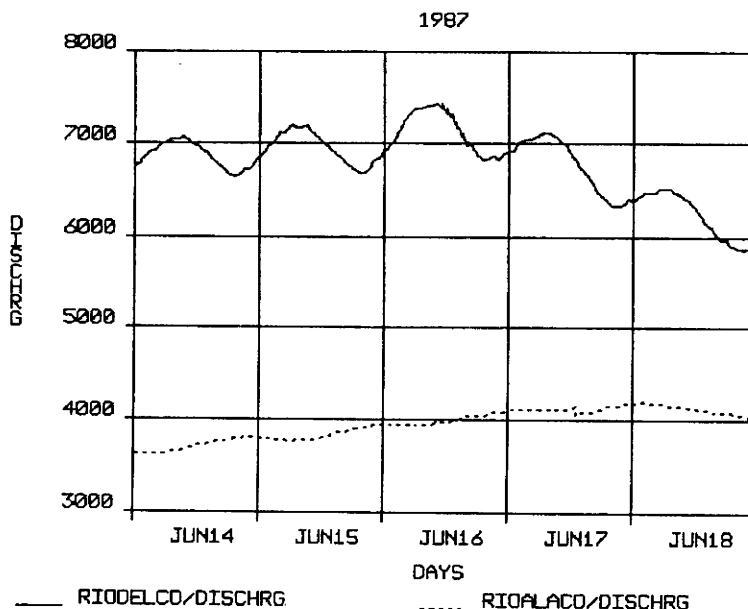

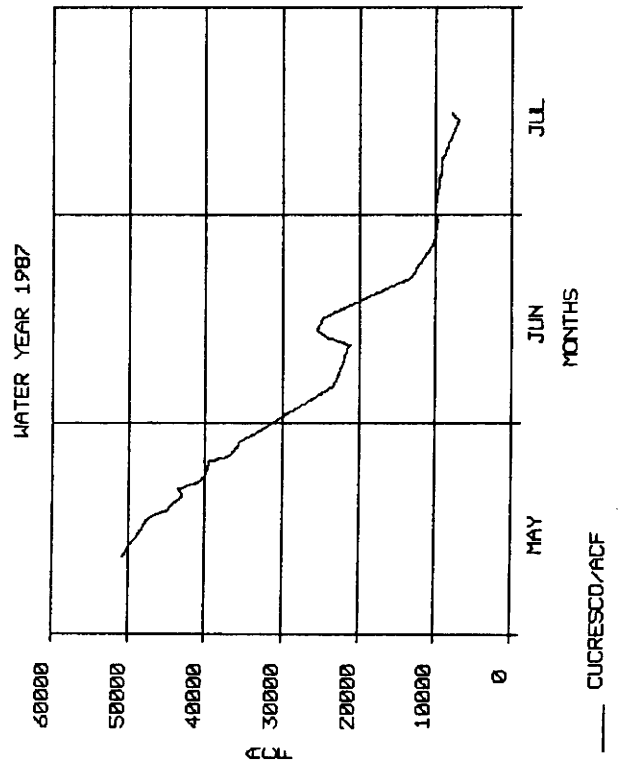
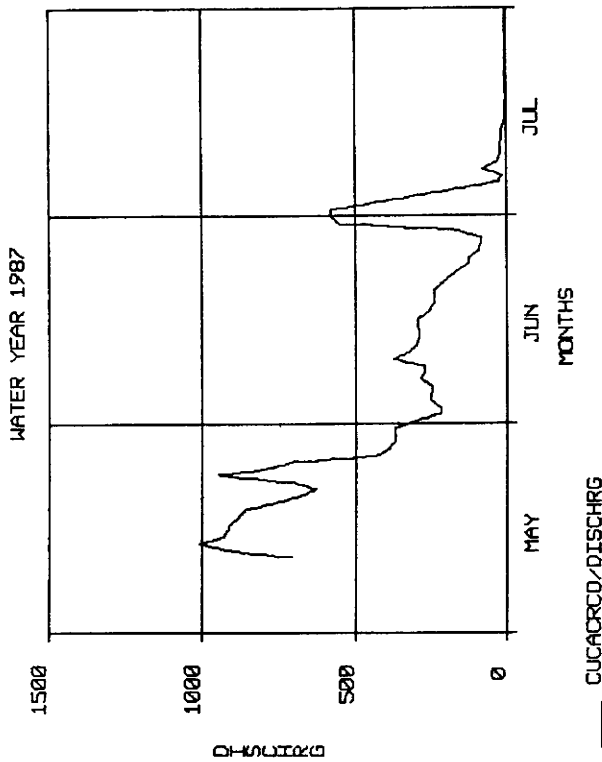

1. Dam Safety Monitoring Utilizing Real-Time Data

On May 10, 1987, the earthen dam at Cucharas Reservoir, located approximately 40 miles south of Pueblo in the Cucharas River basin, showed evidence of structural deformation. The reservoir, at near capacity of 51,000 acre-feet of water, was instrumented the next day with satellite-linked data collection hardware to monitor reservoir capacity and inflow on a real-time basis.

The reservoir outlet was capable of releasing only 500 cfs. An emergency outlet completed on May 15, 1987, provided for the release of an additional 500 cfs. The hydrograph located in the upper left hand corner plots mean daily discharge values for the gaging station, Cucharas River above Cucharas Reservoir (CUCACRCD), for the period May-July, 1987. During the month of May, inflow averaged approximately 700 cfs with peaks up to 1,000 cfs. Precipitation in late June and early July accounted for an apparent increase in runoff and subsequent inflow. The hydrograph located in the lower left hand corner plots mean daily content values for Cucharas Reservoir (CUCRESCO) for the same period. Evacuation of the reservoir was steady with an apparent slow down by late June. Reservoir capacity reached a safe level of less than 10,000 acre-feet by mid-July.

Robert Jesse, Division 2 Engineer

J. Historic Flow Data

By mid-1988, historic flow data will be archived in the satellite monitoring system data base for key gaging stations in Colorado. These data, representing mean daily discharge, will go back as far as 80 to 90 years for some stations. The data will be on-line and accessible through the HYDROMET ARCHIVES program in both report and graphics output. The availability of these historic data will be extremely valuable in making comparisons with real-time conditions. The data will be useful in determining wet-dry cycles, periods of maximum snowmelt runoff, and the effects of storage facilities on flow conditions. Periods of average, low, and high flow conditions can be identified and used to make comparisons and projections.

Historic flow data for the gaging station, Rio Grande near Lobatos (RIOLOBCO), for 1977 and 1982, were entered into the system's data base for the purpose of comparison with real-time data collected by the system for 1985, 1986, and 1987. 1977 represents a period of record low flows; 1982 represents an average flow period based on a twenty-year average; and 1985-1987 represents a record high flow period.

The Division 3 Engineer utilized these data to show Colorado water users in the Rio Grande basin that the real-time flow conditions at RIOLOBCO during May and June, 1985, were significantly high. At that time, the State of Colorado had built up a debit of approximately 800,000 acre-feet owed to the river. However, a clause in the interstate compact stated that if Elephant Butte Reservoir (located in New Mexico) ever spilled, all debits would be erased. Due to high flow conditions in 1983 and 1984, Elephant Butte Reservoir had reached near capacity. The Division 3 Engineer, utilizing the satellite monitoring system, was able to persuade the Colorado water users in the Rio Grande basin to curtail water use so as to enhance the opportunity to spill Elephant Butte Reservoir. The spill took place on June 13, 1985.

The hydrograph shown plots mean daily discharge values for RIOLOBCO for June 1977, June 1982, and for June 1985-1987. The difference in flow between June 1977 and June 1985 is dramatic. It helps to remind us that the current wet cycle that we are in can change at any time.

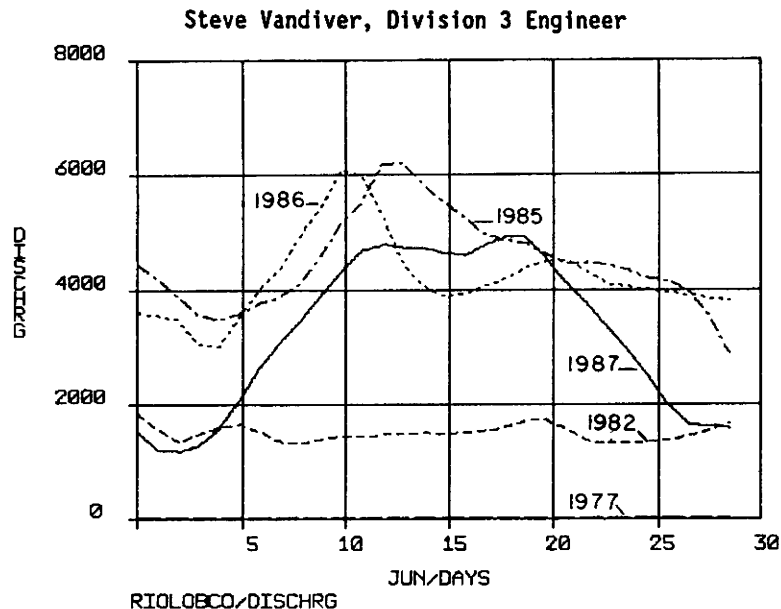

IX. DEFINITION OF TERMS

NOMENCLATURE FOR STATION NAMES

Station names have been abbreviated to eight characters. The first three characters identify the river basin, the second three characters identify the station location, the last two characters identify the state. Example: The monitoring station, Colorado River near Dotsero, Colorado, is abbreviated COLDOTCO.

DIVISIONS

The Office of the Colorado State Engineer, Division of Water Resources, is divided statutorily into seven divisions for purposes of water rights administration. The seven divisions coincide with the seven major drainage basins in Colorado. Each division has a central office administered by a Division Engineer.

Division 1, Greeley, Colorado, South Platte River Basin
Alan Berryman, Division Engineer

Division 2, Pueblo, Colorado, Arkansas River Basin
Robert Jesse, Division Engineer

Division 3, Alamosa, Colorado, Rio Grande Basin
Steven Vandiver, Division Engineer

Division 4, Montrose, Colorado, Gunnison River Basin
Thomas Kelly, Division Engineer

Division 5, Glenwood Springs, Colorado, Colorado River Basin
Orlyn Bell, Division Engineer

Division 6, Steamboat Springs, Colorado, White/Yampa River Basin
Steven Witte, Division Engineer

Division 7, Durango, Colorado, Dolores and San Juan River Basins
Daries Lile, Division Engineer

DISTRICTS

The Office of the State Engineer, Division of Water Resources, divided the state of Colorado into eighty districts for purposes of water rights administration on a smaller geographic area than a division. District administration is carried out directly by the designated water commissioner.

RIVER CALL

The "river call" refers to a date in the water rights appropriation records where water rights senior to that date may be exercised. Water rights junior to that date may not be exercised. The "river call" reflects the availability of water to satisfy those senior water rights for a district or districts. A call is placed by a water right owner when his or her right is not receiving the water to which they are entitled.

FREE RIVER

A "free river" designation exists when the availability of water exceeds the demand of active water rights.

INDEX STATION

A key gaging station that determines the availability of water for establishing the "river call" or determines the water to be delivered under a compact agreement.

FLOW AND VOLUME CONVERSIONS

Real-time discharge values, as listed in DAYFILES, are instantaneous values in cubic feet per second (cfs).

Daily discharge values, as listed in ARCHIVES, are mean values computed from 96 real-time measurements, and are in cubic feet per second (cfs).

Daily content values, as listed in ARCHIVES, are mean values computed from 96 real-time measurements, and are in acre-feet.

COMMON WATER CONVERSION FACTORS

1 cubic foot per second equals 1 cubic foot of water passing a point in one second of time.

1 acre-foot equals the quantity of water required to cover 1 acre of land 1 foot deep.

VOLUME

1 acre-foot = 325,851 gallons
1 acre foot = 43,560 cubic feet
1 cubic foot = 7.4805 gallons
1 cubic foot/second = 448.8 gallons/minute
1 cubic foot/second = 646,317 gallons/day

1 cubic foot/second = 86,400 cubic feet/day
1 cubic foot/second = 1.9835 acre-feet/day
1 cubic foot/second = 723.96 acre-feet/year
1 million gallons/day = 1.547 cubic feet/second
1 million gallons/day = 3.07 acre-feet/day

TIMES

Times given are local time based on a 24-hour clock.

APPENDIX A

**GOES-LINKED REMOTE DATA COLLECTION
HARDWARE AND ACCESSORIES**

Data Collection Platform	\$3,500 - \$4,000
Incremental Shaft Encoder	450 - 1,100
Yagi antenna	200 - 250
Antenna cable	50 - 75
12-volt power supply	50 - 175
Power supply cable	25 - 50
Environmental enclosure	200 - 300
Solar panel	250 - 350
Solar panel cable	25 - 50
Programming terminal	750 - 1,250
Grounding package	50 - 75
Float/tape/counterweight	100 - 200

Installation costs (pre-existing structure) range from \$200 - \$700.

VENDORS

Handar, Inc.
1380 Borregas Avenue
Sunnyvale, CA 94089

Telephone: (408) 734-9640

Sutron, Inc.
2190 Fox Mill Road
Herndon, VA 22071

Telephone: (703) 471-0810

Synergetics, Inc.
P. O. Box E
Boulder, CO 80306-1236

Telephone: (303) 530-2020

APPENDIX B

SENSORS THAT CAN BE UTILIZED IN GOES-LINKED REMOTE DATA COLLECTION

Water Level Measurement Sensors

Type: Shaft encoder/float
Cost: \$500 - \$1,200
Output: Analog-to-digital
Requirements: Stilling Well
Advantages: Accurate to ± 0.01 foot; easy to install and operate
Limitations: Requires a stilling well, difficult to operate with ranges greater than 10 feet; ice effected

Type: Acoustic echo-ranging
Cost: \$650 - \$850
Output: 0-5 VDC or 4-20 mA
Requirements: Stable platform installation
Advantages: Non-contact sensor; not effected by water conditions
Limitations: Accuracy $\pm 0.05\%$ of range; range 2-14 feet

Type: Pressure transducer (strain gauge)
Cost: \$700 - \$1,500
Output: 0-5 VDC or 4-20 mA; can be converted to BCD to allow for analog-to-digital output
Requirements: Stable sensor position
Advantages: No stilling well required; easy to install and operate; wide range available; portable; can position sensor at considerable distance from transmitter
Limitations: Accuracy $\pm 0.1\%$ of range; power consumption 175 mA from 12 VDC

Precipitation Measurement Sensors

Type: Tipping bucket
Cost: \$500 - \$700
Output: Analog incremental counter
Requirements: Unimpeded rain catchment
Advantages: Easy to install and operate
Limitations: Liquid precipitation only

Type: Weighing bucket
Cost: \$1,600 - \$2,200
Output: 0-5 VDC or 4-20 mA
Requirements: Unimpeded rain catchment
Advantages: Both liquid and frozen precipitation
Limitations: Scheduled maintenance necessary; measures cumulative precipitation minus evaporation

APPENDIX B (cont.)

Water Quality Sensors

Type: Multipurpose including water temperature, conductivity, pH, redox, and dissolved oxygen
Cost: \$4,500 - \$5,000
Output: Digital
Requirements: Proper site selection and data analyses
Advantages: Portable, multipurpose unit
Limitations: Scheduled maintenance necessary

Temperature Measurement Sensors

Type: Air
Cost: \$200 - \$300
Output: 0-5 VDC or 4-20 mA
Requirements: Shield from solar radiation effects
Advantages: Easy to install and operate
Limitations: None

Type: Water
Cost: \$200 - \$300
Output: 0-5 VDC or 4-20 mA
Requirements: Stable position in water
Advantages: Easy to install and operate
Limitations: Water temperature varies with depth

Snow Depth Measurement Sensors

Type: Snow pillow
Cost: \$1,500 - \$2,000
Output: 0-5 VDC or 4-20 mA
Requirements: Controlled snowcourse
Advantages: Delineates current snowpack water equivalence
Limitations: Installation must be protected from rodents