

Home Supply Ditch Co.

# DAM SAFETY MANUAL



*State Engineer's Office  
State of Colorado  
June 1983*

RICHARD D. LAMM  
Governor

JERIS A. DANIELSON  
State Engineer

a13

# **STATE OF COLORADO DAM SAFETY MANUAL**

## **AUTHORS**

**John Schurer  
Eric Wilkinson  
James Norfleet  
John Van Sciver  
Clint Huntington  
Chin Lee  
Allan Rogers**

**MEMBERS OF THE COLORADO DIVISION OF WATER RESOURCES**

**THIS PUBLICATION CAN NOT BE  
REPRODUCED UNLESS PERMISSION  
IS GRANTED BY THE  
STATE ENGINEER**

**PRICE \$8.00**

# **CONTENTS OUTLINE**

- CHAPTER 1 Introduction**
- 2 Physical Principles**
- 3 Fundamentals Of A Dam**
- 4 Visual Inspection**
- 5 Seepage**
- 6 Upstream Slope**
- 7 Crest**
- 8 Downstream Slope**
- 9 Outlet System**
- 10 Spillways**
- 11 Concrete Dams**
- 12 Monitoring And Instrumentation**
- 13 Maintenance**
- 14 Standard Operating Procedure**
- 15 Emergency Plan**
- 16 Colorado Laws**

# OUTLINE

## CHAPTER 1 — INTRODUCTION

- 1.1 Intent of This Manual
- 1.2 Definition of a Dam
- 1.3 Minimum Expected Effort
- 1.4 Critical Conditions
- 1.5 Life Expectancy of a Dam
- 1.6 Need for Stored Water
- 1.7 Role of the Dam Owner
- 1.8 Dam Safety Role of the State Engineer
- 1.9 Role of the Consulting Engineer
- 1.10 Summary

## CHAPTER 2 — PHYSICAL PRINCIPLES

- 2.1 Introduction
- 2.2 Soils for Construction
- 2.3 Particle Size
- 2.4 Soil Structure
- 2.5 Compaction
- 2.6 Moisture Control
- 2.7 Comparison of Pathways Available for the Flow of Water Through a Given Material
- 2.8 Water Pressure
- 2.9 Flow Path
- 2.10 Lengthening the Flow Path
- 2.11 Summary

## CHAPTER 3 — FUNDAMENTALS OF A DAM

- 3.1 Introduction
- 3.2 Functions of a Dam
- 3.3 Review
- 3.4 Earth Dams
- 3.5 Rockfill Dams
- 3.6 Concrete Dams
- 3.7 Spillways
- 3.8 Outlet Systems
- 3.9 Summary

## CHAPTER 4 — VISUAL INSPECTION

- 4.1 What and Why so Important
- 4.2 Inspection Equipment and its Use
- 4.3 Inspection Observations That Must Be Recorded
- 4.4 Sighting Technique
- 4.5 Some Typical Problems
- 4.6 Inspection Procedure
- 4.7 Record Keeping
- 4.8 Evaluation of Inspection Observations
- 4.9 Suggested Planning
- 4.10 Crucial Inspection Times
- 4.11 Additional Considerations
- 4.12 Summary
- 4.13 Inspection Report Form

## CHAPTER 5 — SEEPAGE

- 5.1 Introduction
- 5.2 Items of Particular Concern
- 5.3 Special Inspection Techniques
- 5.4 Field Conditions Encountered
- 5.5 Summary

## CHAPTER 6 — UPSTREAM SLOPE

- 6.1 Introduction
- 6.2 Items of Particular Concern
- 6.3 Special Inspection Techniques
- 6.4 Typical Materials
- 6.5 Field Conditions Encountered
- 6.6 Summary

## CHAPTER 7 — CREST

- 7.1 Introduction
- 7.2 Typical Materials
- 7.3 Items of Particular Concern
- 7.4 Special Inspection Techniques
- 7.5 Problem Conditions Found on the Crest
- 7.6 Summary

## CHAPTER 8 — DOWNSTREAM SLOPE

- 8.1 Introduction
- 8.2 Items of Particular Concern
- 8.3 Special Inspection Techniques
- 8.4 Typical Materials
- 8.5 Problems Found in the Field
- 8.6 Summary

## CHAPTER 9 — OUTLET SYSTEM

- 9.1 Introduction
- 9.2 Typical Outlet Configurations
- 9.3 Important Principles
- 9.4 Items of Particular Concern
- 9.5 Special Inspection Techniques and Requirements
- 9.6 Typical Materials
- 9.7 Types of Outlet Valves
- 9.8 Field Conditions to Look For
- 9.9 Summary

## CHAPTER 10 — SPILLWAYS

- 10.1 Introduction
- 10.2 Important Problems
- 10.3 Commonly Used Materials
- 10.4 Procedure for Inspection
- 10.5 Commonly Encountered Problems and Actions Required
- 10.6 Summary

- CHAPTER 11 — CONCRETE DAMS
  - 11.1 Introduction
  - 11.2 Items of Particular Concern
  - 11.3 Special Inspection Techniques and Requirements
  - 11.4 Other Conditions to Look For
  - 11.5 Summary

- CHAPTER 12 — MONITORING AND INSTRUMENTATION
  - 12.1 Introduction
  - 12.2 Factors That Cause Change In Condition
  - 12.3 Careful Monitoring Can Prevent Costly Problems
  - 12.4 Monitoring Leakage
  - 12.5 Monitoring Displacements
  - 12.6 Specialized Instrumentation
  - 12.7 Summary

- CHAPTER 13 — MAINTENANCE
  - 13.1 Tree, Brush, and Weed Control
  - 13.2 Earthwork
  - 13.3 Rodent Control
  - 13.4 Concrete Structures
  - 13.5 Steel Structures and Metal Components
  - 13.6 Outlet Gates — Mechanical Maintenance
  - 13.7 Electrical
  - 13.8 Hydraulic System

- CHAPTER 14 — STANDARD OPERATING PROCEDURE
  - 14.1 Introduction
  - 14.2 Putting the Procedure Together
  - 14.3 Assigning Responsibility
  - 14.4 Summary

- CHAPTER 15 — EMERGENCY PLAN
  - 15.1 Introduction
  - 15.2 General Information
  - 15.3 Reporting Incidents
  - 15.4 Potential Problems and Immediate Defensive Actions
  - 15.5 Helpful Suggestions
  - 15.6 Additional Considerations
  - 15.7 Sample Forms

- CHAPTER 16 — COLORADO LAWS
  - 16.1 Introduction
  - 16.2 Approval of Plans
  - 16.3 Consulting Engineers
  - 16.4 Safety Evaluation of Existing Dams and Construction Inspection
  - 16.5 Colorado Statutes Relating to Dams

# CHAPTER 1

## INTRODUCTION

### 1.1 INTENT OF THIS MANUAL

#### 1.1-1 GOAL

In the State of Colorado there are more than 2,200 water storage dams that are subject to the state's dam safety program. In the interest of public safety and of extending the useful life of these structures, this manual provides specific guidance that will enable the dam owner to carry out his responsibility to maintain a safe dam, avoid costly repairs, and prolong the life of the dam.

#### 1.1-2 METHOD

Information is provided on the basic workings of a dam, inspection and monitoring of a dam's performance, and general guidelines for carrying out routine maintenance. Additionally, suggested operating procedures, a model emergency preparedness plan, and a summary of related laws are included. This information is presented in a manner designed to help an inexperienced person become acquainted with the activities required to maintain a safe dam.

#### 1.1-3 IMPLEMENTATION

The goals mentioned above can be achieved through cooperation of the dam owners and the State dam Safety Engineers.

##### OWNERS

Dam owners are liable for all damages associated with their dams should they fail or break. To minimize this liability, owners should carry out the following:

- a. Periodic visual inspection of the dam.
- b. Prompt reporting and correction of any adverse conditions found during the inspection.
- c. Monitoring of questionable conditions that may affect the safety of the dam.
- d. Performing regular periodic maintenance when required.
- e. Retaining an experienced engineer to provide the investigations, analyses, reports, plans, and specifications required for the construction of new dams and for the improvement or safe operation of existing dams.
- f. Making repairs where and to the extent required.
- g. Complying with the established laws, rules, and regulations pertaining to dam construction and operation.

##### OFFICE OF THE STATE ENGINEER

The State Engineer is responsible for:

- a. Evaluation of each dam and related structure to determine annually the safe storage level as required by CRS 1973 37-87-107 as amended.

- b. Assisting the owners by investigating questionable conditions that are found and advising them on prudent remedial action. These actions may include having the condition assessed by a consulting engineer.
- c. When unsafe conditions are found, ordering required repairs and reduced storage levels until the repairs are completed.
- d. Reviewing plans and specifications for the construction of new dams and major repairs, alterations, and enlargements to existing dams. These are thoroughly evaluated for compliance with current dam safety standards, design criteria, and state requirements.
- e. Periodic on-site inspection of construction procedures and quality control techniques to verify conformance with approved plans and specifications.

#### 1.1-4 BENEFITS

By using proper inspection and maintenance procedures, dam owners can achieve an increased degree of safety for the structure. Timely inspection and maintenance will also reduce the possibility of loss of use of the structure and the need for costly repairs.

### 1.2 DEFINITION OF A DAM

Dams addressed in this manual are man-made barriers, constructed on natural terrain in order to control or store water. In most cases the reservoir basin is sited entirely in unaltered natural terrain. Natural lakes which have been developed by constructing facilities for releasing the lakes' contents are also included.

### 1.3 MINIMUM EXPECTED EFFORT BY THE OWNER

Unfortunately there is a possibility, however remote, that any given dam might experience partial or total failure, causing extensive damage in the downstream flood plain.

Minimum expected effort is the amount and intensity of effort the owner must make in fulfilling his obligation to persons and properties downstream from his dam to assure the dam does not experience damaging partial or total failure. The required actions include thorough visual inspection, accurate monitoring when required, recording and interpreting information gained from inspection and monitoring, regularly scheduled routine maintenance, making required repairs in a timely manner, and operating the dam in a way that will give the greatest assurance of safety. The required intensity of effort will vary in relation to the loss that would be experienced in terms of loss of life, the downstream development, and the value of the structure itself. The suggested ranges of effort required for the following types of dams are:

**HIGH HAZARD DAMS** — Failure of the dam would cause extensive property damage and would probably cause the loss of human life.

Daily — Surveillance by the owner or caretaker.

Weekly — Monitoring of seepage.

Monthly — Thorough visual inspection. Gathering, immediately plotting, and interpreting observation well and piezometer data.

Annually — Reading horizontal and vertical control monuments (more frequently if necessary).

Test operation of outlet and spillway mechanical components.

Routine maintenance as required.

**MODERATE HAZARD DAMS** — Failure of the dam would cause extensive property damage but is not expected to cause loss of human life.

Weekly — Surveillance by the owner or caretaker. Monitoring of seepage.

Monthly — Thorough visual inspection when storage is in excess of one-half the maximum gage rod reading. Gathering, plotting and interpreting observation well and piezometer data when storage is in excess of one-half the maximum gage rod reading.

Annually — Test operation of outlet and spillway mechanical components.

Reading of horizontal and vertical control monuments after a satisfactory performance record has been established for the dam.

Routine maintenance as required.

**LOW HAZARD DAMS** — Failure would cause little damage beyond the loss of the dam structure itself.

Monthly — Surveillance by the owner or caretaker. Monitoring of seepage when storage is in excess of one-half the maximum gage rod reading. Gathering, plotting, and interpreting observation well and piezometer data when storage is in excess of one-half the maximum gage rod reading.

Annually — Thorough visual inspection. (If the reservoir is full all year, visual inspection should be done quarterly.) Testing operation of the outlet works.

Every Five Years — Reading of horizontal and vertical control monuments after a satisfactory performance record has been established.

Routine maintenance as required.

## 1.4 CRITICAL CONDITIONS

### Floods

When floods caused by severe rainstorms, or excessive snowmelt runoff are predicted, the spillways of all dams should be inspected to detect any areas that will need special protection while passing the flood flows. During the flood and after flows subside, the spillway should be inspected to identify any damage needing repair.

### Windstorm

High winds can cause damaging wave action. The upstream slope must be monitored during severe windstorms to allow prompt repair of damaged areas. Thorough inspection when the storm subsides will allow required maintenance to be identified and prompt repairs initiated.

### Earthquake

If the effects of an earthquake are identified in the area of the dam site or if tremors have been reported, the dam should be thoroughly inspected immediately and at weekly intervals for four to six weeks after the quake. Conditions triggered by an earthquake can often take several weeks to appear.



PHOTO 1.4-1  
RUNOFF DAMAGE

FLOWS ERODING UNPROTECTED SPILLWAY CHANNEL. Sandbags and plastic sheet placed on right side to divert flow. Note full outlet discharge to minimize flow through spillway.



PHOTO 1.4-2  
WINDSTORM DAMAGE

Large cavern eroded into embankment after wave action destroyed concrete protective coating on the upstream face.



**PHOTO 1.4-3**  
**EARTHQUAKE DAMAGE**

Settlement of 2.5 feet on dam crest first noted about 2 weeks after an earthquake in the area.

#### 1.5 LIFE EXPECTANCY OF A DAM

One of the most compelling economic concerns of a dam owner is how to prolong the useful life of his dam. The oldest dam in the United States as shown on the National Inventory of Dams is known as Podunc Pond, located on the Podunc River near the town of Pleasant Valley, Connecticut. This 17-foot-high dam, impounding 110 acre feet, was constructed in 1730 and has been in service more than 250 years.

In Colorado, extensive dam building was initiated in the early 1900s, utilizing the engineering know-how and construction techniques available at that time. These dams, which were located in sparsely populated rural areas, occasionally experienced partial failure which caused little damage in the downstream flood plain. Historically, the required repairs were made as quickly as economic conditions permitted. Although these older dams were built without some of the safety-oriented features included in recently constructed dams, their useful lives can be extended greatly if the owners exercise the appropriate effort to assure the dams remain in good condition. Providing the money necessary to carry out periodic maintenance and required repairs is essential to prolong the life of the dam.

The recently published costs of proposed or newly constructed water storage projects clearly indicate that making all possible effort to keep an older structure in service is preferable to attempting to build a new dam.

When an owner constructs a new dam he should ensure, at the end of construction, that all portions of the structure are at the line and grade specified on the approved plans. This will allow inspection and monitoring to be carried out with a reliability level that will help assure the safety and longevity of the new dam.



**PHOTO 1.5**  
**EARLY CONSTRUCTION**  
**METHODS TYPICAL OF AN EARLIER ERA.**

#### 1.6 NEED FOR STORED WATER

Colorado is a semi-arid region with average annual precipitation being less than 16 inches per year. The early settlers quickly found that natural precipitation was not adequate to support their farming efforts. Runoff from snowpack in the high mountain areas usually is finished by early July and natural precipitation is usually not sufficient to bring irrigated crops to maturity. Control of the runoff for future use becomes vital, since most streams receiving snow melt produce two-thirds of their annual volume of runoff in May, June and July.

The critical need for stored water which can be made available on demand is present in all areas of the state.

Owners of these dams play a vital role in society by making water available for the various required uses. Although the use of the stored water directly benefits the owner, a number of the secondary benefits are enjoyed by people in the community.

#### 1.7 ROLE OF THE DAM OWNER

Initially the dam owner identifies the need for the project, finds a method to finance and reimburse project costs, then contracts for the design and construction work. Even before construction is complete, the owner assumes liability for any type of damage that might occur because of the uncontrolled release of stored water. Although a great number of people enjoy the benefits provided by the dam and reservoir, the owner has total responsibility for the dam's safety, and must provide the funds and effort necessary to obtain the maximum useful life from the structure.

#### 1.8 DAM SAFETY ROLE OF THE STATE ENGINEER

Colorado statutes charge the State Engineer with responsibility for public safety in relation to dams. This responsibility is addressed by three primary areas of activity:

- a. Physical inspection of dams. Based on conditions identified during these inspections, the dam owners are directed to take action to correct any deficiencies and required storage restrictions are ordered to assure the safe operation of the dam. These inspections are conducted by experienced registered professional engineers in the Dam Safety Branch. Follow up of the inspection often includes



reviewing questionable conditions on site with the dam owner, explaining the problems and suggesting the best and/or most economical way to proceed in assuring the dam's safety. Frequently, further studies by a consulting engineer are recommended.

- b. Review of plans and specifications for new dam projects and major repair work, enlargement, or rehabilitation of existing dams for conformance with design standards and effective construction techniques. Experienced registered professional engineers in the Dam Safety Branch conduct these reviews and work closely with the design engineers in order to provide a safe and workable design and construction plan.
- c. Periodic inspection of construction work being done on new or existing dams. These inspections are performed in order to verify that the work conforms to the approved plans and specifications. Any problem that is noted is discussed with the project engineer and corrective action is identified and implemented.

#### 1.9 USE OF AVAILABLE STAFF

In order to provide maximum utilization of available manpower, the following dam safety priorities have been established:

1. **ENSURE PUBLIC SAFETY** — Both the field inspection and design review activities are specifically directed toward public safety. All possible effort is made to assure that each dam remains in a safe condition. If problems are found during an inspection which threaten the safety of the dam, temporary reductions in storage behind the dam are ordered until required repairs are made.

When plans are submitted for repairs to existing dams, both these plans and original construction plans as well as known site conditions are scrutinized to assure that all potential problem areas have been properly addressed and the completed repairs will make the dam safe.

2. **MAXIMIZE THE SAFE STORAGE CAPACITY AVAILABLE WITHIN THE STATE** — This usually involves cooperation among the dam owner, his consulting engineer, and the State Engineer. Efforts are focused on resolving problems that cause the reservoir to be operated at a restricted level in the interest of public safety.

3. **PROVIDE DIRECTION AND ASSISTANCE TO OWNERS OF DAMS THAT ARE OPERATING AT FULL STORAGE CAPACITY** — Required monitoring, operational schedules, and maintenance that will help assure the safety of the dam and contribute to its longevity are communicated to and discussed with dam owners for their implementation.

#### 1.10 ROLE OF THE CONSULTING ENGINEER

The consulting engineering community is deeply involved in the total process of planning, designing, constructing, evaluating, and maintaining water storage dams. Their research and expertise can often provide the critical balance that determines whether a proposed project can be justified economically. This engineering community has the responsibility to design and construct water storage facilities according to the most recently proven technology in design and efficient construction practice.

Dams are constructed largely of locally available natural materials and are founded on natural materials. Natural materials vary widely in their characteristics and distribution from site to site and within a given site. Engineering services for dam design and construction monitoring are often extensive and time consuming because of the unique conditions to be evaluated at each dam site. There is no such thing as a standard dam design. Engineering investigations and studies are required to develop a reasonably economical and serviceable dam project.

#### SUMMARY

Water must be available on demand to meet the needs of society. Dams are constructed to provide water storage reservoirs to meet these needs, and with that construction the dam owner becomes solely responsible for the safety, safe operation, and long life of his dam. In addition, the State Engineer inspects the dams and regulates dam construction in order to assure public safety. By a cooperative effort between the dam owner, the State Engineer, and the consulting engineering community, dams can be constructed and maintained in accordance with the highest safety standards. This manual provides information that will assist the dam owner in effectively carrying out his responsibility to public safety and extending the useful life of his dam.

**2.1 INTRODUCTION**

This chapter presents some of the physical principles that make it possible for a dam to hold water. Knowledge of what allows the dam to function will help the owner to understand why various inspection and maintenance items must be performed.

**2.2 SOILS FOR CONSTRUCTION**

Soil is the material on the earth's surface produced by the breakdown of rock due to weathering and erosion.

Soils used in construction usually serve the following functions:

1. Provide weight and/or stability.
2. Provide resistance to the flow of water.
3. Provide for the controlled flow of water.

Soils normally encountered in earth embankments contain a mixture of sands, silts, clays, and rock fragments. The individual particles range in size from microscopic to approximately an 8-inch maximum dimension. Soil types are identified based on the predominant particle size.

Silt and clay have different degrees of plastic behavior. A clay can be molded into a shape, while silt will break up when attempts are made to mold it. Some characteristics of sand, silt, and clay for use in a dam are examined below.

**2.3 PARTICLE SIZE**

Particle size is especially important because it influences the flow of water through a soil mass. A comparison of average sizes of various soil components is shown below. The dimension of a clay particle will be assigned **one unit** to allow comparisons among sand, silt, clay, and water.

ITEM	SIZE RANGE METRIC UNITS	ENGLISH UNITS
Rock	76.2 MM → 2M	2.9 In. → 6.56 Ft.
Gravel	4.76MM → 76.2MM	0.19 → 2.9 In.
Sand	0.074 → 2.0MM	0.003 → 0.079 In.

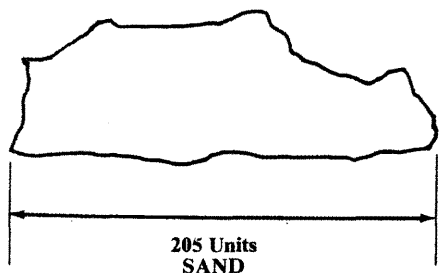

Silt      0.005 → 0.074MM    0.0002 → 0.003 In.

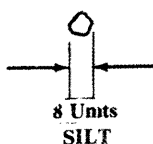

Clay      Smaller than .005MM    Smaller than 0.0002 In.



Water Molecule    0.00000003MM    0.000000001 In.

If the clay particle and a water molecule are each magnified 65,000 times, the water molecule can barely be seen.

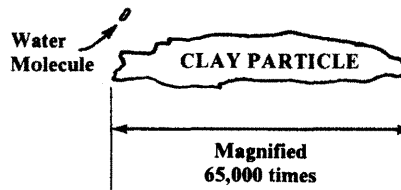

FIGURE 2.3-1 PARTICLE SIZE

**2.4 SOIL STRUCTURE**

Any natural deposit of soil will contain various size particles and spaces called **voids** which are filled with air or water. A useful material for demonstrating soil structure is sand of the type found on the beach or in children's sand boxes.

In illustrations of soil structure, these symbols will be used:

- Water — A droplet of water.  
 This droplet is normally made up of many molecules.
- Air — A small bubble of air.
- Sand — A sand grain.
- Silt — Will be shown larger than actual size indicated in Figure 2.3-1.
- Clay — Will be shown very much larger than indicated in Figure 2.3-1 for ease of illustration.

**a. SAND**

A sample is prepared by placing a few shovels full of dry sand into a mound. Water is now sprinkled on the mound until some water begins to flow away from the base. The sand is allowed to drain for a few minutes. A small sample is taken and pressed or molded in the hand.

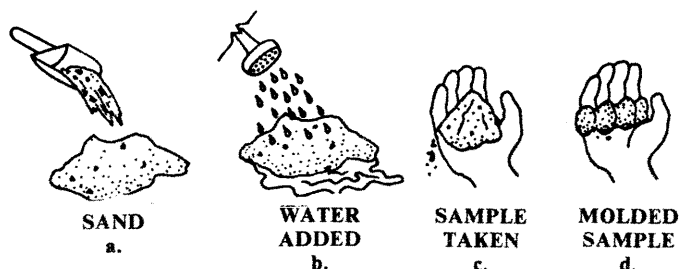
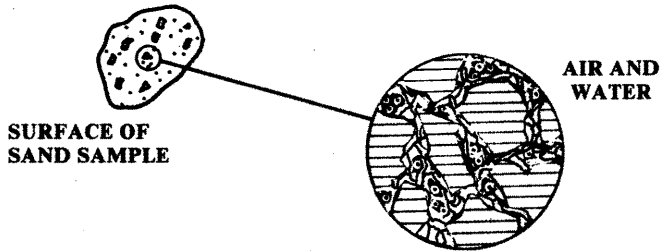

FIGURE 2.4-1 SAMPLE PREPARATION

Imagine that this sample is carefully sliced in half. Placed under a powerful magnifier, the sliced surface would look like that shown in Figure 2.4-2.



**MAGNIFIED VIEW**

**FIGURE 2.4-2 SAND STRUCTURE**

Sand particles occupy the largest portion of the area viewed. Air and water occupy the remainder of the area.

**b. SILT**

A silt material is prepared in a similar manner to the sand. The structure will contain silt particles, water and air. The sliced surface of the silt sample under a powerful magnifier would appear much like that shown below.

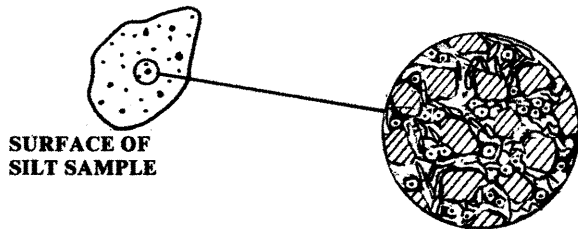

**MAGNIFIED VIEW**

**FIGURE 2.4-3 SILT STRUCTURE**

Again we see that the silt particles make up the majority of the area but are interlaced with air and water.

**c. CLAY**

A similarly prepared sample of clay must be viewed under a microscope. We see that the clay particles are interlaced with air and water.

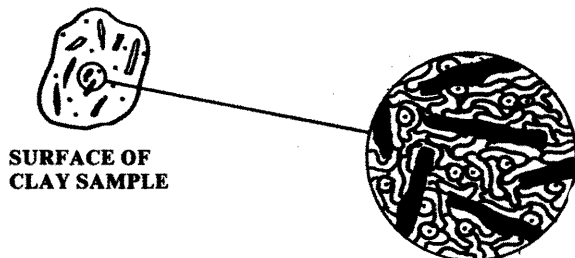

**MAGNIFIED VIEW**

**FIGURE 2.4-4 CLAY STRUCTURE**

Very small droplets of water and air bubbles take up a portion of the area viewed.

**d. NATURAL DEPOSIT**

A sample of a natural deposit of soil can contain a combination of rock, gravel, sand, silt, and clay. It can also include some organic material and of course will contain air and water.

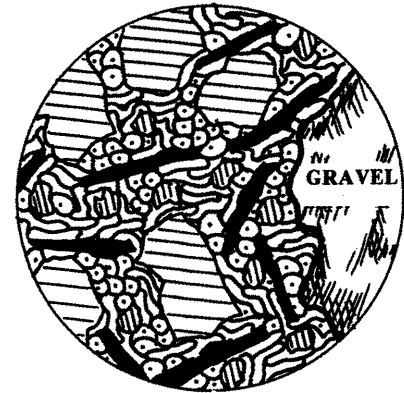

**MAGNIFIED VIEW**

**FIGURE 2.4-5 STRUCTURE OF NATURAL DEPOSIT**

These examples show that any soil deposit contains water and air in addition to the solid soil particles. The voids that are filled by the air and water provide pathways for water to flow through the soil. By reducing the number of voids, the soil will contain fewer pathways for flow.

**2.5 COMPACTION**

The sand sample contains large amounts of water and air. The only change from its natural condition after adding water is the application of pressure by hand. What can be done to reduce the amount of air and water in the sample to allow fewer spaces for flow? Squeezing on it harder seems to be a logical answer; that is, applying more pressure to the sample.

Applying greater pressure to the sample will reduce the amount of space available for air and water in two ways:

1. The air between grains can be squeezed out, reducing the void areas.

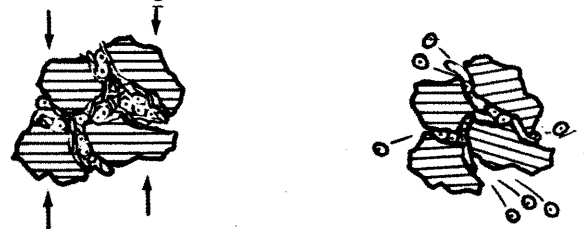

**FIGURE 2.5-1 REDUCING VOIDS**

2. Fragments are broken off from some particles, or particles are deformed, allowing the void area to be reduced further.

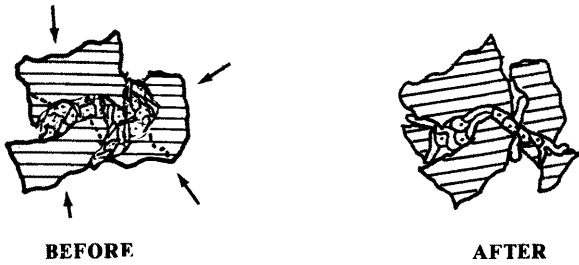

FIGURE 2.5-2 BREAKAGE CAUSES ADDITIONAL REDUCTION OF VOIDS.

Also note that the sand grain surfaces in contact with each other have increased after the application of additional pressure.

Compaction is usually obtained by applying an impact force to the surface of the soil as shown in the example below. The soil used will contain equal parts of sand, silt, and clay.

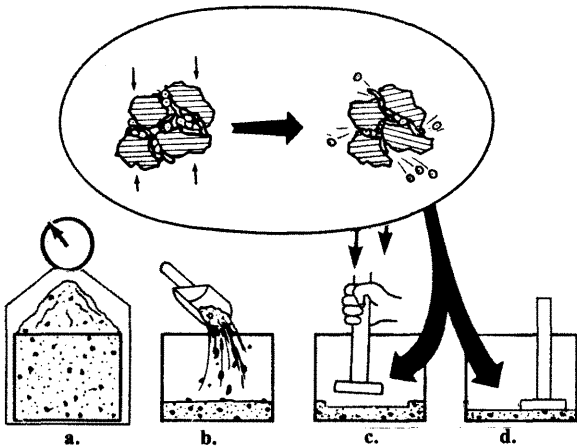

FIGURE 2.5-3 THE COMPACTION PROCESS

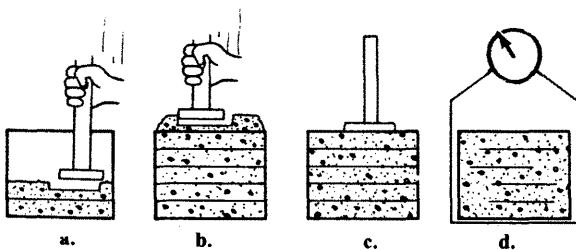

FIGURE 2.5-4 COMPACTION IN LAYERS

In Figure 2.5-3 c, a tamping tool is used to pound a 3-inch layer of soil with enough force to create an imprint about 1/2 inch deep. The pounding is continued until the entire surface of the sample has been compacted. (See Figure 2.5-3 d.)

Now the soil layer that was 3 inches thick is only 2 1/2 inches thick, although it contains the same amount of soil particles. Most of the air has been forced out of the soil sample.

In order to fill the container with a soil of uniform density, successive 3-inch layers are placed, then compacted to a 2 1/2-inch thickness, as shown in Figure 2.5-4.

Compaction is required to attain a number of positive changes in a soil:

The area available for water to flow through is reduced.

The strength of the soil is increased because of the increased particle-to-particle contact.

The properties of the soil become more predictable.

The soil has increased resistance to erosion.

The soil provides more weight per volume (more solid particles).

2.5-1 **PLACEMENT IN LAYERS** — was used in order to obtain a uniformly dense material. Since placing the materials in layers requires a lot of work, is it necessary? Let us take a look at a compaction procedure similar to the one above; however, this time the container will not be filled in layers, but will be filled close to the top before the material is pounded with the tamping tool.

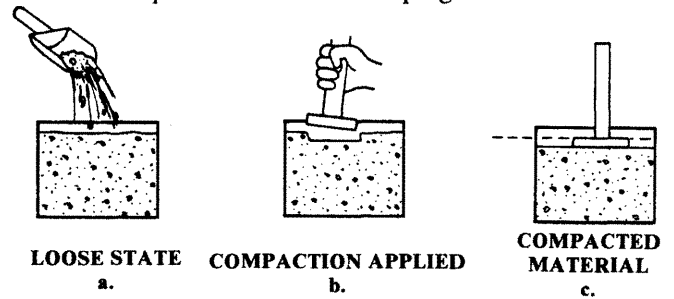

FIGURE 2.5-5 COMPACTION WITHOUT LAYERS

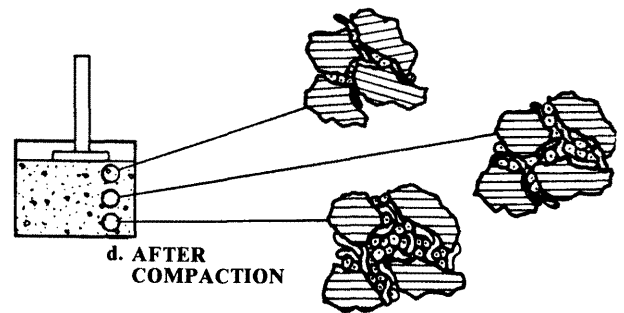

FIGURE 2.5-6 RESULT OF COMPACTION WITHOUT CONTROLLED LAYERS.

Figure 2.5-5d shows that only the upper portion of the material has become compacted, the middle portion shows only a small change from the loose state, and the bottom portion of the sample is unchanged from the loose state (Figure 2.5-5a). The primary reason for this is the way the impact from the tamping tool is transmitted through the soil.

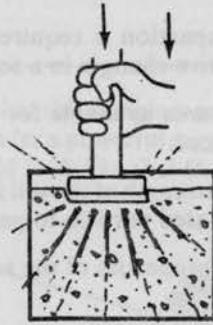

FIGURE 2.5-6 TRANSMISSION OF COMPACTION FORCE

The pressure directly under the foot of the tool is fairly uniform; however, as the depth increases, the impact is spread out over a greater area and has less effect on the soil. Also, in the lower parts of the sample, the impact is not great enough to cause the grains to break or move against each other.

The examples shown in Figures 2.5-3 through 2.5-6 illustrate why it is necessary to place a soil in controlled layers in order to obtain a uniformly dense material. The thickness of the layer that can be effectively compacted depends on the type and weight of the equipment being used. Figures 2.5-7 through 2.5-11 show various types of compaction equipment.

#### 2.5-2 VIBRATION AIDS IN COMPACTION

Soil materials having contact surfaces that resist particle-to-particle movement can be compacted more effectively when vibration is applied. Usually rocks, cobble, gravel, and sands require vibration in addition to impact force in order to obtain the desired compaction. Figure 2.5-11 shows a vibrating roller which is equipped with a mechanism that causes the roller drums to vibrate as it passes over the material being compacted.

#### 2.5-3 COMPACTION EQUIPMENT

Some of the more common compaction equipment is shown here.



FIGURE 2.5-7 — POGO STICK, SIMILAR TO TAMPING TOOL. — Is used in tight spots not accessible to larger equipment.

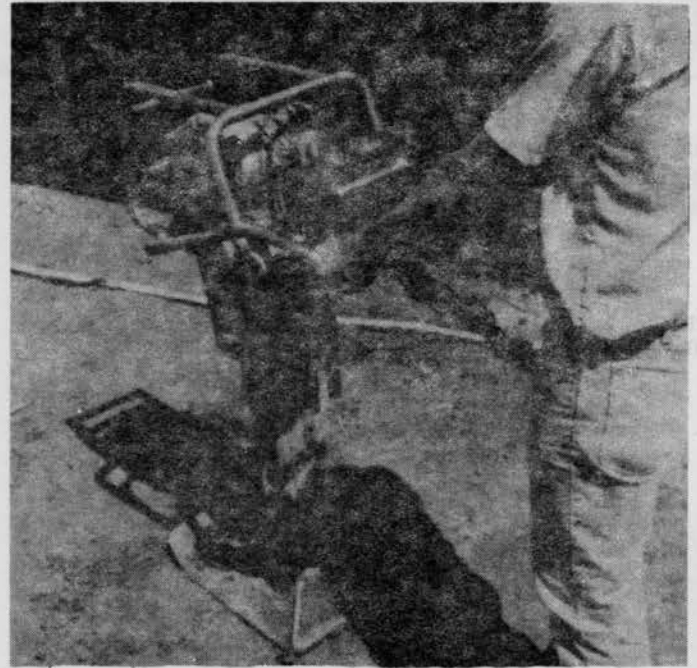

FIGURE 2.5-8 — WACKER. — Is used in areas larger equipment cannot reach.



FIGURE 2.5-9 — SHEEPSFOOT ROLLER. — Used in open areas.

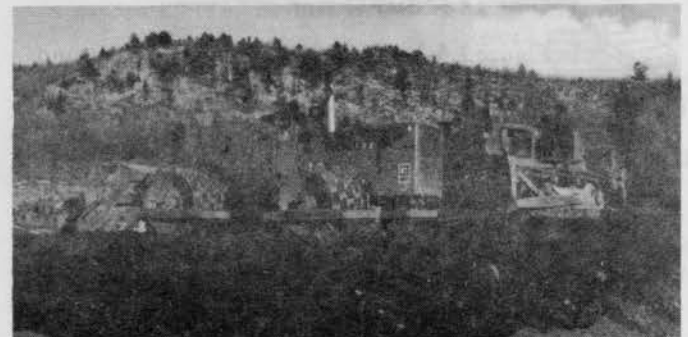
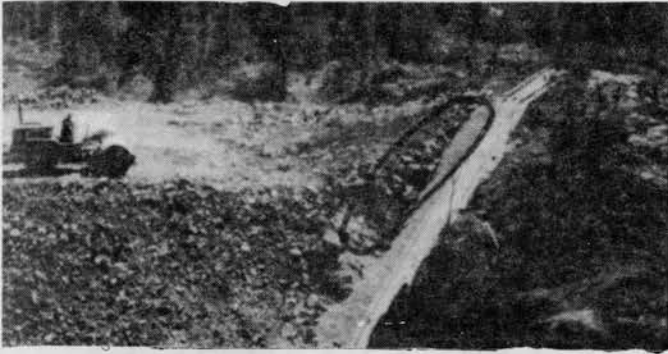

FIGURE 2.5-10 — SELF-PROPELLED ROLLER. — Used in open areas.

As can be seen, the pogo stick and wacker are much smaller and lighter than the sheepsfoot and self-propelled roller. Soils compacted with the lighter equipment must be placed in thin layers not exceeding 4 inches, while soils compacted by the heavier equipment can be placed in layers up to 12 inches.

**FIGURE 2.5-11 — VIBRATORY ROLLER.**  
Drums vibrate as roller moves.



**2.6 MOISTURE CONTROL**

The amount of moisture (water) contained in a soil prior to placement determines several important characteristics of the material during and after compaction:

How easy the material is to work with (e.g., not mud or dust).

How much effort will be required to obtain the greatest practical density.

How dense a soil can be made by a given amount of compactive effort.

The moisture content of the soil under consideration falls into three categories:

**Optimum (just right)** — When the moisture content is at the Optimum Level, there is just enough moisture to allow most grains or particles of soil to move or slide into a more compact structure while the air filling a significant portion of voids in the soil is forced out.

**AT OPTIMUM MOISTURE CONTENT, A GIVEN COMPACTIVE EFFORT WILL PRODUCE THE GREATEST DENSITY.**

**Too Dry** — When not enough moisture is present, the grains or particles resist change or movement between surfaces and the material does not reach the desired density after application of a specified compactive effort.

**Too Wet** — When too much water is present, it allows water to fill a large portion of the voids in the sample. When compactive effort is applied, the pressure is transferred to the water and air, resulting in little change in the soil structure.

**2.7 COMPARISON OF PATHWAYS AVAILABLE FOR THE FLOW OF WATER THROUGH A GIVEN MATERIAL**

We have seen how the structure of sand, silt, and clay provide very different patterns or pathways for the flow of water through the soil. In order to give a comparison of the area available for water to flow through various materials, the following illustration is presented. These commonly used materials will be shown:

- Sand — properly compacted
- Silt — properly compacted
- Clay — properly compacted
- Concrete — properly placed
- Asphalt — properly compacted
- One-fourth inch steel plate — in new condition

To establish a basis for quick comparison, a shaded square will be used to represent the portion of solid particles and the portion of voids (normally filled by water or air) of a given area of a material we are viewing. The area representing the solid portion is shaded and the void area is clear.

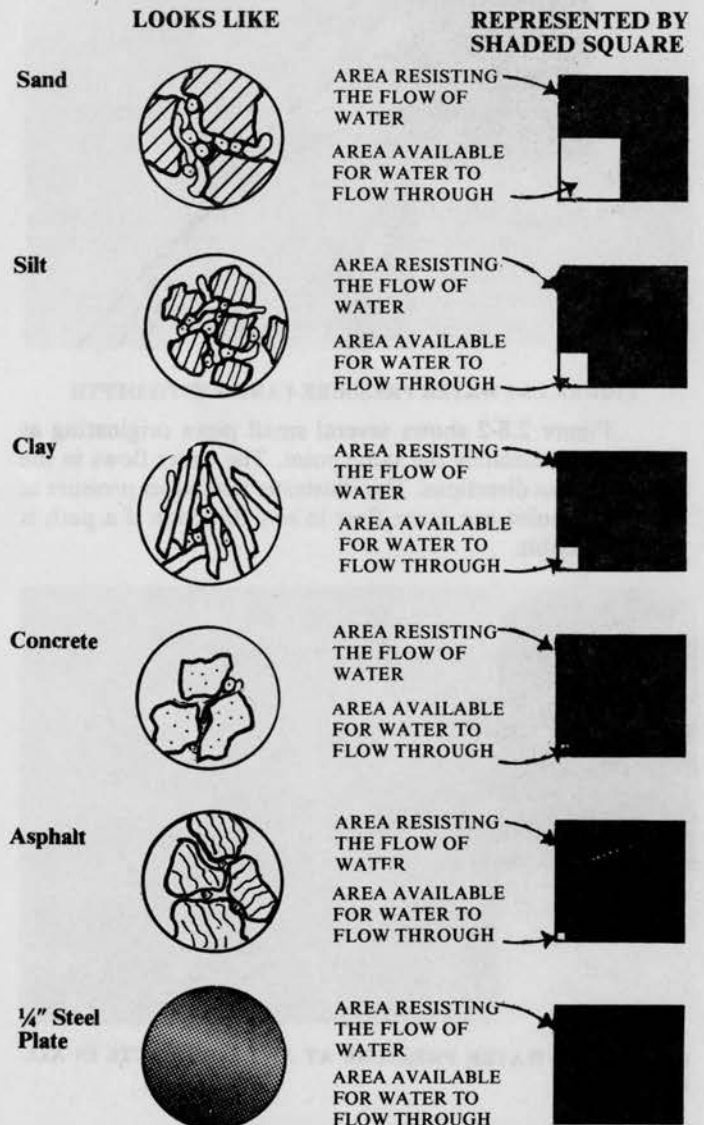

**FIGURE 2.7-1 — COMPARISON OF AREA AVAILABLE FOR WATER TO FLOW THROUGH . (NOT TO SCALE)**

These comparisons are intended to rank or order the materials in terms of how much area or how many pathways are available for water to flow through. A larger void area reduces the soil's ability to resist the flow of water.

## 2.8 WATER PRESSURE

An understanding of two aspects of water behavior is important in understanding why water tends to flow through a soil. These are:

1. The pressure exerted at any point in a body of water increases with increased depth below the water surface.
2. The water pressure exerted at a point can act in any direction.

Figure 2.8-1 shows a container with three holes of the same size along one side. Water flowing from the bottom hole moves much further horizontally because of the increased pressure at that exit point.

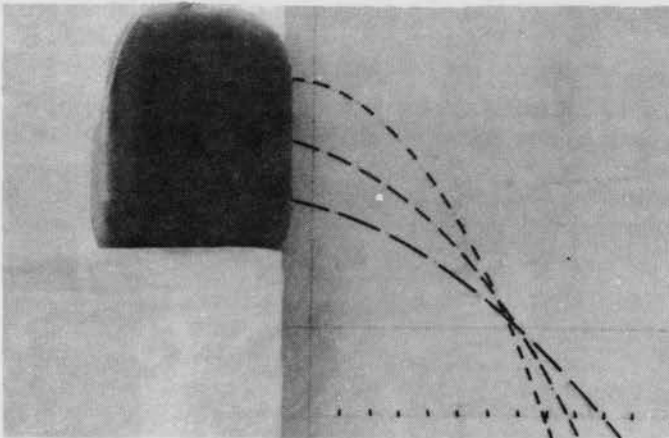

FIGURE 2.8-1 WATER PRESSURE VARIES WITH DEPTH

Figure 2.8-2 shows several small pipes originating at approximately the same point. The water flows in the various directions. This illustrates that water pressure at any point can cause flow in any direction if a path is available.

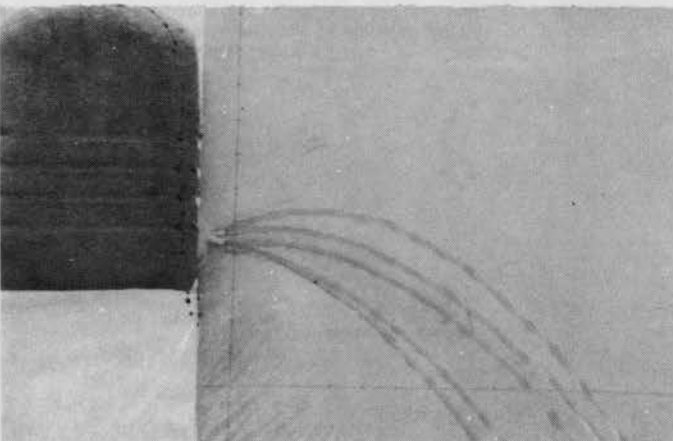

FIGURE 2.8-2 WATER PRESSURE AT ANY POINT ACTS IN ALL DIRECTIONS

## 2.9 FLOW PATH

2.9-1 **Flow Path** is the approximate line or path a droplet or molecule of water takes when moving through a material.

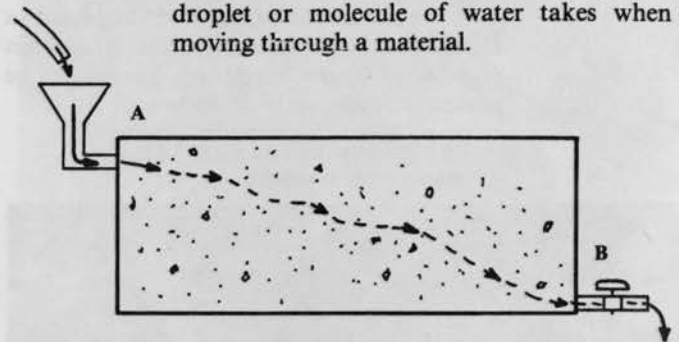

FIGURE 2.9-1 FLOW PATH OF WATER MOVING THROUGH SAND-FILLED CONTAINER.

In the above figure water is introduced into a sand-filled container at the top and exits through the pipe in the side. The path water takes through the container is called the flow path.

A droplet of water moves along a flow path from an initial contact point A with a material or combination of materials to some exit point B from those materials.

Point A, Figure 2.9-1, is where the water droplet contacts the sand material and Point B is where that same droplet exits the material and begins moving under the influence of gravity alone.

## 2.10 LENGTHENING THE FLOW PATH

In the experiment shown here the quantity of flow through a compacted sand material contained in a  $\frac{3}{8}$ -inch diameter tube was reduced about  $5\frac{1}{2}\%$  for each 1-inch unit of increased flow path when subjected to a constant water pressure. This illustrates that lengthening of the flow path can help reduce flow through the material.

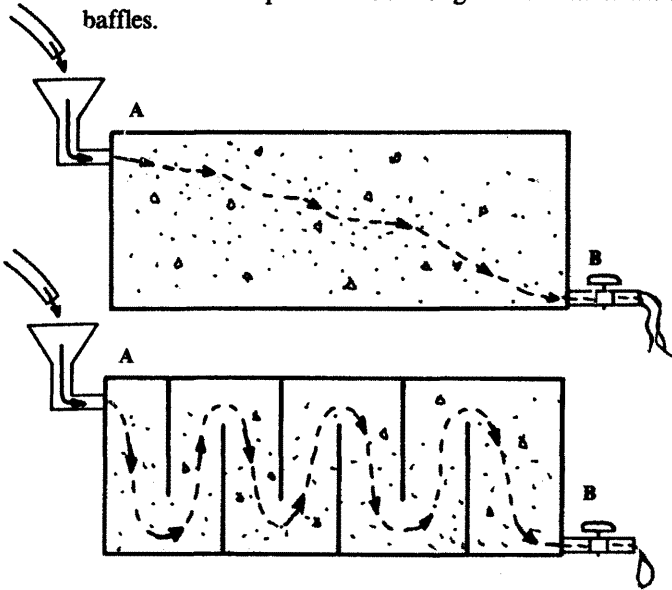

FIGURE 2.10-1  
REDUCED AMOUNT OF FLOW CAUSED BY LENGTHENING THE FLOW PATH

By increasing the length of the path through the same material, the amount of flow is reduced.

Another example of increased flow path is shown here. Two identically sized tanks are made. One of the tanks is equipped with a series of alternating baffles which are waterproof. Both tanks are filled with sand. Each tank is

filled with water; then the valve is opened. By regulating the inflow, the water level is kept at Point A for both tanks. The flow path is much longer in the tank with baffles.



**FIGURE 2.10-2 ANOTHER WAY TO INCREASE THE FLOW PATH**  
Although the height of water above Point B is equal for both tanks the flow from the tank having the longer flow path will be much less.

## 2.11 SUMMARY

1. Soil is an essential construction material.
2. Particle size and type of soil determine many of its construction properties.
3. Soil composition and compactness influence how water can flow through that soil.
4. Compaction of a soil reduces the area available for water to flow through and increases soil strength.
5. Controlled layer placement is required for proper compaction.
6. Moisture control is vital to producing the most dense compacted soil material.
7. Water pressure at a point increases directly as the height of water above the point increases.
8. Water pressure at a point will cause flow in any direction if a flow path is available.
9. Lengthening the flow path through a given material reduces the amount of water that will flow through the material.



1. **UPSTREAM SLOPE** — This is the part of the dam that is in contact with the reservoir water. On earthen dams the upstream slope must be protected from the erosive action of waves by rock riprap, concrete or some other material.
2. **CREST** — The top part of the dam. Usually a roadway is established across the crest to provide access to the dam for operation, inspection and maintenance.
3. **DOWNSTREAM SLOPE** — This is the slope or face of the dam away from the reservoir water. This area requires some form of protection, such as grass, from the erosive effects of rain and surface flows.
4. **PRINCIPAL SPILLWAY** — Allows discharge of water from the reservoir when the water level exceeds the top of the principal spillway. Principal spillways are used to allow small inflows to be released from the reservoir.
5. **EMERGENCY SPILLWAY** — Allows the inflow from large storms to be released from the reservoir before the water level rises high enough to overtop the dam.
6. **OUTLET DISCHARGE STRUCTURE** — This structure protects the downstream end of the outlet pipe from erosion and is often designed to slow down the velocity of released water to prevent erosion of the stream channel.
7. **OUTLET CONTROL HOUSE** — Protects the operating mechanism for the outlet control valve from weather and from vandalism.
8. **ENERGY DISSIPATOR** — This structure slows the fast moving spillway flows in order to prevent erosion of the stream channel.
9. **STILLING BASIN** — An area where spillway flows become equal to stream flow velocities.
10. **OUTFLOW CHANNEL** — A natural stream channel that transports reservoir releases.
11. **RESERVOIR** — A manmade facility for the storage and controlled release of water.
12. **LOG AND SAFETY BOOM** — A net like device installed to prevent logs, debris or boaters from entering a water discharge facility.
13. **GAGE ROD** — A measuring device that shows the water level in the reservoir.
14. **HORIZONTAL AND VERTICAL CONTROL POINTS** — These are small monuments that are securely embedded in the surface of the dam. Any movement of the monument indicates a movement in the dam itself. Movements are detected by using accurate survey procedures.
15. **PERMANENT MONUMENT** — Fixed monuments placed away from the dam which allow movements in the control points to be observed by using accurate survey procedures.
16. **PIEZOMETER (OPEN WELL)** — Allows the level of saturation within the dam to be measured.
17. **TOE DRAIN AND OUTFALL** — Carry seepage water away from the dam and can allow seepage quantities to be measured.
18. **ABUTMENT SEEPAGE** — Reservoir water that moves through seams or pores in the natural abutment material and exits as seepage.
19. **V-NOTCH WEIR** — A device for measuring the flow of water.
20. **SEEPAGE OUTFLOW DITCH** — A shallow ditch that is excavated to prevent seepage water from collecting in ponds.
21. **ACCESS ROAD** — A roadway that provides access to the dam.
22. **ACCESS GATE** — A sturdy gate to prevent unauthorized access and discourage vandalism.
23. **TURN AROUND** — Provided for the convenience of maintenance vehicles.

3.1 INTRODUCTION

As stated in Chapter 1, a dam is a man-made barrier constructed for the purpose of storing water.

Chapter 2 presented a few principles that relate to the flow and behavior of water in a soil material. Also, we illustrated soil structure and how compacted soils can successfully resist the flow of water under pressure and maintain their strength. Then soil's resistance to the flow of water was compared with other materials such as concrete and steel.

This chapter shows how the principles in Chapter 2 are used in the design of a dam to fulfill the purpose of safely holding back water. The chapter also illustrates how the principles affect the behavior of a dam.

Figure 3.1-1 is provided to assist the reader in identifying names of the features of a dam most often used by the engineering profession.

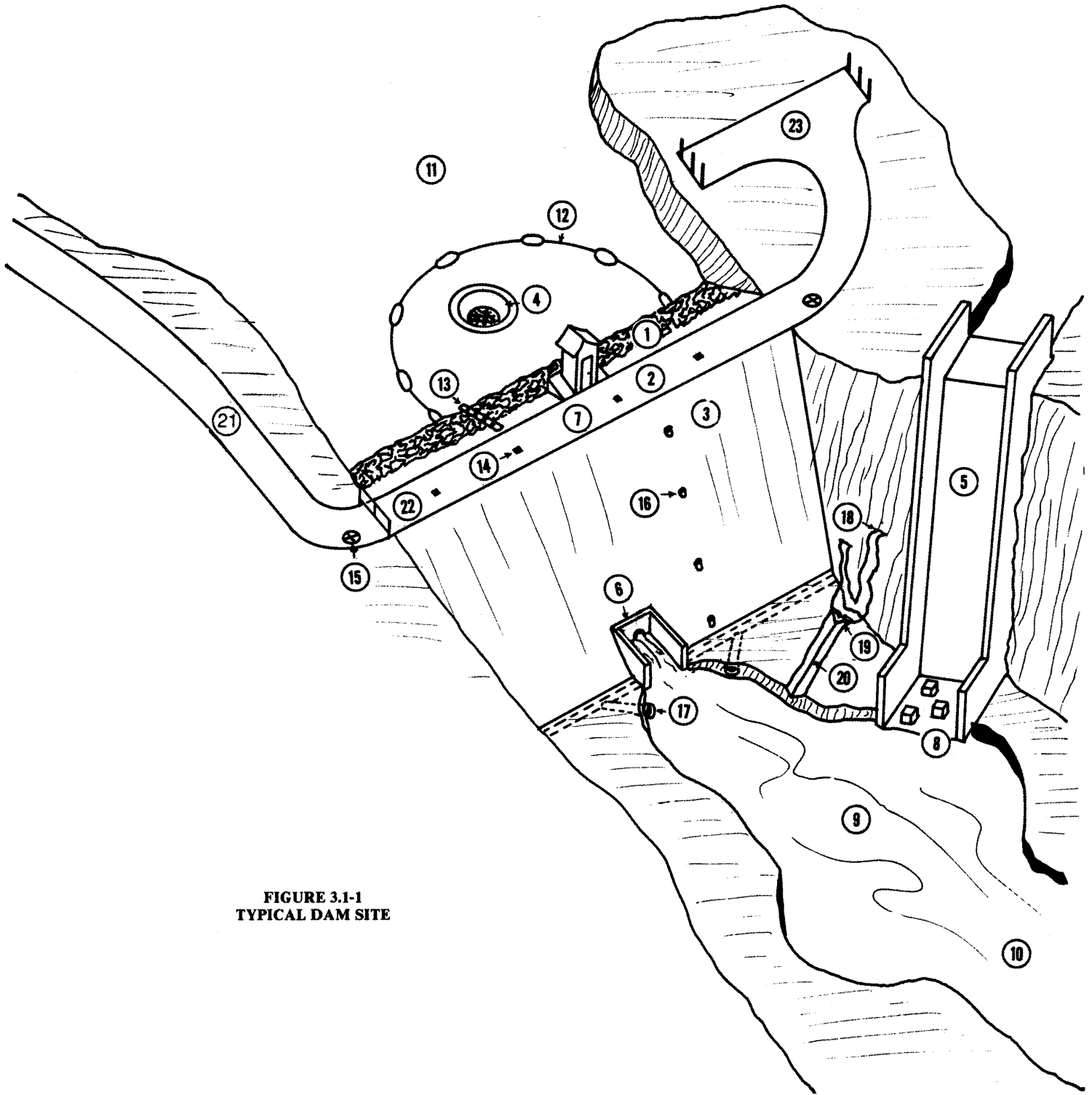

FIGURE 3.1-1  
TYPICAL DAM SITE

### 3.2 FUNCTIONS OF A DAM

The primary requirements of a dam in order to hold back water safely are:

1. Contain the water and resist leakage.
2. Maintain shape.
3. Resist movement in a downstream direction.

The greater the depth of stored water behind the dam, the greater the pressures are and the greater the resistance must be to leakage and movement. Resistance to leakage is important since the purpose of the dam is to store water. Resistance to movement is important too, because the pressure of the stored water tends to push the dam downstream. For example, the sketch below shows a concrete dam that would move downstream if it were not designed to resist the pressure of the water.

Indicates Water Surface

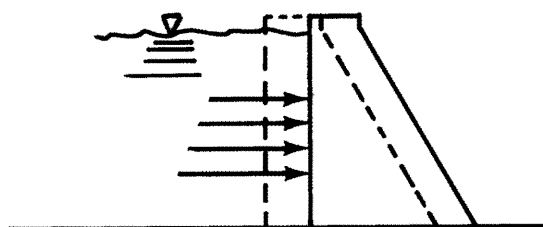

FIGURE 3.2-1

CONCRETE DAM WITH LOAD FROM RESERVOIR

The function of maintaining shape is more related to dams constructed of earth material or rock. The shape refers to the outline of the dam or the profile. The final shape of the dam is a result of design which determines the amount of material necessary to resist leakage and movement. If the shape of the dam changes, it may no longer be able to perform its required functions. The sketches below show that a slide has occurred and the dam can no longer hold back the water.

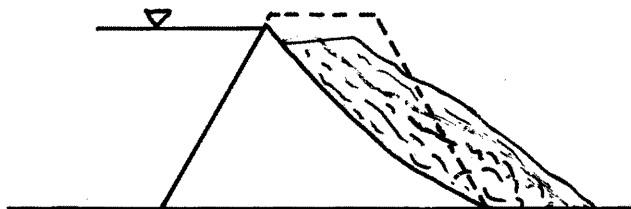

FIGURE 3.2-2

EARTH DAM — FAILS TO HOLD BACK WATER

The dam surroundings must also function as a unit. The site on which the dam is constructed becomes a part of the dam. The dam site has three important parts:

1. The foundation.
2. The abutments.
3. The reservoir basin.

The site is an integral part of the dam and must hold up the structure as well as help hold back the water.

#### 3.2-1 THE FOUNDATION

The part of the dam site which must support the dam is the foundation. Although other factors are involved, the first task of the foundation is provide firm support for the entire dam. A soft foundation, for example, would not support the weight of the dam.

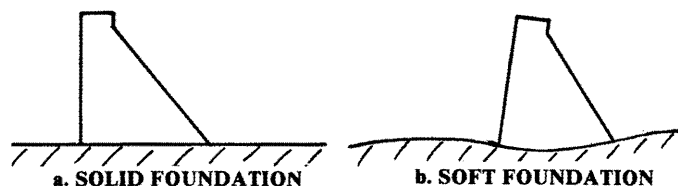

FIGURE 3.2-3  
FOUNDATION CONDITIONS

Because the purpose of the dam is storage of water, the foundation must also resist the flow of water under the structure. A clay material or unfractured hard rock, for example, would resist the flow of water under the structure much more effectively than sand or gravel.

#### 3.2-2 THE ABUTMENTS AND RESERVOIR BASIN

The other parts of the site which must be as strong as the foundation and resist the flow of water are the abutments. The abutments are the areas where the ends of the dam meet with the surrounding terrain.

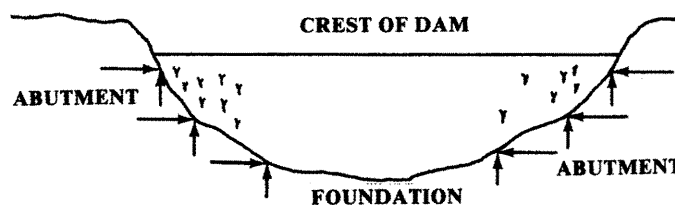

FIGURE 3.2-4  
THE DAM SITE

The abutments must offer support to the structure in the length-wise, upstream-downstream, and vertical directions.

The basin behind the dam or the area covered by the reservoir is just as important as the dam itself. Its size and shape determine the volume of the reservoir. Like the dam, the foundation, and the abutments, the basin must contain the water.

#### 3.2-3 THE DAM SITE

Unfortunately, nature does not always provide the most ideal site for a dam. Therefore, special designs and treatments of the site are necessary

in some cases to produce a useful storage facility. Many factors are involved in selecting the dam site.

The dam site **must** be able to:

1. Hold up the dam.
2. Hold the dam in place.
3. Hold back water.

Many times the type of dam selected is a result of the site conditions. Even though the best efforts are employed in site selection, design, and construction, all dams will experience some seepage.

Three types of dams are discussed in this chapter: earth, rockfill, and concrete. The discussion includes typical sections identifying the parts of each, the role of each part, and how each type of dam functions to achieve the primary purpose of holding back water safely.

### 3.3 REVIEW

The following list is provided for easy review and quick reference when looking at the details of the three types of dams:

#### Required Functions of a Dam

All dams must:

1. Contain the water and resist leakage.
2. Maintain shape.
3. Resist downstream movement.

The foundation, abutments, and reservoir basin must:

1. Hold up the dam.
2. Hold the dam in place.
3. Hold back the water.

#### Important Physical Principles

1. The greater the depth of water is above any point, the greater the pressure is at that point.
2. Water travels in streams, drops, and tiny droplets. Because the water molecule is small, special precautions must be taken to prevent excessive flow of water through earthen materials.
3. The amount of water that will move through a soil is determined by:
  - a. The height of water above the point being considered.
  - b. The type of material.
  - c. The amount of space available for the water to flow through the soil after compaction of that material.
  - d. The length of the flow path.
4. Proper moisture control allows an earthen material to be compacted efficiently. Proper compaction results in the fewest paths for seepage and the greatest strength.
5. Steel, concrete, and asphalt provide almost total resistance to the flow of water.

### 3.4 EARTH DAMS

Understanding the physical principle of how water behaves under pressure is primary to understanding the behavior of an earth dam. Let us look at a single drop of water at some depth in the reservoir. The pressure trying to force the drop of water through the dam is proportional to the height of water above the drop. The sketch below shows a droplet of water at Point A in the reservoir. The pressure forces the drop-

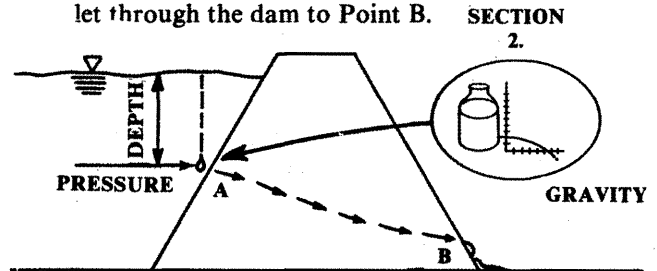

FIGURE 3.4-1  
SEEPAGE PATH

As the drop of water is pushed horizontally through the soil of the dam, gravity is also pulling the drop downward. The path is similar to that shown in the above sketch. Now, if we follow the paths of several drops of water at different depths in the reservoir, the pattern traced by the droplets is similar to that shown in the following sketch.

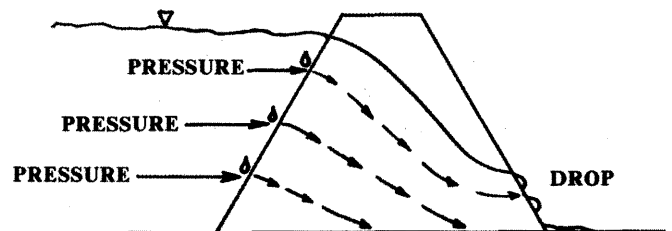

FIGURE 3.4-2  
FLOW PATH

The sketch above illustrates the concept of seepage through an earth dam. If the area available for flow in a given soil structure is changed, the paths will change. The items that will influence the area available for flow are material grain size and amount of compaction. If the material selected has larger grain size, or if it is not well compacted, the result is an unacceptable amount of seepage as shown in the following sketch.

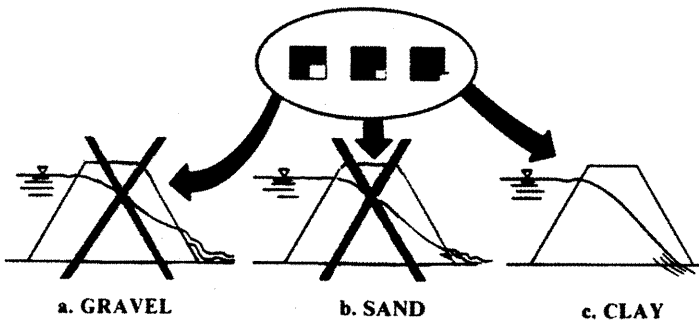

FIGURE 3.4-3 MATERIALS INFLUENCE FLOW PATH

The first two sketches represent undesirable conditions because **uncontrolled seepage** is exiting on the downstream slope of the dam. The situation develops because the structure does not provide sufficient resistance to the flow of water. Gravel and sand, because of their larger grain size, have more area available for flow than finer-grained material such as clay. Compacting clay soils further reduces the area available for flow. As the water moves through the soil structure, some of the pressure which is pushing it through the dam is dissipated. The path of the water must be made long enough to use up all the pressure pushing on the drop at point A by the time the drop reaches point B.

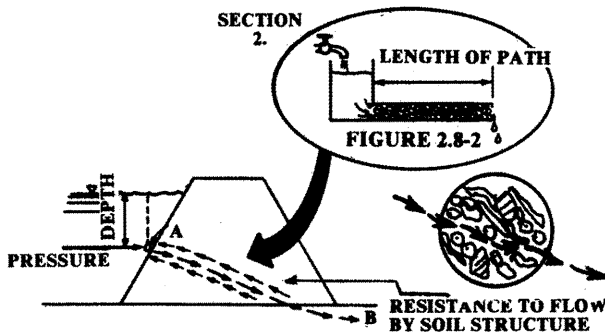

FIGURE 3.4-4 RESISTANCE TO FLOW

We have seen how the grain size of the material and the amount of compaction influences the area available for flow. For a given material, the length of the flow path will determine the amount of water that flows through as seepage. In the next section we will see how various configurations are used to control seepage, allow the dam to maintain its shape, and prevent downstream movement.

3.4-1 TYPICAL CONFIGURATIONS

The selection of shape and materials allows an effective dam to be constructed of locally available material. The following cross-sections represent three most common earth embankments.

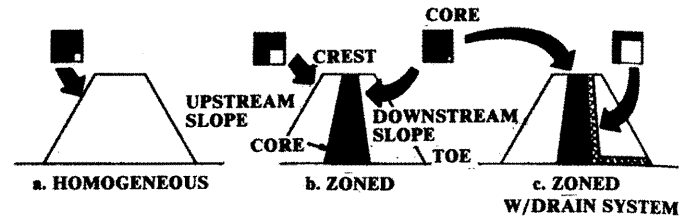

FIGURE 3.4-5 TYPICAL CROSS SECTIONS

Type:	Homogeneous	Zoned	Zoned w/Drain System
Characteristics	Constructed of one material.	Constructed of two or more materials. Central core or midsection has greater resistance to flow.	Drain system of granular material allows the controlled exit of seepage.

The three different cross sections are designed from knowledge of the principles used to control the path of the water through the dam:

1. Selection of material by grain size.
2. Compaction.
3. Elongation of the path by increasing the base width.

The homogeneous dam, for example, controls the flow of water by lengthening the path. The path is lengthened by increasing the base width; however, without drains seepage can exit the dam above the toe. The zoned dam provides control of the flow of water with a core having a very high resistance to flow.

The sketches below show the difference in the paths of water between a homogeneous dam and a zoned dam.

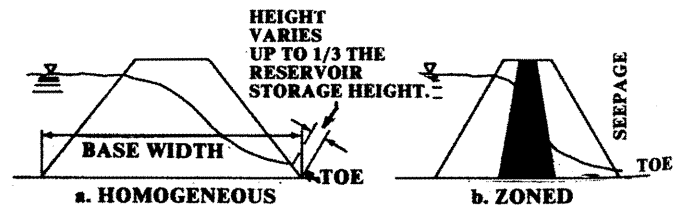

FIGURE 3.4-6 TYPE OF CROSS SECTION INFLUENCES FLOW PATH

The middle section (core) of the zoned dam has more resistance to flow and dissipates the pressure caused by the reservoir in a short distance.

In the case of the homogeneous dam, the height of visible seepage water near the toe can exit as high as 1/3 the height of the reservoir water surface. The appearance of water on the downstream slope can endanger the safety of the structure. Therefore, every effort is made in design of a dam to minimize the chance for water to exit on the downstream face.

In the case of the zoned dam with drain, a coarse-grained material is installed which has little resistance to the flow of water.

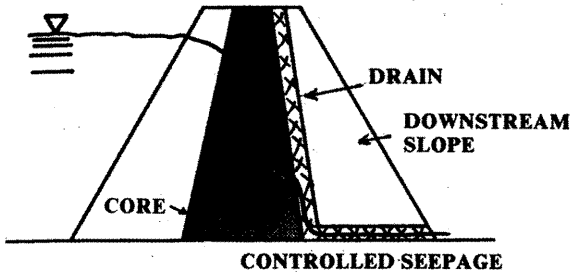

FIGURE 3.4-7  
ZONED WITH DRAIN

The drain is a method of **controlling** the seepage of water through a dam. Water entering the drain flows freely through the drain and exits safely beyond the dam without wetting the material in the downstream zone.

Most older dams in Colorado are **homogeneous**. A method used to control seepage on some of the older dams was to stop the water at the source, by placement of a barrier of steel or concrete on the upstream face of the dam.

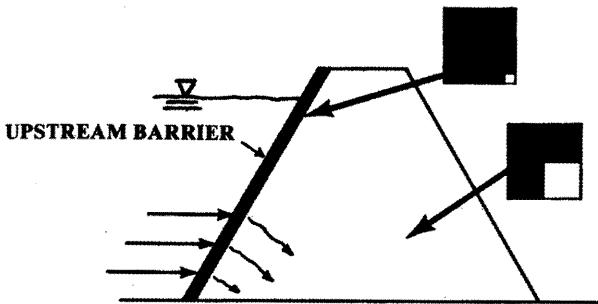

FIGURE 3.4-8  
UPSTREAM BARRIER

3.4-2 FOUNDATION CUTOFF

Extending the barrier into the foundation, as shown below at Point A, also helps to control the flow of water through the foundation.

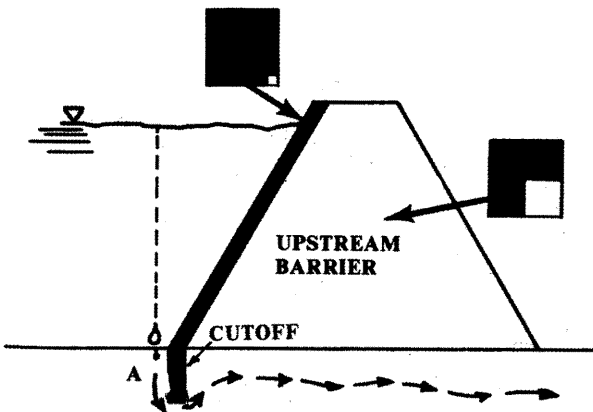

FIGURE 3.4-9  
BARRIER EXTENDED INTO FOUNDATION

Without the extension (cutoff), water will go under the barrier and exit at the base of the embankment, defeating the purpose of the barrier.

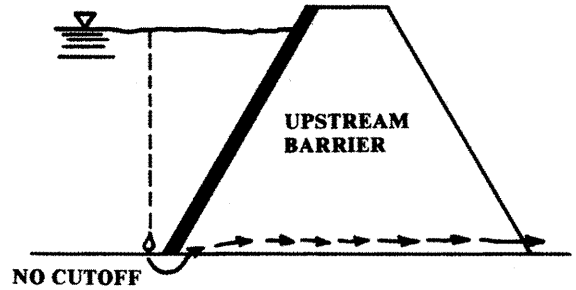
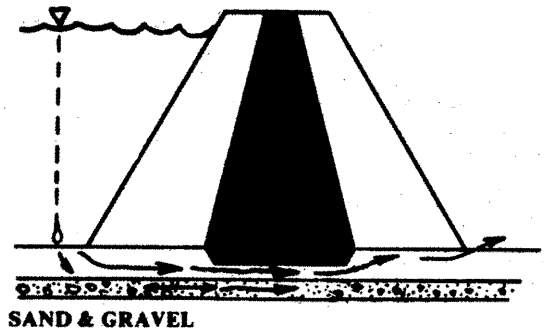

FIGURE 3.4-10  
FLOW PATH IN COARSE MATERIAL WITHOUT CUTOFF

Extending the barrier into the foundation to control the flow of water under the dam is important.

If the foundation has low resistance to the flow of water, for instance, through fractured rock or a sand layer, the most effective means of reducing the flow of water through the foundation is a cutoff. Often the core is extended into the foundation by digging a trench along the length of the dam and filling it with the flow-resistant material. The sketch below shows how the cutoff trench controls the flow of water through the foundation. Controlling flow is necessary to prevent excessive loss of reservoir water and assure the stability of the foundation.



a. Cutoff Too Shallow

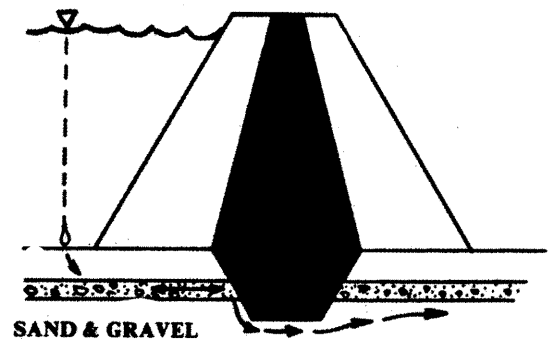

b. Effective Cutoff

FIGURE 3.4-11  
CUTOFF TRENCH

Many of the principles of earth dams also apply to the behavior of rockfill dams.

### 3.5 ROCKFILL DAMS

Most rockfill dams are similar in shape to earth dams. The difference is that rock fragments make up the primary material used for construction. The choice of constructing a rockfill dam versus constructing an earth dam is usually based on availability of materials. The sketch below illustrates one configuration of a rockfill dam.

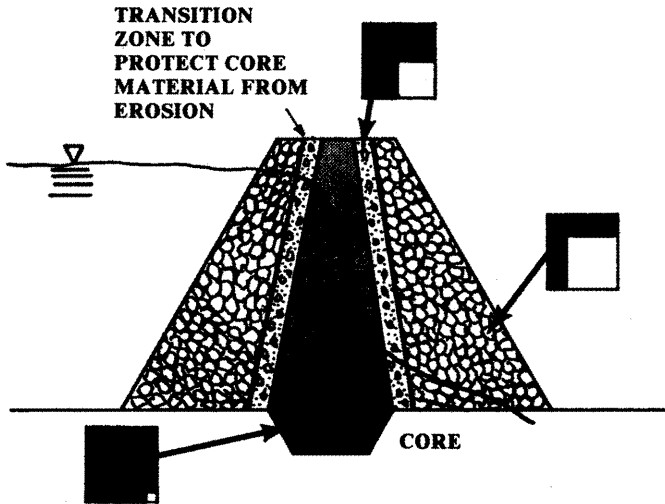

FIGURE 3.5-1  
TYPICAL ROCKFILL CROSS SECTION

Because rock fragments alone would leave large openings for seepage flow, a central core, like that in the zoned earth dam, is required. Also, note that the core extends into the foundation to help control the flow of water under the dam. A transition zone is usually necessary to protect the core from erosion. The transition zone is designed to keep the fine-grained core materials from being washed into or through the rockfill.

### 3.6 CONCRETE DAMS

Concrete dams are the least common types in Colorado. Concrete is probably the most durable material for building dams and has a very high resistance to seepage.

A concrete dam is unique in that it directly transfers some of the pressures created by the stored water to the foundation and abutments. A concrete dam, therefore, is very dependent upon the ability of the foundation and abutments to hold the dam in place.

There are two basic designs for concrete dams: gravity and arch. The sketches below show how the two are tied into the foundation and abutments.

#### 3.6-1 CONCRETE GRAVITY DAM

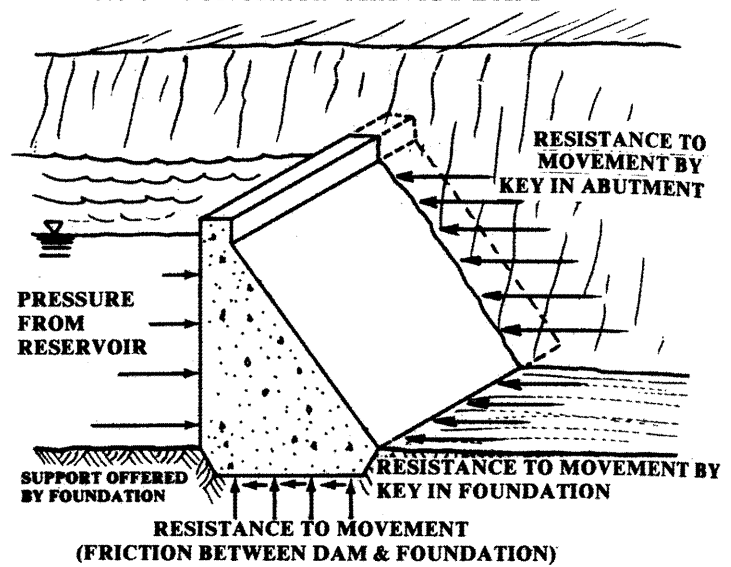

FIGURE 3.6-1  
CONCRETE GRAVITY DAM

Without a proper key or tie into the abutments and foundation, and without enough weight, a gravity dam could tip over or slide downstream as shown below.

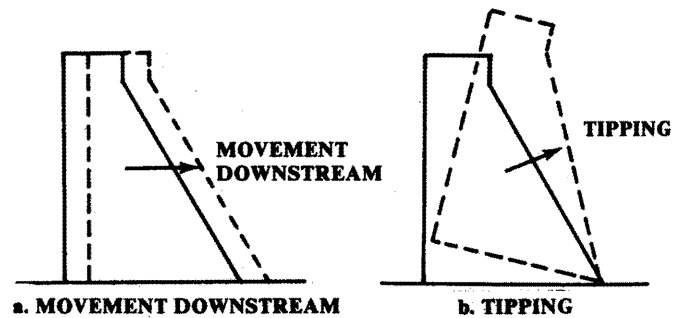

FIGURE 3.6-2  
GRAVITY DAM MUST RESIST RESERVOIR LOADS

The choice of a concrete gravity dam over other types is based on the available material and the site conditions.

#### 3.6-2 CONCRETE ARCH DAM

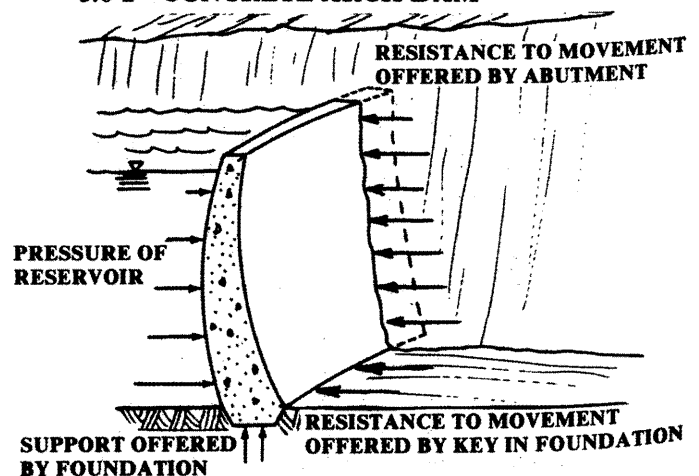

FIGURE 3.6-3 — CONCRETE ARCH DAM

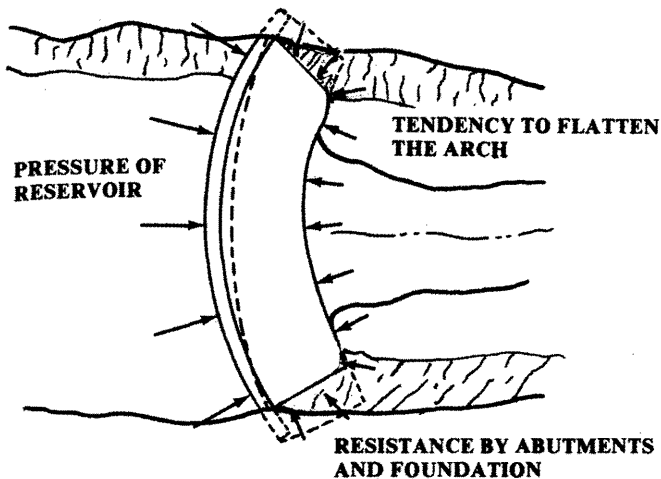

FIGURE 3.6-4  
OVERHEAD VIEW OF ARCH DAM

The view above shows how the pressures from the reservoir tend to flatten the arch and how the action is resisted by the abutments and foundation. The failure of an arch dam can occur if one abutment releases its support.

A concrete arch dam usually requires less material than a concrete gravity dam. But the arching action requires a very suitable foundation and abutment area.

### 3.6-3 SPECIAL FOUNDATION TREATMENT

Like earth or rockfill dams, a concrete dam has special provision for controlling seepage under the dam. The most common method is pressure grouting a line of holes into the foundation and abutments before the dam is constructed. The cement grout will fill most voids or fractures in the rock. The sketch below illustrates the difference between the flow paths with and without grout treatment.

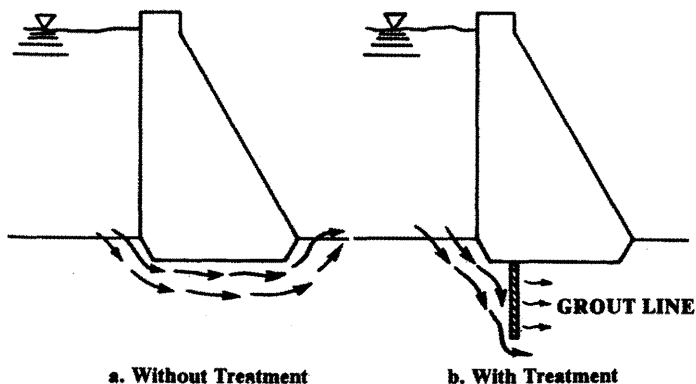

FIGURE 3.6-5  
GROUTED CUTOFF

This method is not limited to concrete dams, but can also be used to control seepage under an earth or rockfill dam.

If a dam is designed and constructed to perform safely the functions of (1) holding back water, (2) resisting movement, and (3) maintaining shape, it can have a long, successful life span.

### 3.7 SPILLWAY

A spillway is required for a dam to allow excessive inflows to pass the reservoir site without overtopping the dam. The spillway may be in natural terrain, excavated in rock, or constructed of concrete.

A spillway can be located on either abutment or constructed as part of the dam. Sometimes a natural drainage channel in the reservoir is used to carry floodwater safely around the dam. The location is selected based on the topography, size of expected storm, and economics.

The adequacy of an existing spillway requires evaluation by a professional engineer and is beyond the scope of this manual. The owner can, however, inspect the spillway for damage and deterioration. Chapter 10 lists the signs to look for and indicates whether the damage requires maintenance or the attention of an engineer.

### 3.8 OUTLET SYSTEM

The primary purpose of an outlet system is to provide for controlled release of the water from the reservoir behind the dam. Upon demand, the outlet system releases water downstream for irrigation or other uses. The system is also used to lower the reservoir in an emergency or for maintenance and repair of the dam and appurtenant structures.

The size of the outlet system is determined by the rate of the demand for use of the water. The adequacy of the outlet requires evaluation by a professional engineer. The owner should, however, inspect the outlet system for damage and hazardous conditions. Chapter 9 presents a list of important signs the owner should look for to identify situations which may endanger his dam.

### 3.9 SUMMARY

This chapter applied the principles of Chapter 2 in explaining the behavior of dams and how the design fulfills the purpose of **holding back water**.

The remainder of the manual specifically addresses the inspection and maintenance of earth dams. However, the similarities between the different types of dams should enable the owner to apply his knowledge to inspection and maintenance of other types of dams.



#### 4.1 WHAT AND WHY SO IMPORTANT

Visual inspection performed on a regular basis is the most economical aid a dam owner can use to assure the safety and long life of the structure. Visual inspection is a straightforward procedure that allows any properly trained person to make an accurate assessment of a dam's condition. The inspection involves careful examination of the surface on all parts of the structure. The equipment required is not expensive and the inspection usually can be completed in less than one day.

The essentials of the inspection will be discussed after a look at useful inspection equipment and inspection findings that must be recorded.

#### 4.2 INSPECTION EQUIPMENT AND ITS USE

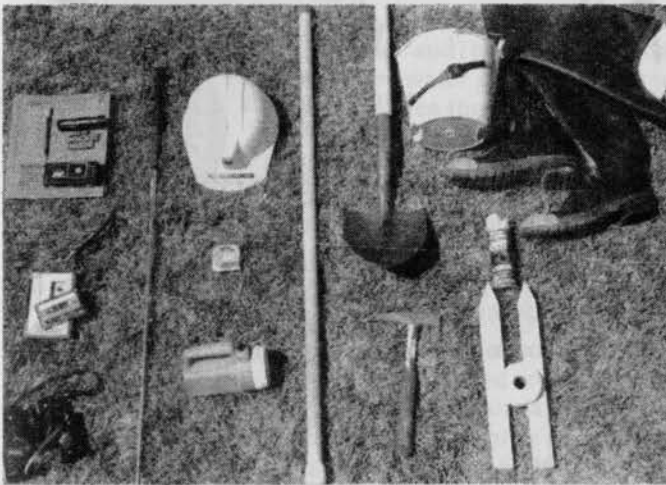

FIGURE 4.2-1 INSPECTION EQUIPMENT — Notebook, pencil, hand-level, camera, tape recorder and tape, binoculars, probe, hard hat, pocket tape, flashlight, bonker, shovel, rock hammer, bucket and stopwatch, bug spray, flagging tape and stakes, waterproof boots.

**INSPECTION CHECK LIST** — Serves as a reminder to inspect for all important conditions. An example is presented at the end of this chapter.

**NOTEBOOK AND PENCIL** — It is very important to write down observations at the time they are made. This reduces mistakes and the need to return to the area to refresh the inspector's memory.

**TAPE RECORDER** — A small portable tape recorder can also be used effectively to make a record of field observations.

**CAMERA** — Photographs provide a reliable record of observed field conditions. They can be valuable in comparing past and present configurations. An inexpensive model usually takes pictures good enough for inspection records.

**HAND LEVEL** — This is needed to locate accurately areas of interest and to determine embankment heights and slope.

**PROBE** — A probe can provide information on conditions below the surface, such as the depth and softness of a saturated area. Also, by observing moisture brought up on the probe's surface, the inspector can decide whether an area is saturated or simply moist. An effective and inexpensive probe can be made by removing the head from a golf club.

**HARD HAT** — A hard hat is recommended for inspecting large outlets or working in construction areas.

**POCKET TAPE** — Many descriptions are not accurate enough when estimated or paced. The pocket tape provides accurate measurements which allow meaningful comparisons to be made.

**FLASHLIGHT** — The interior of an outlet in a small dam can often be inspected adequately without crawling through by using a good flashlight or fluorescent lantern.

**SHOVEL** — A long-handled shovel is useful in clearing drain outfalls, removing debris, locating monitoring points, and killing snakes and rodents.

**ROCK HAMMER** — Questionable-looking riprap or concrete can be checked for soundness with a rock hammer. Care must be taken not to break through thin spots or cause unnecessary damage.

**BONKER** — The condition of support material behind concrete or asphalt faced dams cannot be determined by observing the surface of facing. By firmly tapping the surface of the facing material, conditions below can be determined by the sound produced when the material is tapped. Facing material fully supported by fill material produces a "click" or "bink" sound, while facing material that is over a void or hole in the facing produces a "clonk" or "bonk" sound. The bonker can be made of 1¼-inch hard wood dowel with a metal tip firmly affixed to the tapping end. A rubber shoe like those on some furniture legs is recommended for the other end to allow the bonker to be used as a walking aid on steep, slippery slopes.

**BINOCULARS** — These are useful for inspecting limited access areas especially on concrete dams.

**GALLON CONTAINER AND TIMER** — These are used to make accurate measurements of leakage flows. Establishing the time it takes the seepage flow to fill the gallon bucket enables the inspector to calculate the number of gallons per minute. Various container sizes may be required, depending on the flow rates.

**STAKES AND FLAGGING TAPE** — These are used to mark areas requiring future attention and to stake the limits of existing conditions, such as cracks and wet areas, to allow future comparison.

**WATERTIGHT BOOTS** — These are often required when inspecting various areas of the dam site where standing water is present.

**BUG REPELLENT** — Biting bugs can gravely reduce the efficiency and effectiveness of the inspector and so on his disposition.

**SNAKE BITE KIT** — In areas where rattlesnakes or other poisonous snakes might be present, it is recommended that a snake bite kit be kept handy.

#### 4.3 INSPECTION OBSERVATIONS THAT MUST BE RECORDED

The visual inspection is performed to allow the dam owner to be knowledgeable about the condition of his dam and to allow any problems to be identified when they **begin** to develop. An accurate and detailed description of the condition of the dam observed during each inspection will make possible meaningful comparisons of conditions.

All measurements and descriptive details that are required to portray an accurate picture of the dam's current condition must be recorded. This information falls into three categories:

**LOCATION** — The location of any questionable area or condition must be accurately described to allow that area or condition to be properly evaluated. The location along the length of the dam, as well as height above the toe or distance down from the dam's crest, must be established and recorded. The same applies to conditions associated with the outlet or spillway.

**EXTENT OF AREA** — The length, width, and depth or height of any area where a suspected problem is found.

**DESCRIPTIVE DETAIL** — A brief yet detailed description of a condition or observation must be given. Some description items are:

**QUANTITY OF DRAIN OUTFLOWS**

**QUANTITY OF SEEPAGE FROM POINT AND AREA SOURCES**

**COLOR OR QUANTITY OF SEDIMENT IN WATER**

**DEPTH OF DETERIORATION IN CONCRETE LENGTH, DISPLACEMENT, AND DEPTH OF CRACKS**

**IS AREA MOIST, WET, OR SATURATED?**

**IS PROTECTIVE COVER ADEQUATE?**

**IS SURFACE DRAINAGE ADEQUATE?**

**DO SLOPES LOOK TOO STEEP?**

**DOES DETERIORATION APPEAR TO BE RAPID OR SLOW?**

**HAVE CONDITIONS CHANGED?**

The above listing of inspection findings that must be recorded is not meant to be a complete list but is to serve as a guide. Keep in mind that if the inspector thinks a condition has changed since the last inspection he must make note of it. He should also take a photo and put it into his file, carefully noting the date and writing a description of the scene shown on the photo.

#### 4.4 SIGHTING TECHNIQUE

A sighting technique similar to that used when selecting straight pieces of lumber can be useful in identifying misalignments as well as high or low areas along a surface. The technique is illustrated.

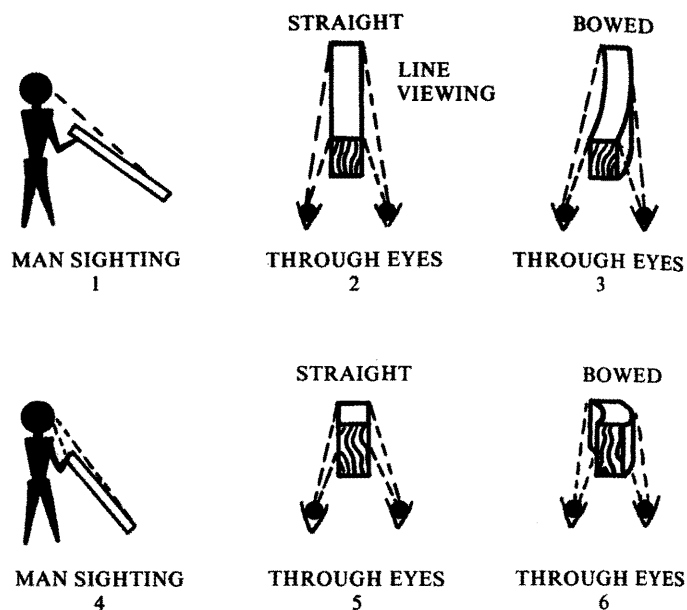

FIGURE 4.4-1 SIGHTING TECHNIQUE

When checking alignment on parts of the dam center eyes along the line being viewed. Sighting along the line, move from side to side a little to view the line from several angles.

For example, sighting along the edge of the crest:

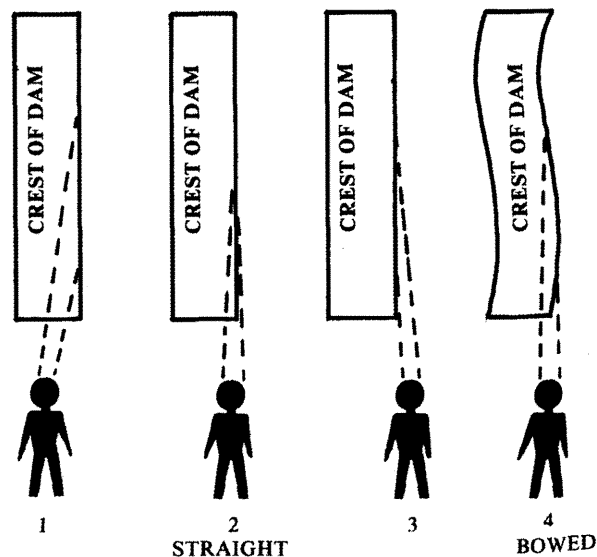

FIGURE 4.4-2 SIGHTING ALONG CREST

Looking through a pair of binoculars will help to make changes more obvious.

#### 4.5 SOME TYPICAL PROBLEMS

Various conditions are seen during the inspection that may indicate a developing problem. A few of these will be discussed here to demonstrate what the inspector needs to do and how the equipment should be helpful.

4.5-1 ACCESS

LOCKED

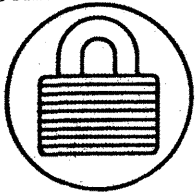

Access to the dam site as well as to operating equipment and monitoring devices must be available. Lost keys should be replaced and broken locks repaired or replaced.

OBSTRUCTED



Areas that require inspection can be obstructed by tumbleweeds, trash, or rock slides. These obstructions need to be burned or shoveled out. A lot of snakes in an area can make the area unsafe. If the dam site cannot be inspected when the snakes are inactive, special safety precautions are recommended.

INUNDATED

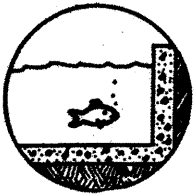

Provisions must be made to shut off outlet flows and/or pump out low areas where water ponds in order to inspect the area thoroughly. When a worsening condition is suspected, the inspection must be done immediately in spite of water user needs.

4.5-2 UNEVEN SURFACES

SWALE OR BOWS



Swale and bows are depressions and bulges that are evenly distributed over a large area. A swale is also referred to as a dished area. This subtle type of change from a continuous surface can be indicative of a serious structural problem. **Sighting** can be used to identify the condition. Dished or bowed areas should be closely examined for any developing cracking pattern. The location of the misaligned area along the dam's length,

plus the size of area affected and estimated amount of deviation, or offset should be recorded. If the condition will show up on a photograph, a picture should be taken.

BULGE AND DEPRESSION



A bulge or depression is a localized condition. This should be closely inspected for adjacent cracking patterns. Probing should be done to find out if any excessive moisture or soft material is present.

4.5-3 CRACKS

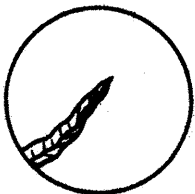

Cracks of various sizes can be found in earth, concrete, asphalt, and steel portions of the dam. They always require close up observation and should usually be recorded. Cracks in earthwork should be investigated with the probe to determine their depth and whether they may be associated with excess moisture. Measurements should be made to determine the width, depth, and displacement. Normally, cracks in earth less than 10 feet

long and 1/2 inch wide should be measured and recorded. Larger cracks or cracking systems should be monitored. (See Chapter 12.) The ends of cracks or cracking systems should be marked with a pin or stake to allow measurement of any growth.

4.5-4 DISPLACEMENTS OR SLIDES

SCARP

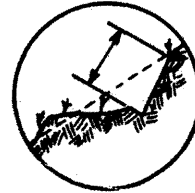

Side View

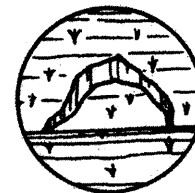

Front View

Displacements or slides often indicate a structural problem. The dam can no longer maintain its shape. These areas should be thoroughly examined for surrounding cracks, especially uphill from the displacement or scarp. The entire area should be probed to determine the condition of the surface materials. The hand level should be used to locate accurately the top of the scarp (x). This will allow progressive deterioration to be detected. The base width should be measured or accurately paced. Any seepage flows should be located and the quantity measured or estimated. It is extremely important to note if the seepage water is muddy or if it is carrying off soil material. It is helpful if the type of soil can be identified, i.e., sand, clay, etc.

4.5-5 LEAKAGE AREAS

CONCENTRATED FLOW

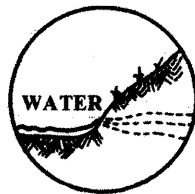

Side View

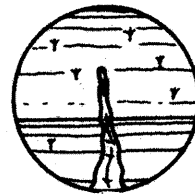

Front View

Exact location and quantity of flow must be determined as accurately as possible. The water should be carefully examined to see if it is carrying embankment materials. A jar sample is recommended. At a minimum, the inspector should allow the water to run over a cupped hand for 15 seconds, then see if any soil grains have been deposited. Water that looks very clear can be carrying quite a few soil particles. The area around the exit point should be probed to determine if a saturated area surrounds the leak. Quantity measurements should be begun to allow accurate comparison. This will allow increases to be detected and recorded.

SATURATED AREAS



Side View

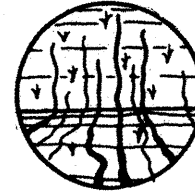

Front View

Location and extent of wet or saturated areas must be recorded along with any measurable flow quantities. These areas are usually "squishy" when walked on. There can be a visible flow on the surface. These areas should be probed to determine how soft the material has become. If very soft, it may lead to local slides. The presence of vegetation which flourishes in wet places can indicate a saturated area.

**DRAIN OUTFALLS**

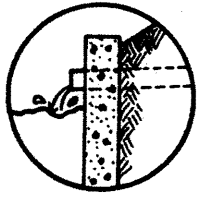

Drain outfalls should be examined to make sure there are no obstructions in the pipe. The flashlight and probe are useful here. Flow quantities require accurate measurement. Bucket measurements or a "V" notch weir are usually used for these measurements. Outflows should be examined for soil particles.

**LEAKAGE AT ABUTMENT CONTACT**



The entire abutment area downstream from the dam should be carefully inspected for leakage. Special attention must be given to the contact between the manmade embankment and the natural terrain. Leakage at the contact can cause erosion of embankment material.

**4.5-6 SLOPE PROTECTION**

**DISPLACED RIPRAP**



Riprap is designed to protect the earthen embankment material against wave action. When deteriorated areas are discovered, the extent and threat to the embankment materials need to be determined. Photos should be taken.

UNPROTECTED EMBANKMENT

**RIPRAP BREAKDOWN**

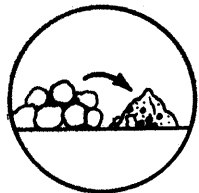

When the rock used for riprap is breaking down, the extent of the damage must be assessed to determine if the embankment is threatened. The rock hammer can be used to see how sound and durable the rock seems to be.

**HOLES OR CRACKS IN UPSTREAM FACING VOID**

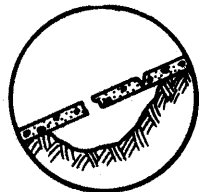

Holes or cracks in the upstream facing can allow underlying embankment material to be pumped out by wave action. The entire facing must be examined for small openings, especially along construction joints.

**UNSEEN VOIDS UNDER UPSTREAM FACING**

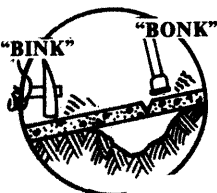

Voids under upstream facings can allow the facing over the void to collapse, jeopardizing the safety of the dam. To check for these undetected voids, the bonker is used. Bonkie-sounding areas should be flagged for further investigation.

**DETERIORATED AREAS IN FACINGS**

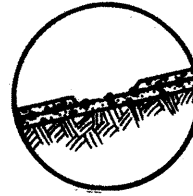

Deteriorated or spalled areas must be explored with the rock hammer to determine if immediate repairs are required. Even if the remaining material seems sound, concrete must be repaired if the reinforcing is exposed.

**DETERIORATION IN OUTLET OR SPILLWAY CHANNELS**



Channel protection displaced by high velocity flows can lead to rapid deterioration in the unprotected area. Extent of unprotected area and rate of deterioration should be determined. The probe and flagging stakes can be useful here.

**RIPRAP MISSING**

**4.5-7 CONCRETE STRUCTURES**

**DETERIORATION**

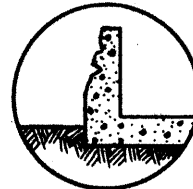

All deteriorated areas must be carefully examined and checked with a rock hammer. The objective is to determine if the deterioration affects the function of the structure. Location and extent of deterioration should be noted and photos taken.

**DISPLACEMENT**

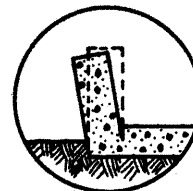

Displacements can be found by sighting. All apparent displacements should be recorded to allow a worsening condition to be verified during future inspections. Cracks must be explored to see if reinforcing is exposed, since rapid deterioration of reinforcing can lead to failure of the structure. Photos should be taken.

**4.5-8 STEEL — METAL**

**CRACKS, HOLES DETERIORATED AREAS**

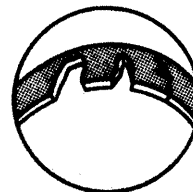

Location and extent of cracks, holes, or deteriorated areas must be recorded. These areas may require scraping clean to allow an assessment of the extent of the deterioration. Photos should be taken.

**4.6 INSPECTION PROCEDURE**

To obtain the best results and allow for consistent recording of inspection findings, it is best to follow a specific sequence when making the inspection. Before discussing the sequence a few ideas on technique will be discussed.

## COVERAGE

The inspection is conducted by walking along and over the dam as many times as is required to see every square foot. From any given spot a person can usually gain a detailed view for a distance of 10 to 30 feet in each direction, depending on the smoothness of the surface or the type of material on that surface, i.e., grass, concrete, riprap, brush.

An inspector can view from 10 ft. to 30 ft., depending on cover.



FIGURE 4.5-1 SIGHT DISTANCE

To cover expansive surfaces properly, several walkings are required.

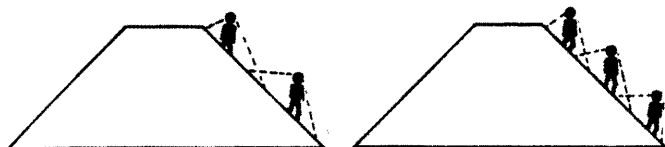
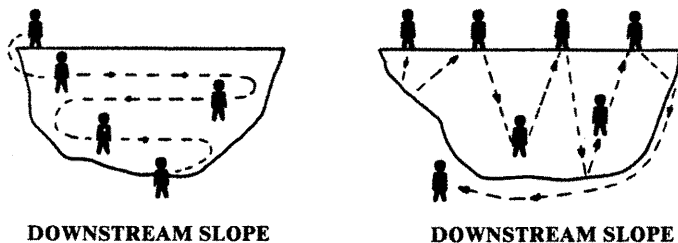

FIGURE 4.5-2 SUCCESSIVE PASSES

Adequate coverage can be achieved using a parallel or zigzag path.



DOWNSTREAM SLOPE

DOWNSTREAM SLOPE

FIGURE 4.5-3 COVERAGE PATH

On the downstream slope a zigzag path is recommended to assure that any cracking is detected.

**STOP AND LOOK** — At several points on the slope, the inspector should stop and look around for 360° to check alignments and to be sure he has not overlooked some important feature of the slope.

## SEQUENCE

A productive sequence of inspection that has been used with favorable results is:

UPSTREAM SLOPE

CREST

DOWNSTREAM SLOPE

ANY SEEPAGE AREAS

OUTLET

SPILLWAY

Following a specific sequence will lessen the chance of an important condition being overlooked. Reporting inspection results in the same sequence is recommended to allow consistent records.

## 4.7 RECORD KEEPING

A dated report should be filled out for each periodic inspection. This report should be filed along with any pictures that were taken. The pictures should be dated to keep them identified with the correct inspection date. Inspection observations can be recorded on the report format at the end of this chapter.

Two items are especially important to note during the inspection to allow the observations to be evaluated properly.

**THE INSPECTOR MUST BE CAREFUL TO RECORD:**

1. GAGE ROD READING
2. WEATHER CONDITIONS THAT INFLUENCE OBSERVATIONS ESPECIALLY RECENT RAINS, EXTENDED DRY SPELLS, SNOW COVER, ETC.

In addition to the inspection observations any monitoring measurements should be recorded in a useful format and made a part of the inspection record.

## 4.8 EVALUATION OF INSPECTION OBSERVATIONS

The record of periodic inspection observations is used to develop a mental picture of the dam's performance. The accurate measurements pay off here because small changes, which would go undetected if simply looked at, will show a pattern or trend and the owner can begin addressing any potential problem before it becomes a threat to the dam.

Immediately following the inspection the observations should be compared with previous records to see if there is any condition, reading, or trend that may indicate a developing problem. When a significant change is seen, design drawings for the dam should be examined carefully to see if an obvious reason for the change can be found. If a questionable change or trend is noted, the inspector should not hide it. *He should contact one of the professional engineers in the Inspection Unit of the State Engineer's Dam Safety Branch or his own consulting engineer.* The engineer will determine if any action, such as increased monitoring or detailed investigation of the condition, is required.

This cooperative action will help assure the safety; safe operation; and long, useful life of the dam.

## 4.9 SUGGESTED PLANNING

Getting the most out of an inspection requires some preparatory work:

1. The previous inspection report should be reviewed to note any areas which will require special attention.
2. If the purpose of the inspection is to re-evaluate questionable conditions discovered during the last inspection, available design or construction drawings should be examined to see if they might explain the situation.

3. Equipment should be assembled.
4. Entry and meeting arrangements for persons accompanying the inspector should be made.
5. Provisions for outlet shut off and dewatering, if required, should be made.
6. A good weather day, if possible, should be chosen.

#### 4.10 CRUCIAL INSPECTION TIMES

There are a few special times when an inspection is recommended:

1. Prior to a predicted major rainstorm or heavy snow melt: check spillway, outlet channel, and riprap.
2. During or after severe rainstorm: check spillway, spillway and outlet channel, and riprap.
3. Severe windstorm: check riprap performance during a storm and after it has subsided.
4. Earthquake in area: make complete inspection right after the event and weekly inspections for the next six weeks to detect any delayed effects.
5. First filling: a regular schedule of frequent complete inspections must be scheduled during the period the dam is being filled for the first time. This activity is to assure that the design and site conditions are serving as predicted. The inspection and filling schedule are prescribed by the design engineer and approved by the State Engineer.

#### 4.11 ADDITIONAL CONSIDERATIONS

**END OF CONSTRUCTION** — The end of construction condition is very important. Surfaces that are shown as plane or uniform surfaces on the drawings must be as close as possible to a plane surface at the end of construction. An uneven surface prevents accurate observation of change in that surface.

**KEEP THE DAM CLEAR OF OVERGROWTH** — Overgrown areas of the dam are difficult to inspect and do not get adequately inspected. All portions of the dam and an area extending a minimum of 20 feet beyond the downstream toe should be kept clear of obscuring growth. Protective grass cover should be encouraged.

#### 4.12 SUMMARY

This chapter briefly outlined the general procedure for visual inspection of a dam. **Visual inspection is the most economical aid the dam owner can use to assure the safety and long life of his dam.**

In the chapters that follow, specific problems occurring on various portions of the dam are discussed.

#### 4.13 INSPECTION REPORT AND FORMS

Two different inspection report forms are included. These forms can be reproduced and used or may serve as an aid for the owner in developing his own form.

# DAM INSPECTION REPORT

Name of Dam \_\_\_\_\_ C: \_\_\_\_\_ Date: \_\_\_\_\_ I.D. \_\_\_\_\_ W.D. \_\_\_\_\_

Type of Dam (circle): EARTHFILL, ROCKFILL, CONCRETE, OTHER \_\_\_\_\_

Estimate Actual Capacity: \_\_\_\_\_ Estimate Surface Area: \_\_\_\_\_

Estimate Height: \_\_\_\_\_ Gage Rod Reading: \_\_\_\_\_

Waterlevel - Feet Below Spillway: \_\_\_\_\_ Estimate Spillway Width: \_\_\_\_\_

Estimate Freeboard (Spillway to Top of Dam): \_\_\_\_\_

Use: IRRIGATION, MUNICIPAL, OTHER \_\_\_\_\_

**DIRECTIONS:** Mark an "X" in the Yes or No column and circle the word or phrase which applies.

	Yes	No
1. Are the roads to the dam adequate to allow ACCESS BY EMERGENCY EQUIPMENT and TRAVEL ACROSS THE DAM (i. e., TRUCKS, AMBULANCES)?	<input type="checkbox"/>	<input type="checkbox"/>
2. Is there DEBRIS, TREES, or BRUSH on the upstream slope that prevent seeing the entire surface of the slope?	<input type="checkbox"/>	<input type="checkbox"/>
3. Are there TREES or BRUSH on the CREST, or DOWNSTREAM SLOPE that prevent seeing the entire surface?	<input type="checkbox"/>	<input type="checkbox"/>
4. Are there CRACKS, SLIDES, SLUMPS, BOILS, SETTLEMENT or OTHER on the UPSTREAM SLOPE, CREST, or DOWNSTREAM SLOPE?	<input type="checkbox"/>	<input type="checkbox"/>
5. Are there RODENT HOLES or ERODED GULLIES on the UPSTREAM or DOWNSTREAM SLOPE?	<input type="checkbox"/>	<input type="checkbox"/>
6. Is the upstream slope eroded from wave action?	<input type="checkbox"/>	<input type="checkbox"/>
is there FLOWING WATER or LARGE BOGGY SPOTS at the toe of the dam?	<input type="checkbox"/>	<input type="checkbox"/>
8. Are there FLOWS OF WATER or WET SPOTS above the toe of the dam?	<input type="checkbox"/>	<input type="checkbox"/>
9. Is the riprap DISPLACED or BROKEN DOWN or MISSING?	<input type="checkbox"/>	<input type="checkbox"/>
10. Are there toe drains?	<input type="checkbox"/>	<input type="checkbox"/>
11. Is the water from the TOE DRAINS or LEAKS found to be MUDDY or SANDY?	<input type="checkbox"/>	<input type="checkbox"/>
12. Are any of the concrete portions excessively CRACKED or SPALLED?	<input type="checkbox"/>	<input type="checkbox"/>
13. Is the OUTLET CONTROL or GATE found to be STUCK, BROKEN, or EXCESSIVELY CORRODED?	<input type="checkbox"/>	<input type="checkbox"/>
14. Is the outlet control easy to get to?	<input type="checkbox"/>	<input type="checkbox"/>
15. Is released water UNDERCUTTING THE OUTLET or ERODING THE EMBANKMENT?	<input type="checkbox"/>	<input type="checkbox"/>
16. Does the spillway channel show significant EROSION, BACKCUTTING or DETERIORATION?	<input type="checkbox"/>	<input type="checkbox"/>
17. Is the spillway obstructed with FLASHBOARDS, TREES, DEBRIS, BRUSH or OTHER ?	<input type="checkbox"/>	<input type="checkbox"/>
18. Is there evidence that the dam has been overtopped?	<input type="checkbox"/>	<input type="checkbox"/>
19. Are spillway WALLS, FLOOR, CONTROL SECTION, and ENERGY DISSIPATOR in POOR condition?	<input type="checkbox"/>	<input type="checkbox"/>
20. Is the outlet pipe BLOCKED, BROKEN, or EXCESSIVELY CORRODED or OTHER ?	<input type="checkbox"/>	<input type="checkbox"/>
21. Is the reservoir usually full YEAR ROUND, OVER 1/2 OF YEAR, or LESS THAN 1/2 OF YEAR?	<input type="checkbox"/>	<input type="checkbox"/>
22. Should this dam be promptly inspected by a field engineer? from the State Engineer's offices?	<input type="checkbox"/>	<input type="checkbox"/>

23. Additional Comments: \_\_\_\_\_

Inspected By: \_\_\_\_\_





## DAM INSPECTION REPORT FORM CHECK LIST

### AREAS OF DAM

### ITEMS TO ADDRESS

UPSTREAM FACE  
CREST  
DOWNSTREAM FACE

PROTECTION  
UNIFORMITY  
DISPLACEMENTS  
CRACKING  
EROSION

RODENT ACTIVITY  
OBSCURING GROWTH  
WETNESS  
CHANGES IN CONDITION

SEEPAGE

LOCATION  
CHARACTERISTICS OF AREA  
(i.e. SOFT, BOGGY, FIRM)  
QUANTITY  
TRANSPORTED OR  
DEPOSITED MATERIAL  
EFFLUENT QUANTITY AND  
COLOR

EXTENT OF AREA  
CONCENTRATED FLOWS  
BOILS  
COLOR  
TOE DRAIN

OUTLET

DETERIORATION  
ACCESSIBILITY  
CONDUIT LEAKAGE  
AROUND CONDUIT

OPERABILITY  
CONDITION  
GATE LEAKAGE  
UNDERCUTTING

SPILLWAY

DETERIORATION  
CONDITION OF CONTROL  
SECTION  
CHANNEL PROTECTION

CHANNEL OBSTRUCTIONS  
EROSION OR BACK  
CUTTING IN CHANNEL

**5.1 INTRODUCTION**

An earth dam is judged to be effective or ineffective based on its ability to form a water barrier. In Chapter 2, we learned how different soils can help form a barrier. In Chapter 3, various configurations of an earth embankment were shown along with the paths water will take through the embankment. Techniques and procedures for inspecting the dam were presented in Chapter 4.

Seepage is discussed before any other portion of the dam because detailed observation of the location and extent of seepage water appearing on the ground surface can provide accurate information about a dam's performance and condition. By correctly interpreting seepage patterns, the owner can identify and correct many potential problems before they threaten the safety of the dam. Every area that is producing or has produced seepage must be identified and continually monitored. A record of the extent of flow areas and flow quantities must be kept.

**5.2 ITEMS OF PARTICULAR CONCERN**

Excessive seepage can jeopardize the dam in two ways:

**HIGH VELOCITY FLOWS THROUGH THE DAM CAN SET UP PROGRESSIVE EROSION OF THE EMBANKMENT MATERIALS, LEADING TO FAILURE OF THE DAM.**

**SATURATED AREAS OF THE EMBANKMENT OR ABUTMENT CAN MOVE IN MASSIVE SLIDES AND LEAD TO FAILURE OF THE DAM.**

Seepage in any area on or near the dam can be dangerous. All seepage should be treated as a potential problem.

**5.3 SPECIAL INSPECTION TECHNIQUES**

**SEARCH** — Since seepage can be present but not seen, an intensive search must be made of all downstream areas where seepage water might emerge. Even in short grass cover, the seepage may not be seen and must be walked over to be found.

**PROBING** — Probing can help identify the limits of saturated areas, the degree of wetness or saturation, and the depth of softened surface materials.

**DIFFERENCE IN VEGETATION** — Vegetative growth in moist or saturated areas is often of a different type than surrounding areas or has a deeper green color or more lush nature than drier neighboring areas. When a difference is noted the greener area must be carefully examined for seepage.

**TRACKS** — The depth of footprints the inspector leaves in wet or saturated material shows how soft surface materials have become.

**5.4 FIELD CONDITIONS ENCOUNTERED**

The following table presents most of the harmful conditions caused by seepage that will be found at an actual dam site. For each condition the cause, harm done, and required corrective actions are given. Any of the conditions that require assessment by an engineer should be reported to the State's Dam Safety Engineer at the time it is discovered.

**5.5 SUMMARY**

Careful inspection for and accurate assessment of seepage can help the dam owner identify potential problems before they threaten the safety of the dam.

Regular inspection of the dam can identify any changes in previously noted conditions that may indicate a safety problem.

Quick reaction to conditions requiring attention will promote the safety and long life of the dam and possibly prevent costly repairs.

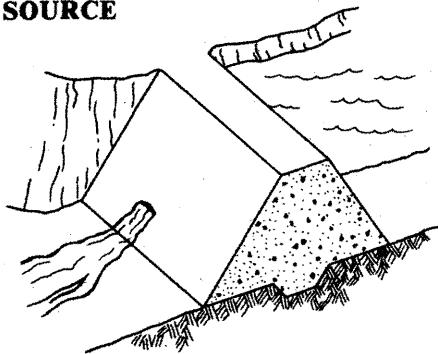
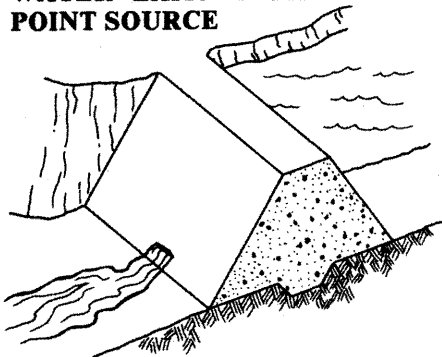
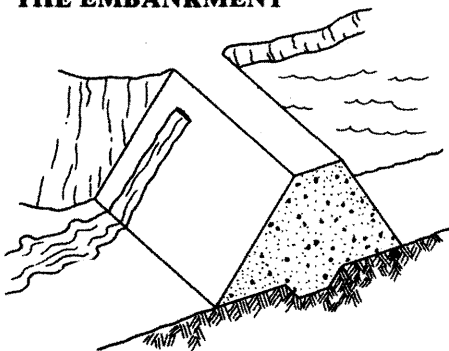
**PROBLEM****5.4-1****EXCESSIVE MUDDY WATER EXITING FROM A POINT SOURCE****5.4-2****EXCESSIVE AMOUNT OF WATER EXITING FROM A POINT SOURCE****5.4-3****WATER EXITING FROM A POINT SOURCE HIGH ON THE EMBANKMENT****CAUSES & HARM DONE****Cause:**

1. Water has created an open pathway, channel, or pipe through the dam. The water is eroding and carrying embankment material.
2. Large amounts of water have accumulated in the downstream slope. Water and embankment materials are exiting at one point. Surface agitation may be causing the muddy water.

**Harm:**

Continued flows can further erode embankment materials. This can lead to failure of the dam.

**Cause:**

Water has created an open pathway or pipe through the dam.

**Harm:**

Continued flows can further erode embankment materials. This can lead to failure of the dam.

**Cause:**

1. Rodents, frost action, or poor construction have allowed water to create an open pathway or pipe through the embankment.

**Harm:**

1. Continued flows can saturate portions of the embankment and lead to slides in the area.
2. Continued flows can further erode embankment materials and lead to failure of the dam.

**ACTION REQUIRED****Action:**

1. Begin measuring outflow quantity and establishing whether water is getting muddier, staying the same, or clearing up.
2. If quantity of flow is increasing, the water level in the reservoir should be lowered until the flow stabilizes or stops.
3. A qualified engineer should inspect the condition and recommend further actions to be taken.

**ENGINEER REQUIRED**

**Action:**

1. Begin measuring outflow quantity.
2. If quantity of flow is increasing, the water level in the reservoir may need to be lowered until the flow stabilizes or stops.
3. A qualified engineer should inspect the condition and recommend further actions to be taken.

**ENGINEER REQUIRED**

**Action:**

1. Begin measuring outflow quantity.
2. If quantity of flow is increasing, the water level in the reservoir needs to be lowered until the leak stops.
3. Search for opening on upstream side and plug it if possible.
4. A qualified engineer should immediately inspect the condition and recommend further action to be taken.

**ENGINEER REQUIRED**

## PROBLEM

5.4-4

### WATER EXITING FROM RODENT HOLES

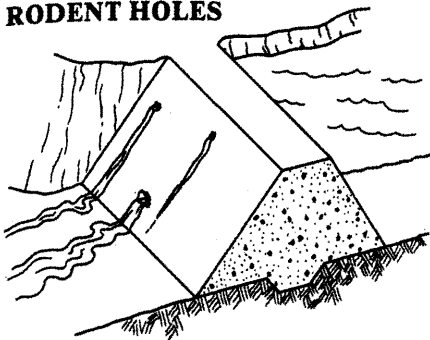

5.4-5

### STREAM OF WATER EXITING THROUGH CRACKS NEAR THE CREST

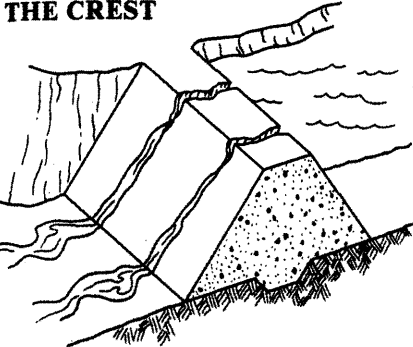

5.4-6

### SEEPAGE WATER EXITING AS A BOIL IN THE FOUNDATION

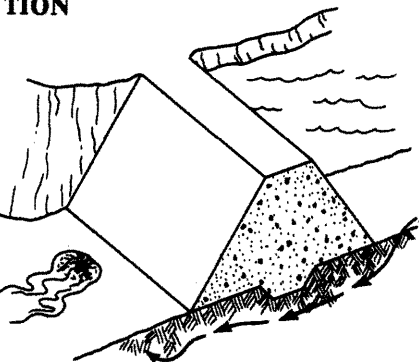

## CAUSES & HARM DONE

### Cause:

Diggings by the rodent have shortened the flow path.

### Harm:

Continued flows can further erode embankment material and lead to failure of the dam.

### Cause:

1. Severe drying has caused shrinkage of embankment material.
2. Settlement in the embankment or foundation is causing the transverse cracks.

### Harm:

Flow through the crack can cause failure of the dam.

### Cause:

Some portion of the foundation material is providing a flow path. This could be caused by a sand or gravel layer in the foundation.

### Harm:

Increased flows can lead to erosion of the foundation and failure of the dam.

## ACTION REQUIRED

### Action:

1. Locate any entrance points on the upstream slope and plug them.
2. If the quantity of flow is increasing, the water level in the reservoir needs to be lowered until the leak stops.
3. Bring a halt to the rodent activity (See Chapter 13).
4. A qualified engineer should inspect the condition and recommend further actions to be taken.

ENGINEER REQUIRED

### Action:

1. Plug the upstream side of the crack to stop the flow.
2. The water level in the reservoir should be lowered until it is below the level of the cracks.
3. A qualified engineer should inspect the condition and recommend further actions to be taken.

ENGINEER REQUIRED

### Action:

1. Examine the boil for transportation of foundation materials.
2. If soil particles are moving downstream, sandbags or earth should be used to create a dike around the boil. The pressure created by the water level within the dike may control flow velocities and temporarily prevent further erosion.
3. If erosion is becoming greater, the reservoir level should be lowered.
4. A qualified engineer should inspect the condition and recommend further actions to be taken.

ENGINEER REQUIRED

## PROBLEM

5.4-7

### SEEPAGE WATER EXITING FROM A POINT ADJACENT TO THE OUTLET

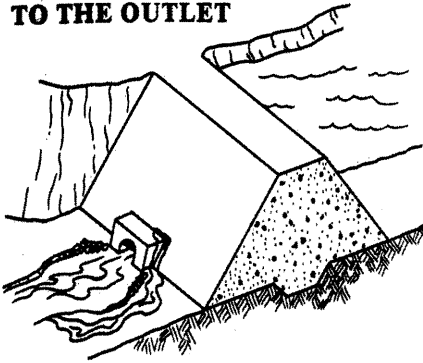

5.4-8

### LEAKAGE IN OR AROUND SPILLWAY

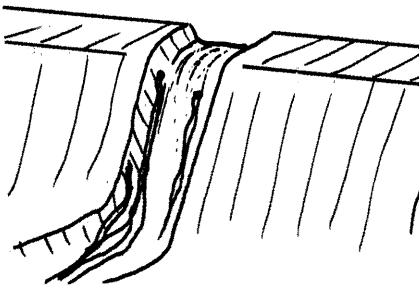

5.4-9

### SEEPAGE FROM A CONSTRUCTION JOINT OR CRACK IN CONCRETE STRUCTURE

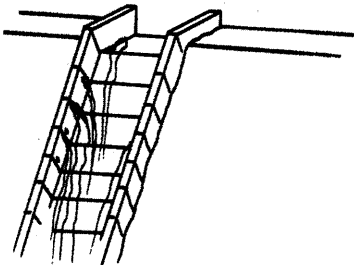

## CAUSES & HARM DONE

### Cause:

1. A break in the outlet pipe.
2. A path for flow has developed along the outside of the outlet pipe.

### Harm:

Continued flows can lead to rapid erosion of embankment materials and failure of the dam.

## ACTION REQUIRED

### Action:

1. Thoroughly investigate the area by probing and/or shoveling to see if the cause can be determined.
2. Determine if leakage water is carrying soil particles.
3. Determine quantity of flow.
4. If flow increases or is carrying embankment materials, reservoir level should be lowered until leakage stops.
5. A qualified engineer should inspect the condition and recommend further actions to be taken.

ENGINEER REQUIRED

### Cause:

1. Cracks and joints in geologic formation at spillway are permitting seepage.
2. Gravel or sand layers at spillway are permitting seepage.

### Harm:

1. Could lead to excessive loss of stored water.
2. Could lead to a progressive failure if velocities are high enough to cause erosion of natural materials.

### Action:

1. Examine exit area to see if type of material can explain leakage.
2. Measure flow quantity and check for erosion of natural materials.
3. If flow rate or amount of eroded materials increases rapidly, reservoir level should be lowered until flow stabilizes or stops.
4. A qualified engineer should inspect the condition and recommend further actions to be taken.

ENGINEER REQUIRED

### Cause:

Water is collecting behind structure because of insufficient drainage or clogged weep holes.

### Harm:

1. Can cause walls to tip in and over. Flows through concrete can lead to rapid deterioration from weathering.
2. If the spillway is located within the embankment, rapid erosion can lead to failure of the dam.

### Action:

1. Check area behind wall for puddling of surface water.
2. Check and clean as required; drain outfalls, flush lines, and weep holes.
3. If condition persists a qualified engineer should inspect the condition and recommend further actions to be taken.

ENGINEER REQUIRED

**PROBLEM**

5.4-10

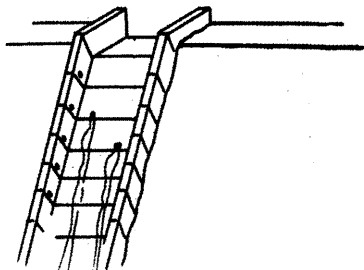
**TOO MUCH LEAKAGE FROM SPILLWAY UNDER DRAINS****CAUSES & HARM DONE****Cause:**

Drain or cutoff may have failed.

**Harm:**

1. Excessive flows under the spillway could lead to erosion of foundation material and collapse of portions of the spillway.
2. Uncontrolled flows could lead to loss of stored water.

**ACTION REQUIRED****Action:**

1. Immediately measure flow quantity and check flows for transported drain material.
2. If flows are accelerating at a fixed storage level, the reservoir level should be lowered until the flow stabilizes or stops.
3. A qualified engineer should inspect the condition and recommend further actions to be taken.

**ENGINEER REQUIRED**

5.4-11

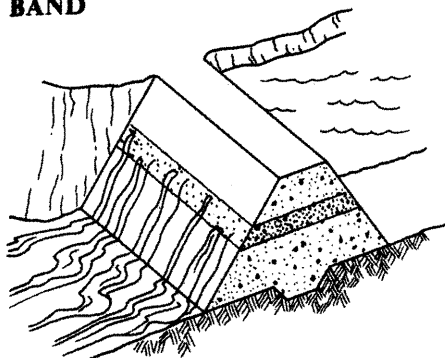
**WET AREA IN HORIZONTAL BAND****Cause:**

Frost layer or layer of sandy material in original construction.

**Harm:**

1. Wetting of areas below the area of excessive seepage can lead to localized instability of the embankment. (SLIDES)
2. Excessive flows can lead to accelerated erosion of embankment materials and failure of the dam.

**Action:**

1. Determine as closely as possible the amount of flow being produced.
2. If flow increases, reservoir level should be reduced until flow stabilizes or stops.
3. Stake out the exact area involved.
4. Using hand tools, try to identify the material allowing the flow.
5. A qualified engineer should inspect the condition and recommend further actions to be taken.

**ENGINEER REQUIRED**

5.4-12

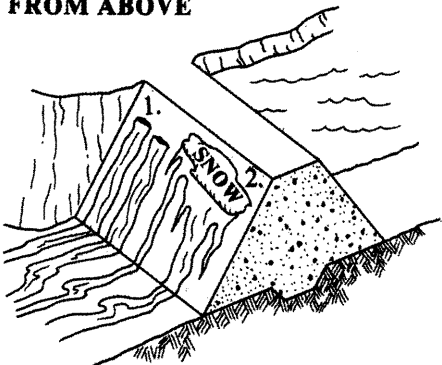
**LARGE AREA SATURATED FROM ABOVE****Cause:**

1. Water flowing through the embankment.
2. Snowdrifts melting slowly during mild spring temperatures.

**Harm:**

Can lead to saturation of embankment materials and local or massive slides which could cause failure of the dam.

**Action:**

1. Investigate saturated area to determine depth and extent of saturation.
2. Inspect daily for developing slides.
3. Water level in reservoir may need to be lowered to assure the safety of the embankment.
4. A qualified engineer should inspect the conditions and recommend further actions to be taken.

**ENGINEER REQUIRED**

## PROBLEM

5.4-13

### SEEPAGE EXITING AT ABUTMENT CONTACT.

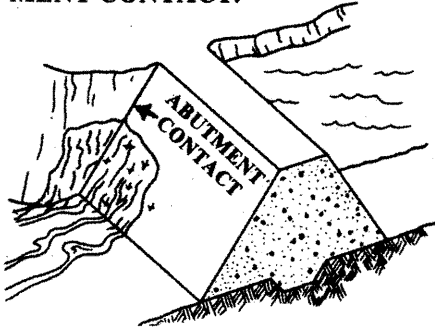

## CAUSES & HARM DONE

### Cause:

1. Water flowing through pathways in the abutment.
2. Water flowing through the embankment.

### Harm:

Can lead to erosion of embankment materials and failure of the dam.

## ACTION REQUIRED

### Action:

1. Investigate leakage area to determine quantity of flow and extent of saturation.
2. Inspect daily for developing slides.
3. Water level in reservoir may need to be lowered to assure the safety of the embankment.
4. A qualified engineer should inspect the conditions and recommend further actions to be taken.

ENGINEER REQUIRED

5.4-14

### LARGE AREA WET OR PRODUCING FLOW

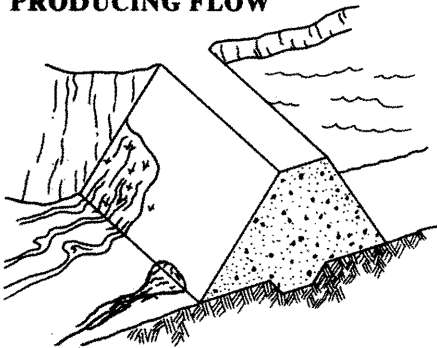

### Cause:

A seepage path has developed through the abutment or embankment.

### Harm:

1. Increased flows could lead to erosion of embankment material and failure of the dam.
2. Saturation of the embankment can lead to local slides which could cause failure of the dam.

### Action:

1. Stake out the saturated area and monitor for growth or shrinking.
2. Measure any outflows as accurately as possible.
3. Reservoir level may need to be lowered if saturated areas increase in size at a fixed storage level or if flow increases.
4. A qualified engineer should inspect the condition and recommend further actions to be taken.

ENGINEER REQUIRED

5.4-15

### MARKED CHANGE IN VEGETATION

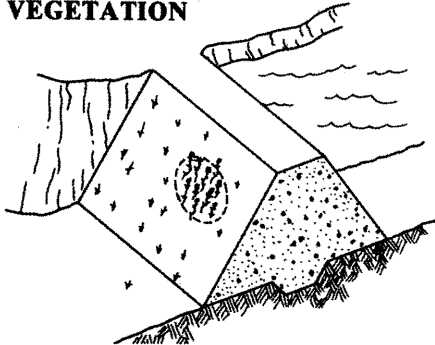

### Cause:

1. Embankment materials are providing flow paths.
2. Natural seeding by wind.
3. Change in seed type during initial post construction seeding.

### Harm:

Can Indicate a saturated area.

### Action:

1. Use probe and shovel to establish if the materials in this area are wetter than in surrounding areas.
2. If area shows wetness when surrounding areas do not, a qualified engineer should inspect the condition and recommend further actions to be taken.

ENGINEER REQUIRED

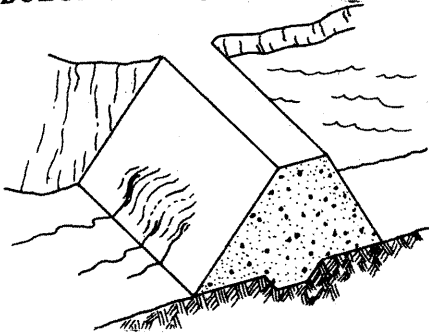
**PROBLEM****5.4-16  
BULGE IN LARGE WET AREA****CAUSES & HARM DONE****Cause:**

Downstream embankment materials have begun to move.

**Harm:**

Failure of the embankment due to massive sliding can follow these initial movements.

**ACTION REQUIRED****Action:**

1. Compare embankment cross-section to the end of construction condition to see if observed condition may reflect end of construction.
2. Stake out affected area and accurately measure outflow.
3. A qualified engineer should inspect the condition and recommend further actions to be taken.

**ENGINEER REQUIRED**

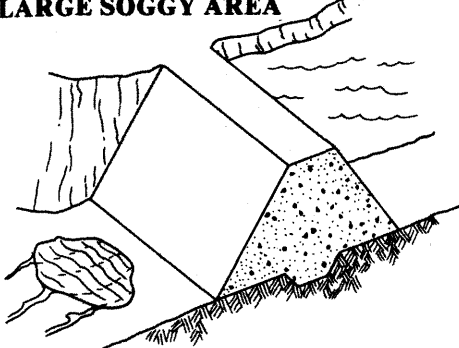
**5.4-17  
TRAMPOLINE EFFECT IN  
LARGE SOGGY AREA****Cause:**

Water moving rapidly through the embankment or foundation is being controlled or contained by a well-established turf root system.

**Harm:**

Condition indicates excessive seepage in the area. If control layer of turf is destroyed, rapid erosion of foundation materials could result in failure of the dam.

**Action:**

1. Carefully inspect the area for outflow quantity and any transported materials.
2. A qualified engineer should inspect the condition and recommend further actions to be taken.

**ENGINEER REQUIRED**

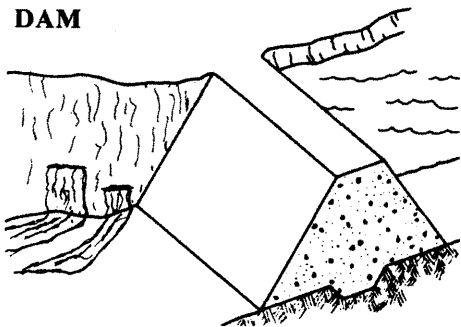
**5.4-18  
LEAKAGE FROM  
ABUTMENTS BEYOND THE  
DAM****Cause:**

Water moving through cracks and fissures in the abutment materials.

**Harm:**

1. Can lead to rapid erosion of abutment and evacuation of the reservoir.
2. Can lead to massive slides near or downstream from the dam.

**Action:**

1. Carefully inspect the area to determine quantity of flow and amount of transported material.
2. A qualified engineer or geologist should inspect the condition and recommend further actions to be taken.

**ENGINEER REQUIRED**

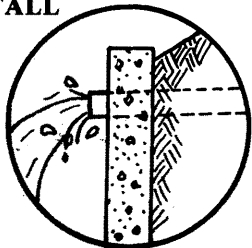
**5.4-19  
LARGE INCREASE IN FLOW  
OR SEDIMENT IN DRAIN  
OUTFALL****Cause:**

A shortened seepage path or increased storage levels.

**Harm:**

1. Higher velocity flows can cause erosion of drain then embankment materials.
2. Can lead to piping failure.

**Action:**

1. Accurately measure outflow quantity and determine amount of increase over previous flow.
2. Collect jar samples to compare turbidity.
3. If either quantity or turbidity has increased by 25% a qualified engineer should evaluate the condition and recommend further actions.

**ENGINEER REQUIRED**



6.1 INTRODUCTION

Now our attention will be concentrated on problems that can be found on the upstream slope, in order to allow the owners to identify conditions that threaten the safety and long life of a dam. Although most of these items can be corrected by normal maintenance, more serious conditions will require inspections by the State Engineer's office and may require further investigation by an experienced consulting engineer. The items requiring the attention of an engineer will be noted as "ENGINEER REQUIRED" on the Field Conditions Chart — Upstream Slope which is provided at the end of this chapter.



PHOTO 6.1 — EXCELLENT UPSTREAM FACE. Note uniform surface of riprap protection.

6.2 ITEMS OF PARTICULAR CONCERN

As the owner criss-crosses the upstream slope during an inspection, he should look carefully for these three items:

- Cracks
- Slides
- Lack of protection of the upstream face

The first two of these conditions may indicate serious problems within the embankment.

Looking for and spotting cracks is difficult. The slope must be transversed in such a manner that the inspector is likely to walk over the cracks. Cracks may be only an inch or two wide but 2 or 3 feet deep. Usually a depth of 3 feet shows that the crack is not a harmless drying type crack. A 20-foot-long line of recently dislodged riprap along the upstream slope could indicate a crack underneath the riprap. Cracks indicate possible foundation movement, embankment failure, or a surface slide.

Slides are almost as difficult to spot as cracks. Their appearance is subtle, since there may be only about 2 feet of settlement or bulging out from the normal slope in a distance of perhaps 100 feet. Also, when the dam was finished, it may not have been uniformly graded by the bulldozer or grader operator. A good familiarity with how the slope looked at the end of construction helps identify any new slides.

The lack of protection against wave action on the upstream slope leads to erosion, and the decrease of the embankment width and/or elevation which could allow water to overflow the crest.

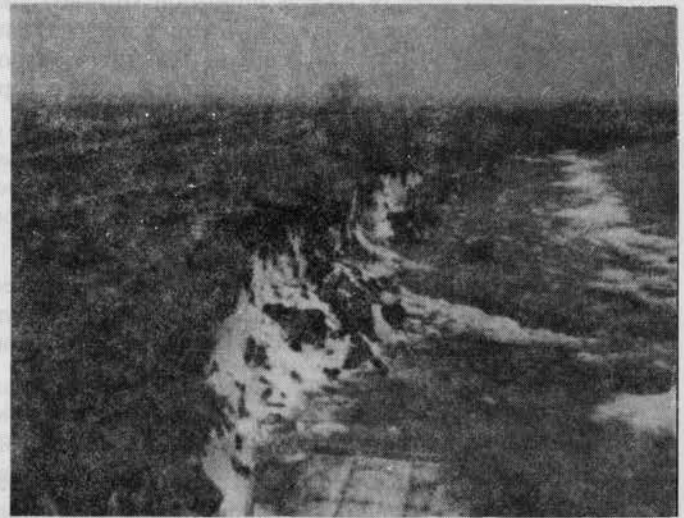

PHOTO 6.2 — EROSION OF UPSTREAM FACE DUE TO LACK OF PROTECTION AGAINST WAVE ACTION.

6.3 SPECIAL INSPECTION TECHNIQUES

When walking on riprap, caution should be used to avoid losing one's footing. Most important, a criss-cross path should be used for inspecting the slope so that cracks and slides can be more easily seen. Many times the water-line alignment will indicate a change in the uniformity of the slope. The inspector should stand at one end of the dam and sight along the water line. Also, if a crack is seen, the crest and downstream slope in that area should be carefully inspected to note any other changes in that area of the embankment that could be associated with the upstream crack.

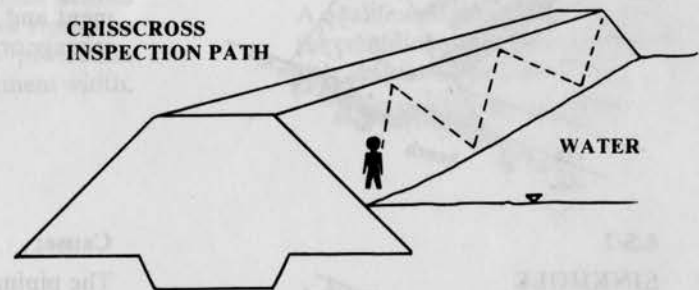

FIGURE 6.3-1 — USING CRISSCROSS INSPECTION PATH

6.4 TYPICAL MATERIALS

This information is presented to describe the array of materials that can be used on the upstream slope.

- a. **UNPROTECTED EMBANKMENT** is composed of soils only and is exposed to wave action and susceptible to erosion. Soil alone is adequate for only small, gently sloped embankments where no scarping is occurring. When scarping does occur, protection must be improved to protect the dam.

- b. **ROCK RIPRAP WITH BEDDING** is composed of rock graded from 3/16 inch to 3½ inches, which prevents soil from being washed out through the voids in the larger rock riprap. Riprap is larger rock that is designed for thicknesses that prevent wave action from eroding the embankment. Using various sizes of rock is important so that rocks lodge between other rocks forming a dense mat. The slope should be gentle so that rocks do not tumble to the bottom of the slope due to oversteepness.
- c. **CONCRETE** is comprised of concrete slabs that provide a facing covering the upstream slope. Joints must be watertight to prevent erosion of soil that is behind the concrete.
- d. **SOIL CEMENT** is a mixture of water, pulverized soil, and portland cement. When properly constructed, it provides low cost, durable protection against wave action.
- e. **ASPHALT PAVING** is asphaltic concrete laid against a designed gravel bedding.
- f. **STEEL** is composed of steel plate welded together with a good design that includes expansion-contraction joints.

## 6.5 FIELD CONDITIONS ENCOUNTERED

### 6.6 SUMMARY

The three major problems encountered for an upstream slope are:

Cracks

Slides

Lack of protection from wave action

The upstream slope needs a thorough inspection, since the slope protection and water stored can hide problems. When the reservoir is emptied, the slope should be thoroughly inspected for settlement areas, rodent activity, sinkholes, or slides. Also, the reservoir basin (bottom of the reservoir) should be inspected for sink holes or settlement.

The dam's owner, by applying the maximum prudent effort, can identify any changes in previously noted conditions that indicate a safety problem. A conscientious annual maintenance program will address and control most of the conditions identified above. When a questionable condition is found, the state's dam safety engineers should be notified immediately.

Quick corrective action to conditions requiring attention will promote the safety and extend the useful life of the dam while possibly preventing costly future repairs.

## PROBLEM

### 6.5-1

#### SCARPS, BENCHES, OVERSTEEP AREAS

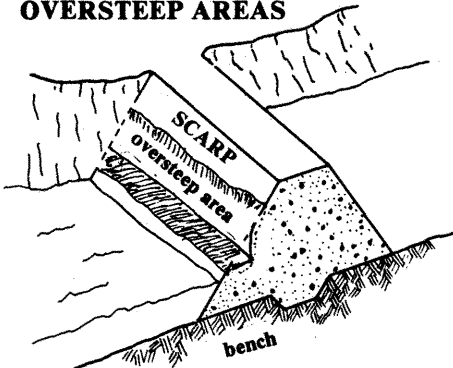

## CAUSES & HARM DONE

### Cause:

Wave action, local settlement, or ice action cause soil and rock to erode and slide to the lower part of the slope forming a bench.

### Harm:

This eroded area lessens the width and possible height of the embankment and could lead to increased seepage or overtopping of the dam.

## ACTION REQUIRED

### Action:

Determine exact cause of scarps. Do necessary earthwork, restore embankment to original slope, provide adequate protection (bedding and riprap). See Chapter 13.

### 6.5-2

#### SINKHOLE

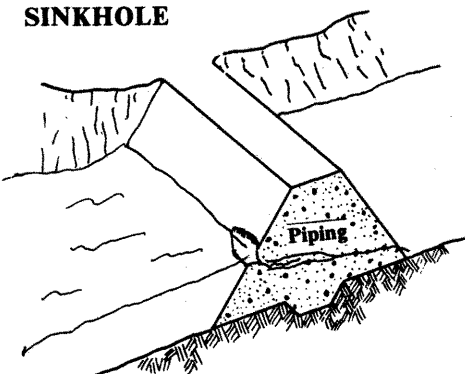

### Cause:

The piping of embankment material or foundation material causes a sink hole. The cave-in of an eroded cavern can result in a sink hole. A small hole in the wall of an outlet pipe can develop a sink hole.

### Harm:

This condition can empty a reservoir through a small hole in the wall of an outlet pipe or can lead to failure of a dam as soil pipes through the foundation or a pervious portion of the dam.

### Action:

Inspect other portions of the dam for seepage or additional sink holes. Identify exact cause of sink holes. Check seepage and leakage outflows for dirty water.

A qualified engineer should inspect the conditions and recommend further actions to be taken.

**ENGINEER REQUIRED**

## PROBLEM

6.5-3

### SLIDE, SLUMP OR SLIP

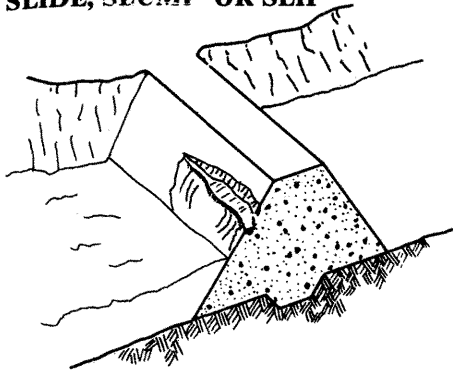

6.5-4

### BROKEN DOWN, MISSING RIPRAP

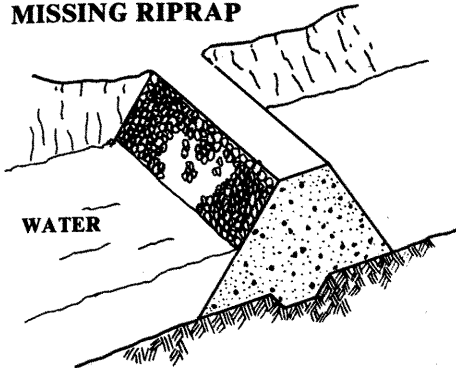

6.5-5

### EROSION BEHIND POORLY GRADED RIPRAP

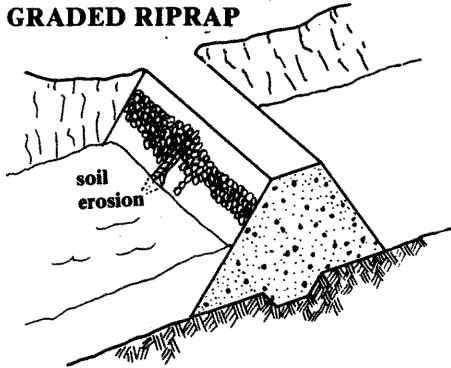

6.5-6

### LARGE CRACKS

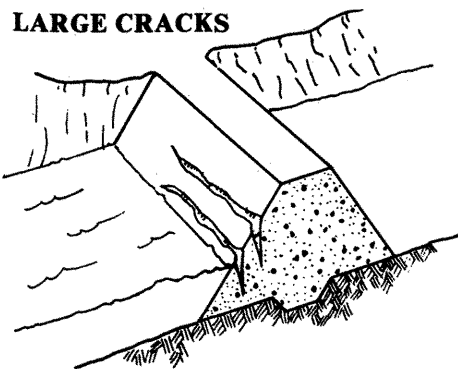

## CAUSES & HARM DONE

### Cause:

Earth or rocks move down the slope along a slippage surface because they were on too steep a slope, or the foundation moves. Also, look for slides in reservoir basin.

### Harm:

A series of slides can lead to obstruction of the outlet or failure of the dam.

### Cause:

Poor quality riprap has deteriorated. Wave action or ice action has displaced riprap. Round and similar-sized rocks have rolled downhill.

### Harm:

Wave action against these unprotected areas decreases embankment width.

### Cause:

Similar-sized rocks allow waves to pass between them and erode small gravel particles and soil.

### Harm:

Soil is eroded away from behind the riprap. This allows riprap to settle, providing less protection and decreased embankment width.

### Cause:

A portion of the embankment has moved due to loss of strength, or the foundation may have moved, causing embankment movement.

### Harm:

Can lead to failure of the dam.

## ACTION REQUIRED

### Action:

Evaluate extent of the slide. Monitor slide. (See Chapter 12.)

Draw the reservoir level down if safety of dam is threatened.

A qualified engineer should inspect the conditions and recommend further actions to be taken.

**ENGINEER REQUIRED**

### Action:

Re-establish normal slope. Place bedding and competent riprap. (See Chapter 13.)

### Action:

Re-establish effective slope protection. Place bedding material. **ENGINEER REQUIRED** for design of gradation and size of rock for bedding and riprap.

A qualified engineer should inspect the conditions and recommend further actions to be taken.

**ENGINEER REQUIRED**

### Action:

Depending on the amount of embankment involved, draw reservoir level down.

A qualified engineer should inspect the conditions and recommend further actions to be taken.

**ENGINEER REQUIRED**

**PROBLEM**

6.5-7

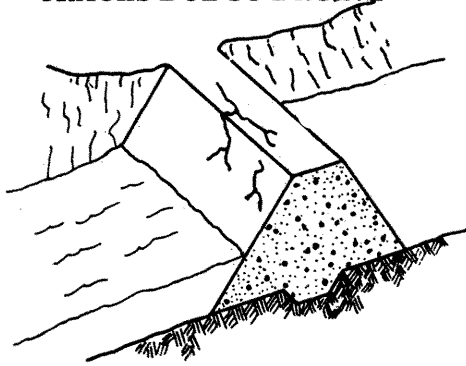
**CRACKS DUE TO DRYING****CAUSES & HARM DONE****Cause:**

The soil loses its moisture and shrinks, causing cracks.

**Note:**

Usually seen on crest and downstream slope mostly.

**Harm:**

Heavy rains can fill up cracks and cause small portions of embankment to move along internal slip surface.

**ACTION REQUIRED****Action:**

1. Monitor cracks for increases in width, depth, or length.
2. A qualified engineer should inspect the condition and recommend further actions to be taken.

**ENGINEER REQUIRED**

6.5-8

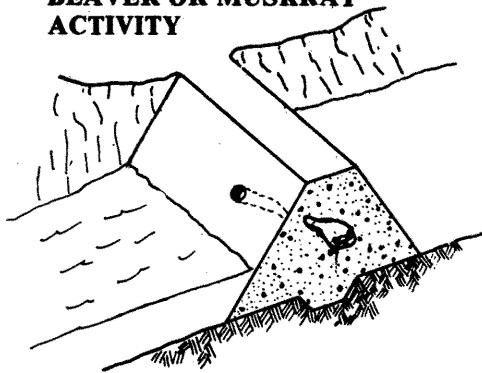
**BEAVER OR MUSKRAT ACTIVITY****Cause:**

Holes, tunnels, and caverns are caused by animal burrowings. Certain habitats like cattail type plants and trees close to the reservoir encourage these animals.

**Harm:**

If a tunnel exists through most of the dam, it can lead to failure of the dam.

**Action:**

Remove rodents. Determine exact location of digging and extent of tunneling. Remove habitat. Repair damages. (See Earthwork, Chapter 13.2.)

6.5-9

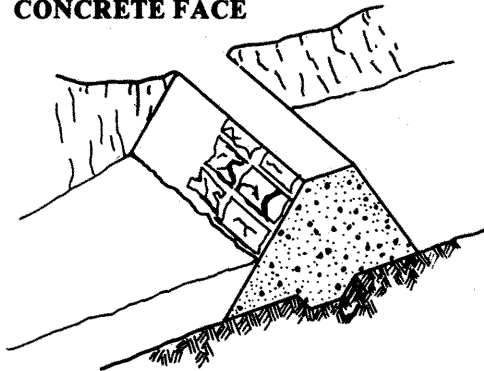
**CRACKED DETERIORATED CONCRETE FACE****Cause:**

Concrete deteriorated due to weathering. Joint filler deteriorated or displaced.

**Harm:**

Soil is eroded behind the face and caverns can be formed. Unsupported sections of concrete crack. Ice action may displace concrete.

**Action:**

1. Determine cause. Either patch with grout or contact engineer for permanent repair method.
2. If damage is extensive a qualified engineer should inspect the conditions and recommend further actions to be taken.

**ENGINEER REQUIRED**



PHOTO 6.5-1 — UNIFORM POORLY SIZED RIPRAP LEADS TO EROSION OF SOIL BEHIND RIPRAP.



PHOTO 6.5-4 — MUSKRAT DAMAGE



PHOTO 6.5-2 — CRACK IN UPSTREAM SLOPE



PHOTO 6.5-5 — BADLY DETERIORATED CONCRETE FACE



PHOTO 6.5-3 — CRACK IN UPSTREAM SLOPE



PHOTO 6.5-6 — SLIDE AT UPSTREAM SLOPE. Note water line alignment.

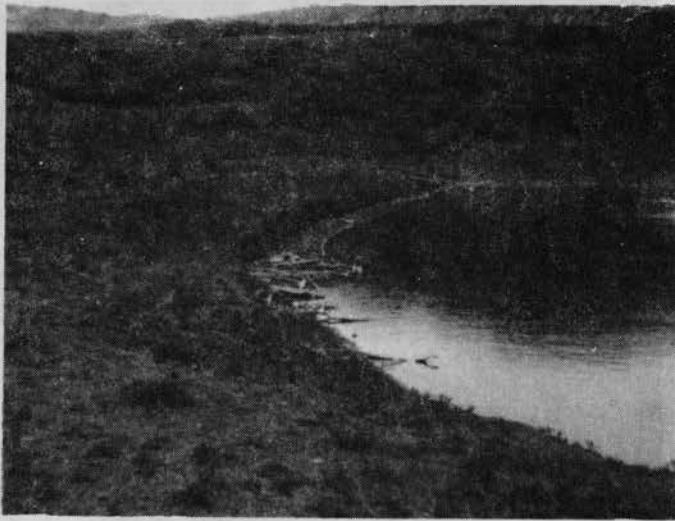

**PHOTO 6.5-7 — EROSION AT UPSTREAM FACE**



**PHOTO 6.5-8 — 21' x 21' SINK HOLE IN RESERVOIR BASIN**

7.1 INTRODUCTION

Now our attention will be concentrated on the crest of the dam in order to allow owners to identify conditions that threaten the safety and long life of their dam. Although some of these conditions can be corrected by normal maintenance, more serious deficiencies will require inspection by the State Engineer's Office and may require further investigation by an experienced consulting engineer. The conditions requiring the attention of an engineer will be designated by the notation "ENGINEER REQUIRED" on the table presented in section 7.5 of this chapter.

7.2 TYPICAL MATERIALS

This information is presented to describe to the reader the array of materials that can be found on the crest of dams. The type of materials that are used or found on the crest are often dictated by dam design or anticipated usage of the crest, including access and roadway requirements. Common materials encountered include native earth, gravel, rock, concrete, or asphalt.

When access across the dam is needed only for maintenance operations that can be scheduled during favorable weather conditions, no special crest surfacing is required. In these cases, the crest surfacing is usually composed of native earthen materials placed during original embankment construction. If access across the dam is imperative under all weather conditions for the safe and routine operation of the dam, the crest should be surfaced with a minimum of 4 inches of gravel or roadbase material.

If the dam is a rockfilled structure, the crest will also be rock. Again, if access is required, the top of the rockfill is often smoothly finished or gravel is placed on the crest to provide a smooth roadway.

If the crest conveys a road or highway, it should be surfaced with a properly engineered roadway of roadbase material, asphalt, or reinforced concrete. The crest surfacing must be capable of withstanding the expected traffic loading and preventing damage to the underlying dam structure.

If the dam contains an impervious core, adequate protective material should be provided on the crest to protect the core from damage by frost heave and from the formation of drying cracks at the top of the impervious core. In all cases, it is preferable that the material used to cover the crest be a material that will not shrink or crack when dried out. This will prevent the formation of drying cracks in the embankment and the possible infiltration of surface runoff into the dam's cross-section through the surface cracking.

7.3 ITEMS OF PARTICULAR CONCERN

On the crest, some of the more threatening conditions that may be identified during inspection are:

7.3-1 **LONGITUDINAL CRACKING** can indicate localized instability, differential settlement, and/or movement between adjacent sections of the embankment. Longitudinal cracking is characterized by a single crack or a close, parallel system of cracks along the crest in a direction more or less parallel to the length of the dam.

(See Photo 7.3-1.) These cracks, which are continuous over their length and are usually greater than 1 foot deep, can be differentiated from drying cracks which are usually intermittent, erratic in pattern, shallow, very narrow, and numerous.

Longitudinal cracking may precede vertical displacement as the dam attempts to move to a position of greater stability. (See Photo 7.3-2.) Vertical displacements on the crest are usually accompanied by displacements on the upstream or downstream face of the dam. An example of the development of a longitudinal crack into vertical displacement can be seen in Figure 7.3-1.



PHOTO 7.3-1 — SEVERE LONGITUDINAL CRACKING. Cracking pattern indicates horizontal movement between adjacent sections of the dam. Note the close parallel cracks.

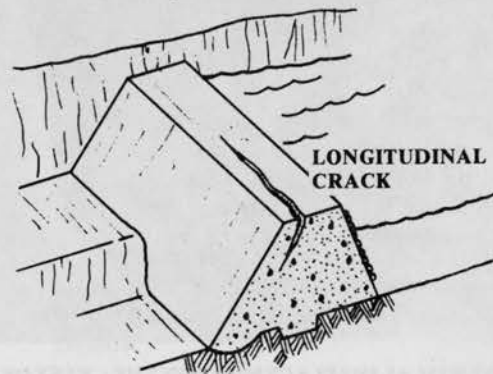

A) Initial Longitudinal Cracking

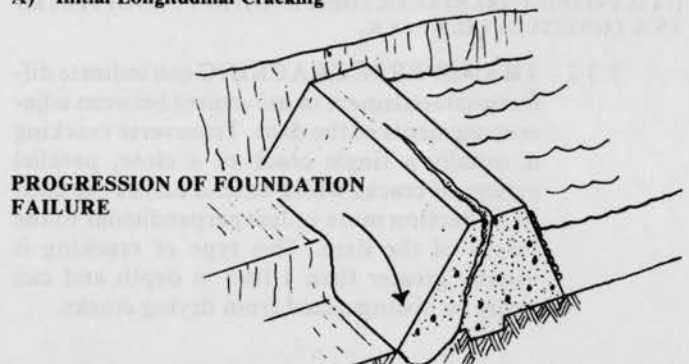

B) Progression of Longitudinal Cracking

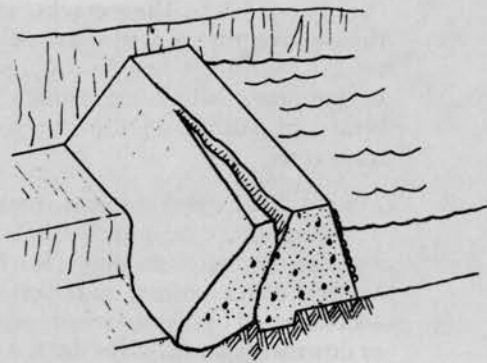

DISPLACEMENT OR MOVEMENT ON DOWNSTREAM FACE

C) Initial Displacement

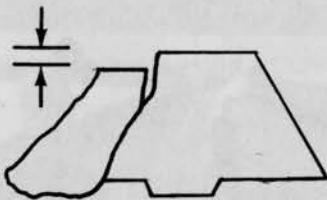

VERTICAL DISPLACEMENT

D) Longitudinal Crack Progressing Into Vertical Displacement

FIGURE 7.3-1

LONGITUDINAL CRACK PRECEDES EMBANKMENT FAILURE



PHOTO 7.3-2 — VERTICAL DISPLACEMENT ON THE CREST OF A DAM. IN ITS INITIAL STAGES, THIS CONDITION WAS DETECTED AS A LONGITUDINAL CRACK.

7.3-2 **TRANSVERSE CRACKING** can indicate differential settlement or movement between adjacent segments of the dam. Transverse cracking is usually a single crack or a close, parallel system of cracks which extend across the crest in a direction more or less perpendicular to the length of the dam. This type of cracking is usually greater than 1 foot in depth and can easily be distinguished from drying cracks.

Transverse cracking poses a definite threat to the safety and integrity of the dam. If the crack should progress to a point below the reservoir water surface elevation, seepage could progress along the crack and through the embankment cross-section. This could evolve into a piping situation, and if not corrected, lead to the failure of the dam. An example of the progression of the transverse crack can be seen in Figure 7.3-2.

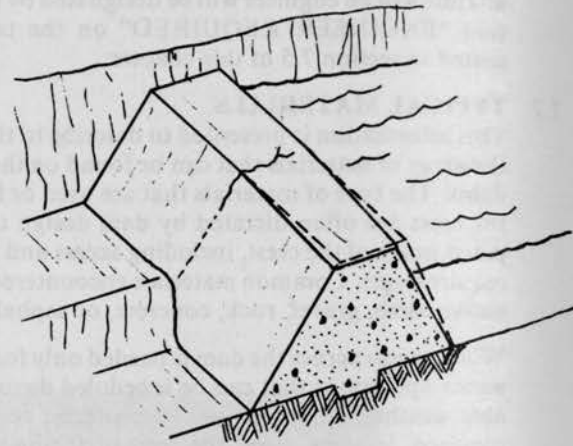
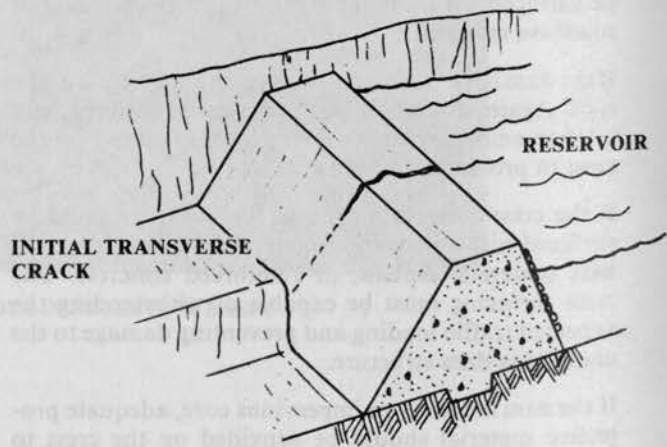

FIGURE 7.3-2

TRANSVERSE CRACKING

Because of difference in settlement between high and low sections of the embankment, a transverse crack can form through embankment section.



A) Initial Transverse Cracking

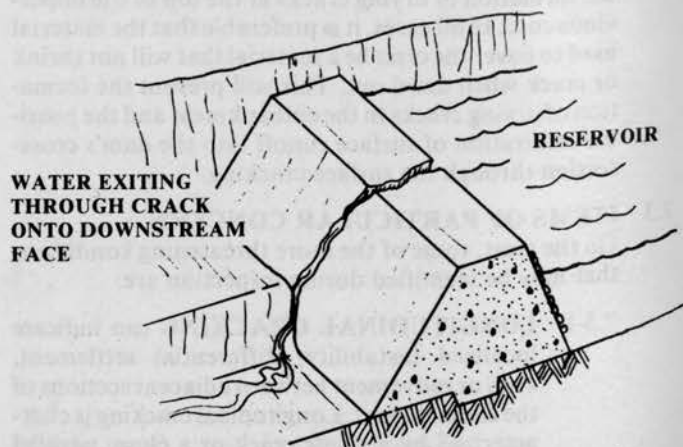

B) Progression of Transverse Crack to a Point Below the Waterline.



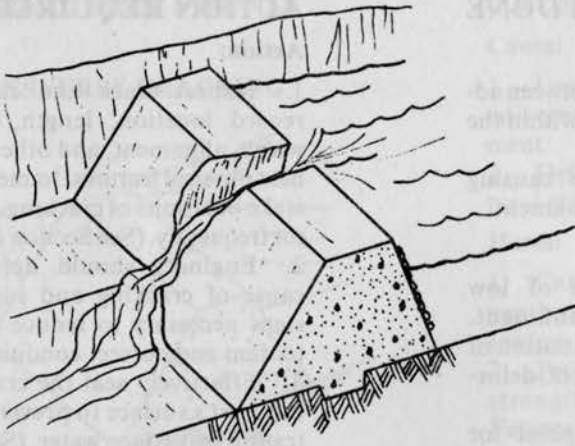

C) Transverse Cracking Progressed to an Overtopping Situation — Condition Has Progressed to a Point of Imminent Failure.

FIGURE 7.3-3  
TRANSVERSE CRACKING LEADS TO FAILURE

- 7.3-3 **MISALIGNMENT** can indicate relative movement between adjacent portions of the dam in directions perpendicular to the axis of the dam (See Photo 7.3-4).

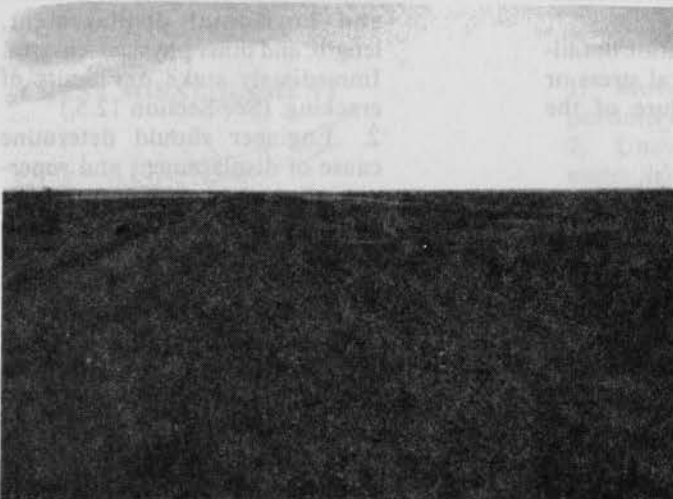

PHOTO 7.3-3 — WELL-GRADED STRAIGHT CREST OF A NEWLY COMPLETED DAM.



PHOTO 7.3-4 — CREST IN POOR CONDITION SHOWING EVIDENCE OF MISALIGNMENT.

If these conditions are identified or suspected, the State Engineer's Office should be notified immediately.

#### 7.4 SPECIAL INSPECTION TECHNIQUES

The items of particular concern noted above are usually visibly detectable during a thorough and complete inspection of the dam, as described in Chapter 4. While detection of longitudinal cracking, vertical displacement, or transverse cracking depends on a careful, thorough, and methodical visual inspection of the crest surface, misalignment may only be detectable by a general overview of the dam from either abutment. (See Figure 4.4-2.)

If the crest is straight for the length of the structure, alignment is best checked by standing away from the dam on either abutment and sighting along the upstream and downstream edges of the crest. On curved dams, alignment may best be checked by standing at either end of a straight segment of the dam and sighting along the crest's upstream and downstream edges, noting any curvature or misalignment in that section.

#### 7.5 PROBLEM CONDITIONS FOUND ON THE CREST

Following are sketches of conditions that may be found on the crest of the dam during an inspection. While most of the conditions on the following tables can be corrected by routine and periodic maintenance conducted by the owner, some of the conditions noted are of a nature that threaten the safety and integrity of the dam and require the attention of an experienced professional engineer. Conditions requiring the attention of an engineer are identified by the notation "ENGINEER REQUIRED" under the "ACTION REQUIRED" column of the tables.

#### 7.6 SUMMARY

The dam's crest usually provides the primary access for inspection and maintenance. Since surface water will pond on the crest unless that surface is well maintained, this part of the dam usually requires periodic regrading. Problems found on the crest should not be graded over. When a questionable condition is found, the state's dam safety engineers should be notified immediately.

Quick corrective action applied to conditions requiring attention will promote the safety and extend the useful life of the dam while possibly preventing costly future repairs.

## CONDITION FOUND

7.5-1

### LONGITUDINAL CRACK

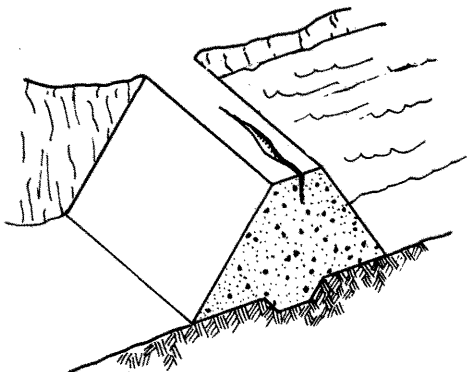

Also see Photo 7.3-1.

7.5-2

### VERTICAL DISPLACEMENT

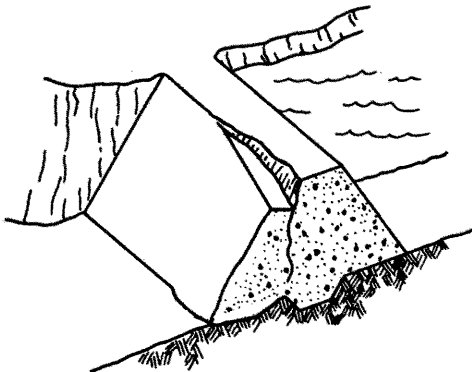

Also see Photo 7.5-1 and Photo 7.3-2.

## CAUSES & HARM DONE

### Cause:

1. Uneven settlement between adjacent sections or zones within the embankment.
2. Foundation failure causing loss of support to embankment.

### Harm:

1. Creates local area of low strength within embankment. Could be the point of initiation of future structural movement, deformation, or failure.
2. Provides entrance point for surface run-off into embankment, allowing saturation of adjacent embankment area, and possible lubrication which could lead to localized failure.

### Cause:

1. Vertical movement between adjacent sections of the embankment.
2. Structural deformation or failure caused by structural stress or instability, or by failure of the foundation.

### Harm:

1. Provides local area of low strength within embankment which could cause future movement.
2. Leads to structural instability or failure.
3. Provides entrance point for surface water that could further lubricate failure plane.
4. Reduces available embankment cross section.

## ACTION REQUIRED

### Action:

1. Inspect crack and carefully record location, length, depth, width, alignment, and other pertinent physical features. Immediately stake out limits of cracking. Monitor frequently. (See Section 12.5-2.)
2. Engineer should determine cause of cracking and supervise steps necessary to reduce danger to dam and correct condition.
3. Effectively seal the cracks at the crest's surface to prevent infiltration by surface water. (See Section 13.2.)
4. Continue to routinely monitor crest for evidence of further cracking.

ENGINEER REQUIRED

### Action:

1. Carefully inspect displacement and record its location, vertical and horizontal displacement, length, and other physical features. Immediately stake out limits of cracking. (See Section 12.5.)
2. Engineer should determine cause of displacement and supervise all steps necessary to reduce danger to dam and correct condition.
3. Excavate area to the bottom of the displacement. Backfill excavation, using competent material and correct construction techniques, under supervision of engineer.
4. Continue to monitor areas routinely for evidence of future cracking or movement. (See Section 12.5.)

ENGINEER REQUIRED

## CONDITION FOUND

7.5-3

### TRANSVERSE CRACKING

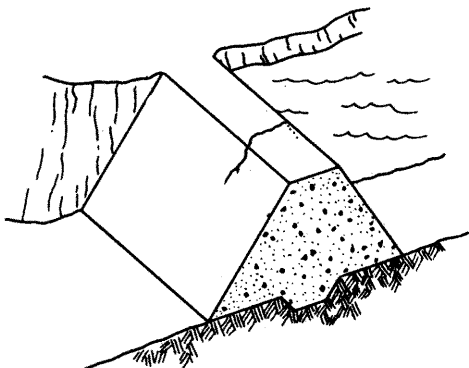

## CAUSES & HARM DONE

### Cause:

1. Uneven movement between adjacent segments of the embankment.
2. Deformation caused by structural stress or instability.

### Harm:

1. Can provide a path for seepage through the embankment cross section.
2. Provides local area of low strength within embankment. Future structural movement, deformation, or failure could begin at this point.
3. Provides entrance point for surface run-off to enter embankment.

## ACTION REQUIRED

### Action:

1. Inspect crack and carefully record crack location, length, depth, width, and other pertinent physical features. Stake out limits of cracking. (See Section 12.5-2.)
2. Engineer should determine cause of cracking and supervise all steps necessary to reduce danger to dam and correct condition.
3. Excavate crest along crack to a point below the bottom of the crack. Then backfill excavation using competent material and correct construction techniques. This will seal the crack against seepage and surface run-off. (See Section 13.2.) This should be supervised by engineer.
4. Continue to monitor crest routinely for evidence of future cracking. (See Section 12.5.)

ENGINEER REQUIRED

7.5-4

### CREST MISALIGNMENT

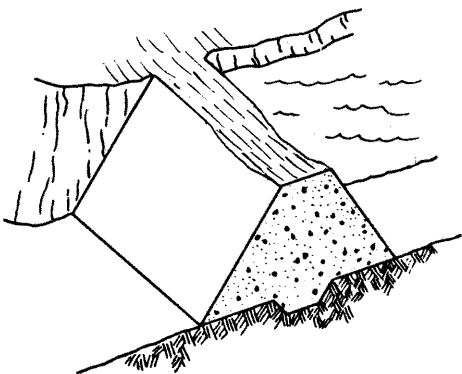

### Cause:

1. Movement between adjacent portions of the structure.
2. Uneven deflection of dam under loading by reservoir.
3. Structural deformation or failure near area of misalignment.

### Harm:

1. Area of misalignment is usually accompanied by low area in crest which reduces free board.
2. Can produce local areas of low embankment strength which may lead to failure.

### Action:

1. Establish monuments across crest to determine exact amount, location, and extent of misalignment. (See Section 12.5-1.)
2. Engineer should determine cause of misalignment and supervise all steps necessary to reduce threat to dam and correct condition.
3. Monitor crest monuments on a scheduled basis following remedial action to detect possible future movement. (See Section 12.5-1.)

ENGINEER REQUIRED

Also see Photo 7.3-4

## CONDITION FOUND

7.5-5

### LOW AREA IN CREST OF DAM

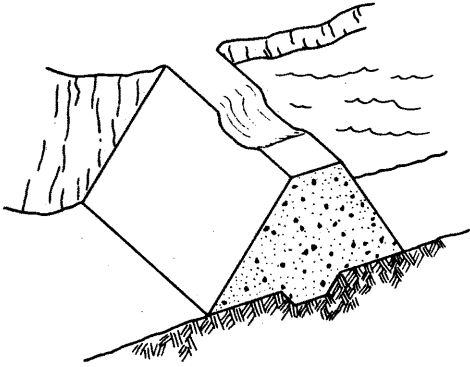

Also see Photo 7.5-2.

## CAUSES & HARM DONE

### Cause:

1. Excessive settlement in the embankment or foundation directly beneath the low area in the crest.
2. Internal erosion of embankment material.
3. Foundation spreading toward upstream and/or downstream direction.
4. Prolonged wind erosion of crest area.
5. Improper final grading following construction.

### Harm:

Reduces freeboard available to pass flood flows safely through spillway.

## ACTION REQUIRED

### Action:

1. Establish monuments along length of crest to determine exact amount, location, and extent of settlement in crest. (See Section 12.5-1.)
2. Engineer should determine cause of low area and supervise all steps necessary to reduce possible threat to the dam and correct condition.
3. Re-establish uniform crest elevation over crest length by placing fill in low area using proper construction techniques. (See Section 13.2.) This should be supervised by engineer.
4. Re-establish monuments across crest of dam and monitor monuments on a routine basis to detect possible future settlement. (See Section 12.5-1.)

ENGINEER REQUIRED

7.5-6

### SINKHOLE IN CREST

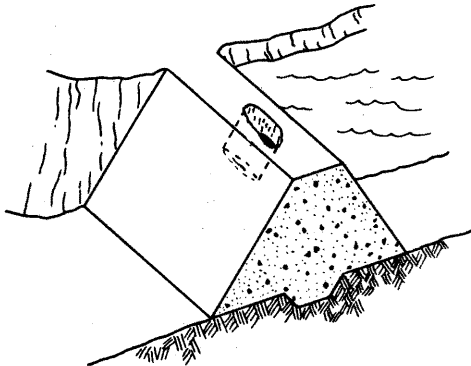

Also see Photo 7.5-3.

### Cause:

1. Rodent activity.
2. Hole in outlet conduit is causing erosion of embankment material.
3. Internal erosion or piping of embankment material by seepage.
4. Breakdown of dispersive clays within embankment by seepage waters.

### Harm:

1. Void within dam could cause localized caving, sloughing, instability, or reduced embankment cross section.
2. Entrance point for surface water.

### Action:

1. Carefully inspect and record location and physical characteristics (depth, width, length) of sinkhole.
2. Engineer should determine cause of sinkhole and supervise all steps necessary to reduce threat to dam and correct condition.
3. Excavate sinkhole, slope sides of excavation, and backfill hole with competent material using proper construction techniques. (See Section 13.2.) This should be supervised by engineer.

ENGINEER REQUIRED

## CONDITION FOUND

7.5-7

### OBSCURING VEGETATION

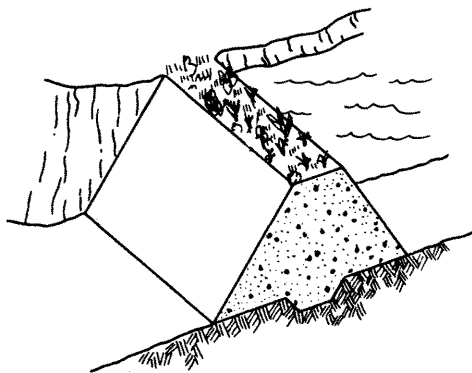

Also see Photo 7.5-4.

## CAUSES & HARM DONE

### Cause:

Neglect of dam and lack of proper maintenance procedures.

### Harm:

1. Obscures large portions of the dam, preventing adequate, accurate visual inspection of all portions of the dam. Problems which threaten the integrity of the dam can develop and remain undetected until they progress to a point that threatens the dam's safety.
2. Associated root systems develop and penetrate into the dam's cross section. When the vegetation dies, the decaying root systems can provide paths for seepage. This reduces the effective seepage path through the embankment and could lead to possible piping situations.
3. Prevents easy access to all portions of the dam for operation, maintenance, and inspection.
4. Provides habitat for rodents.

## ACTION REQUIRED

### Action:

1. Remove all detrimental growth from the dam. This would include removal of trees, bushes, brush, conifers, and growth other than grass. Grass should be encouraged on all segments of the dam to prevent erosion by surface run-off. Root systems should also be removed to the maximum practical extent. The void which results from removing the root system should be backfilled with competent, well-compacted material. (See Section 13.1.)
2. Future undesirable growth should be removed by cutting or spraying, as part of an annual maintenance program. (See Section 13.1.)
3. All cuttings or debris resulting from the vegetative removal should be immediately taken from the dam and properly disposed of outside the reservoir basin.

7.5-8

### RODENT ACTIVITY

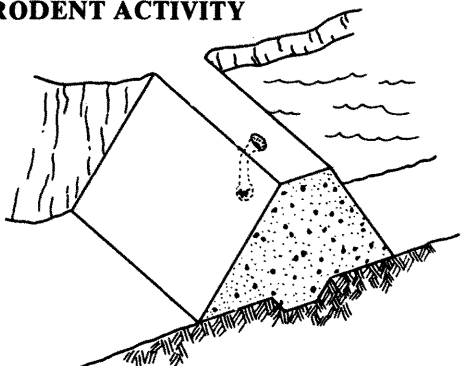

Also see Photo 7.5-5.

### Cause:

Burrowing animals.

### Harm:

1. Entrance point for surface run-off to enter dam. Could saturate adjacent portions of the dam.
2. Especially dangerous if hole penetrates dam below phreaticline. During periods of high storage, seepage path through the dam would be greatly reduced and a piping situation could develop.

### Action:

1. Completely backfill the hole with competent, well compacted material. (See Section 13.2.)
2. Initiate a rodent control program to prevent the propagation of the burrowing animal population and to prevent future damage to the dam. (See Section 13.3.)

7.5-9

### GULLY ON CREST

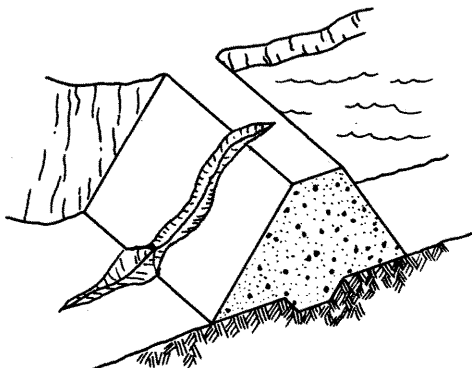

Also see Photo 7.5-6.

### Cause:

1. Poor grading and improper drainage of crest. Improper drainage causes surface run-off to collect and drain off crest at low point in upstream or downstream shoulder.
2. Inadequate spillway capacity which has caused dam to overtop.

### Harm:

1. Can reduce available freeboard.
2. Reduces cross-sectional area of dam.
3. Inhibits access to all parts of the crest and dam.

### Action:

1. Restore freeboard to dam by adding fill material in low area, using proper construction techniques. (See Section 13.2.)
2. Regrade crest to provide proper drainage of surface run-off.
3. If gully was caused by overtopping, provide adequate spillway which meets current design standards. This should be done by engineer.
4. Re-establish protective cover.

## CONDITION FOUND

7.5-10

### RUTS ALONG CREST

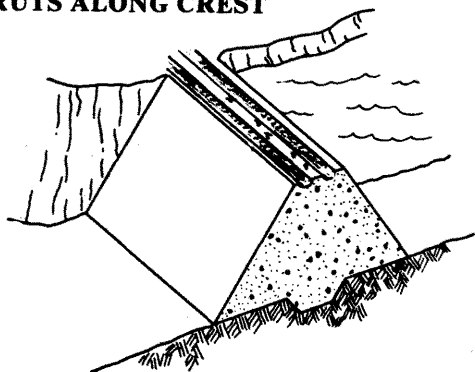

Also see Photo 7.5-7.

7.5-11

### PUDDLING ON CREST — POOR DRAINAGE

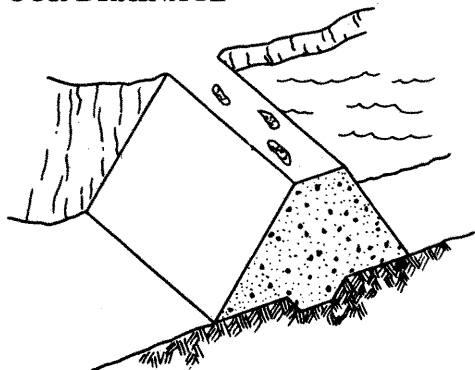

Also see Photo 7.3-4.

7.5-12

### DRYING CRACKS

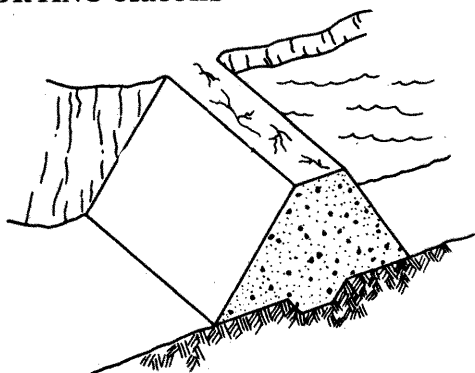

Also see Photo 7.5-8.

## CAUSES & HARM DONE

### Cause:

Heavy vehicle traffic without adequate or proper maintenance or proper crest surfacing.

### Harm:

1. Inhibits easy access to all parts of crest.
2. Allows continued development of rutting.
3. Allows standing water to collect and saturate crest of dam.
4. Operating and maintenance vehicles can get stuck.

### Cause:

1. Poor grading and improper drainage of crest.
2. Localized consolidation or settlement on crest allows puddles to develop.

### Harm:

1. Causes localized saturation of the crest.
2. Inhibits access to all portions of the dam and crest.
3. Becomes progressively worse if not corrected.

### Cause:

Material on the crest of dam expands and contracts with alternate wetting and drying of weather cycles. Drying cracks are usually short, shallow, narrow, and numerous.

### Harm:

Provides point of entrance for surface run-off and surface moisture, causing saturation of adjacent embankment areas. This saturation and subsequent drying of the dam could cause further cracking.

## ACTION REQUIRED

### Action:

1. Drain standing water from ruts.
2. Regrade and recompact crest to restore integrity and provide proper drainage toward upstream slope. (See Section 13.2.)
3. Provide gravel or roadbase material to accommodate traffic.
4. Perform periodic maintenance and regrading to prevent reformation of ruts.

### Action:

1. Drain standing water from puddles.
2. Regrade and recompact crest to restore integrity and provide proper drainage toward upstream slope. (See Section 13.2.)
3. Provide gravel or roadbase material to accommodate traffic.
4. Perform periodic maintenance and regrading to prevent reformation of low areas.

### Action:

1. Seal surface of cracks with a tight, impervious material. (See Section 13.2.)

### OR

2. Routinely grade crest to provide proper drainage and fill cracks.

### OR

3. Cover crest with non-plastic (not clay) material to prevent large moisture content variations with respect to time.

**CONDITION FOUND**

7.5-13

**CREST CAMBER**

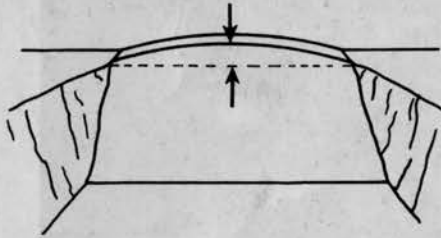

Also see Photo 7.5-9.

**CAUSES & HARM DONE**

**Cause:**

Results from construction. Proportionally more fill is placed on crest in higher segments of the embankment during construction to compensate for anticipated settlement within the dam and foundation.

**Harm:**

None.

**ACTION REQUIRED**

**Action:**

None.



PHOTO 7.5-1.a — VERTICAL DISPLACEMENT ON CREST.



PHOTO 7.5-2 — LOW AREA IN THE CREST OF A DAM, CAUSED BY A FOUNDATION FAILURE.



PHOTO 7.5-1.b — VERTICAL DISPLACEMENT ON THE CREST OF A DAM. This vertical movement was associated with a slip on the downstream face.

SMALL SINKHOLE

LARGE SINKHOLE



PHOTO 7.5-3 — SINKHOLES IN THE CREST OF A DAM, CAUSED BY CONSOLIDATION OF LOW DENSITY EMBANKMENT MATERIAL.



**PHOTO 7.5-4 — THE CREST OF A DAM PARTIALLY OVERGROWN AND OBSCURED DUE TO EXCESSIVE BRUSH GROWTH**



**PHOTO 7.5-5 — RODENT HOLE FOUND ON THE CREST OF A DAM**

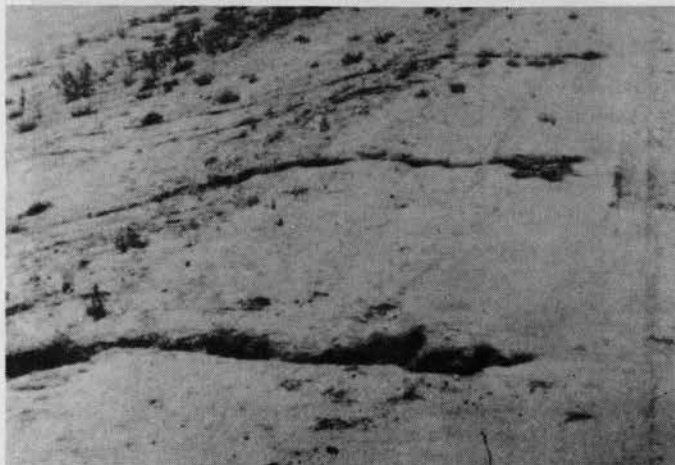

**PHOTO 7.5-6 — RUNOFF GULLIES FORMING ON THE DOWNSTREAM SHOULDER OF THE CREST**



**PHOTO 7.5-7 — RUTS IN THE CREST OF A DAM**



**PHOTO 7.5-8 — LONGITUDINAL DRYING CRACKS ON THE CREST OF A DAM. These cracks are caused by drying of the crest surface and are only 6-8 inches deep.**



**PHOTO 7.5-9 — CAMBER INCORPORATED INTO CREST DURING CONSTRUCTION. Camber is greatest over highest section of the dam.**



8.1 INTRODUCTION

Now our attention will be concentrated on the downstream slope in order to allow the owners to identify conditions that threaten the safety and long life of the dam. Although most of these items can be corrected by normal maintenance, more serious conditions will require inspection by the State Engineer's Office and may require further investigation by an experienced consulting engineer. The items requiring the attention of an engineer will be noted "ENGINEER REQUIRED."

8.2 ITEMS OF PARTICULAR CONCERN

On the downstream slope some of the more threatening conditions that may be identified during inspections are:

- CRACKS
- SLIDES
- SEEPAGE

**Cracks** can indicate settlement, drying and shrinkage, or a slide developing in the embankment. Whatever the cause, cracks should be monitored and changes in length and width noted. A suggested method for monitoring cracks is presented in Section 12.5-2.

Drying cracks may appear and disappear seasonally and normally will not show vertical displacement like that associated with settlement cracks or slide cracks. (See Figure 8.2-1.)

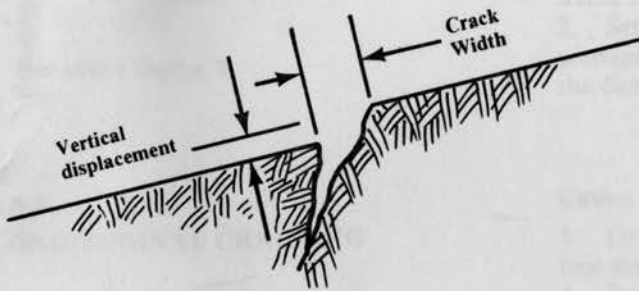

FIGURE 8.2-1

FIGURE 8.2-1 — DISPLACEMENT AT CRACK

**Slides** are easily spotted and require immediate evaluation by the State Engineer's Office. There are, however, early warning signs of a slide. A bulge in the embankment or vertical displacement at a crack in the embankment may indicate sliding.

**Seepage** occurs at all dams in varying degrees. The most potentially dangerous condition is the appearance of seepage on the downstream face above the toe of the dam. Seepage on the downstream slope can lead to a slide or failure of the dam by piping. Refer to Chapter 5 for details concerning seepage.

If these three conditions are identified or suspected, the State Engineer's Office should be notified immediately.

8.3 SPECIAL INSPECTION TECHNIQUES

If the downstream slope is covered with heavy brush or vegetation, a more concentrated search must be made to identify cracks or seepage. A concentration of thick green grass on the slope usually indicates a seepage

area. A crack such as the one shown in the photo below is difficult to locate. To help distinguish drying cracks from other types, the ground surface adjacent to the dam should be examined for similar cracking patterns.



PHOTO 8.3-1 — THREE-FOURTH-INCH-WIDE CRACK, WELL HIDDEN IN GRASS COVER.

Constant vigilance by the owner is necessary in order to identify potentially dangerous situations which threaten the safety and long life of the dam.

8.4 TYPICAL MATERIALS

This information is presented to describe the materials that can be used on the downstream slope.

The two most common materials are unprotected embankment (compacted fill) and rock.

**Embankment** or compacted fill is usually covered with grasses to prevent erosion. An example is shown in the photo below.



PHOTO 8.4-1 — EARLY STAGE OF GROWTH FOR GRASS SLOPE PROTECTION

The fill material is usually from a local source and additional material for making repairs is usually available.

A thick stand of vegetation such as that shown below is not recommended because it obscures visual inspection of the surface.



PHOTO 8.4-2 — UNDESIRABLE AMOUNT OF VEGETATION

Rock is placed on the compacted fill for erosion protection and is the preferred method of protecting the slope from erosion.

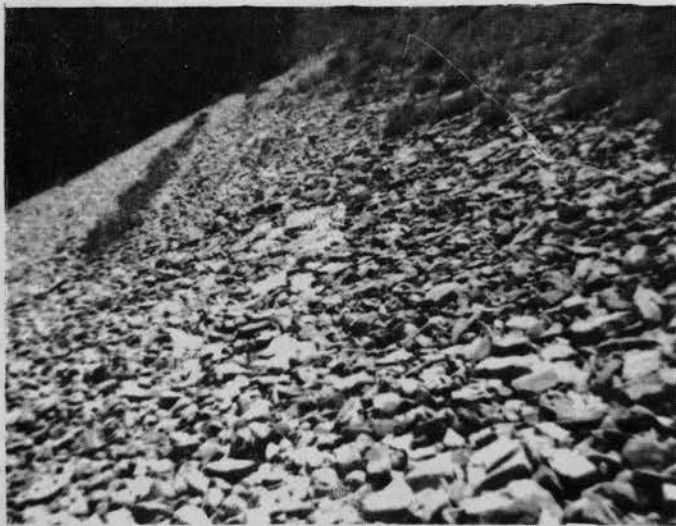

PHOTO 8.4-3 — EXAMPLE OF WELL-PLACED RIPRAP ON THE DOWNSTREAM SLOPE

### 8.5 PROBLEMS FOUND IN THE FIELD

The following charts are presented to help the owner readily identify problems that appear on the downstream slope. The charts also point out the HAZARDOUS problems where evaluation by an ENGINEER IS REQUIRED.

### 8.6 SUMMARY

The downstream slope is especially important during inspection because it is the area where evidence of developing problems appears most frequently. The area requires especially detailed inspection. In order to assure the safety of the dam, it is important to keep this area free from obscuring growth.

When cracks, slides or seepage are noted in this area, the State Engineer's Office should be notified immediately.

## PROBLEM

### 8.5-1 EROSION

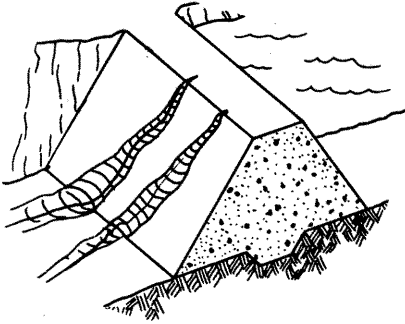

## CAUSES & HARM DONE

### Cause:

Water from intense rainstorms or snow-melt carries surface material down the slope, resulting in continuous troughs.

### Harm:

If allowed to continue, erosion can lead to eventual deterioration of the downstream slope which can shorten the seepage path.

## ACTION REQUIRED

### Action:

1. The preferred method to protect eroded areas is rock or riprap. (See Section 6.4 for information on riprap.)
2. Re-establishing protective grasses can be adequate if the problem is detected early.

### 8.5-2 TRANSVERSE CRACKING

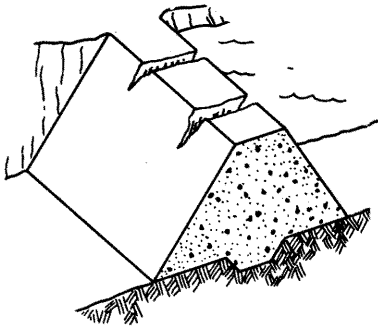

See also Chapter 7.

### Cause:

1. Drying and shrinkage of surface material is most common.
2. Differential settlement of the embankment also leads to transverse cracking (e.g., center settles more than abutments).

### Harm:

1. Shrinkage cracks allow water to enter the embankment. This promotes saturation and increases freeze thaw action.
2. Settlement cracks can lead to seepage of reservoir water through the dam.

### Action:

1. If necessary plug upstream end of crack to prevent flows from the reservoir.
2. A qualified engineer should inspect the conditions and recommend further actions to be taken.

**ENGINEER REQUIRED**

### 8.5-3 LONGITUDINAL CRACKING

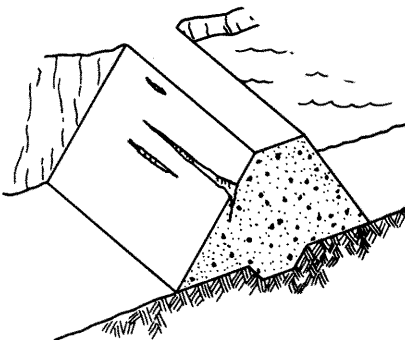

### Cause:

1. Drying and shrinkage of surface material.
2. Downstream movement or settlement of embankment.

### Harm:

1. Can be an early warning of a potential slide.
2. Shrinkage cracks allow water to enter the embankment and freezing will further crack the embankment.
3. Settlement or slide indicating loss of strength in embankment can lead to failure.

### Action:

1. If cracks are from drying, dress area with well-compacted material to keep surface water out and natural moisture in.
2. If cracks are extensive, a qualified engineer should inspect the conditions and recommend further actions to be taken.

**ENGINEER REQUIRED**

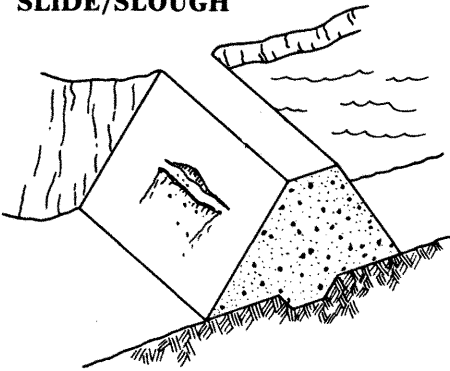
**PROBLEM****8.5-4****SLIDE/SLOUGH****CAUSES & HARM DONE****Cause:**

1. Lack of or loss of strength of embankment material.
2. Loss of strength can be attributed to infiltration of water into the embankment or loss of support by the foundation.

**Harm:**

Can lead to failure of the dam.

**ACTION REQUIRED****Action:****HAZARDOUS**

1. Measure extent and displacement of slide.
2. If continued movement is seen, begin lowering water level until movement stops.
3. Have a qualified engineer inspect the condition and recommend further action.

**ENGINEER REQUIRED**

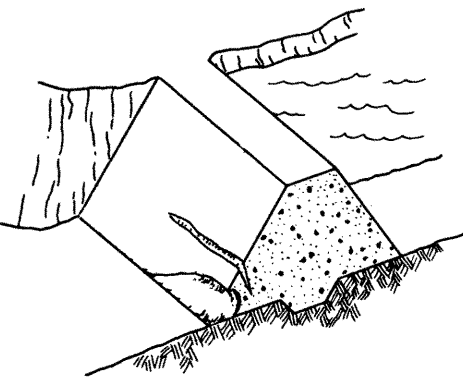
**8.5-5****SLUMP  
(LOCALIZED CONDITION)****Cause:**

Preceded by erosion undercutting a portion of the slope. Can also be found on relatively steep slopes.

**Harm:**

Can expose impervious zone to erosion.

**Action:**

1. Inspect area for seepage.
2. Monitor for progressive failure.
3. Have a qualified engineer inspect the condition and recommend further action.

**ENGINEER REQUIRED**

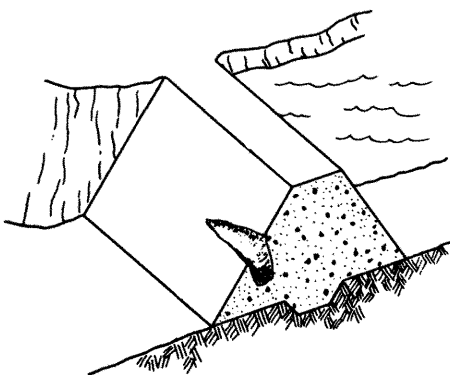
**8.5-6****SINK HOLE/COLLAPSE****Cause:**

Lack of adequate compaction; rodent hole below; piping through embankment or foundation.

**Harm:**

Shortens seepage path, can lead to wash out of embankment.

**Action:**

1. Inspect for and immediately repair rodent holes. Control rodents to prevent future damage.
2. Have a qualified engineer inspect the condition and recommend further action.

**ENGINEER REQUIRED**

**PROBLEM**

8.5-7

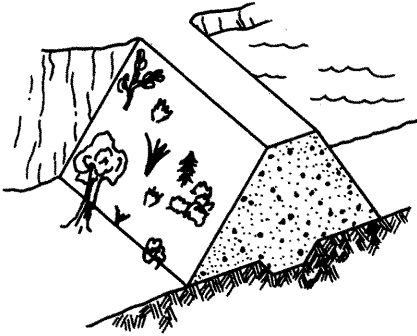
**TREES/OBSCURING BRUSH****CAUSES & HARM DONE****Cause:**

Natural vegetation in area.

**Harm:**

Large tree roots can create seepage paths. Bushes can obscure visual inspection and harbor rodents.

**ACTION REQUIRED****Action:**

1. Remove all large, deep-rooted trees and shrubs on or near the embankment. Properly backfill void. See Chapter 13.
2. Control all other vegetation on the embankment that obscures visual inspection. See Chapter 13.

8.5-8

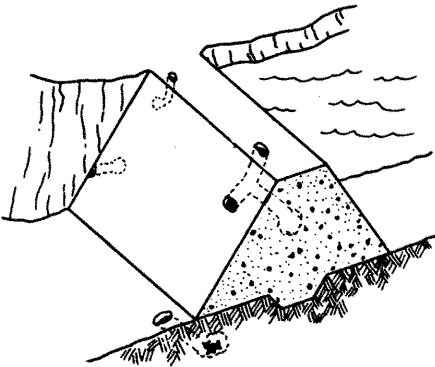
**RODENT ACTIVITY****Cause:**

Over-abundance of rodents.

**Harm:**

Reduces length of seepage path. Can lead to piping failure.

**Action:**

1. Control rodents to prevent additional damage. (See Chapter 13.)
2. Backfill existing rodent holes. (See Chapter 13.)

8.5-9

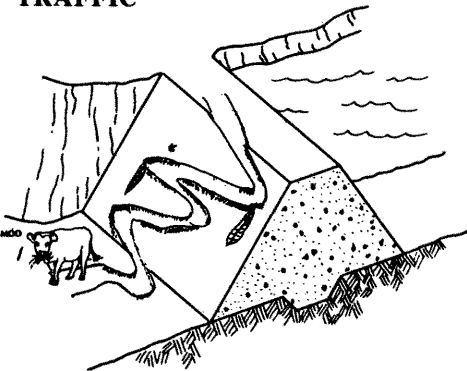
**LIVESTOCK/CATTLE TRAFFIC****Cause:**

Excessive travel by livestock especially harmful to slope when wet.

**Harm:**

Creates areas bare of erosion protection and causes erosion channels. Allows water to stand. Area susceptible to drying cracks.

**Action:**

1. Fence livestock outside embankment area.
2. Repair erosion protection, i.e., riprap, grass.



**PHOTO 8.5-1 — EROSION D/S FACE**

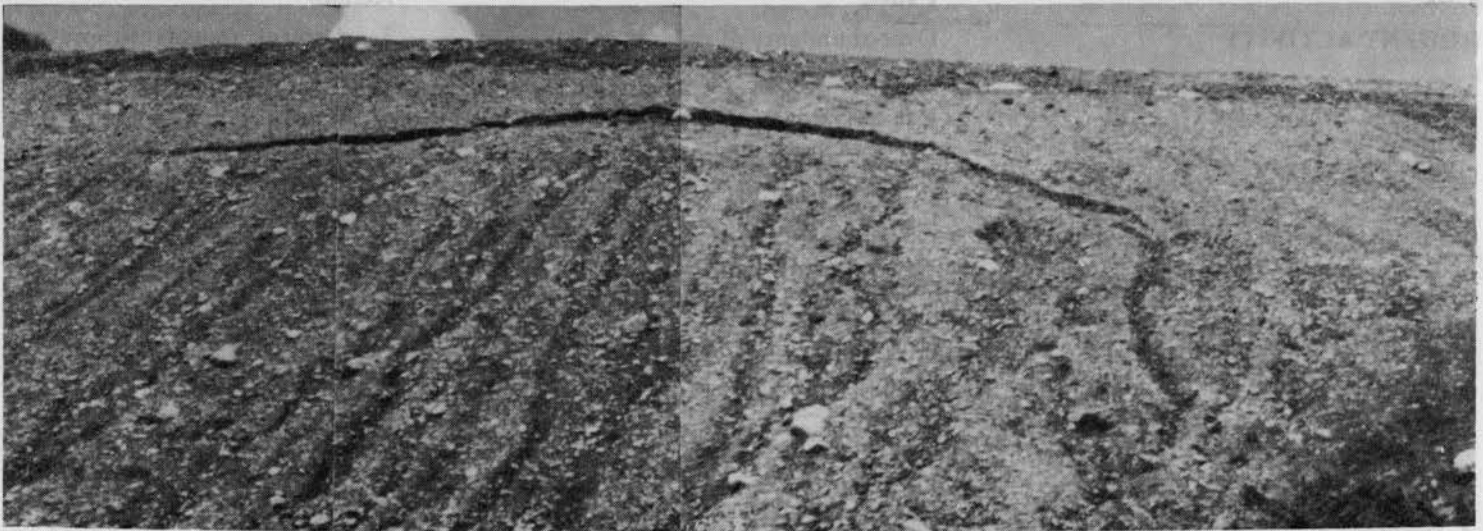

**PHOTO 8.5-2 — TRANSVERSE CRACKING**



**PHOTO 8.5-3 — LONGITUDINAL CRACKING**

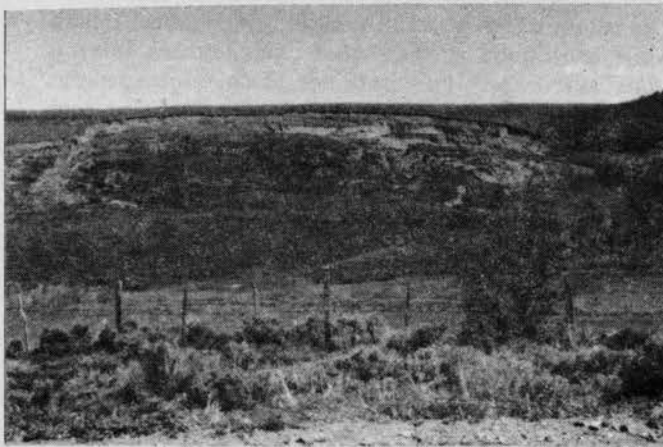

PHOTO 8.5-4 — SLIDE/SLOUGH



PHOTO 8.5-5 — SLUMP



PHOTO 8.5-6 — SINK HOLE/COLLAPSE



PHOTO 8.5-7 — SINK HOLE/COLLAPSE



PHOTO 8.5-8 — SINK HOLE/COLLAPSE

FIGURE 8.5-4 TYPICAL OUTLET CONCENTRATION WITH CONTROL VALVE IN DRY WALL AND DOWNSTREAM RIGID LAYING FLIGHT

The following terminology is discussed with reference to Figures 8.5-1 and 8.5-2.

**Airway Pipe** — A pipe designed to provide air to the draft animals for the purpose of reducing turbulence during release of water. Later the airway is converted to a pipe of similar size (e.g., water) for discharge of "backflow" (Figure 8.5-2).

**Flow Bank** — A concrete bank which supports the outlet water and shields the downstream for the same whenever the water is opened or closed.

**Transect** — A short segment of pipe for outlet water transport and designed to transport flow during emergency operations.

9.1 INTRODUCTION

Now our attention will be concentrated on the Outlet System in order to allow the owners to identify readily conditions that threaten the safety and long life of the dam. Although most of these items can be corrected by normal maintenance, more serious conditions will require inspection by the State Engineer's Office and may require further investigation by an experienced consulting engineer. The items requiring the attention of an engineer will be noted below as "ENGINEER REQUIRED."

9.2 TYPICAL OUTLET CONFIGURATIONS

Basic functions of the outlet were covered in Chapter 3, Section 3.8. The following diagrams are provided to aid the dam owner toward the task of detailed inspection of the outlet system.

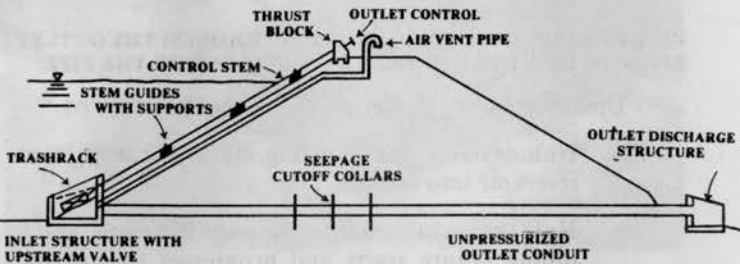

FIGURE 9.2-1 — TYPICAL OUTLET CONFIGURATION WITH UPSTREAM VALVE

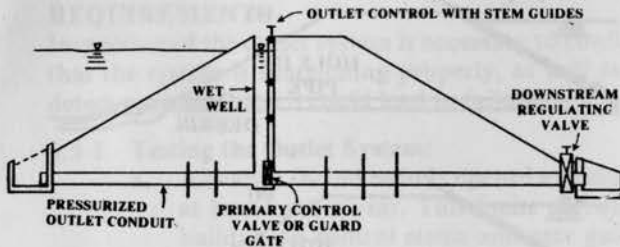

FIGURE 9.2-2 — TYPICAL OUTLET CONFIGURATION WITH CONTROL VALVE IN WET WELL AND DOWNSTREAM REGULATING VALVE

The following terminology is discussed with reference to Figures 9.2-1 and 9.2-2.

**Airvent Pipe** — A pipe designed to provide air to the outlet conduit for the purpose of reducing turbulence during release of water. Extra air is usually necessary downstream of constrictions (e.g., valves). See discussion of "Cavitation," Section 9.3.

**Thrust Block** — A concrete block which supports the outlet control and absorbs the force exerted by the stem whenever the valve is opened or closed.

**Trashrack** — A screen or grating set over the outlet intake structure, and designed to keep debris from entering and clogging the conduit.

**Seepage Cutoff Collar** — A ring of metal or concrete, built around the outside of the outlet conduit. It is designed to limit the flow of seepage water adjacent to the pipe.

**Stilling Basin** — A man-made or natural basin, located at the downstream end of the outlet conduit and designed so outlet releases do not erode the toe of the dam.

9.3 IMPORTANT PRINCIPLES

9.3-1 **Cavitation:** When water flows through an outlet system and passes restrictions (e.g., valves), a pressure drop may occur. If localized water pressures drop below the vapor pressure of water, a partial vacuum is created and the water actually boils, causing cavities of water vapor within the flowing water. These cavities later collapse, causing shockwaves, which can damage the outlet pipe or control valve. This process, called cavitation<sup>1</sup>, can be a serious problem for tall dams where discharge velocities are high. Two typical examples of cavitation damage are shown in photos 9.3-1 and 9.3-2 below.

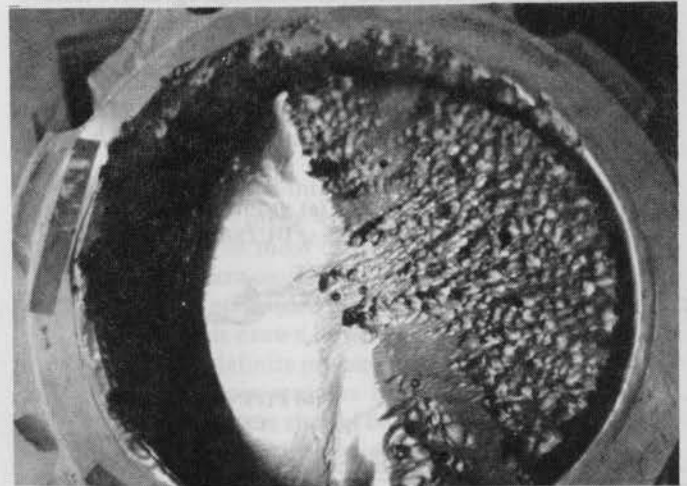

PHOTO 9.3-1 — CAVITATION DAMAGE TO BUTTERFLY VALVE. (Note pock mark pattern on valve leaf.)



PHOTO 9.3-2 — CAVITATION DAMAGE TO STEEL PIPE LINER. Cavitation has eaten through steel to expose concrete behind liner.

<sup>1</sup>Applied Hydraulics in Engineering, Henry M. Morris, p. 251.



Cavitation is reduced by introducing air through a vent pipe at a point downstream of the control valve, where a pressure drop is expected. (See Figure 9.2-1.) The vent pipe establishes atmospheric pressure so that a partial vacuum is not created, and cavitation is avoided.

**9.3-2 Location of Outlet Valve:** Figures 9.2-1 and 9.2-2 show valves at several possible locations along the conduit. The preferred location is at the upstream end. In this configuration the pipe downstream of the valve is not pressurized. Also, the outlet conduit may be dewatered for inspection or repair, and in an emergency involving failure of the conduit. (See Section 9.4.) None of these advantages is present when the valve is located at the downstream end of the conduit, and the pipe is continually pressurized under full reservoir head. If a downstream valve is used for flow regulation, the system should also have a guard gate near its upstream end. (See Figure 9.2-2.)

#### 9.4 ITEMS OF PARTICULAR CONCERN

Figures 9.4-1, 9.4-2, and 9.4-3 show progressive failure of an outlet system by three typical modes. These types of failures are associated with a hole which develops in the conduit, followed by erosion of the surrounding embankment. These conditions require the assistance of an engineer.

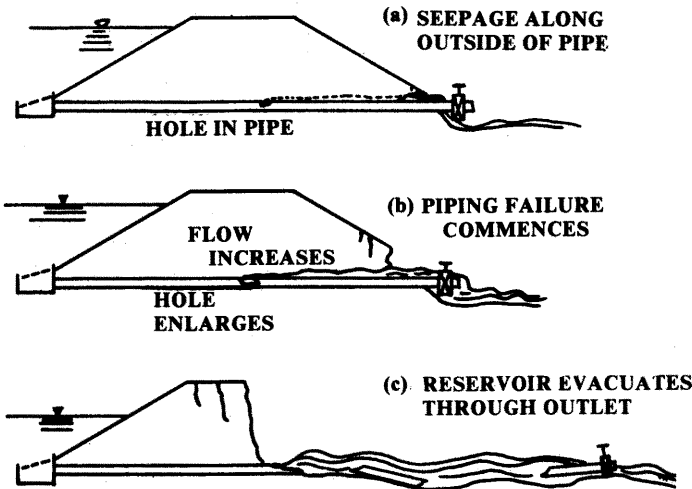

FIGURE 9.4-1 — FAILURE CAUSED BY LEAKAGE ALONG THE OUTSIDE OF THE OUTLET PIPE.

The outlet conduit is pressurized by the downstream valve which has no upstream guard gate.

- Hole develops due to rusting, cavitation, settlement, etc. of conduit. Seepage waters flow out into embankment, and along conduit, to toe of dam.
- Hole in conduit enlarges and seepage increases. A piping failure starts and progresses upstream.
- The piping failure is complete when it reaches the hole in the outlet conduit. The reservoir evacuates, washing away part of the dam and the downstream portion of conduit.

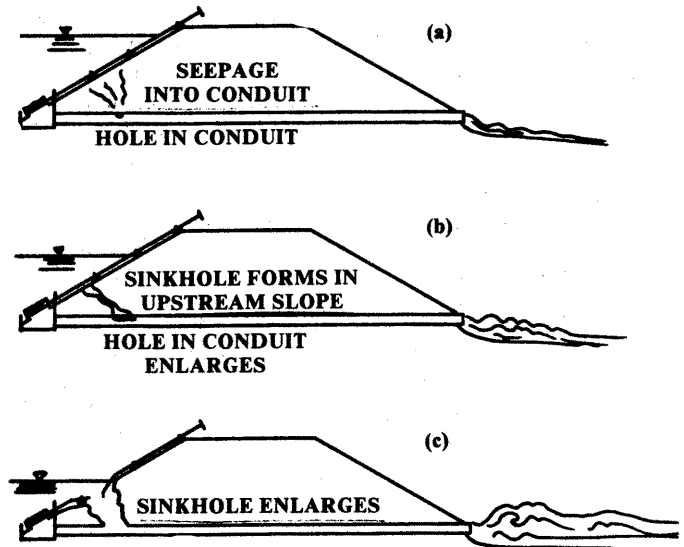

FIGURE 9.4-2 — RESERVOIR EMPTIED THROUGH THE OUTLET BECAUSE OF A HOLE IN THE UPSTREAM END OF THE PIPE.

Upstream valve. Outlet conduit is not pressurized.

- Hole develops due to rusting, etc. Water seeps from reservoir into conduit.
- Hole in conduit enlarges, seepage increases, and a piping failure starts and progresses toward the reservoir. A sinkhole develops on upstream slope.
- Sinkhole enlarges and reservoir evacuates through outlet conduit.

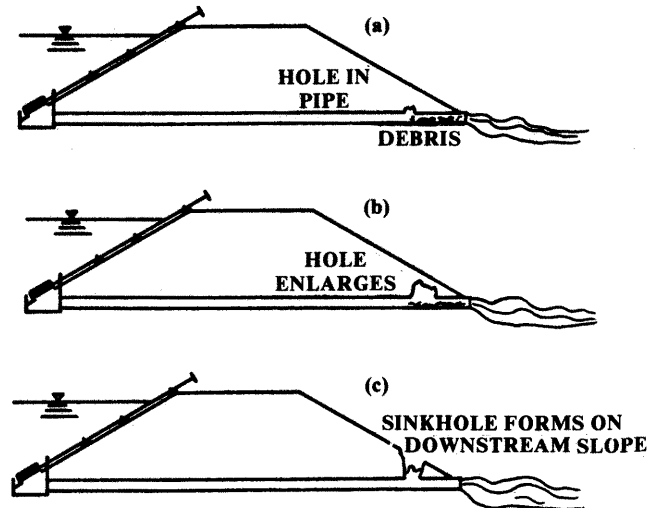

FIGURE 9.4-3 — TURBULENCE AND PRESSURE CREATED BY DEBRIS IN THE PIPE CAUSES SINKHOLE IN THE DOWNSTREAM SLOPE.

Upstream valve. Outlet conduit becomes pressurized because of a buildup of debris in the pipe.

- Hole develops due to rusting, etc. Debris partially blocks conduit, causing water to seep into embankment.
- Hole is enlarged by additional release of water and a cavity develops above pipe. Pumping action of released water slowly erodes embankment.

- c. Cavity collapses, leaving a sinkhole on the downstream slope. Reservoir does **not** evacuate since upstream control valve is undamaged. See Photo 9.4-1.



PHOTO 9.4-1 — SINKHOLE ON DOWNSTREAM SLOPE ABOVE OUTLET CONDUIT. Failure occurred as described in Figure 9.4-3.

## 9.5 SPECIAL INSPECTION TECHNIQUES AND REQUIREMENTS

Inspection of the outlet system is necessary to confirm that the system is functioning properly, as well as to detect problems which could lead to failure.

### 9.5-1 Testing the Outlet System:

- a. All valves should be fully opened and closed at least once a year. This limits corrosion buildup on control stems and gate guides and provides an opportunity to check for smooth operation of the system. Jerky or erratic operation could indicate problems, requiring more detailed inspection.
- b. The system should be checked through the full range of gate settings. Slowly open the valve, checking for noise and vibration. Certain valve settings may result in greater turbulence. Check for noise which sounds like gravel being rapidly transported through the system. This sound indicates that cavitation is occurring. These gate settings should be avoided. (See Section 9.3.)
- c. Check the operation of all mechanical and electrical systems associated with the outlet. Backup electric motors, power generators, and power and lighting wiring should function as intended and be in a safe condition. (See Chapter 13, Sections 13.6, 13.7, and 13.8.)





**9.5-2 Inspection of Outlet System:** Accessible portions of the outlet, such as the outfall structure and control, can be easily and regularly inspected. However, severe problems (Section 9.4) are commonly associated with deterioration or failure of portions of the system which are either buried in the dam or normally under water.

- a. Outlet pipes 30 inches or greater in diameter can be inspected internally, provided the system has an upstream valve, allowing the pipe to be dewatered. Refer to Table 9.8 for conditions to look for. Tapping the conduit interior with a hammer will help locate voids which may exist behind the pipe. This type of inspection should be performed at least once a year.
- b. Small diameter outlet pipes can be inspected by remote TV camera. The camera is moved through the conduit and transmits a picture to an equipment truck, where it can be viewed by a technician. This type inspection is expensive and usually requires the services of an engineer. However, if no other method of inspection is possible, the use of TV equipment is recommended at least once every five years.
- c. Outlet intake structures, wetwells, and outlet pipes with only downstream valves, are the most difficult to inspect because they are usually under water. These should be scheduled for inspection when the reservoir is drawn down or at five year intervals. If a definite problem is suspected, or if the reservoir remains full over extended periods, divers should be hired to perform an underwater inspection.



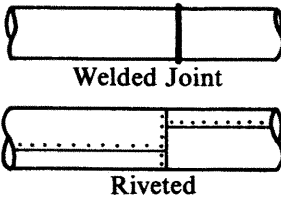
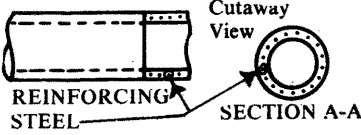

## 9.6 TYPICAL MATERIALS

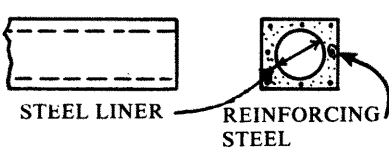
Table 9.6-1 describes materials commonly used for outlet conduits. The information is general and intended to aid the dam owner by identifying potential weaknesses of each material type. For more specific information, refer to footnote references.

**TABLE 9.6-1  
MATERIALS USED IN OUTLET PIPES**

TYPE	DRAWING OR DESCRIPTION	ADVANTAGES	DISADVANTAGES
<b>METAL PIPES</b> 1. CMP (Ref. 1)	Corrugated Metal Pipe 	Low Cost. Light Weight. Flexibility.	Not watertight; can't be used as pressurized pipe. Requires tar protection to inhibit rusting. Subject to structural collapse under high loading. Roughness reduces capacity.
2. CAST IRON (Ref. 2)	Bell and Spigot Joint With Gasket 	Durable. History of satisfactory service commonly exceeds 100 years. Oxides of corrosion adhere and help protect the pipe from further attack. High strength.	Brittle and difficult to weld; cracks if subjected to severe impact or ice action. Tuberculation (formation of rust modules) decreases pipe inside diameter and increases roughness; cement lining usually desirable.
3. DUCTILE IRON (Ref. 2)		High strength with some flexibility; not brittle like cast iron. (Other advantages similar to cast iron.)	Tuberculation. (See Cast Iron.)
4. STEEL (Ref. 1)		High strength and flexibility without cracking. Easily welded for water-tight connection. Forms good liner for concrete encased pipe.	Failure by rusting or chemical attack; oxides flake off, exposing pipe to further attack. Surface protection required.
<b>CONCRETE PIPES</b> 1. RCP (Ref. 3)	Reinforced Concrete Pipe 	High strength. Not subject to corrosion. Rubber gasket joints form watertight connection.	Brittle; can chip or crack if subjected to impact or differential settlement. Heavy; difficult to handle. Subject to erosion by sediment washed through pipe.
2. ACP (Ref. 4)	Asbestos-Cement Pipe  Collar Joint With Gaskets	Will not corrode; contains no metal or organic material. Light weight; easy to install.	Brittle; can be broken by impact or differential settlement.
3. CONCRETE ENCASED PIPE		Adds strength to the steel conduit, by surrounding it with reinforced concrete. If the liner rusts out, outlet can usually be repaired by relining.	Added cost.

**TABLE 9.6-1 (CONTINUED)  
MATERIALS USED IN OUTLET PIPES**

TYPE	DRAWING OR DESCRIPTION	ADVANTAGES	DISADVANTAGES
4. CAST-IN-PLACE CONCRETE CONDUIT	 <p>REINFORCING STEEL</p>	High strength. Any size or shape can be constructed.	Special forming required; added cost.
MISCELLANEOUS MATERIALS	<p>Vitrified Clay Pipe</p>  <p>CUTAWAY VIEW</p> <p>Bell and Spigot, Mortared Joint</p>	Will not corrode. Smooth interior; less resistance to flow.	Brittle; pipe and joints easily damaged by impact or differential settlement. Not normally used as pressure pipe; joints may leak.
1. VCP	<p>Heat Fused Butt Joint</p> 	Flexible and very tough; will not develop stress cracks. Lightweight and will not corrode. Very smooth; little resistance to flow. Watertight.	Limited in-place testing. May collapse or creep under high loading; concrete encasement may be required.
2. POLYETHYLENE (Ref. 5)	<p>Glued Collar Joint</p> 	Lightweight and inexpensive. Easy assembly; no special tools. Smooth and will not corrode.	Limited in-place testing. May "sunburn" and become brittle if exposed to sunlight for extended periods.
4. WOOD STAVE	<p>Steel Bands</p> 	Will not rust. Smooth and not damaged by freezing. Lightweight.	Relatively short life unless kept saturated. High cost of maintenance. Seldom used in current design. High leakage; low strength.

- REFERENCES: 1. *Corrugated Metal Pipe, Catalog C-1B*, Thompson Pipe & Steel Co., Denver, CO.  
 2. *Handbook of Cast Iron Pipe*. 3rd Ed.. Cast Iron Pipe Research Association.  
 3. *Engineering Manual*, Lock Joint Concrete Pressure Pipe, Interpace Corporation.  
 4. *Sewer Pipe Manual*. Johns-Manville.  
 5. *Driscopipe 7600*, Phillips Products Co., Inc.  
 6. *Water Supply and Sewage*, by Steel, pp. 114-115.

### 9.7 TYPES OF OUTLET VALVES

Table 9.7-1 shows several specific types of valves, with the intent of aiding the dam owner in inspection of his outlet. Valves can be generally classified based upon their intended function as follows:

**Guard Gate:** A valve located at or near the upstream end of the pipe and maintained in the fully open position. The valve may be closed to dewater the conduit for inspection, maintenance, or in an emergency involving failure of the outlet system. (See Section 9.4.) The guard gate is designed to be either fully open or fully closed. It should not be used as a regulating valve.

**Regulating Valve:** A valve used to adjust the rate of water release. It may be located at any point along the conduit, but must function well under the full range of valve settings. For most dams, an airvent is required just downstream of this valve to reduce turbulence and cavitation. (See Section 9.3.)

**Free Discharge Valve:** A regulating valve, located at the downstream end of the outlet pipe and designed to discharge directly into the air.

**TABLE 9.7-1  
OUTLET VALVES**

**TYPE**

SLIDE GATE  
OR  
SLUICE GATE  
(Ref. 2)

**DRAWING OR DESCRIPTION**

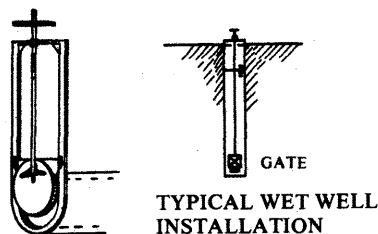

**USES AND DISCUSSION**

The most common type of valve. Used as regulating or guard valve at upstream end of outlet pipe, or in wet well. Mechanically simple and available in a variety of sizes and shapes. Suitable for dams of low to moderate height. If used to regulate flow, an airvent is recommended just downstream of the valve.

GATE VALVE  
(Ref. 1)

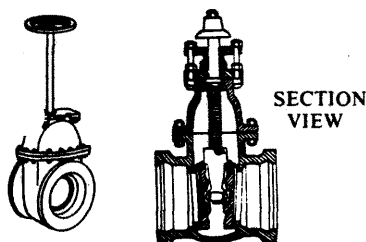

Typically used as a regulating valve or guard valve at the upstream end of the conduit or in an outlet well. Since the valve is watertight, the outlet well remains dry. The gate leaf is wedge-shaped and seals into a tapered seat.

If a gate valve is used for regulation, an airvent is recommended just downstream of the valve.

BUTTERFLY VALVE  
(Ref. 2)

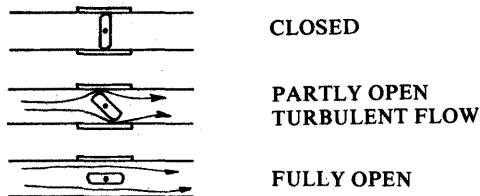

Performs best as an upstream guard gate. If used for regulation, certain valve openings cause turbulence and cavitation. Airvent required downstream of valve, if used for regulation.

BALL VALVE,  
PLUG VALVE,  
OR CONE VALVE.  
(Ref. 1)

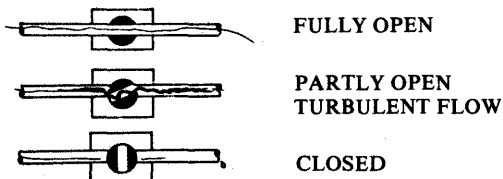

Used in low head situations or as a guard valve. Intermediate valve settings may result in turbulence and cavitation (airvent recommended).

FREE DISCHARGE VALVE  
(HOWELL-BUNGER,  
OR  
HOLLOW JET)  
(Ref. 3)

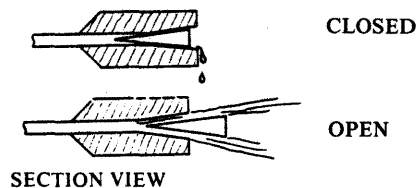

Located at downstream end of outlet conduit, discharging into the air (free discharge). Excellent regulating valve; functions well in a wide range of release rates. Used primarily on high dams where outlet pressures are great. Upstream guard gate required.

FLAP GATE  
(Ref. 2)  
SHEAR GATE  
(Ref. 1)

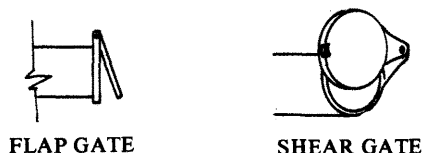





Used as guard gate at upstream end of outlet conduit. Normally in the fully open position. Valve is closed only to dewater the outlet conduit for maintenance, inspection, or in an emergency.

- REFERENCES: 1. *Water Supply and Sewage*, by Steel, pp. 152-153.  
2. *Waterman Catalog*.  
3. *Handbook of Dam Engineering*, p. 538.

## 9.8 FIELD CONDITIONS TO LOOK FOR

Table 9.8 describes specific conditions which may be found during an inspection of the outlet system. The dam owner should use this information in conjunction with the diagrams and discussion in Section 9.5. If serious conditions similar to those described in Section 9.4 are discovered, engineering assistance should be obtained.

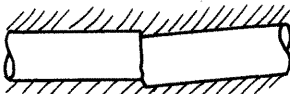
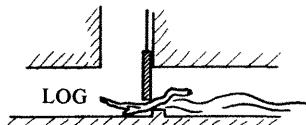
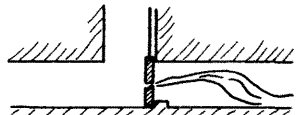
**TABLE 9.8 — OUTLET INSPECTION — SPECIFIC ITEMS TO LOOK FOR**

<b>CONDITION FOUND</b>	<b>CAUSES &amp; HARM DONE</b>	<b>ACTION REQUIRED</b>
<p>9.8-1 <b>OUTLET PIPE DAMAGE</b></p>  <p>CRACK</p>	<p><b>Cause:</b> Settlement; impact. (See Photo 9.8-2.)</p>	<p><b>For all conditions:</b> Check for evidence of water either entering or exiting pipe at crack/hole/etc.</p>
 <p>HOLE</p>	<p><b>Cause:</b> Rust (steel pipe) Erosion (concrete pipe) Cavitation (See Photo 9.8-1.)</p>	<p>Tap pipe in vicinity of damaged area, listening for hollow sound which indicates a void has formed along the outside of the conduit.</p>
 <p>JOINT OFFSET</p>	<p><b>Cause:</b> Settlement or poor construction practice.</p> <p><b>Harm:</b> Provides passageway for water to exit or enter pipe. (Refer to Section 9.4.)</p>	<p>If a progressive failure similar to those shown in Section 9.4 is suspected, request engineering assistance.</p>
<p>9.8-2 <b>VALVE LEAKAGE</b> <b>DEBRIS STUCK UNDER GATE</b></p>	<p><b>Cause:</b> Trashrack missing or damaged.</p>	<p>Raise and lower gate slowly until debris is loosened and floats past valve. When reservoir is lowered, repair or replace trashrack.</p>
 <p>LOG</p>	<p><b>Harm:</b> Gate will not close. Gate or stem may be damaged in effort to close gate.</p>	
<p><b>CRACKED GATE LEAF</b></p> 	<p><b>Cause:</b> Ice action, rust, impact, vibration, or stress resulting from forcing gate closed when it is jammed.</p>	<p>Use valve only in fully open or closed position. Minimize use of valve until leaf can be repaired or replaced.</p>
<p><b>Harm:</b> Gate-leaf may fail completely, evacuating reservoir.</p>		
<p><b>DAMAGED GATE SEAT OR GUIDES</b></p>	<p><b>Cause:</b> Rust, erosion, cavitation, vibration, or wear.</p>	<p>Minimize use of valve until guides/seats can be repaired. If cavitation is the cause, check to see if air vent pipe exists, and is unobstructed. (See Photo 9.8-3.)</p>
 <p>AIRVENT</p>	<p><b>Harm:</b> Leakage and loss of support for gate leaf. Gate may bind in guides and become inoperable.</p>	

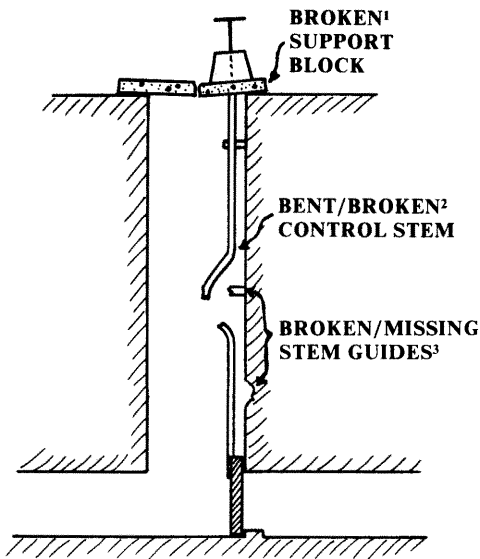
**TABLE 9.8 — OUTLET INSPECTION — SPECIFIC ITEMS TO LOOK FOR (CONTINUED)****CONDITION FOUND****9.8-3 CONTROL WORKS****CAUSES & HARM DONE****1. BROKEN SUPPORT BLOCK:****Cause:**

Concrete deterioration.  
Excessive force exerted on control stem by attempting to open gate when it was jammed.

**Harm:**

Causes control support block to tilt; control stem may bind. Control headworks may settle. Gate may not open all the way. Support block may fail completely, leaving outlet inoperable.

**2. BENT/BROKEN CONTROL STEM:****Cause:**

Rust. Excess force used to open or close gate. Inadequate or broken stem guides.

**Harm:**

Outlet is inoperable.

**3. BROKEN/MISSING STEM GUIDES:****Cause:**

Rust. Inadequate lubrication. Excess force used to open or close gate when it was jammed.

**Harm:**

Loss of support for control stem. Stem may buckle and break under even normal use, (as in this example).

**ACTION REQUIRED**

Any of these conditions can mean the control is either inoperable or at best partially operable. Use of the system should be minimized or discontinued. If the outlet system has a second control valve, consider using it to regulate releases until repairs can be made. (Refer to Chapter 13.6, operating gates, maintenance.) Engineering assistance is recommended.

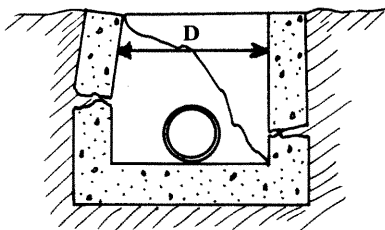
**9.8-4****FAILURE OF CONCRETE OUTFALL STRUCTURE****Cause:**

Excessive side pressures on nonreinforced concrete structure. Poor concrete quality.

**Harm:**

Loss of outfall structure exposes embankment to erosion by outlet releases.

Check for progressive failure by monitoring typical dimension, such as "d" shown in figure.

Repair by patching cracks and providing drainage around concrete structure. Total replacement of outfall structure may be required.

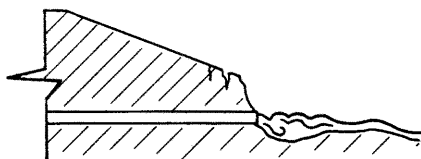
**9.8-5****OUTLET RELEASES ERODING TOE OF DAM****Cause:**

Outlet pipe too short. Lack of energy-dissipating pool or structure at downstream end of conduit.

**Harm:**

Erosion of toe oversteepens downstream slope, causing progressive sloughing.

Extend pipe beyond toe (use a pipe of same size and material, and form watertight connection to existing conduit).

Protect embankment with riprap over suitable bedding.

## 9.9 SUMMARY

Proper inspection of the outlet usually requires advance planning to allow outflows to be shut off and inundated areas to be pumped out. Inspection by the owner's representative can usually determine if a problem exists with the outlet. In most cases an experienced engineer will be required to recommend corrective action when problems are found. The State Engineer's Office should be notified when outlet inspections are planned to allow it to schedule its participation. The engineer may be able to advise the owner of prudent maintenance or repairs.

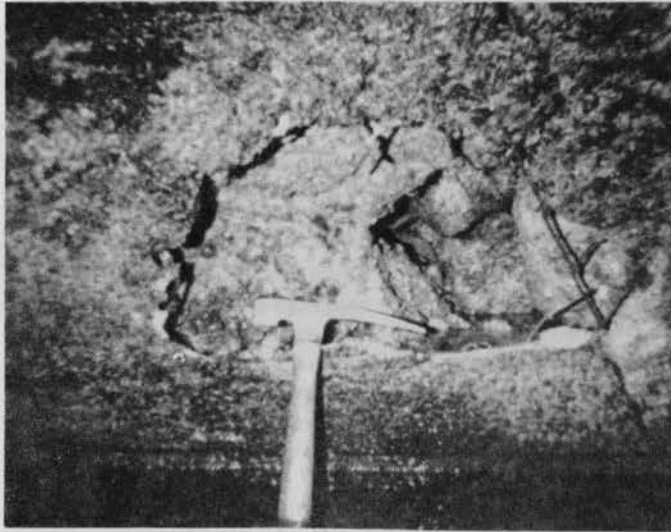

**PHOTO 9.8-1 — OUTLET — INTERNAL EROSION**  
Hole in cast-in-place concrete lining, caused by turbulence and erosion.

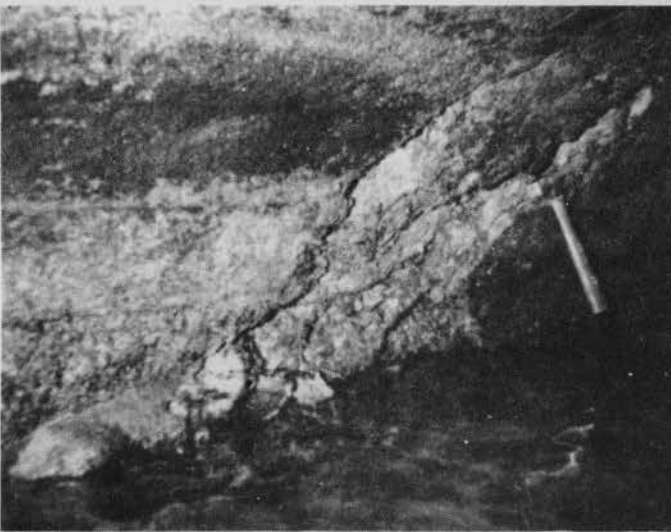

**PHOTO 9.8-2 — OUTLET DETERIORATION**  
Crack in cast-in-place concrete lining. Settlement may have been responsible. Note tree roots entering tunnel, lower left of photo.

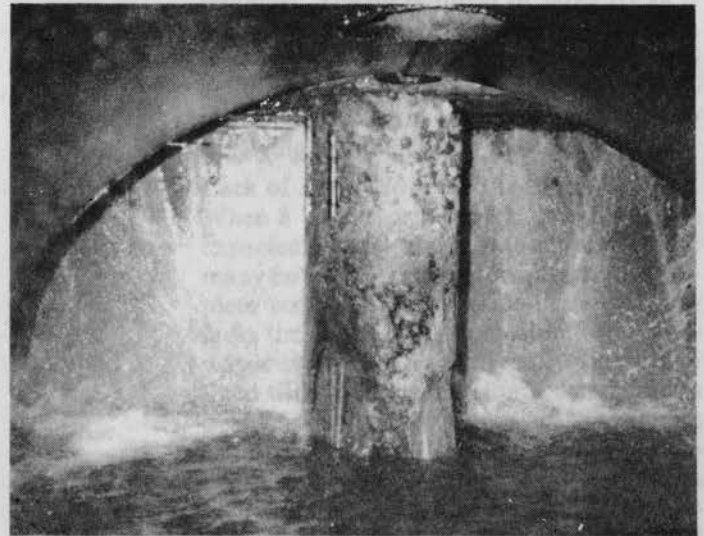

**PHOTO 9.8-3 — SIDE BY SIDE SLIDE GATES**  
Gate leakage and cavitation damage to bull nose pier. Note exposed reinforcing steel. Air vent pipe at top of photo.

A spillway cannot be expected to perform properly if it is deteriorated. Deterioration includes collapse of side slopes, weathering of material, disintegration of grout, breakdown of concrete lining, erosion of approach section, sloughing of chute channel, excessive siltation of stilling basin or discharge channel, and loss of protective grass cover. These can lead to flows under and around the protective material which can cause severe erosion. Remedial actions must be taken as soon as any sign of deterioration has been detected, even during storm flow.

### 9.2.4 Cracks

Drying cracks in an earth spillway channel are usually not regarded as a functional problem. Missing rocks in a riprap lining can be considered as a "crack" in the protective cover, and this must be repaired as soon.

Cracks in concrete lining are normally encountered in the spillway channel. The cracks may be caused by uneven foundation settlement, slab displacement, by excessive earth or water pressure. Large cracks will allow water to wash out fine material from or behind the concrete slab, causing spalls.



## 10.1 INTRODUCTION

The main function of a spillway is to provide a safe evacuation route for excess water that has entered the reservoir after a large storm or rapid snow-melt. If the spillway is of inadequate size the dam can overtop. Overtopping is the main cause of dam failure. Defects in the spillway can cause the dam to fail by rapid erosion produced by floodwater. Figure 10.1 shows the sketch of a typical spillway.

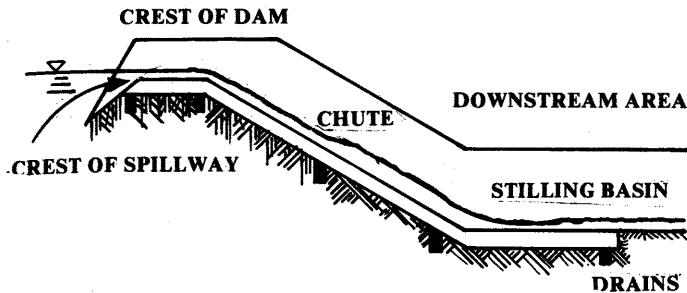

FIGURE 10.1  
PROFILE OF A TYPICAL SPILLWAY

Required spillway capacity is determined by several factors, such as drainage area, magnitude or intensity of the storm, storage capacity of the reservoir, the speed with which rain water would flow into the reservoir, and how rapidly water would build up in the reservoir. A spillway which is too small will cause the water surface in the reservoir to rise above the crest of the dam. When the dam site is hit by a large storm, overtopping of the dam will usually create severe damage to the dam or the dam foundation, especially in the case of an earth dam. If the over-flow or overtopping persists for some time, the dam can erode away and fail.

This potential danger is **not** widely understood because large storms tend to have a low frequency of occurrence. Sometimes a dam owner will say, "It never rained like that in this area." But an owner never knows when that big storm will happen at his dam site. Nobody anticipated the Big Thompson flood of July 31, 1976. But suddenly it became a tragic fact. Ten inches of rain fell in a matter of five hours in some areas. The resulting flood killed 139 persons with 5 persons still missing.

The main purpose of this chapter is to identify common problems associated with spillway structures, outline procedures of spillway inspection, and suggest remedial actions for problems identified during the inspection.

## 10.2 IMPORTANT PROBLEMS

There are four major types of problems that can prevent a spillway from functioning properly. As soon as any of these problems is identified, remedial steps must be taken to correct the defect.

### 10.2-1 Obstruction

The spillway channel may be obstructed by excessive growth of grass and weeds, thick brush, trees, debris, or landslide deposits. An obstructed spillway will have a substantially reduced discharge capacity. This reduced capacity can create serious problems, including overtopping of the dam.

Grass is usually not considered as an obstruction. But tall weeds and brush should be periodically cleared and trees removed as soon as they are noticed. Brush and debris can be entangled with trees to form an effective obstruction. When this happens, an even and smooth flow pattern cannot be maintained. Consequently, flow capacity of the spillway will be reduced.

Any substantial amount of dirt deposited in the spillway channel from sloughing, landslide above the channel, or sediment transport into the area must be immediately removed. Timely removal of large rocks in the channel would obstruct flow and encourage erosion. Their sudden plunge to the stilling basin also results in abrasion of the channel lining and damage to the stilling basin.

### 10.2-2 Lack of Ability to Resist Erosion

When a large storm occurs, the spillway is expected to carry a large amount of water for many hours. Severe erosion damage or complete wash-out could result if the spillway lacks the ability to resist erosion. If the spillway is excavated in a hard rock formation or lined with concrete, erosion is usually not a problem. But if the spillway is excavated in sandy, deteriorated granite, clay, or silt deposits, erosion protection is very important. Generally, resistance to erosion can be increased if the spillway channel has a mild slope, or if it is covered with a layer of grass or riprap with bedding material.

### 10.2-3 Deterioration

A spillway cannot be expected to perform properly if it is deteriorated. Deterioration includes collapse of side slopes, weathering of material, disintegration of riprap, breakdown of concrete lining, erosion of approach section, sloughing of chute channel, excessive siltation of stilling basin or discharge channel, and loss of protective grass cover. These can lead to flows under and around the protective material which can cause severe erosion. Remedial actions must be taken as soon as any sign of deterioration has been detected, even during storm flows.

### 10.2-4 Cracks

Drying cracks in an earth spillway channel are usually not regarded as a functional problem. Missing rocks in a riprap lining can be considered as a "crack" in the protective cover, and this must be repaired at once.

Cracks in concrete lining are commonly encountered in the spillway channel. The cracks may be caused by uneven foundation settlement, slab displacement, or excessive earth or water pressure. Large cracks will allow water to wash out fine materials below or behind the concrete slab, causing erosion

and leading to more cracks. An extensive crack can cause the concrete slab to be severely displaced. Consequently, the slab may be dislodged and washed away by the flow. A severely cracked concrete spillway should be examined by and repaired under the supervision of an engineer.

### 10.3 COMMONLY USED MATERIALS

**Earth** — An emergency spillway may be dug in natural earth and left unlined if the flow velocity is not expected to be higher than 5 feet per second. Cohesive type soil or tough clay is preferred because it affords greater resistance to erosion. Measures should be taken to encourage an even growth of grass over the spillway because it provides more protection against erosion. Side slopes should be made as mild as possible to minimize any chance of slope failure.

**Earth with Control Sill** — It is sometimes desirable to construct a control sill across the spillway channel. The sill is essentially a concrete wall buried deep in the channel. The wall is usually perpendicular to the direction of flow, and its crest or the top surface is supposed to be horizontal (or level) and flush with the channel surface. The sill serves as a control section at which discharge may be measured. In the case of a flood, the sill will evenly distribute the flow across the channel, thus minimizing erosion of the downstream portion. The sill will also halt backcutting to assure that the upstream portion of the channel will not be damaged by erosion. The area downstream of the sill may be protected with riprap.

**Riprap with Bedding Material** — Riprap is a layer of randomly sized rocks carefully placed to protect underlying soils. Riprap protection is one of the most economical ways to protect an earth spillway against erosion, provided that good quality rock is readily available. Adequate depth of riprap protection is required at the entrance section, chute bottom, and banks, and the stilling basin. In order to prevent earth particles under the riprap from being washed away, a layer of bedding material should be evenly spread over the channel bottom or side slope before the riprap is placed. See Chapter 13 for more details about the construction and maintenance of bedding material and riprap.

**Concrete** — Concrete, especially (steel bar) reinforced concrete, is one of the most commonly used materials for spillways. A concrete spillway can be expected to last many decades. During construction, sound aggregates must be used, and the concrete properly mixed and carefully cured. Addition of air-entraining agents to the mixing of concrete will render the concrete more resistant to the harmful effect of freeze-thaw cycles. Construction joints and expansion joints are usually present at suitable intervals to prevent fracturing or shrinkage cracks. The joint must be filled with sealants. Adjacent concrete panels or slabs are constructed flush relative to each other at the joint to avoid uplift pressure or erosion caused by flowing water. Adequate reinforcing steel

bars must be used to prevent large cracks and failure. Weep holes and underdrainage systems are installed to avoid build-up of water pressure.

A concrete spillway should be designed by and constructed under the supervision of a professional engineer.

**Wood** — In a relatively small structure, wood piles may be used to provide protection to toe areas and foundation at the spillway. Occasionally, wood planks are used to construct a large flume serving as a spillway.

Since wood material decays easily, it is not recommended for permanent purposes above the water surface. Wood piles submerged below water all the time, however, can be expected to last a long time. Specially treated wood will also last longer than untreated material.

### 10.4 PROCEDURE FOR INSPECTION

Spillway inspection is an important part of a dam safety program. The basic objective of spillway inspection is to detect any sign of obstruction, erosion, deterioration, misalignment, or cracks. Identification of obstruction is relatively simple. Inspection procedures regarding erosion resistance, deterioration, and cracks are briefly outlined below according to the spillway type.

#### 10.4-1 Earth Spillway and Earth with Control Sill

When inspecting an earth spillway, find out whether side slopes have sloughed, or whether there is an excessive vegetative growth in the channel. Look for signs of erosion and rodent activities. Use a probe to obtain a comparative feel of the hardness and moisture content of the soil. Note location of particularly wet or soft spots. See if the stilling basin or drop structure is properly protected with rocks or riprap. Since some erosion is unavoidable during spilling, determine whether such erosion might endanger the embankment itself. If the spillway is installed with a sill, determine if there is any crack or misalignment of the sill. Also look for any erosion beneath or downstream of the sill.

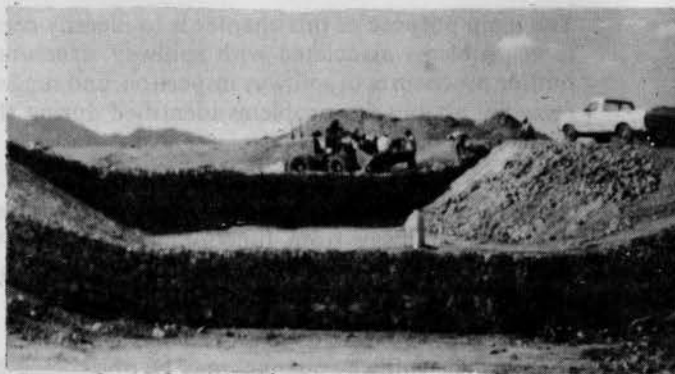

PHOTO 10.4-1 — GABION DROP STRUCTURE. A special type of rock protection against erosion.

### 10.4-2 Concrete Spillway

Commonly encountered defects and general inspection procedures for concrete spillway are outlined as follows:

- a. Cracks — Hairline cracks are usually harmless. Large cracks should be carefully inspected. Note the location, width, length, and orientation of the crack. Determine if concrete around the crack has deteriorated or whether reinforcing bars are exposed.
- b. Spalling — Spillway surfaces exposed to freeze-thaw cycles often suffer from surface spalling. Chemical action, contamination, and unsound aggregates can also cause spalling. If spalling is extensive, draw a sketch of the spalled area and show the length, width, and depth of the area. Examine closely to see if the remaining concrete has deteriorated or reinforcing bars are exposed. Tap the concrete with a "bonker" or rock hammer to see if there is empty space below the surface. Shallow spalling should be examined from time to time to see if it is getting worse. Deep spalling must be repaired by an experienced person as soon as possible.

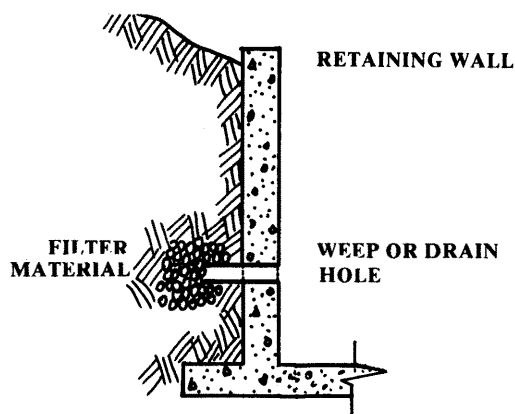

FIGURE 10.2 — WEEP HOLE

- c. Drains — Walls of spillway are usually equipped with weep (or drain) holes. Occasionally, spillway chute slabs are also equipped with weep holes. If all holes are dry, it is probably because the soil behind the wall or below the slab is dry. If some holes are draining while others are dry, then perhaps the dry holes are plugged by mud or mineral deposits. Probe the plugged hole to determine probable causes of the blockage. Plugged weep holes increase chances for failure of the retaining wall or chute slab. Try to clean out dirt or deposit and restore draining ability. If this does not work, rehabilitation work must be performed under the supervision of a professional engineer as soon as possible.

- d. Joints — Spillway retaining walls and chute slabs are normally constructed in sections. Between adjoining sections, gaps or joints must be tightly sealed with flexible materials such as tar, epoxies, or other chemical compounds. Sometimes rubber or plastic diaphragm or copper foil is used to seal the joint watertight. During inspection, note the location, length, and depth of any missing sealant. Also, probe the open gap and determine if soil behind the wall or below the slab has been undermined.
- e. Misalignment — Spillway retaining walls or chute slabs may be displaced from their original position by foundation settlement or earth or water pressure. Sight carefully at the upstream or downstream end of the spillway near the wall to determine if it has been tipped inward or outward. Relative displacement or offset between neighboring sections can be readily identified at the joint. Measure the horizontal as well as vertical displacement as explained in Section 12.5-2.3. A fence line on top of the retaining wall is usually erected in a straight line at the time of construction. Any curve or distortion of the fence line may indicate that the wall has deformed.

At the time of construction, the entire spillway chute is supposed to form a smooth surface. Measurement of relative movement between neighboring chute slabs at the joint will give a good indication of the slab displacement.

Misalignment or displacement of the wall or the slab is often associated with cracks. A clear description of crack patterns should be recorded or photos taken to help in understanding the nature of the displacement.

- 10.5 **COMMONLY ENCOUNTERED PROBLEMS AND ACTIONS REQUIRED** — The following chart is a list of problems frequently encountered when inspecting a spillway. Probable causes of each problem are presented along with recommended remedial actions.

### 10.6 SUMMARY

The spillway is a very important part of a dam. If it is not designed with adequate capacity or constructed and maintained properly, overtopping of the embankment may occur during a large storm, resulting in failure of the dam and serious damage to downstream properties, or even death of downstream residents.

A spillway should always be kept free of obstruction, have the ability to resist erosion, and be protected from deterioration. It should be emphasized that a dam and reservoir represent not only a potential public hazard, but also a substantial investment. The dam's owner can identify any changes in previously

noted conditions that indicate a safety problem. A conscientious annual maintenance program will address and control most of the conditions identified above. When a questionable condition is found, the

State Engineer's Office should be notified immediately. Quick corrective reaction to conditions requiring attention will promote the safety and long life of the dam and possibly prevent costly future repairs.

## CONDITION FOUND

### 10.5-1

#### Debris or other obstructions

##### WEED AND BRUSH



## CAUSES & HARM DONE

### Cause:

Accumulation of slide materials, dead trees, excessive vegetative growth, etc., in spillway channel.

### Harm:

Reduced discharge capacity; overflow of spillway; overtopping of dam. Prolonged overtopping can cause failure of the dam.

## ACTION REQUIRED

### Action:

Clean out debris periodically; control vegetative growth in spillway channel. Install log boom in front of spillway entrance to intercept debris.

### 10.5-2

#### Excessive erosion in earth-slide causes concentrated flows

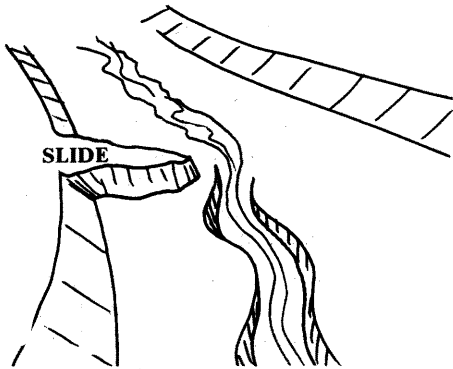

### Cause:

Discharge velocity too high; bottom and slope material loose or deteriorated; channel and bank slopes too steep; bare soil unprotected; poor construction; protective surface failed.

### Harm:

Disturbed flow pattern; loss of material, increased sediment load downstream; collapse of banks; failure of spillway; can lead to rapid evacuation of the reservoir through the severely eroded spillway.

### Action:

Minimize flow velocity by proper design. Use sound material. Keep channel and bank slopes mild. Encourage growth of grass on soil surface. Construct smooth and well-compacted surfaces. Protect surface with riprap, asphalt, or concrete. Repair eroded portion using sound construction practices.

### 10.5-3

#### End of spillway chute undercut

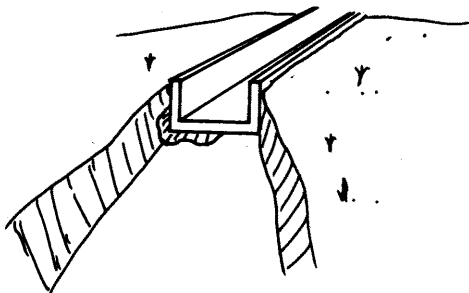

### Cause:

Poor configuration of stilling basin area. Highly erodible materials. Absence of cutoff wall at end of chute.

### Harm:

Structural damage to spillway structure; collapse of slab and wall; leads to costly repair.

### Action:

Dewater affected area; clean out eroded area and properly backfill. Improve stream channel below chute; provide properly sized riprap in stilling basin area. Install cutoff wall.

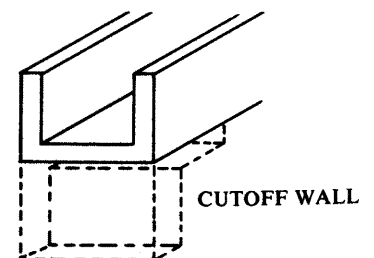

**CONDITION FOUND**

10.5-4

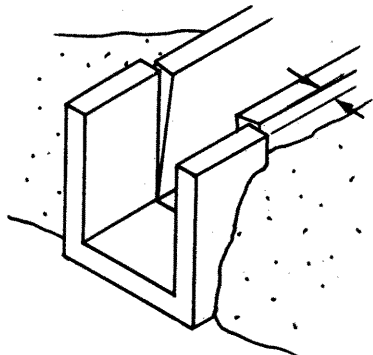
**Wall displacement****CAUSES & HARM DONE****Cause:**

Poor workmanship; uneven settlement of foundation; excessive earth and water pressure; insufficient steel bar reinforcement of concrete.

**Harm:**

Minor displacement will create eddies and turbulence in the flow, causing erosion of the soil behind the wall. Major displacement will cause severe cracks and eventual failure of the structure.

**ACTION REQUIRED****Action:**

Reconstruction should be done according to sound engineering practices. Foundation should be carefully prepared. Adequate weep holes should be installed to relieve water pressure behind wall. Use sufficient reinforcement in the concrete. Anchor walls to prevent further displacement. Install struts between spillway walls is required. Clean out and backflush drains to assure proper operations. Consult an engineer before actions are taken.

**ENGINEER REQUIRED**

10.5-5

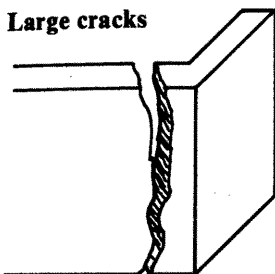
**Large cracks****Cause:**

Construction defect; local concentrated stress; local material deterioration; foundation failure, excessive backfill pressure.

**Harm:**

Disturbance in flow patterns; erosion of foundation and backfill; eventual collapse of structure.

**Action:**

Large cracks without large displacement should be repaired by patching. Surrounding areas should be cleaned or cut out before patching material is applied. (See Chapter 13.) Installation of weep holes or other actions may be needed.

10.5-6

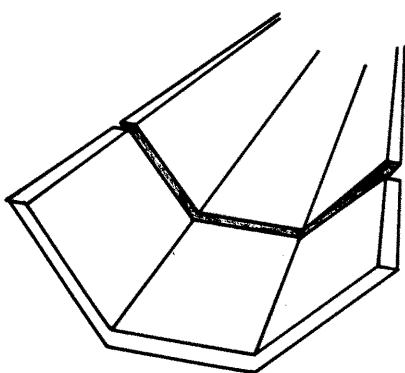
**Open or displaced joints****Cause:**

Excessive and uneven settlement of foundation; sliding of concrete slab; construction joint too wide and left unsealed. Sealant deteriorated and washed away.

**Harm:**

Erosion of foundation material may weaken support and cause further cracks; pressure induced by water flowing over displaced joints may wash away wall or slab, or cause extensive undermining.

**Action:**

Construction joint should be no wider than 1/2 inch. All joints should be sealed with asphalt or other flexible materials. Waterstops should be used where feasible. Clean the joint, replace eroded materials, and seal the joint. Foundation should be properly drained and prepared. Underside of chute slabs should have ribs of sufficient depth to prevent sliding. Avoid steep chute slope.

**ENGINEER REQUIRED**

## CONDITION FOUND

10.5-7

**Breakdown or loss of riprap**

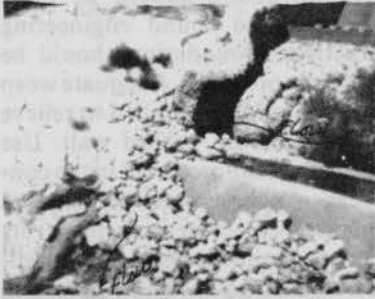

PHOTO 10.5-1 — FAILED SPILLWAY GABION WALL

10.5-8

**Material deterioration-spalling and disintegration of riprap, concrete, etc.**



PHOTO 10.5-1 — DETERIORATION OF RIGHT D/S WINGWALL OF SPILLWAY.

10.5-9

**Poor surface drainage**



PHOTO 10.5-3 — WATER EXITING AT JOINT OR CRACK BECAUSE OF POOR DRAINAGE.

## CAUSES & HARM DONE

### Cause:

Slope too steep; material poorly graded; failure of subgrade; flow velocity too high; improper placement of material; bedding material or foundation washed away.

### Harm:

Erosion of channel bottom and banks; failure of spillway.

### Cause:

Use of unsound or defective materials; structure subjected to freeze-thaw cycles; improper maintenance practices; harmful chemicals.

### Harm:

Structure life will be shortened; premature failure.

### Cause:

No weep holes; no drainage facility; plugged drains.

### Harm:

Wet foundation has lower supporting capacity; uplift pressure due to accumulated seepage water may cause damage to spillway chute; accumulation of water may also increase total pressure on spillway walls and cause damage.

## ACTION REQUIRED

### Action:

Design a stable slope for channel bottom and banks. Riprap material should be well graded (the material should contain small, medium, and large particles). Subgrade should be properly prepared before placement of riprap. Install filter fabric if necessary. Control flow velocity in the spillway by proper design. Riprap should be placed according to specification. Services of an engineer are recommended.

ENGINEER REQUIRED

### Action:

Avoid using shale or sandstone for riprap. Add air-entraining agent when mixing concrete. Use only clean good quality aggregates in the concrete. Steel bars should have at least 1 inch of concrete cover. Concrete should be kept wet and protected from freezing during curing. Timber should be treated before use.

### Action:

Install weep holes on spillway walls. Inner end of hole should be surrounded and packed with graded filtering material. Install drain system under spillway near downstream end. Clean out existing weep holes. Backflush and rehabilitate drain system under the supervision of an engineer.

ENGINEER REQUIRED

**CONDITION FOUND**

10.5-10

**Concrete erosion, abrasion, and fracturing**



**PHOTO 10.5-4 — FAILED SPILLWAY**  
Fracturing of spillway chute slab

**CAUSES & HARM DONE**

**Cause:**

Flow velocity too high (usually occurs at lower end of chute in relatively high dams); rolling of gravel and rocks down the chute; cavity behind or below concrete slab.

**Harm:**

Pock marks and spalling of concrete surface may progressively become worse; small hole may cause undermining of foundation, leading to failure of structure.

**ACTION REQUIRED**

**Action:**

Remove rocks and gravels from spillway chute before flood season. Raise water level in stilling basin. Use good quality concrete. Make sure concrete surface is smooth.

**ENGINEER REQUIRED**

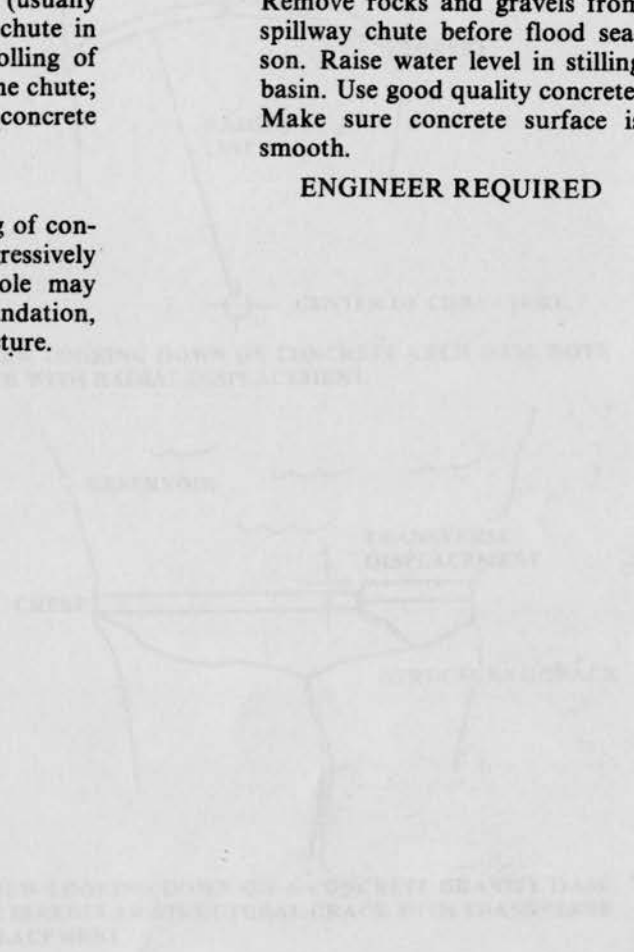

Figure 10.5-10 illustrates the failure of a spillway chute. The diagram shows the chute structure and the flow path. The failure is caused by the combination of transverse and vertical displacements, which leads to the formation of structural cracks. The diagram also shows the location of the center of curve and the direction of the flow. The failure of the structure is indicated by the dashed lines and the label 'FAILURE OF STRUCTURE'.

10.5-11 Foundation Cracks Between Weirs  
An explanation of Chapter 3 Section 3.10.1.1. The failure of the structure is caused by the combination of transverse and vertical displacements. The diagram shows the location of the center of curve and the direction of the flow. The failure of the structure is indicated by the dashed lines and the label 'FAILURE OF STRUCTURE'.

**STRUCTURAL PARTICULAR CONCERN**  
Several of these more serious problems are discussed below. It is emphasized that, should these problems be discovered, prompt attention by the consulting engineer is essential.

**Structural Cracks**

These are caused by over-stressing of portions of the dam and result because of inadequate design, poor construction techniques, or faulty materials. Structural cracks are often irregular in extending over part or all length of the major axis of the dam and may exhibit abrupt changes in direction. These cracks may have noticeable radial, transverse, or vertical displacements (see Figure 10.5-11).



Figure 10.5-11 illustrates the failure of a spillway chute. The diagram shows the chute structure and the flow path. The failure is caused by the combination of transverse and vertical displacements, which leads to the formation of structural cracks. The diagram also shows the location of the center of curve and the direction of the flow. The failure of the structure is indicated by the dashed lines and the label 'FAILURE OF STRUCTURE'.

11.1 INTRODUCTION

Now our attention will be concentrated on concrete dams in order to allow the owner to identify readily conditions that threaten the safety and long life of his structure. Although some of these items can be corrected by normal maintenance, more serious conditions will require inspection by the State Engineer's Office and may require further investigation by an experienced consulting engineer. The items requiring the attention of an engineer will be noted below as "ENGINEER REQUIRED."

From a safety standpoint, the principal advantage of concrete dams is their near immunity to failure by erosion during overtopping. Embankment slides and piping failures, typical of earth dams, are also avoided. Refer to Chapter 3, Section 6, for discussion of the basic principles which describe the behavior of concrete dams.

Although concrete dams comprise less than 1% of the total number of dams within the state, they are, on average, of greater height and storage capacity than earth structures. This makes them potentially more hazardous to life and property. It is important that dam owners be aware of the principal modes of failure and that they be able to discern between conditions which threaten the safety of the dam and those which merely indicate a need for maintenance.

11.2 ITEMS OF PARTICULAR CONCERN

Concrete dams fail for reasons different than earth dams. Several of these more serious problems are discussed below. It is emphasized that, should these conditions be discovered during inspection, the owner should obtain engineering assistance immediately.

11.2-1 Structural Cracks

These are caused by overstressing of portions of the dam and result because of inadequate design, poor construction technique, or faulty materials. Structural cracks are often irregular, meaning they run at an angle to the major axes of the dam and may exhibit abrupt changes in direction. These cracks also have noticeable radial, transverse, or vertical displacement. (See Figure 11.1.)

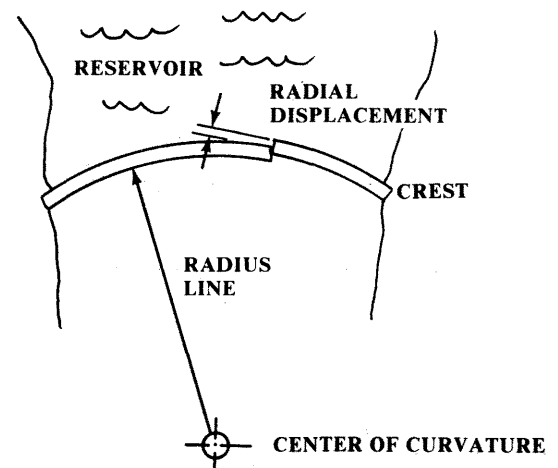

(B) VIEW LOOKING DOWN ON CONCRETE ARCH DAM. NOTE CRACK WITH RADIAL DISPLACEMENT.

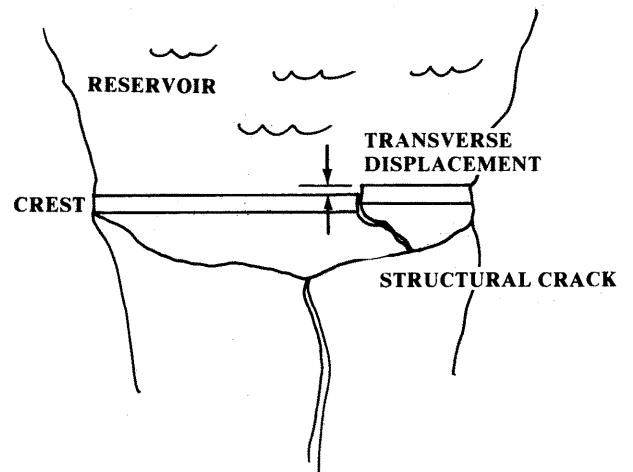

(C) VIEW LOOKING DOWN ON A CONCRETE GRAVITY DAM. NOTE IRREGULAR STRUCTURAL CRACK WITH TRANSVERSE DISPLACEMENT.

FIGURE 11.1

Figure 11.1 shows displacement measured at a single location. The amount of displacement often varies along the length of a structural crack. This variation occurs because a portion of the dam has moved in relation to the original alignment. In any case, the presence of structural cracks could be an indication of progressive failure of the abutment, the foundation, or the dam itself. Engineering assistance should be obtained.

11.2-2 Foundation or Abutment Weakness

As explained in Chapter 3, Section 6, concrete dams transfer substantial load to the abutments and foundation. Although the concrete of the dam may endure, the natural terrain may crack, crumble, or move in a massive slide. If this occurs, support for the dam is lost, causing it to fail. Examples of this process are shown in Figures 11.2 and 11.3.

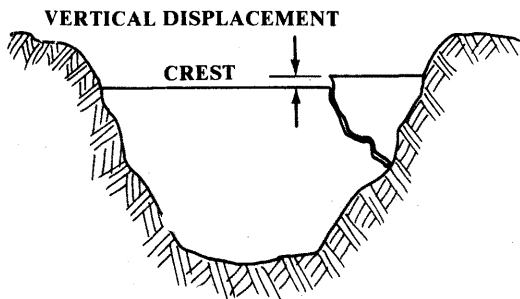

(A) VIEW LOOKING UPSTREAM AT A CONCRETE DAM. NOTE IRREGULAR STRUCTURAL CRACK WITH VERTICAL DISPLACEMENT.



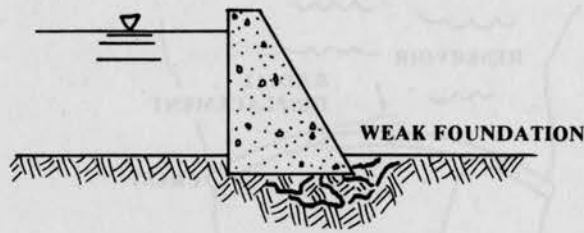

(a) Concrete gravity dam built on a weak foundation.

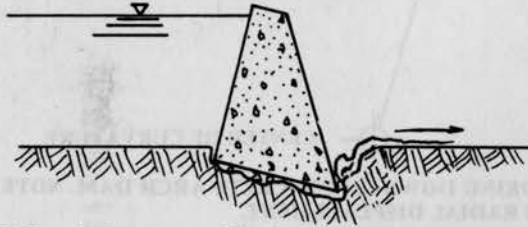

(b) Foundation starts to fail, allowing dam to be moved by the force of the water.

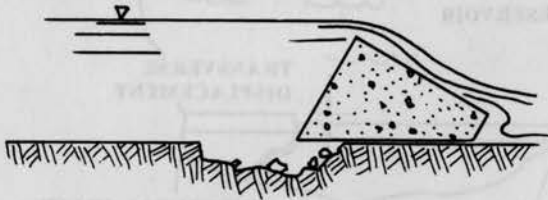

(c) Dam collapses and water is suddenly released.

**FIGURE 11.2**  
OVERTURNING FAILURE OF A CONCRETE GRAVITY DAM,  
CAUSED BY A WEAK FOUNDATION. THE SHAPE OF THE DAM  
DID NOT CHANGE. It failed because it lost support of the natural terrain.  
(Drawings are section view.)

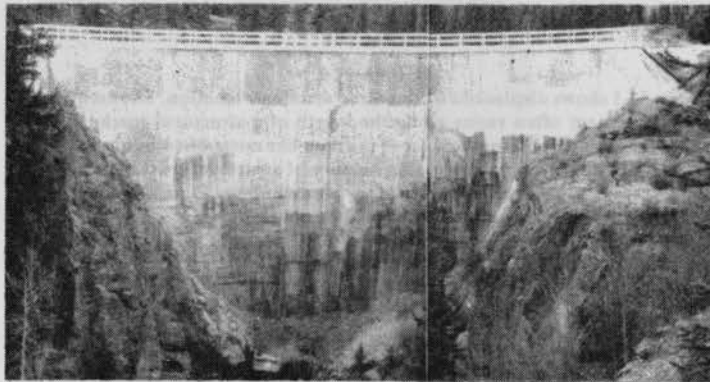

**PHOTO 11.2-1**  
ALKALI-AGGREGATE REACTION. Note typical cracking pattern of  
exposed concrete.

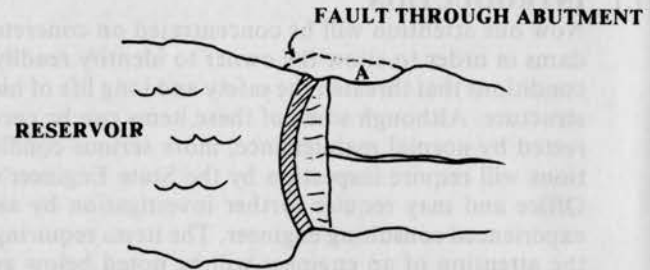

(A) CONCRETE ARCH DAM WITH A FAULT PLANE CUTTING THROUGH ONE ABUTMENT. Block "A" is unstable.

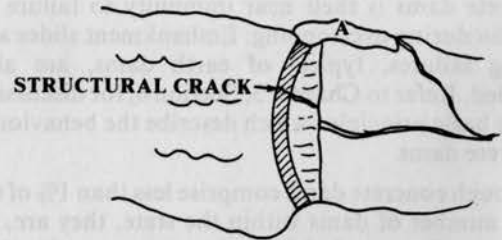

(B) BLOCK "A" MOVES DOWNSTREAM REDUCING SUPPORT FOR THE DAM. A structural crack develops, and seepage begins at weak abutment and through dam.

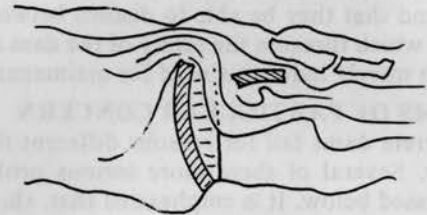

**FIGURE 11.3**  
ABUTMENT FAILURE OF A CONCRETE ARCH DAM. (Drawings  
are in plan view.)

Impending failure of the foundation or abutments is difficult to detect because initial movements are often very small. This problem will be further discussed in Section 11.3.

### 11.2-3 Deterioration Due to Alkali-Aggregate Reaction

Severe deterioration can result from a chemical reaction between alkali present in cements and certain forms of silica present in some aggregates. This chemical reaction produces byproducts in the form of silica gels which cause expansion and loss of strength within the concrete.

Alkali reaction is characterized by certain observable conditions, such as: "Cracking, usually of random pattern on a fairly large scale, and by excessive internal and overall expansion. Additional indications are a gelatinous exudation and whitish amorphous deposit on the surface, and lifeless, chalky appearance of the freshly fractured concrete."<sup>1</sup> An example of alkali-aggregate reaction is shown in Photo 11.2-1.

<sup>1</sup>Concrete Manual, U.S. Bureau of Reclamation, p. 8.

The reaction takes place in the presence of water. Surfaces exposed to the elements or dampened as a result of through dam seepage will demonstrate the most rapid deterioration. Once suspected, the condition can be confirmed by a series of tests performed on cores drilled from the dam.

Although the process of deterioration is gradual, alkali-aggregate reaction cannot be economically corrected by any means now known. Continued deterioration often requires total replacement of the structure.

### 11.3 SPECIAL INSPECTION TECHNIQUES AND REQUIREMENTS

Basic inspection of a concrete dam is similar to that of earth dams, as explained in Chapter 4. However, the following additional items should be considered:

#### Access and Safety:

The faces of concrete dams are often near vertical, and the site is commonly a steep-walled rock canyon. Access to the downstream face, toe area, and abutments may be difficult and require special safety equipment such as safety ropes, or a boatswain's chair. Close inspection of the upstream face may also require a boatswain's chair or a boat. Without this equipment, inspection of all surfaces of the dam and abutments may not be possible.

#### Monitoring:

Serious threats to concrete dams often involve cracks in the dam, abutments, or foundation. (Section 11.2.) Cracks may develop slowly at first, making it difficult to determine if they are widening or otherwise changing over time. If a suspected structural crack is discovered, it should be monitored for changes in width, length, and offset. Refer to Chapter 12, Section 12.5-4, for specific monitoring techniques. Reading of an established monitoring network should be performed on a regular basis.

#### The Outlet System:

Although outlet system deterioration is not a problem of concrete dams per se, the frequency of such damage is higher due to greater average hydraulic head. Outlet system inspection should be emphasized during inspection of tall concrete dams. Refer to Chapter 9, Section 9.5.

### 11.4 OTHER CONDITIONS TO LOOK FOR

The following conditions are common ailments for concrete dams and indicate maintenance may be required:

#### 11.4-1 Cracks at Construction Joints:

Construction joints are provided to accommodate volumetric changes which occur in the structure after concrete placement, and are referred to as "designed" cracks. These joints are so constructed that no bond or reinforcing, except non-bonded waterstops and dowels, extend across the joint. (See Section 11.2.a.) Examples of cracking at construction joints are shown in Photographs 11.4-1 and 11.4-2.

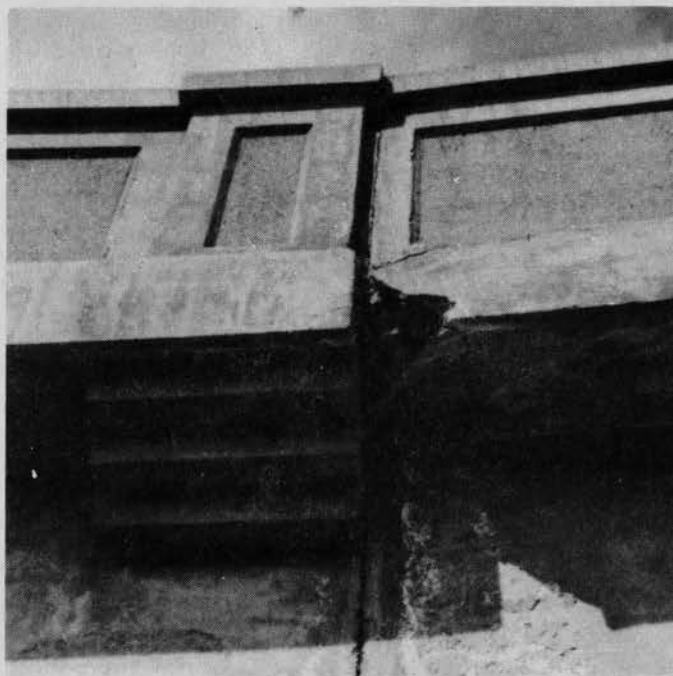

PHOTO 11.4-1  
CRACK AT VERTICAL CONSTRUCTION JOINT. Note evidence of minor leakage and spalling adjacent to joint.



PHOTO 11.4-2  
CRACKS AT HORIZONTAL CONSTRUCTION JOINT. Note evidence of minor leakage.

#### 11.4-2 Shrinkage Cracks:

These cracks often occur when, during original construction, irregularities or pockets in the abutment contact are filled with concrete and not allowed to cure fully prior to placement of adjacent portions of the dam. Subsequent shrinkage of the concrete may lead to irregular cracking at or near the abutment.

Shrinkage cracks are also caused by temperature variation. During winter months the

upper portion of the dam may become significantly colder than those portions which are in direct contact with the reservoir water. This results in cracks which extend from the crest for some distance down each face of the dam. These cracks will probably be at construction joints, if these are provided.

Shrinkage cracks can be a sign that certain portions of the dam are not carrying load.<sup>1</sup> The total compressive load must then be carried by a smaller percentage of the structure. It may be necessary to restore load-carrying capability by grouting affected areas. This work requires the assistance of an engineer.

#### 11.4-3 Deterioration Due to Spalling:

Almost every concrete dam in Colorado experiences continued minor deterioration due to the severe nature of the climate.

Spalling is the process by which concrete chips and breaks away, as a result of freeze-thaw action. Since it usually affects only the surface of the structure, it is not ordinarily considered dangerous. However, if allowed to continue, spalling will cause structural damage, particularly if the dam is of thin cross section. Also, repair is necessary when reinforcing becomes exposed to the elements.

The method of repair of spalled areas depends upon the depth of the deterioration. Repair should be considered temporary unless seepage through the dam can be halted. (Refer to Chapter 13, Section 4.)

In severe situations, engineering assistance is required to determine the best method of repair. Photos 11.4-3 and 11.4-4 are examples of damage due to severe spalling.



PHOTO 11.4-3 — STRUCTURAL DAMAGE. Spalling has exposed reinforcing.

<sup>1</sup>Design of Gravity Dams, United States Bureau of Reclamation, pp. 109-111.

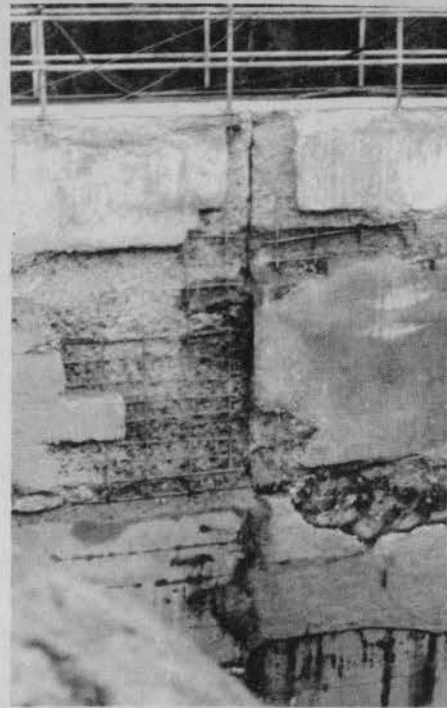

PHOTO 11.4-4  
SEVERE SPALLING HAS EXPOSED REINFORCEMENT ON THE UPSTREAM FACE OF THIS DAM.

#### 11.4-4 Minor Leakage:

Leakage through concrete dams, although unsightly, is not usually dangerous, unless accompanied by structural cracking. The worst effect may be to promote minor deterioration due to the elements through freeze-thaw action. Increases in seepage could indicate that, through chemical action, materials are being leached from the dam and carried away by the flowing water. Decreases in seepage may also occur as mineral deposits are formed in the seepage channel. In neither case is the condition inherently dangerous, and detailed study is required before it can be determined that repair is necessary for other than cosmetic reasons.

Photo 11.4-2 shows an example of typical minor seepage at a construction joint. Refer to Chapter 5 for a general discussion of seepage.

### 11.5 SUMMARY

Concrete dams pose a special problem for the inspector because of the difficulty in gaining close access to the nearly vertical surfaces. Regular inspection with a pair of powerful binoculars can initially identify areas where change from surrounding areas is occurring. When these changes are noted a detailed close up inspection should be arranged for. Any questionable condition requires immediate evaluation by an experienced engineer. Since the failure of concrete dams can occur suddenly, even a hint of a problem must be carefully evaluated by an experienced engineer.

**12.1 INTRODUCTION**

The previous chapters have dealt with the visual inspection of a dam. Although visual inspection is in fact a simple and very useful form of monitoring, this chapter deals with the more accurate physical measurement of changes which occur in dams. The monitoring of concrete dams is not specifically addressed in this chapter, but many of the principles of monitoring earth dams can be applied to concrete dams. The owner of a dam frequently hears the term instrumentation. Instrumentation refers to the method and equipment used to make physical measurements of dams. However, instrumentation is not a substitute for inspection; it is a supplement to the visual observations made during an inspection.

**12.2 FACTORS THAT CAUSE CHANGE IN CONDITION**

An earth dam will normally undergo several predictable changes throughout the life of the structure. The changes which occur and the factors causing the changes have been identified through the use of instrumentation. Furthermore, instrumentation has made it possible to distinguish between normal and abnormal changes. Knowledge of the changes which occur has enabled the engineer to design and build dams higher and higher with more and more confidence. The changes which occur are: 1) vertical displacement (settlement); 2) horizontal displacement (change in alignment); and 3) internal wetting of the embankment.

Knowing that changes occur is one thing, but more important is understanding the cause. The first changes the dam experiences occur during construction. As the height of the dam is increased, the material in the lower portion of the dam is compressed due to the weight of the material on top. The foundation may also compress (settle) due to the weight of the embankment. The changes which occur during construction are not limited to settlement. Instrumentation of earth dams under construction has shown that horizontal displacement (spreading) occurs as well. First filling of the reservoir will create a new imbalance of forces causing more horizontal displacement and additional settlement occurs as the wetting of the embankment progresses. Other factors which cause continual changes are variations in: 1) the depth of stored water (gage height); 2) the length of time maximum storage depth is present; and 3) the speed with which the reservoir is drawn down.

**12.3 CAREFUL MONITORING CAN PREVENT COSTLY PROBLEMS (i.e., SLOPPY MEASURING TECHNIQUES OR PRACTICES AND POORLY MAINTAINED EQUIPMENT CAN HIDE A PROBLEM OR CREATE A FALSE ALARM)**

The solution is obvious. The owner must have a consistent and systematic approach to monitoring of the dam. Also, by having concise records of the measurements, the owner can quickly determine if a problem is developing. The owner should fully understand the purpose of each instrument in order to understand the use of recorded measurements.

**12.4 MONITORING LEAKAGE**

**ALL DAMS WILL LEAK to varying degrees, but EVERY LEAK SHOULD BE MONITORED.**

The potential for a dam to leak will vary according to the design of the embankment, the ability of the cutoff to prevent leakage under the dam, and the tightness of the natural abutments.

Leakage should first appear at the toe drain if the dam was constructed with a drain system. If the dam does not have a drain system, leakage may appear on the downstream face.

**12.4-1 WET AREAS**

If the area is damp, the perimeter of the wet area should be staked out and the length and width of the area should be recorded. Also the degree of wetness, such as boggy, surface moist but firm underfoot, etc., should be described. An example of staking wet areas is shown in Figure 12.4-1.

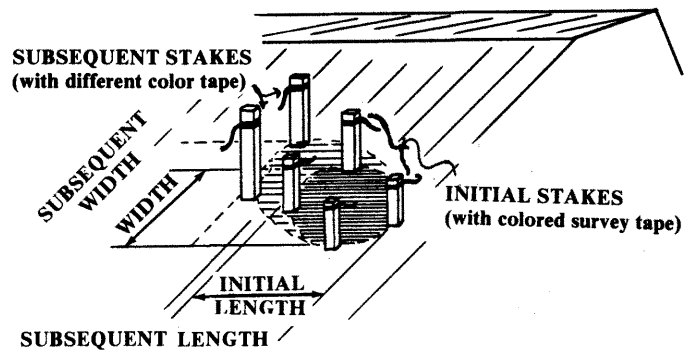
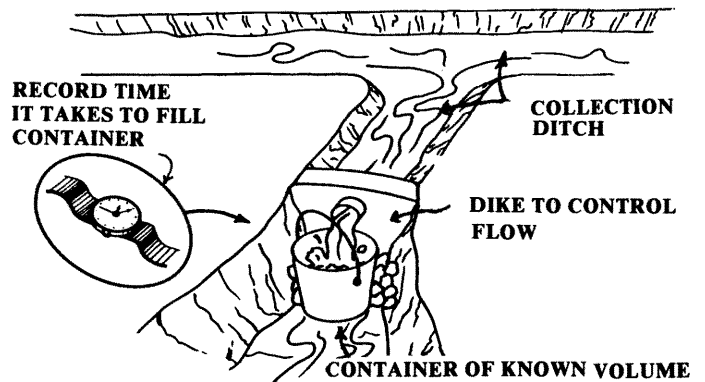

**FIGURE 12.4-1 — STAKING WET AREAS**

When the leak produces a measurable flow of water, the quantity should be monitored. First, confine the flow through drainage channels away from the embankment. Then measure the quantity flowing by creating a drop in the drainage channel and installing a pipe, a weir, or a flume.

**12.4-2 PIPE FOR TIMED BUCKET MEASUREMENT WITH STOP WATCH**

The most accurate and direct measurement can be obtained by catching the flow from a pipe in a container of known volume and timing how long it takes to fill the container as shown in Figure 12.4-2. The flow rate should be recorded in gallons per minute.



**FIGURE 12.4-2 — BUCKET AND STOPWATCH METHOD**

12.4-3 WEIR

A weir, on the other hand, can save time, but the measurement is not as direct as the bucket and stop watch. The rate of flow at a weir is related to the height of water flowing over the crest of the weir. The most commonly used, V-notch and rectangular weirs, are shown in Figures 12.4-3 a and b.

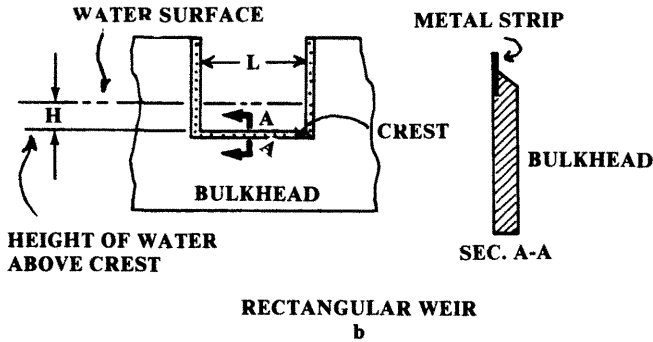
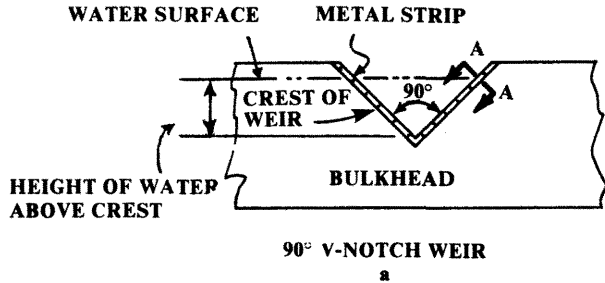

FIGURE 12.4-3 — STANDARD WEIRS

The V-notch weir is the most accurate for flows less than 450 gal/min (1 ft<sup>3</sup>/sec.). If the owner has to make a choice the V-notch weir is preferred over the rectangular weir. For comparison tables of values for the two weirs are shown in Figures 12.4-4 and 5. A typical installation of a V-notch weir is shown in Figure 12.4-4. For flows greater than 450 gal/min., larger V-notch weirs can be used or a flume can be installed.

(Tabular values may be used only with weirs of the dimensions given in the sketch below)

HEAD, H IN FEET	APPROXIMATE DISCHARGE IN GAL/MIN	HEAD, H IN FEET	APPROXIMATE DISCHARGE IN GAL/MIN
0.10	4	0.42	129
0.12	6	0.44	145
0.14	8	0.46	162
0.16	12	0.48	180
0.18	16	0.50	200
0.20	21	0.52	220
0.22	26	0.54	241
0.24	32	0.56	264
0.26	39	0.58	288
0.28	47	0.60	314
0.30	56	0.62	340
0.32	66	0.64	368
0.34	77	0.66	397
0.36	88	0.68	428
0.38	101	0.70	460
0.40	115	0.72	493

$$Q(\text{gpm}) = 2.48H^{2.48}(448.83)$$

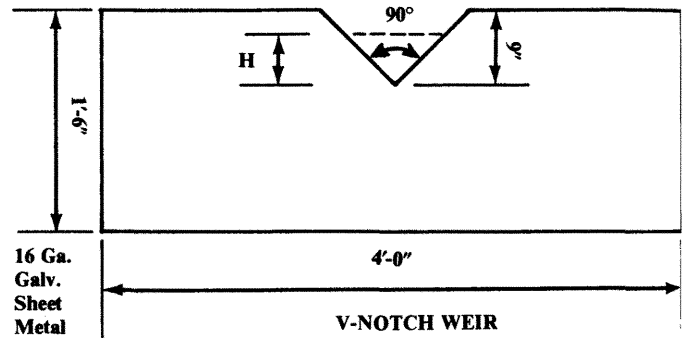

FIGURE 12.4-4  
DISCHARGE OF 90° V-NOTCH WEIRS

(Tabular values may be used only with weirs of the dimensions given in the sketch below)

HEAD, H IN FEET	APPROXIMATE DISCHARGE IN GAL/MIN	HEAD, H IN FEET	APPROXIMATE DISCHARGE IN GAL/MIN
0.02	4	0.28	209
0.04	12	0.30	231
0.06	22	0.32	253
0.08	33	0.34	276
0.10	46	0.36	300
0.12	61	0.38	324
0.14	76	0.40	348
0.16	93	0.42	373
0.18	110	0.44	398
0.20	128	0.46	423
0.22	147	0.48	449
0.24	167	0.50	476
0.26	188		

$$Q(\text{gpm}) = 3.33(L-0.2H)H^3/2(448.83)$$

FIGURE 12.4-5  
DISCHARGE OF STANDARD 1-FOOT CONTRACTED  
RECTANGULAR WEIR

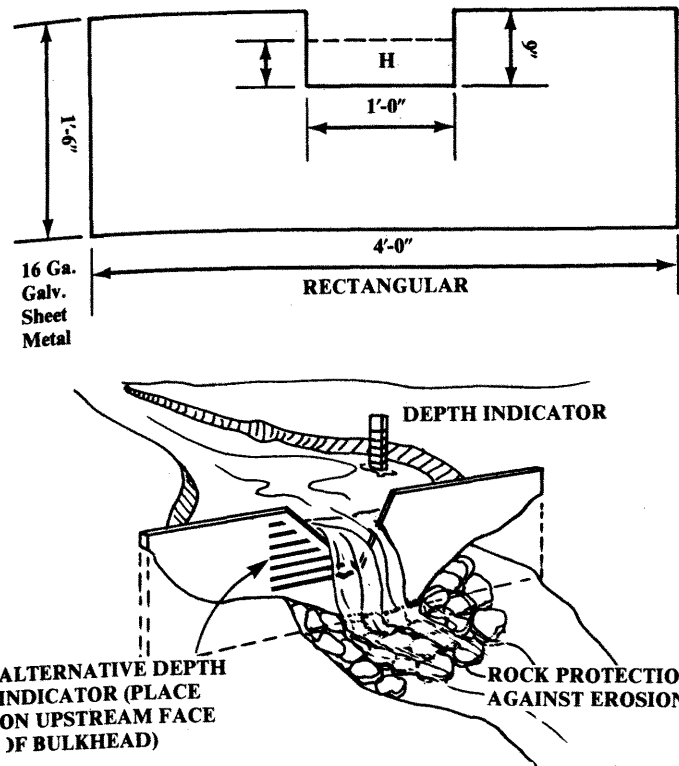

FIGURE 12.4-6 — TYPICAL V-NOTCH WEIR INSTALLATION

12.4-4 FLUMES

For larger flows, the Parshall flume is preferred to larger V-notch weirs because the flume will not restrict the flow as much as the weir.

Parshall flumes like that shown in Figure 12.4-7 can be purchased through a manufacturer and is shown here only as a guide to help the owner understand the methods used to measure leakage quantities.

FIGURE 12.4-7 PARSHALL FLUME

PARSHALL FLUME

(Installation and flow measurement according to manufacturer's instructions)

Rated Capacity		Parshall flume			Gage	Intake Width (in.)	Overall Length (ft.-in.)
cfs.	gpm.	Throat Width (in.)	Depth (in.)	Shipping Weight (lbs.)			
.082	32	1	6	13	16	6 <sup>19</sup> / <sub>32</sub>	2' - 1"
.469	210	2	10	25	16	8 <sup>13</sup> / <sub>32</sub>	2' - 6 <sup>1</sup> / <sub>2</sub> "
.64	287	3	12	55	12	10 <sup>3</sup> / <sub>16</sub>	3' - 0"
1.134	509	3	18	41	16	10 <sup>3</sup> / <sub>16</sub>	3' - 0"

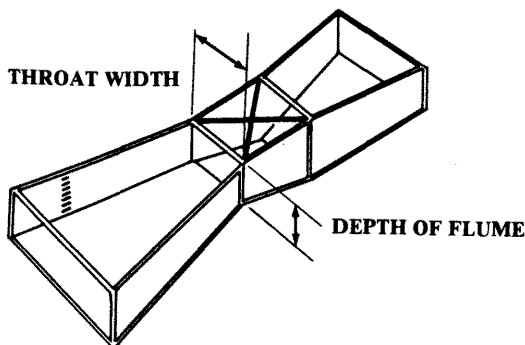

12.4-5 TURBIDITY AND SEDIMENT

Just as important as accurate measurement of leakage quantities is observation of changes in the turbidity and amount of sediment in the water. Turbidity is a measure of the amount of soil particles suspended in the water. A visual description would be the color, e.g., clear, cloudy, etc. The sediment will usually be larger particles which settle out in a jar sample of the water. An increase in the turbidity or sediment may indicate that the water is carrying soil with it as it travels through the dam, a very dangerous condition. Each time the quantity is measured, an evaluation of the turbidity and sediment should be made to observe any change.

The easiest method of comparing observations is to collect a sample of the water in a quart jar marked with the date collected and retain the sample. Another jar should be used for the next sample. A different jar should be used until five or six samples have been collected. Then the jars can be reused, starting with the one containing the oldest sample. This way, each new sample can be compared with the previous samples to observe any change in the turbidity or amount of sediment in the water.

12.4-6 RECORDS

Always remember to record reservoir gage rod height along with leakage quantities. It is also helpful to have an area map describing the location and extent of the leakage similar to the map shown in Figure 12.4-8. All pertinent features of topography and sources which may be contributing to the leakage should be included on the map.

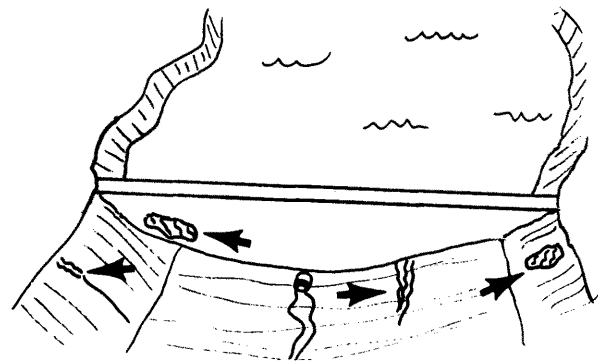

FIGURE 12.4-8 — TYPICAL MAP OF LEAKAGE AREA

In addition, leakage from toe drains and a description of any visual changes in the quality of the water (i.e., turbidity, amount of sediment) should be recorded.

A photograph of the leakage or wet area is also helpful in describing the situation.

A sample form for recording leakage measurements and wet area dimensions is shown on Figure 12.4-9. The format should be adjusted to fit each individual situation.

### 12.4-7 SEEPAGE EXITING ON THE DOWN-STREAM SLOPE

Leakage which poses the most hazardous threat to the safety of the dam is that which appears on the downstream slope. This leakage is often a result of the flow of water through the dam as described in Chapter 3. Figure 12.4-10 shows how the condition progresses with time.

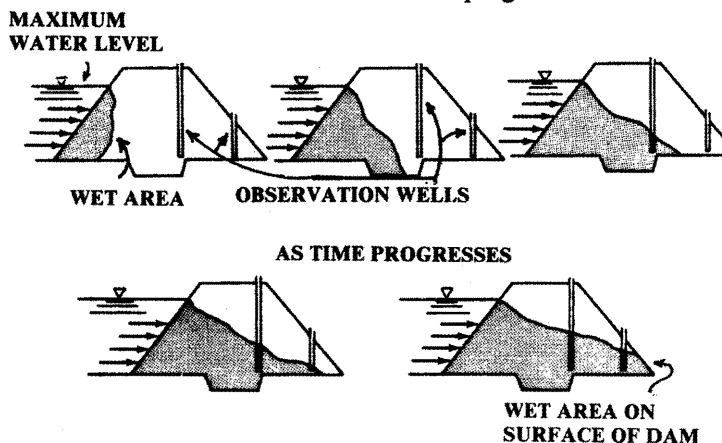

FIGURE 12.4-10 — WETTING OF EMBANKMENT

### 12.4-8 OBSERVATION WELLS

This progress of flow through the dam is easily observed by using observation wells. The use of observation wells will confirm whether or not the dam is behaving as designed to resist flow.

Figure 12.4-11 shows a typical observation well installation.

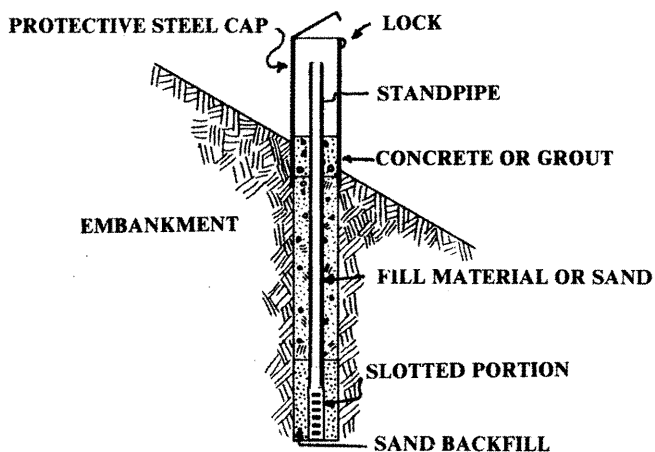

FIGURE 12.4-11 — TYPICAL OBSERVATION WELL INSTALLATION

Water in the embankment enters the standpipe through the slotted portion and rises to the same level as the water in the soil around the observation well.

Each reading of an observation well should be compared to previous readings.

A change in the reading should be evaluated as follows:

1. Draw profile of the water surface on the cross section of the dam along with the reservoir water surface (similar to that shown in Figure 12.4-13).
  - a. If the profile appears normal or what can be expected for the current height of the reservoir water surface, continue normal monitoring program. (See Chapter 3.)
  - b. If the profile appears unusual it may indicate a potentially dangerous situation (see Chapter 3). Contact State Engineer's Office and your consulting engineer.

### 12.4-9 RECORDING FORM

A sample recording sheet is shown in Figure 12.4-12. Note that space is provided for drawing cross sections. This enables the observer to evaluate the condition immediately. Graphs should also be maintained showing the entire history of observation well measurements. The format of the graphs should make them easy to update after each measurement. This will enable the observer to see the relationship between the current reading and previous readings graphically. The plot of observation well readings can be similar to Figure 12.4-13. Note that the reservoir elevation is also shown because it is the predominant variable which influences the profile of water level within the embankment.





12.5 MONITORING DISPLACEMENTS

Monitoring displacements can be helpful in understanding the normal behavior of a dam as well as being useful in determining if a potentially hazardous condition is developing. The displacements, both horizontal and vertical, are more commonly measured on the surface of the embankment. Measuring displacements of points on the surface is usually accomplished by conventional surveying methods such as leveling or alignment. Other methods are described in Section 12.6. The movements described above are not limited to just the embankment but can sometimes be traced to a point below the dam in the foundation. Internal displacement monitoring schemes can be complex and expensive. Therefore, the measurement of displacements is usually monitored on the surface, unless a problem develops.

12.5-1 ALIGNMENT AND SETTLEMENT

A simple system for monitoring displacements on the surface consists of a few permanent points across the crest of the dam. The points are usually marked with a 3-foot length of 1-inch diameter rebar set in concrete. A typical installation is shown in Figure 12.5-1.

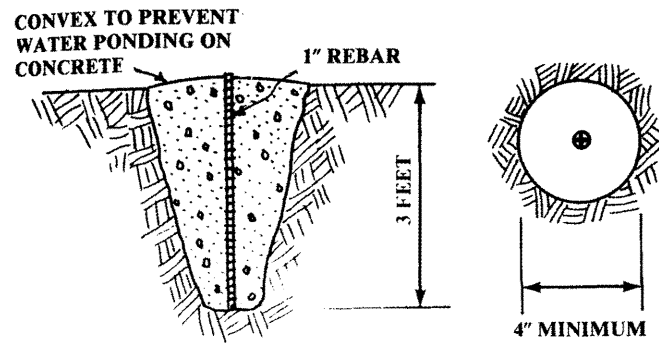

FIGURE 12.5-1 — INSTALLATION OF PERMANENT POINTS

The top of the rebar is marked with a cross or center punched hole. All points are initially set on one line-of-sight established between an instrument station on one abutment and a target station on the other abutment as shown in Figure 12.5-2.

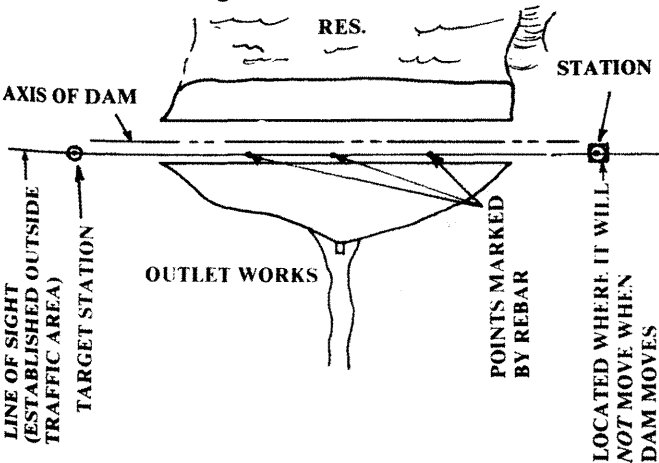

FIGURE 12.5-2 — PLAN OF ALIGNMENT SYSTEM

The alignment system measures the change in the point's position relative to the line of sight. Subsequent measurements are compared with the initial. The amount of horizontal displacement from the line-of-sight and the change in elevation from the initial is reported. The rate of settlement and horizontal displacement with time or reservoir gage height can be observed.

The single line-of-sight system can be expanded to include two or even three lines-of-sight to monitor points across the upstream and downstream face. More often the alignment monitoring system is used to establish behavior patterns of the dam especially during filling of the reservoir or during the construction of modifications to the dam.

12.5-2 CRACKS ON THE EMBANKMENT

The owner is frequently faced with special situations where the temporary and immediate monitoring of potentially dangerous conditions is needed. Sometimes this calls for a little imagination on the part of the owner and the use of common materials one may find in his own backyard.

Suppose a small crack is observed on the embankment. It would be important to know if the crack enlarges. An easy method of monitoring the crack is to drive rebar or stakes on both sides to monitor additional separation and vertical displacement on one side of the crack relative to the other side. Also, the end of the crack should be staked to determine if the crack is lengthening. The example is shown in Figure 12.5-3 a and b. This scheme can be used to monitor both longitudinal and transverse cracking.

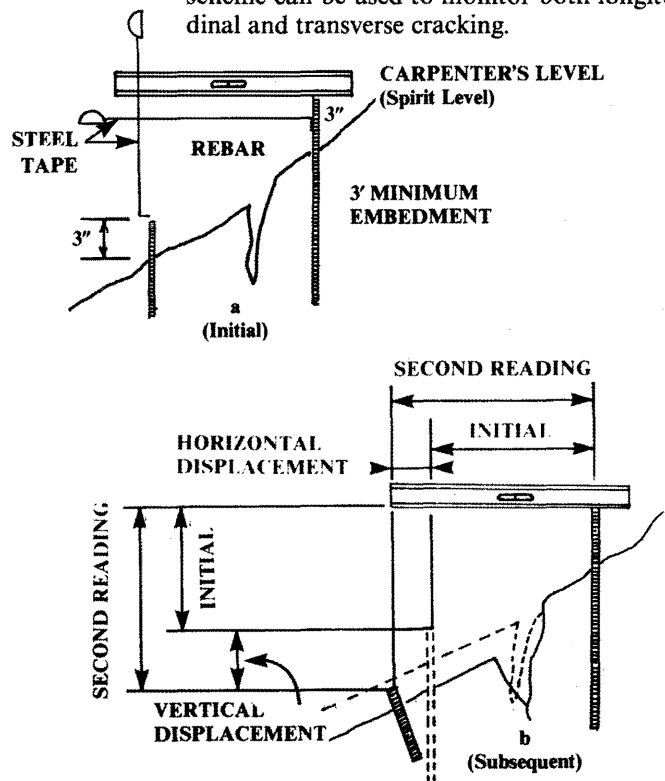
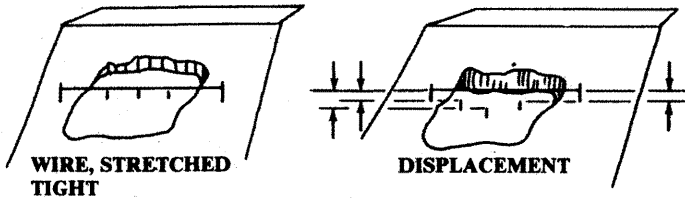

FIGURE 12.5-3 — MONITORING CRACKS ON EMBANKMENT

**12.5-3 SLIDE ON EMBANKMENT**

Another special situation which would require immediate attention is a slide. The method shown is simple yet reliable and utilizes the same principle as the alignment method. A strong wire is stretched across the slide and tied to pins outside the slide area. At intervals along the wire, pins are driven into the slide mass as shown in Figure 12.5-4. If additional movement occurs, the amount is directly determined by measuring the distance between the pins and the wire.



**FIGURE 12.5-4 — MONITORING A SLIDE**

**12.5-4 DISPLACEMENTS OF CONCRETE STRUCTURES**

The owner should also concentrate on monitoring changes in the concrete structures associated with the dam, such as the spillway and outlet works. The owner should monitor vertical, horizontal, and lateral displacements; structural cracking; and tilting of walls in spillways or the drop structure for the outlet. A few simple methods are illustrated in Figure 12.5-5.

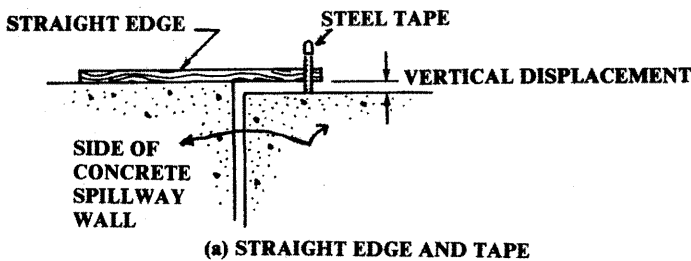

**(a) STRAIGHT EDGE AND TAPE**

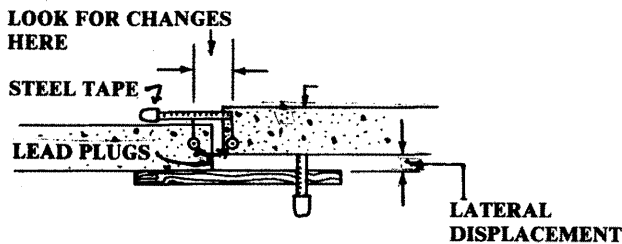

**(b) STRAIGHT EDGE AND TAPE PLUS REFERENCE POINTS**

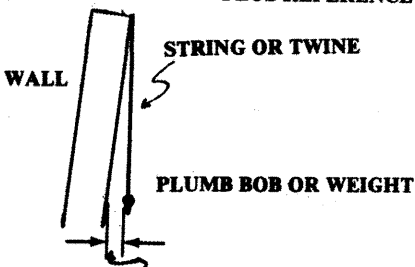

**(c) PLUMB BOB**

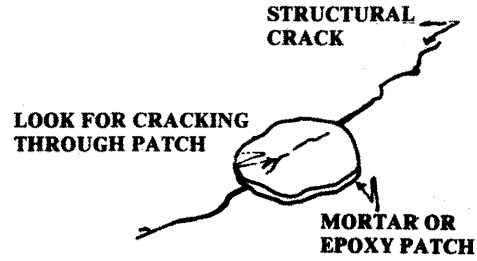

**(d) MORTAR MARKER**

**FIGURE 12.5-5 — MEASURING DISPLACEMENTS**

The information from routine measurement of displacements will tell the owner if movement is continuing and at what pace.

**12.6 SPECIALIZED INSTRUMENTATION**

The requirements for specialized instrumentation are more often specific to each individual dam site and require an evaluation by an engineer. Entire books have been written on the three types of specialized instrumentation presented in this section. Therefore, this section will provide the owner of a dam only general information to allow the owners to communicate better with the engineer.

The three types of instrumentation presented are 1) piezometers, 2) inclinometers, and 3) triangulation/trilateration. Following the section are charts the owner can use for quick reference.

**12.6-1 PIEZOMETERS**

Unlike the observation well, which directly shows the height of water in the embankment or foundation, a piezometer indicates the pressure exerted by the height of water above the tip of the piezometer. The pressure, though, can be related to the height of water in the embankment or foundation. The similarity between the piezometer and observation well would make the piezometer less desirable because of added expense. However, the piezometer can perform other functions which an observation well cannot.

The advantage of the piezometer can best be shown in a case where foundation water pressure is being measured. The case in point is where the equivalent height of a column of water for the pressure being measured by the piezometer would exceed the height of the dam.

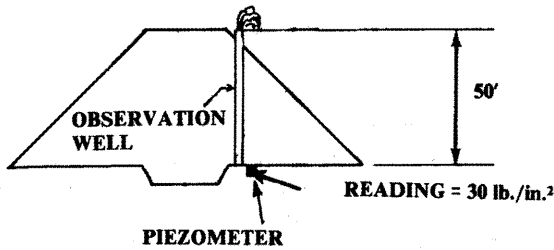

FIGURE 12.6-1 — PIEZOMETER V.S. OBSERVATION WELL

For the example above, the equivalent height of water for a piezometer reading of 30 lb/in<sup>2</sup> is 70 feet, 20 feet above the crest of the dam. Do not be misled by the example because it is not typical. However, the situation can develop and should be evaluated by an engineer. There are several types of piezometer available (i.e., open tube, hydraulic, pneumatic, electric, etc.). Selection is made based on use, cost, and availability.

12.6-2 INCLINOMETERS

Inclinometers are used to monitor internal displacements of the embankment or movements in the foundation. The purpose and advantage of making measurements of internal movements are that the movements will undoubtedly be detected before the effects appear on the surface.

The embankment and foundation deforms and causes the surface to move. Therefore, surface monitoring of displacements does not always tell the entire story of "what is happening."

The inclinometer is designed to measure horizontal movements of the embankment and/or the foundation at any depth below the surface. The system consists of a special casing with grooves on the inside at the quarter points.

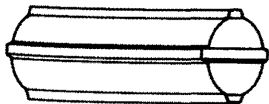

GROOVES ARE GUIDES FOR THE WHEELS ON THE PORTABLE INSTRUMENT

FIGURE 12.6-2 — INCLINOMETER CASING

The casing is installed in a drilled hole and backfilled with material selected by the engineer.

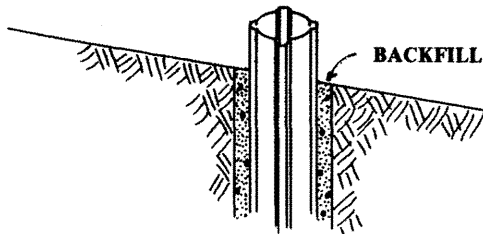

FIGURE 12.6-3 — INCLINOMETER — Detail at surface

Then an instrument is used to traverse the length of the casing and determine its profile in two perpendicular directions.

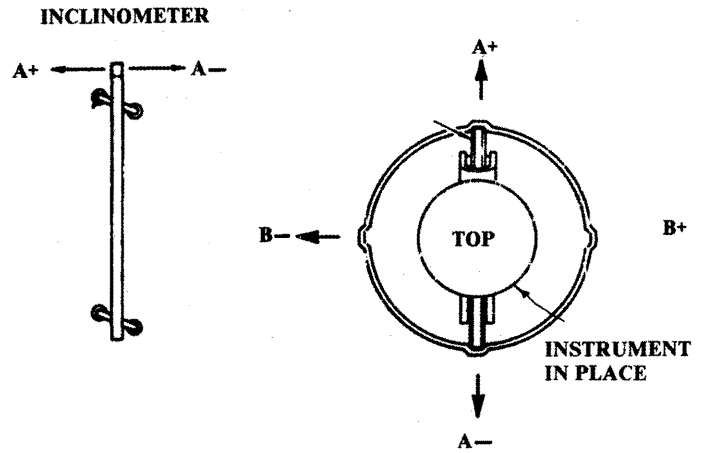

FIGURE 12.6-4 — INCLINOMETER AND CASING

All readings are compared with the initial profile to determine if changes have occurred. The results are usually presented on a graph as shown below.

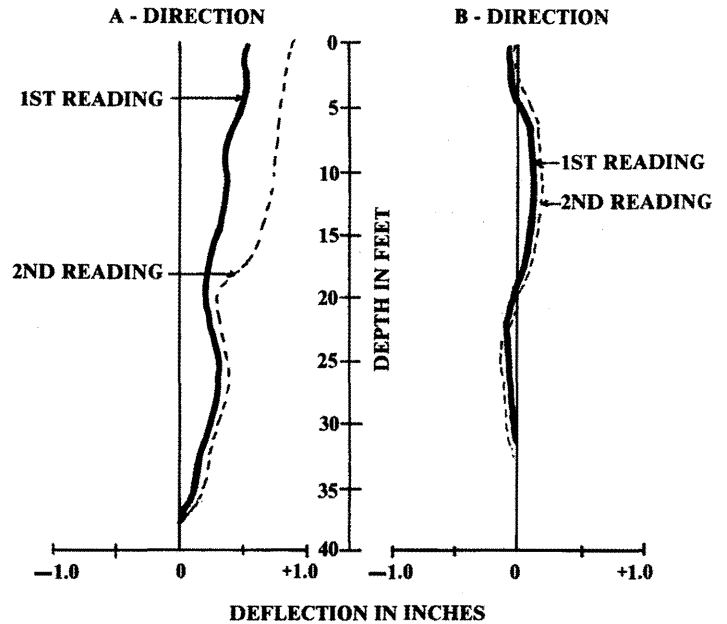

FIGURE 12.6-5 — PLOT OF INCLINOMETER READINGS

In the above graph the movement that took place between the first and second reading is less than 1/4 inch. The small displacement could not have been measured by conventional surveying methods on the surface. Inclinometers are most beneficial if installed before a surface movement is detected.

### 12.6-3 TRIANGULATION/TRILATERATION

For dams with a long crest length, the line-of-sight can be excessively long. In this case, the line of sight is frequently moved downstream of the dam and becomes a baseline. Displacements are monitored by turning angles from fixed points on the baseline to points on the dam. The system forms triangles and is known as triangulation. Instead of measuring angles, sometimes the horizontal distances between the end points of the baseline and points on the dam are monitored using electronic distance measuring (EDM). The distance measuring scheme is known as trilateration. Triangulation and trilateration are strictly for horizontal control.

It should be emphasized here that the more elaborate the scheme for monitoring surface movements, the more important it is to consult a qualified engineer or land surveyor.

### 12.7 SUMMARY

Instrumentation refers to the method and equipment used to make physical measurements of dams. However, instrumentation is not a substitute for inspection. It is a supplement to the visual observations made during an inspection.

Instrumentation of dams can provide information about the behavior of the structure under normal operating conditions. More frequently though, the owner is faced with special or unusual situations which develop. Whether the situation involves leakage or displacement, it calls for immediate attention. With a little bit of imagination and the suggested methods presented in the chapter, the owner can obtain information to assess the performance of his dam better.

## SPECIALIZED INSTRUMENTATION

### TYPE

#### PIEZOMETER

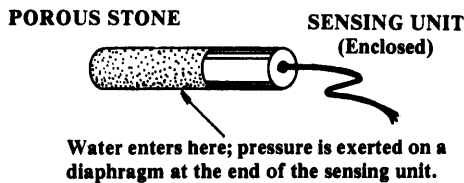

#### TO PORE PRESSURE TERMINAL

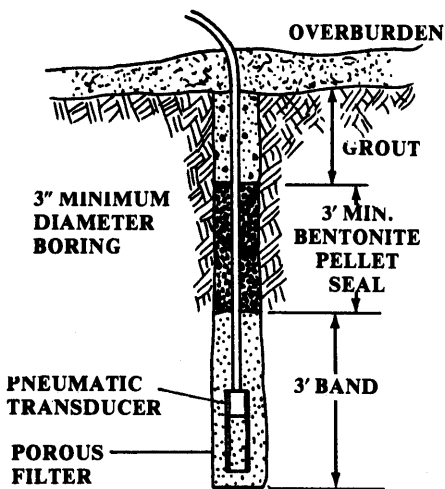

INSTALLATION DETAIL  
(TYPICAL)

### PURPOSE AND GENERAL DESCRIPTION

The piezometer measures the pressure of water entering the porous stone. In the case of an earth dam the pressure is primarily due to the infiltration of water into the embankment from the reservoir. The pressure exerted on the piezometer is a function of the height reached by the water in the embankment above the piezometer.

The advantage the piezometer has over the observation well is the ability to measure small changes in the water level above it. A piezometer also has a more rapid response to changes of water pressure in the embankment. The piezometer can also sense changes in the water pressure created by factors other than increase in the water level in the embankment.

A piezometer can be installed in the foundation under the embankment. The figure at left is a typical installation detail.

An engineer should be consulted to evaluate the need and supervise the installation of piezometers.

**SPECIALIZED INSTRUMENTATION**

**TYPE  
INCLINOMETER**

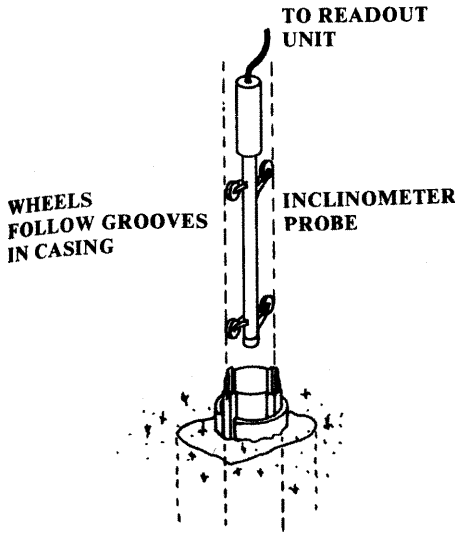

**SURFACE INSTALLATION  
DETAIL**

**PURPOSE AND GENERAL DESCRIPTION**

The inclinometer is a system used to measure the inclination of a special casing installed in the embankment portion of a dam.

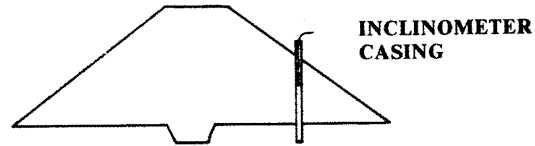

The inclinometer probe will detect small horizontal displacements of the casing. Many times the displacements are small but can be a sign of internal movement of the dam. Being able to detect small internal movements can warn against a large movement before it is observed on the surface as a crack or slide.

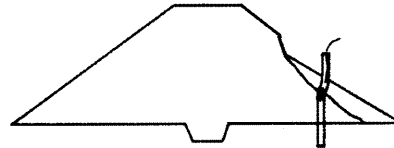

An engineer should be consulted to determine the location and supervise the installation of inclinometers.

**TYPE**

**TRIANGULATION/  
TRILATERATION**

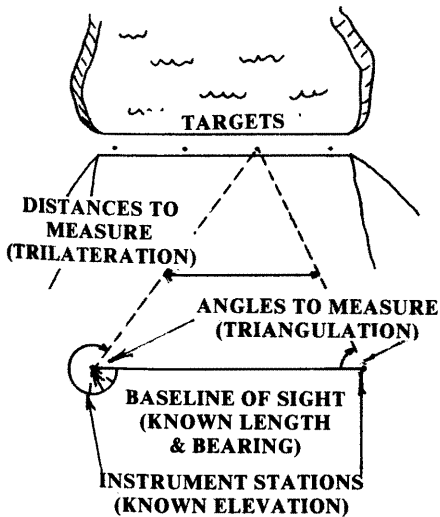

**PURPOSE AND GENERAL DESCRIPTION**

The instrument is positioned over the station. A target is placed on the other instrument station and at the point to monitor on the dam.

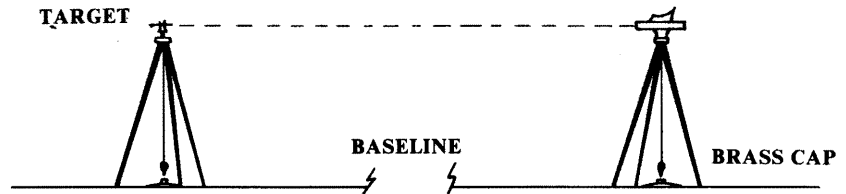

Once the sight on the baseline is established the angle between the baseline and the line to the target is measured.

After measuring angles to all targets the instrument is moved to the other station and the other angles from the baseline to the targets are measured.

Probably the most common source of error is not having the instrument exactly plumb.



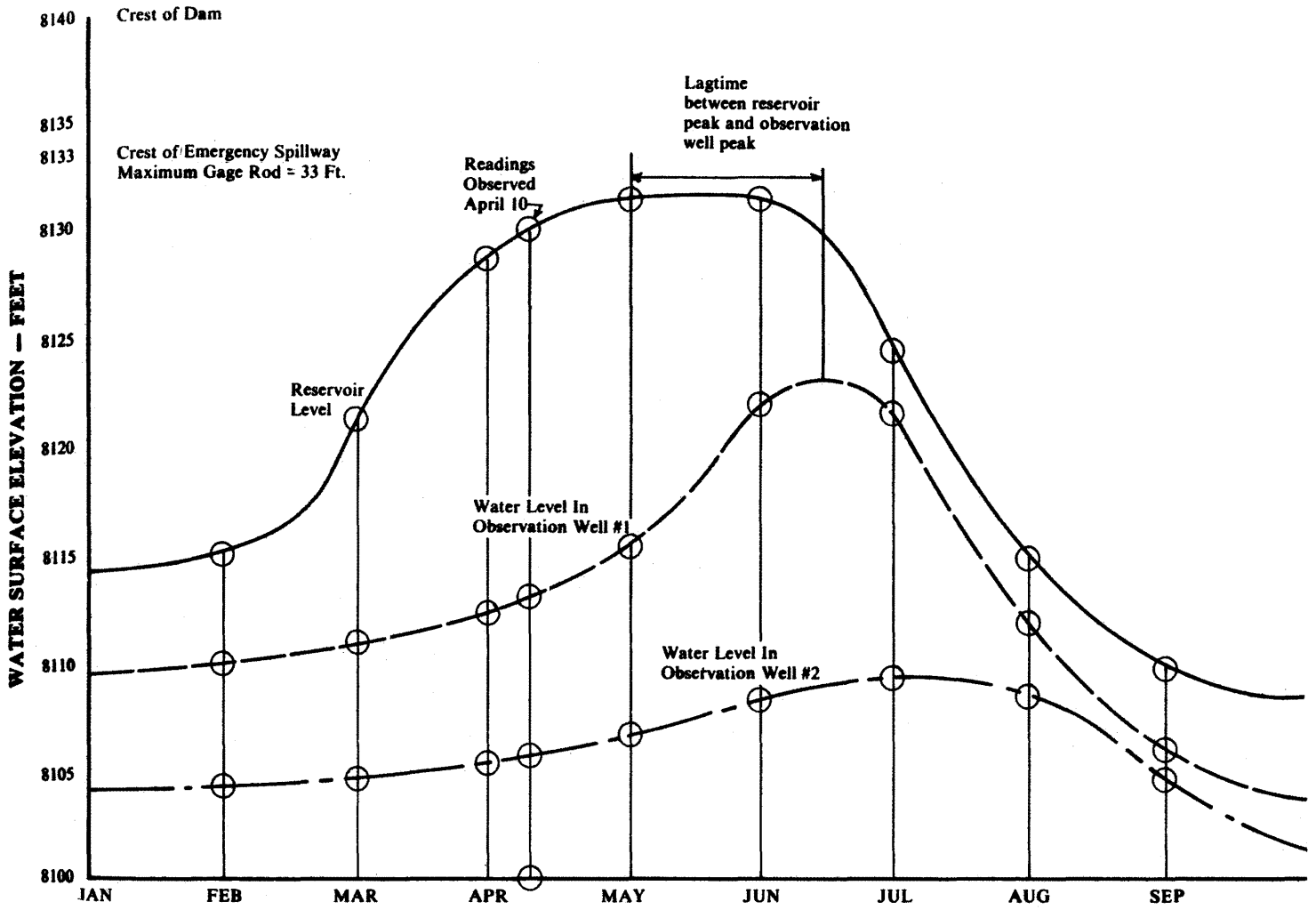

FIGURE 12.4-13 — GRAPH OF OBSERVATION WELL READINGS

**13.1 TREE, BRUSH AND WEED CONTROL**

**13.1-1 INTRODUCTION**

Periodic maintenance is required to keep any dam in safe operating condition. The first maintenance requirement is to keep all portions of the dam clear of unwanted vegetative growth. Excessive growth is harmful in the following ways:

- a. It can obscure the view of the embankment and prevent a thorough inspection for possible cracks or other evidence of problems on the dam.
- b. Large trees could be uprooted during a storm and the resulting large hole left by the root system could lead to breaching of the dam.
- c. Some root systems can decay and rot, providing a tunnel for water to pass through (called piping).
- d. Root systems can cause the uplift of concrete slabs or structures.

- e. Weeds can discourage the growth of desirable grasses.
- f. A muskrat habitat is taken away when cattails are cleared from around a dam. When trees are too far away from a water source, beavers are discouraged from building dams in the spillway or outlet.

After the removal of brush, the cuttings may need to be burned. Take precautionary measures and contact the fire department, forest service, or respective agency responsible for fires. When brush is cut down, it should be hauled off the dam to allow a clear view of the embankment.

Additional follow-up work would include:

Excavate and remove left-over root systems.

Fill in resulting holes. See earthwork section.

The following charts show various removal methods.

**CHART 13.1-2  
METHODS OF TREE, BRUSH, AND WEED CONTROL**

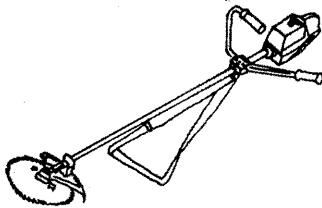
METHOD	PURPOSE	TIMING	ACTION REQUIRED
1. Repeated Cutting 	Eliminate food - producing leaves, then roots starve.	Do several times each year; control of growth takes one year.	Hand cut, machine cut, mow, if the growth is palatable; vegetation can be grazed heavily by livestock.
2. Spraying foliage with Herbicides	Increase toxic levels in the plant till the plant dies.	Spray shortly after the plant's full development of the year's leaf crop.	FOLLOW DIRECTIONS ON HERBICIDE PACKAGE.

NOTE: For further information on the use of herbicides, contact Colorado State University Extension Service Director, Ft. Collins, Colorado 303-491-6537, or your county extension agent.

**Types M CPA** — (4-chloro-2-methylphenoxyacetate acid) for weeds mostly. Non-poisonous, non-staining, non-flammable.

**2, 4-D** — (2, 4-dichlorophenoxy-acetate acid) this herbicide has proven to be effective against most broad leaf weeds and woody plants, the ester formulation is most effective. Non-poisonous, non-staining, non-flammable.



METHOD	PURPOSE	TIMING	ACTION REQUIRED
3. Digging or grubbing	Remove root growth and sprout-producing buds.	Any time.	Hand dig, use crawler-mounted dozer which may be equipped with widely spaced teeth. Dig 6 inches and uproot the root crown. Remove roots from the site. Some additional followup work may be required. Fill placement and compaction may be required.
4. Cabling	Uproot medium to small trees and stiff bushes.	Any time	Two tractors pull alternately in opposite directions until the plant's roots are torn loose. Expensive.
5. Burning	Remove above ground vegetation. Kill phloem tissue located inside the bark.	Best — late spring	Obtain permit if necessary. Assure control over burning with fire breaks and proper weather conditions. Following burning, sprouts produced by the more hearty roots will have to be eliminated.
6. Girdling	Kill the plant by girdling.	Any time. Most time-consuming, takes one to three years.	Remove a circumferential strip of bark from the trunk of the plant. This removes the phloem tissue and kills the plant by starvation of the roots. Periodic additional cutting may be necessary.  NOTE: Always remove dead trees, brush, and weeds from the dam to allow for a better visual inspection of the dam.

## 13.2 EARTHWORK

### 13.2-1 GENERAL REPAIR PROCEDURE

Deterioration of the surfaces of an earth dam may occur for a number of reasons. For example, wave action may cut scarps into the upstream slope, vehicles may cause ruts in the crest, or runoff waters may leave erosion gullies on the downstream slope. Damage of this nature must be repaired on a continuing basis. The maintenance procedures which follow are applicable to **minor** earthwork repair.

This section is not intended to be a technical guide, and the methods discussed should not be used to solve serious problems. Conditions such as embankment slides, structural cracking, and sinkholes threaten the safety of the dam **and require repair under the direction of an engineer.**

The following procedures apply to repair of conditions often found during inspection, especially:

**Vehicle ruts** on the crest of the dam.

**Gullies** on the upstream or downstream slopes, resulting from erosion by runoff waters.

**Scarps** or eroded areas on the upstream slope, caused by wave action.

**Special problems** such as drying cracks, rodent damage, and sealing reservoir basins.

### 13.2-2 SELECTION OF MATERIAL

Material selection depends upon the purpose of the earth work. In general, earth should be free of vegetation, organics, trash, or large rock. The majority of the earth should be fine-grained soils or consist of earth clods which easily break down when

worked with compaction equipment. The intent is to select a material which, when compacted, forms a firm, solid mass, free of voids.

The type of material selected depends upon the type of repair, and the purpose of that portion of the embankment. If flow-resistant portions of the fill are being repaired, select materials which are high in clay or silt content. If the repair is to be free draining (e.g., riprap bedding, etc.) the material should have a higher percentage of sands and gravels. It is best to replace or repair with soils of types similar to those originally in place.

**13.2-3 MOISTURE CONTENT**

An important soil property affecting compaction is moisture content. Soils which are too dry or too wet do not compact well. Borrow area material may be tested by roughly checking its ability to be compacted. The inspector should grab a handful of loose earth and squeeze it into a tight ball. If the sample maintains its shape without cracking and falling apart (which means it is too dry), and without depositing excess water onto his hand (which means it is too wet), the moisture content is probably near the proper level.

A soil's ability to be compacted can also be checked in a manner similar to that shown in Figure 13.2-1. All that is needed is a coffee can and a stick. Soils which are too dry fluff up and form dust when tamped, while those which are too wet bulge up around the stick.

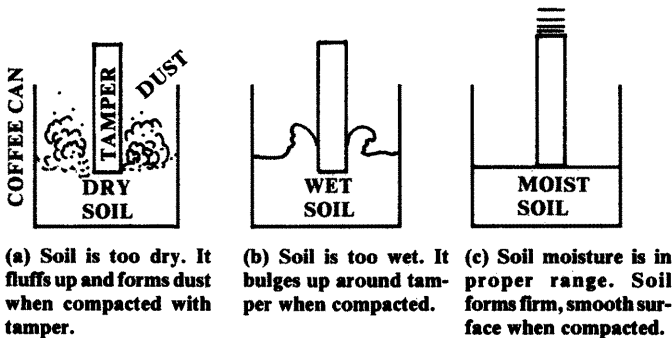

**FIGURE 13.2-1**

To see if the soil in Figure 13.2-1(c) is forming a tight matrix, remove it from the container and break it apart to confirm that each soil particle is fully surrounded by an earth mass (i.e., no voids).

**13.2-4 EARTH PLACEMENT**

Prior to placement of earth, the repair area must be prepared by removing all non-suitable material. Vegetation such as brush, roots, and tree stumps must be cleared and any large rock or trash removed. Also, non-suitable earth, such as organic or loose soils, should be removed so that the work area surface consists of exposed "clean" and firm embankment material.

Following clean-up, the affected area should be shaped and dressed so that the new fill can be compacted and will properly tie in to existing fill. If possible, slopes should be trimmed back to about a 2:1 inclination, and surfaces roughened by scarifying or plowing. This will improve bond between the new and existing fill and provide a reasonable base to compact against. (See Figure 13.2-2(b).)

Soils should be placed in loose lifts about 8 inches in maximum thickness and compacted by hand or with equipment to form a dense mass, free of large rock, streaks, lenses, or organic material. (See Figure 13.2-2(c).) Soil moisture content must be maintained in the proper range. The fill should be watered and mixed if too dry, and allowed to dry out if too wet.

During the backfilling operation, care must be exercised so the fill does not accidentally become too wet due to rainstorm runoff. Runoff waters should be directed away from the work area, and the fill brought up so that it maintains a crown which will shed water. (See Figure 13.2-2(d).)

SECTION VIEW

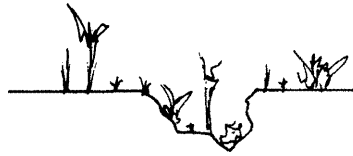
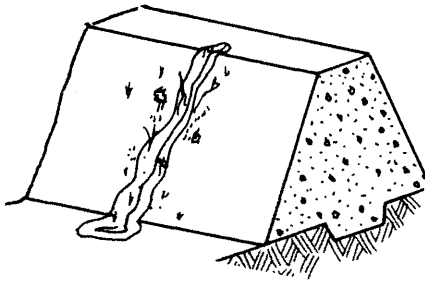

(a) ORIGINAL CONDITION.  
Gully is about 12 inches deep, and has collected trash and debris.

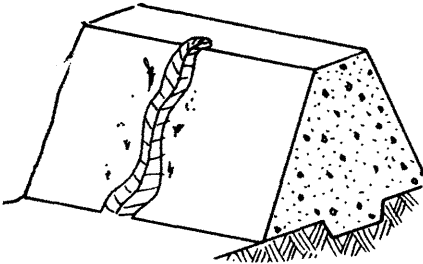

(b) AFTER CLEAN UP. Brush and debris removed and sides of the gully pulled back to a gentle slope.

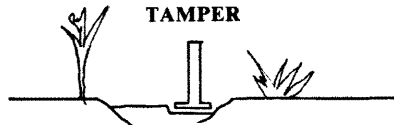
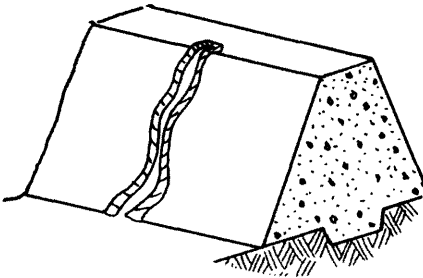

TAMPER

(c) PLACE OF FIRST LIFT.  
Soil is placed in a loose layer about 8 inches in thickness, and then thoroughly tamped until it forms a firm surface.

After compaction of first lift.

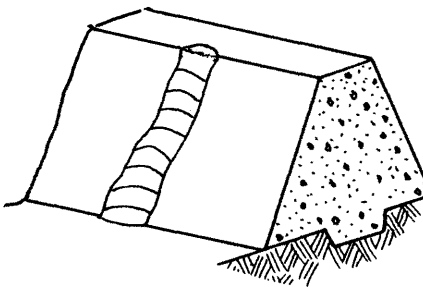

(d) PLACEMENT OF LAST LIFT  
Again, loose earth thickness is about 6 inches. Slightly overfill the gully so the final ground surface is a little above the surrounding terrain.

The final result. Slight camber shown at "a".

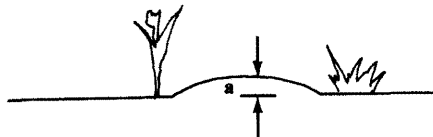

FIGURE 13.2-2

### 13.2-5 QUALITY CONTROL

The prior two sections were written so the dam owner could ensure a reasonably good job with materials and equipment on hand. If the repair job is of large size or done by others under contract, certain tests are recommended to make sure the work is of good quality (i.e., worth the money spent on it). A few of these tests are listed in Table 13.2-1. These require special equipment and should be performed by an engineer or technician familiar with soils testing. For more information, see footnote<sup>1</sup>.

**TABLE 13.2-1  
EARTHWORK QUALITY CONTROL  
TESTING**

NAME OF TEST OR PROCEDURE	DESCRIPTION AND USE
FIELD DENSITY TEST	A test to determine the in-place (field) density of soil. This test is the only way to be sure that earth has been properly placed and packed in.  The field density test is only meaningful when used in comparison to results of the proctor compaction test.
PROCTOR COMPACTION TEST	This test determines what a soil's moisture content should be for best compaction and serves as a standard of comparison for the field density test.  It is a laboratory test procedure to determine the relation between a soil's water content and its density for a specified compactive effort.
GRADATION ANALYSIS	A curve showing the particle size breakdown for a particular sample of soil. Perform this test on selected borrow material to see if it is mostly granular and free draining (sands and gravels) or fine grained and flow resistant (silts and clays).

### 13.2-6 REPAIRING RODENT DAMAGE

The type of treatment depends upon the nature of the damage which has been done to the embankment by the rodents. In any case, extermination of the rodent population is the required first step. (See Section 13.3.)

If rodent damage consists of mostly shallow holes scattered across the embankment, repair may be necessary for cosmetic reasons, to keep runoff waters from infiltrating the dam, or to discourage rodents from subsequently returning to the embankment to convenient homes. In these cases, tamping of earth into the rodent hole should be sufficient. Try to get soils as deeply as possible into the dam and compact in place with a pole or shovel handle.

Different repair measures are necessary where a dam has been damaged by extensive small rodent tunneling or by beaver or muskrat activity. In these cases, it may be necessary to excavate the damaged area down to competent fill and repair as previously described under Section 13.2-4.

Occasionally, rodent activity will result in passages which pierce the embankment and leave tunnels resulting in leakage of reservoir waters. In these cases, plugging the downstream end of the tunnel **should be avoided** as it will add to saturation of the dam. Holes which pierce the embankment are a significant hazard, as they provide a passageway which could eventually develop into a piping failure of the dam. Tunnels of rodents or ground squirrels will normally be above the phreatic surface with primary entrance on the downstream side of the dam, while those of beaver and muskrat normally occur below or at the water surface with entrance on the upstream slope.

If a rodent hole is found to extend through the dam, the best procedure is first to locate the upstream end of the passage. The area around the entrance should be excavated and then backfilled with impervious material. This procedure places a plug or patch at the passage entrance so that reservoir waters are kept from saturating the interior of the dam. (See Figure 13.2-3.) This should be considered a temporary repair. Excavation and backfilling of the entire rodent tunnel may be the only feasible method of repair.

<sup>1</sup>Earth Manual, United States Bureau of Reclamation, pp. 424, 466, 613.

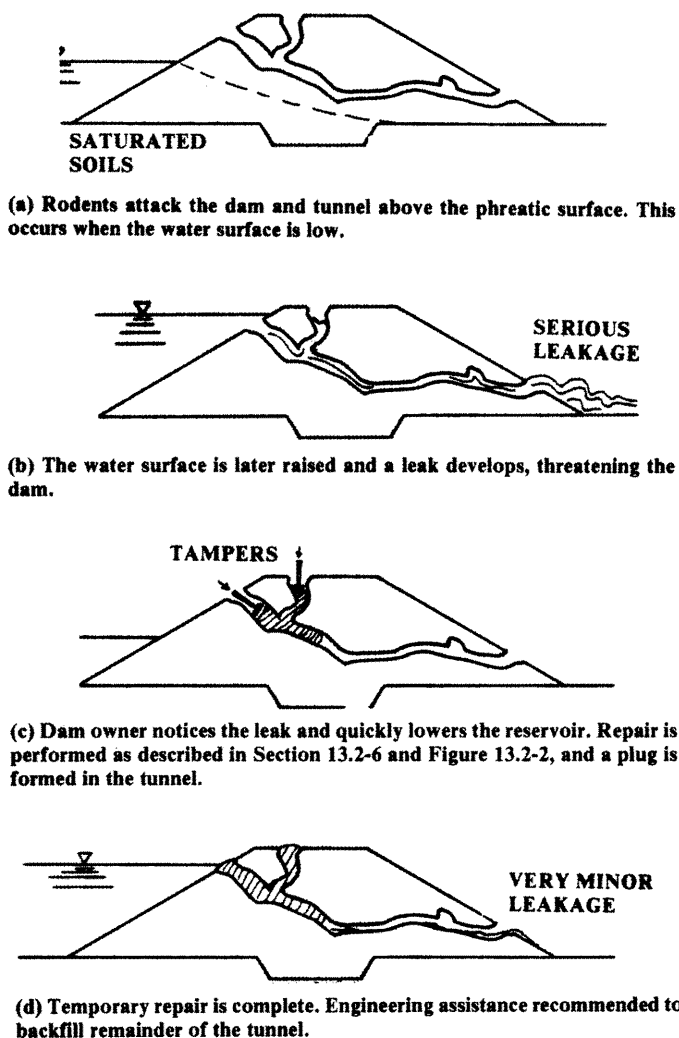

**FIGURE 13.2-3**  
**TEMPORARY REPAIR OF DAM WHEN RODENT TUNNEL**  
**PIERCES THE EMBANKMENT**

Filling of rodent holes by pressure grouting is an expensive and sometimes dangerous procedure. Pressures exerted during grouting can cause additional damage to the embankment due to hydraulic fracturing. Grouting should be performed only under the direction of an engineer.

**13.2-7 FILLING MINOR CRACKS**

Occasionally, minor cracks will form in an earth dam due to surface drying. These are called dessication, or drying, cracks and are not to be confused with structural or settlement cracking as previously discussed in this manual. Drying cracks are usually parallel to the main axis of the dam, typically near the up or downstream shoulders of the crest. These cracks often run intermittently along the length of the dam and have depths of up to 4 feet. The key to distinguishing drying cracks from other more serious structural

cracking is that the former are usually no wider than a few inches and display no "vertical offset." (See Figure 13.2-4 below and Photograph 7.5-8 in Chapter 7.)

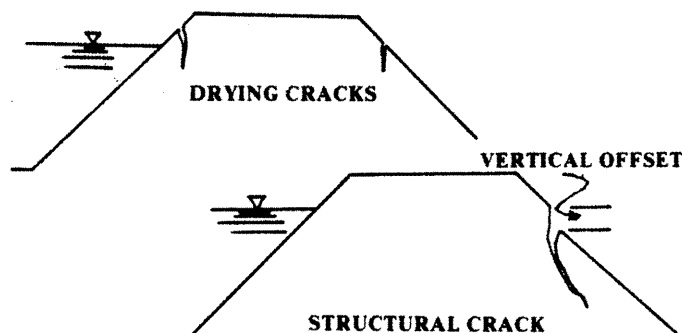

**FIGURE 13.2-4 — DRYING V.S. STRUCTURAL CRACK**

As a precaution, suspected drying cracks should initially be monitored with the same care required for structural cracks. The area should be marked with survey stakes, and monitoring pins installed on either side of the crack to allow recording of any changes in width or vertical offset. (Refer to Chapter 12 Section 12.5-2 for discussion of monitoring methods.) Once satisfied that observed cracking is due to shrinkage or drying, the owner may discontinue monitoring.

Often these cracks will close up as climatic or soil moisture conditions change. If not, it may be necessary to backfill the cracks to prevent entry of surface moisture which could result in saturation of the dam. This can be done by simply filling the cracks with earth and tamping it in place with foot or shovel. In addition, it is recommended that the crest of the dam be graded to direct runoff waters away from areas damaged by drying cracks.

**13.2-8 SEALING RESERVOIR BASINS**

Occasionally, a reservoir will be constructed on pervious terrain. Leakage into the floor of the basin or into abutments may make it difficult to maintain full storage and could endanger the dam if it occurs through the dam's foundation or abutment contacts.

There are two common methods of sealing reservoir basins: blanketing with a compacted clay layer and lining with plastic sheeting. Regardless of the selected method, the process requires adherence to technical engineering standards to insure a valuable result. Thus, for large jobs, the assistance of an experienced engineer is recommended during design and actual construction.

If the basin is to be sealed by placement of an earth blanket, it should be constructed of

compact material, otherwise suitable for construction of an impervious core of the embankment. Blanket thickness should be roughly 10% of the water depth above the blanket and 3 feet as a minimum<sup>1</sup>. If the earth blanket is subject to wave action, a covering of riprap placed upon bedding is recommended.

Preventing seepage by placement of plastic sheeting is possible, but difficult, particularly if only a portion of the basin is to be protected. Liners must be installed according to manufacturers' recommendations if they are to perform properly, and surface preparation is necessary to insure they do not become punctured during installation or use. Portions of the liner subjected to wave action or mechanical injury must be protected with a layer of earth, usually topped with riprap. An earth covering is also recommended to protect the liner from deterioration due to sunlight.

The primary problem with using plastic sheeting to line portions of a reservoir basin is that the plastic must be bonded into the underlying earth so that a cutoff is formed around its edges. If this cutoff is not provided, water may get under the plastic, around its edges, and flow unrestricted to the original point of leakage. (See Figure 13.2-5.)

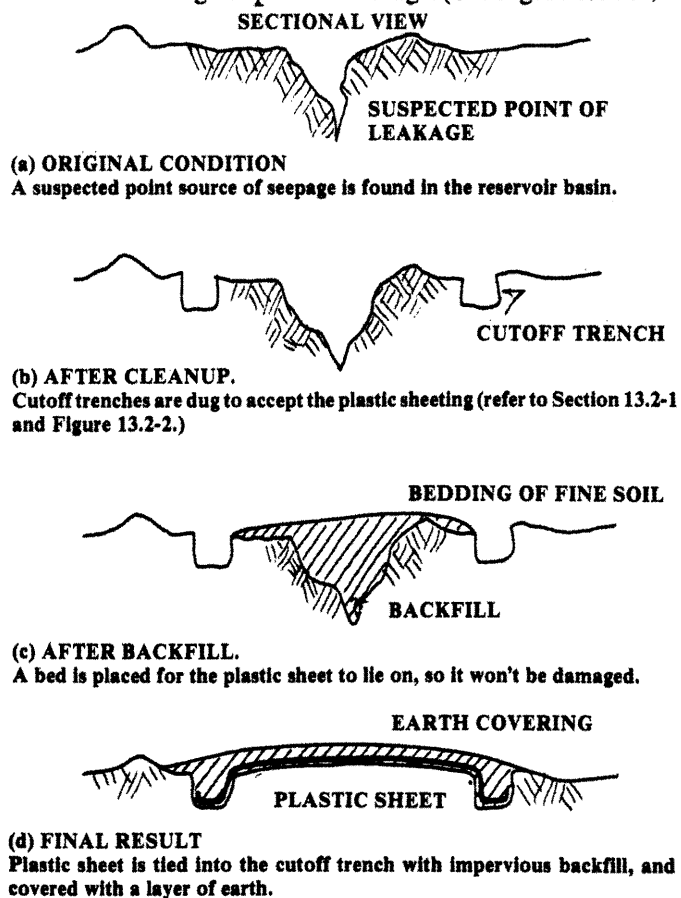

**FIGURE 13.2-5**  
**SEALING RESERVOIR BASINS AGAINST MINOR LEAKAGE**  
**BY USE OF PLASTIC SHEETING**

<sup>1</sup>Design of Small Dams, U.S. Bureau of Reclamation, p. 332.

### 13.2-9 SUMMARY — EARTHWORK MAINTENANCE

This section has provided information useful to accomplish minor earthwork repair, using materials and equipment normally on hand. It is not intended as a technical guide. Serious conditions which threaten the safety of the dam should be repaired under the supervision of an engineer familiar with earthwork. If a condition appears hazardous, the dam owner may request an inspection and guidance from the State Engineer's Office.

### 13.3 RODENT CONTROL

The following chart lists the six rodents that affect dams in Colorado and the methods that can be used to control the rodents. Incidentally, one of the animals is not a rodent but is of the order carnivora — the badger. Control of these animals is important to avoid costly repairs. On some dams in the state beavers or muskrats have initiated tunnels that eventually passed through the entire dam.

Assistance in controlling rodents may be available through the Furbearer Control Land Referral System. This system, sponsored by the Colorado Trappers' Association, is designed to minimize damage caused by water animals, predators, and rodents to dams, livestock, pasture, and croplands. The referral system currently provides assistance to and works in conjunction with the Colorado Cattlemen's Association, Wool Grower's Association, Division of Wildlife, and Department of Agriculture. For further information contact: Mr. Richard J. Pavese, 10995 Halfmoon Pass, Littleton, CO 80127, Phone (303) 979-0360.

Coordination for rodent control should be made with the county extension agent or the Rodent Control Section of the Department of Agriculture, State of Colorado (phone: 303-866-3562). When the rodents have been effectively removed and a program of continued removal has been initiated, the resulting voids must be backfilled and properly compacted. See earthwork section of this chapter.

## CHART 13.3-1 DAMS RODENT CONTROL CHART

### Name of Animal and Description

Beavers — a beaver can be 4 feet long and weigh 30 to 40 pounds. A litter of 2 to 6 young can occur in March or May.



SKETCH 13.3a  
BEAVER

### Harm to Dam

Create dens at upstream slope and into dam. They block spillway with their own dams. The water level could be raised from a blocked spillway.

### Characteristics

Beavers are active day and night. Can stay under water up to 15 minutes. Will drag logs about 100 yards from lake edge and then float logs. Exposure time to predators is increased for long log hauling distances.

### Timing

Any time

### Action Required

No baiting is used. It is best to trap beavers or remove their habitat and food sources such as aspen trees, cottonwoods, and willows.

Muskrats — are 16 inches long (includes tail). Weigh 4 to 5 pounds.



SKETCH 13.3b  
MUSKRAT

Muskrats dig holes on upstream side where good vegetation is located to include cat-tails.

Dig horizontally from water side of a ditch or dam. Dig at points just above saturated soil.

Trapping season is middle of November through March. At higher altitudes trapping occurs in October.

1. Trapping is most effective. Contact private trapper and he will trap muskrats for their pelts. Usually effective method.
2. Put out floater stations with rodent bait on the platform. Use rolled oats.
3. Remove rodents any time if they threaten the safety of the dam.

Richardson's Ground Squirrel — is 10 to 14 inches long, 2 to 4 inches tall, very small ears, weighs 1 pound. Smoke-grey fur.

They dig a hole 4 to 5 feet deep. Diameter of hole 1½ to 2 inches.



SKETCH 13.3c  
RICHARDSON GROUND  
SQUIRREL

Not found in moist areas. Like rocky places. Do not live in timber. Like sagebrush and open country. Feed on grass. Found near Steamboat, Glenwood Springs, Salida and eastern Colorado.  
**ATTRACT BADGERS.**

Poison from opening of spring to middle of July. Short season. Could hibernate in July.

Use 1080 rolled oats, which is treated with highly toxic sodium monofluoroacetate. No prebait needed. Put near diggings or broadcast on the dike. Among toughest to control.

Badgers — are 1½ feet long, weigh 25 to 30 pounds, grey color, stripe on head and neck.

Dig after rodents and make larger hole.

More prevalent in sagebrush country. Do not like moisture.

Any time.

Trap the badgers.



SKETCH 13.3d  
BADGER

**Name of Animal and Description**

Prairie dogs — 10-12 inches long, weigh 1-1/3 to 2½ pounds.

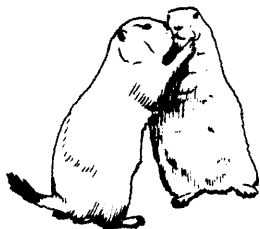

SKETCH 13.3e  
PRAIRIE DOGS

**Harm to Dam**

May burrow at toe of dam causing concentrated leakage of seepage water. May dig into crest causing holes up to 5 inches in diameter.

**Characteristics**

Do not like moisture. Attract badgers who dig bigger hole.

**ATTRACTS BADGERS**

**Timing**

Best in fall or winter.

**Action Required**

Avoid random poisoning, could harm other wildlife.

Use oats as a bait - especially when green food is not available. This is called prebaiting. Then allow lapse time.

Two to ten days later. Repoison.

Thoroughly treat entire colony. Second application. Fumigation can destroy remaining animals.

Strychnine and zinc phosphide are available on the market. Product name - 1080 - under supervision of Rodent Control Section, Colorado Department of Agriculture.

Pocket gophers — About 9 inches long and weigh 1/4 pound.



SKETCH 13.3f  
POCKET GOPHER

Dig shallow holes 3 inches in diameter and 4 to 24 inches deep. Nest chamber usually 8 to 10 inches diameter.

Main food is the roots of dandelions and other undesirable weeds.

Don't like daylight.

Anytime.

1. Herbicides 2, 4-D to kill weeds and dandelions. Partly controls gophers by controlling habitat.

2. Baiting and toxicants.

a. Strychnine-poisoned grain.

b. Gas cartridges and other fumigants.

c. Gophicide.

d. Zinc - phosphide poisoned grain mix with oat groats (without the hull).

**Open hole** — open up hole and put poison bait or trap gophers. Core to plug off daylight. **Probe method** — bait is placed on the runway through a probe hole. **Bait dispenser** — possibly hand dispenser type like corn planter.

3. Trapping for small areas.

4. Exclosure - fencing for at least 12 inches deep for small areas.



## 13.4 CONCRETE STRUCTURES

### 13.4-1 GENERAL INFORMATION

For the purpose of this manual, we will be concerned with the concrete structures which are accessory to the principal dam structure, which may be an earthfill or rockfill embankment.

We will be primarily concerned with:

Upstream slope paving.

Outlet control structures.

Spillways (all types).

Miscellaneous small structures.

Generally speaking, concrete is a reasonably durable material. However, because of the environment in which it is used, concrete does deteriorate over the years, and this process is accelerated by exposure to extreme weather conditions. The most common form of failure is the breakdown of the surface layers of concrete as evidenced by the scaling and pitting which becomes very noticeable.

Another form of failure is indicated by the appearance of large cracks in the concrete. The most common cause for this type of failure is the increase in stress that the concrete is subjected to and usually results from the uneven settlement of the structure or from unequal or excessive earth pressures against the concrete. Generally, these cracks result from unanticipated service conditions, and the concrete does not have adequate reserve strength to accommodate the extra load.

Large structural cracks that develop in concrete will normally require an inspection and evaluation by a qualified structural engineer to determine the cause of the cracking and recommend the most efficient and practical repair procedure.

This manual is directed to the repair and maintenance of concrete structures, but it is advisable at this point to recommend strongly to all dam owners and operators that they get the best possible concrete that they can. This calls for the responsible person to make use of what is generally termed "Quality Control."

Do not shy away from this phrase "Quality Control." The basic idea is to make sure by means of several tests on the fluid concrete when it is delivered to the job site that it conforms to the material as ordered. The tests are not too complicated, but some require special equipment and knowledge of the techniques employed to use them properly.

Following is a list of the concrete qualities that should be checked. However, it should be made quite plain that the actual test procedures are beyond the scope of this manual but are described in several of the publications listed in the bibliography.

Gradation and durability of coarse and fine aggregates (can be certified by the concrete supplier).

Proper water content (requires slump cone and tamping rod for slump test).

Correct air content (requires air meter).

Correct strength (requires casting test cylinders and breaking at a later date).

These are the major factors to be considered in order to get top quality durable concrete. Top quality concrete pays off in longer service life and reduced maintenance costs.

The basic idea in attaining durable concrete is stated above. Start with top quality concrete. However, concrete, once it is in place is under constant attack by weather, chemical action, and wear. Good concrete properly placed and finished should have a dense, durable surface, made as water-resistant as possible, which will help slow the deterioration process.

When concrete in a very moist atmosphere is exposed to repeated cycles of low temperatures at night (freeze) and warming temperatures during the day (thaw), there is a good chance for the surface of the concrete to start breaking up. This condition results when any moisture which has penetrated the porous concrete surface freezes and turns to ice. Then the expansion of the ice tends to loosen or dislodge particles of the concrete. As this freeze/thaw action continues over a period of many years, the concrete slowly disintegrates.

Several things can be done to slow or stop this disintegration. First, good quality concrete with a dense surface is the basic requirement. Next, if the concrete surface is showing signs of breakup, then one of several treatments should be applied to the affected areas. There are various products available that can be used to seal and protect the surface. Two general types of coating materials are available for this purpose. The first type consists of single-component liquids which can be applied directly to the concrete surface by brushing or spraying. The second type are the two-component materials which have to be job-mixed just prior to applying and have to be used immediately. These generally are the epoxy compounds which require the addition of an activator (catalyst) just prior to

use. The two-part epoxy compounds have an added advantage when used to patch areas that are deeply eroded. Clean, hard, uniformly sized sand can be mixed with the epoxy compound to increase the bulk of the mix which will speed up the patching operation. The service life of these coatings varies widely among the different products and in selecting a product, consideration should be given to the frequency of replacement (service life).

The effects of chemical action are very similar to those of weathering in which the surface disintegrates and peels off. Chemical attack can come from several different sources, such as waste water from sewage treatment plants, water draining from old mines and waste dumps, and naturally occurring contaminated waters such as those from mineral springs.

Some soils can react adversely with the cement and rock in the concrete and cause it to break up prematurely. These soils are found in different locations throughout the western half of the United States. They have high sulfate content (calcium, magnesium and sodium sulfate); these soils are usually known as alkali soils. In addition, some of the ground waters found in this area carry a high percentage of dissolved sulfates which will attack some concretes.

The chemical reaction of these sulfates with the cement matrix produces new compounds which are accompanied by considerable expansion and disruption of the matrix. This usually causes pop-outs and deep pockets in the concrete as the aggregate is loosened and displaced.

To protect concrete structures from sulfate attack, two approaches are possible. For all new concrete, use either Type II cement for moderate sulfate levels or Type V cement if the sulfate level is high. For concrete already in place not made with Type II or V cement which might be subject to sulfate attack, the best defense is to coat the exposed surfaces with a material which will seal the surface against the entrance of moisture. Some of the products available for this purpose are coal tar enamels, silicone sealers, and different types of epoxy sealers. For older concrete which is showing signs of breakup caused by sulfate attack, the procedures to be used for the repair of surface defects are the same as those used for the repair of weathering defects.

Another form of chemical attack is alkali-aggregate reaction; this refers to the condition in which some types of aggregates develop an adverse reaction with the other constituents in the concrete. This problem is

discussed more fully in the section on concrete dams.

Protecting concrete from erosion damage is a little more complex because adequate protection involves more than coatings or paint. The more common forms of erosion damage are loss of concrete worn away by abrasive materials carried in suspension by flowing water, wind blasting which is caused by high velocity winds carrying sand or small-sized gravel particles which wear away the surface, and damage caused by the impact of floating ice. Naturally, the best protection against these attacks is to have strong, durable, dense concrete at all areas of impact. This is also true for conditions in which chemical attack and severe weathering conditions can occur.

Erosion damage can be repaired by the use of high density, reinforced epoxy compounds which are used to repair or rebuild the damaged surfaces. In areas where heavy ice damage occurs, it may become necessary to sheath the exposed concrete surfaces and edges with sheet steel and angle iron in order to deflect the ice as it builds up.

#### 13.4-2 REPAIR OF DETERIORATED AREAS, SURFACES, JOINTS

As noted above, deteriorated or damaged concrete has many causes. The proper repair of these areas depends a great deal on the basic cause of the failure. The shallow areas with depths up to 2 or 3 inches can usually be repaired by skin patches, while deeper, more extensively damaged areas will require pouring new concrete and may even require formwork in order to restore the original shape.

The general requirements for most concrete repairs are to chip out and remove all loose material down to sound concrete. The edges of the area to be patched should be trimmed square with the surface or even slightly undercut so as to key the patch in place.

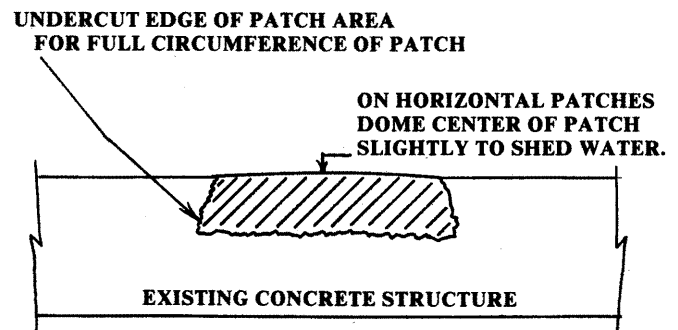

FIGURE 13.4-1 — CONCRETE PATCH

Before applying the patching material, wash the area clean with clear water, leaving the area in a surface-damp condition. Prepare the patching material, which is usually a mixture of sand and cement in proportions varying from 1:1 to 3:1, with sufficient water added to make a thick paste. **The use of bonding additives is strongly recommended.** There are many brands of these products available and they can usually be obtained from hardware stores or concrete suppliers.

The patch material should be well worked into the repair area so as to assure complete filling with full contact with the original, sound concrete. The surface of the patch should be finished even or slightly above the surface of the original concrete.

#### 13.4-3 **BONDING ADDITIVES**

In all concrete patching work, the use of bonding additives is strongly recommended. These products, when properly used, help to insure a durable, water-resistant patch that stays in place and is highly resistant to weathering action.

There are two general classes of bonding additives: latex-based and epoxy-based. The latter are usually of the two-component formulation. For most work, the latex compounds are the easiest and most convenient to use since they are non-toxic and do not require special equipment for mixing and applying. Some of the tradenames under which these products are sold are Sikabond (Sika Chemical Corp.), Proweld (Protex Industries), Weldcrete, etc.

For special patching problems such as continuously wet areas, overhead areas, and others, the epoxy-type bond agents are far more satisfactory. There are certain problems in handling these epoxies, such as toxic fumes, materials irritating to the skin and eyes, fast-setting, etc. However, the products can be handled safely when the proper precautions are used. Information on available products can be obtained from the dam owner's concrete supplier.

A very important part of the repair procedure is to keep the newly patched area moist for at least three days. This is necessary in order to insure full strength development of the cement in the patch material. The best way to accomplish this is to coat the patch area with a spray-on curing compound which seals the existing moisture into the patch. It is also possible to cure the patch adequately by keeping it moist for the required period of time. This can be done by covering the patch with wet burlap and keeping it wet, or by using a lawn sprinkler or soaker hose connected to a dependable source of water. To

insure a long, satisfactory, service life for the patch, all the steps of the above procedure must be followed.

#### 13.4-4 **CONCRETE SLOPE PROTECTION**

Where dams are constructed with concrete paving on the upstream slope for wave protection, it sometimes becomes necessary to repair or replace whole slabs or portions of slabs which have been damaged or destroyed. The breakup of these slabs starts with the loss of the joint filler material which allows wave action to wash out the underlying embankment material through the open joints. Repeated wave cycles with the additional loss of soil material eventually leads to the complete undermining of the slab and its ultimate collapse.

When the supporting soil becomes saturated with the water which enters through the open joint, it has a tendency to flow downhill to the most convenient point of exit. This is why many slabs fail in pairs, one on each side of the open joint. The water flushes soil particles from under the slabs in approximately equal directions, forming cavities or pockets. The technique for locating these cavities under the concrete slab(s) is discussed in Chapter 4.

#### 13.4-5 **REPAIR PROCEDURES**

The repair procedure for these damaged slabs starts with the removal of all or part of the slabs affected. The cavities or pockets should then be backfilled to the original embankment slope line with well compacted layers of earth. The last step is to pour concrete for the new slabs, following the procedures for finishing and curing as outlined above.

The following procedure is recommended for the proper preparation and sealing of slab joints and large slab cracks. First of all, check the area adjacent to the joint or crack to make sure no subsurface cavities or pockets exist. Then clean out all dirt and vegetation such as weeds and grasses from the joint or crack. Chip out all loose or disintegrated concrete. In extreme cases where crack sealing compounds have been used previously, it may become necessary to chip out the old compound and finish cleaning by sandblasting the crack/joint and the surrounding area. All loose material should be removed from the crack or joint by blowing it out with compressed air. The clean dry crack or joint should then be filled with a high quality joint sealer compound. If possible, pick a warm, dry day to do the sealing operation.

For dams with upstream concrete slope paving, the proper maintenance of the sealing material in the slab joints and cracks is very important in preserving the structural stability and safety of the dam. It is a very important part of any good comprehensive maintenance program for a dam.

#### 13.4-6 DRAINAGE FACILITIES

Drains associated with concrete structures have two important basic functions. One is to prevent or reduce the buildup of excessive ground water pressure (hydrostatic pressure) and the second is to drain excess moisture from the backfill material around and behind structures and walls. Proper drainage helps to consolidate and stabilize these soil materials.

Normally drains are usually installed as a part of the original construction work. Thus, they become a part of the routine inspection process when they are checked for proper operation.

It is when these drains malfunction that it becomes a critical maintenance problem. Those drains which are an integral part of the embankment (i.e. toe, finger, and chimney drains) cannot be repaired or replaced, except with great difficulty. However, drains which are used under and around structures such as spillway channels, retaining walls, and other minor structures can usually be re-excavated and repairs made. Also, it sometimes becomes apparent that additional drainage might be needed for a specific area. All work of this nature should be done under the guidance and control of a well-qualified professional engineer registered in Colorado.

### 13.5 STEEL STRUCTURES AND METAL COMPONENTS

Accessory structures at a dam site usually contain many metal components. Steel parts and structures are by far the most common among metal components. Brass and aluminum are sometimes used in secondary components. Examples of metal structures include outlet pipes, operating and control structures such as gates; valves, trash racks, security structures such as railings, fence, etc.; maintenance and access structures such as ladders, bridges, etc. Accessory structures are indispensable to the successful and safe operation of the dam. They should be maintained in a good condition at all times. Causes for replacement or repair are discussed and useful maintenance procedures are listed below.

#### 13.5-1 CORROSION

There are two basic types of corrosion. The first is rusting, which means that the metal particles combine with oxygen to form oxides. (This usually refers to iron or ferrous alloys.) The second is galvanic corrosion which means that the metal particles are loosened and carried away by electric currents.

Painting is the most commonly used method to prevent rusting. Paint should be applied only on a clean, dry surface. Sand blasting or grit blasting is recommended to remove rust and other tough deposits. Water, solvent, wire brush, or flames may also be used to prepare the surface. Brief discussions on painting will be presented in Sections 13.5-4 through 13.5-6. For more detailed information, consult the **Paint Manual**, which is published by the U.S. Bureau of Reclamation.

Cathodic protection may be used to minimize or prevent galvanic corrosion. Some specific ideas will be discussed in Section 13.5-7. Actual application of cathodic protection should be performed under the direction of a corrosion engineer. A dam owner can minimize galvanic corrosion by avoiding the mixing of different kinds of metal in the same structure. For example, aluminum or copper screws should not be used to fasten steel parts. When contact between different metals is unavoidable, good insulation at the contact surface should be provided.

Rust scales and other impurities should be thoroughly cleaned from metal surfaces before paint is applied. Care should also be taken to prevent metal dust, sand, or other foreign material from being mixed with paints. Otherwise, the painted surface may develop pin-hole corrosion, especially when it is in contact with the soil. The life of a buried pipe can be prolonged if it is wrapped in moisture-impermeable plastic sheets to insulate it from stray electric currents.

#### 13.5-2 REPLACEMENT AND REPAIR

Broken or deteriorated members of a metal component should be replaced or repaired as soon as possible before the defective part has a chance to cause subsequent damage to other parts of the structure. Broken brass or aluminum parts should be replaced. Steel parts may be welded. Reinforcing or repairing a broken part by fastening or screwing on an extra piece of metal rod or plate is not recommended because this is only temporary and will soon fail.

Welding of steel parts may be achieved by the gas or arc welding process. A skillful and knowledgeable welder should be employed, because improper procedures will result not only in a weak welded joint but also weakened strength of the steel in the vicinity of the weld.

#### 13.5-3 GENERAL PRINCIPLE OF SURFACE PROTECTION

The exposed surface areas of metal components are usually protected with an appropriate type of paint or other protective materials. The protective coating should be regularly inspected to determine that it is not

suffering from blistering, flaking, pinholes, seediness, cracking, chalking, abrasion, erosion, or cavitation. Thorough inspection of protective coatings should be performed at least once a year. Under ordinary circumstances, a low power magnifying glass, a knife, a thickness gauge, a pit depth gauge, and a flash light are all the tools needed for inspection.

During the inspection, note the number and distribution of rust spots and pits. Measure the size and depth of the pits. Find out if the surface coating is still in good condition and has a good bond to the protected surface. Special attention should be paid to hard-to-reach locations. Adequate lighting for the inspection is very important. Keep in mind that pitting-type corrosion is more damaging than generalized minor rusting. If the blistering, flaking, cracking, chalking, etc., do not penetrate to the lower paint coat, local touch-up or additional coats of painting should be enough to restore integrity and prolong useful life of the protective coating. If the metal surface is exposed and the quality of the protective coating has deteriorated, then complete removal of old paints may be necessary and new protective coating re-applied.

Before touch-up painting or an additional new coat is to be applied, the old paint should be thoroughly cleaned with water and detergent. Just before the touch-up or repainting, the surface should be freed of oil, grease, dust, moisture, and other impurities. If large areas need to be cleaned, high-pressure water blasting or steam cleaning may be employed. If detergent is used in the cleaning, thorough rinsing is required. The surface should be dried before repainting is undertaken.

As a rule, the same type of paint material as the existing coat should be used. Coal-tar enamel and vinyl resin should never be applied over other types of coating, nor should a lacquer-based paint be used over a linseed-oil paint. Coal-tar epoxy paint may be used to repair defects in coal-tar enamel and vinyl paints.

Touch-up or preventive maintenance painting of metal structures should be performed as often as is necessary. For example, after 10 years of satisfactory service, a vinyl paint coating should be repainted even though there is still no serious deterioration. In the long run, this may prove to be more economical than allowing the existing paint to deteriorate, which would call for a complete removal of the old paint and repainting in a few years. When painting with volatile thinners or cleaning with solvents in enclosed

areas, adequate ventilation should be provided. Faulty electrical equipment or sparking tools should never be used. Furnace pilot light should be turned off; otherwise, there may be an explosion.

#### 13.5-4 **PAINT PROTECTION FOR AIR EXPOSURE**

Metal works, such as bridge components or handrailings which are exposed to outside atmosphere, can be protected with enamel paints. Normally, a coat of red-lead priming paint is applied to increase resistance to corrosion. A finish coat of aluminum paint, enamel paint, or epoxy resin paint is then applied.

For metal work exposed only to an indoor atmosphere and not subjected to excessive condensation, an enamel or aluminum paint applied over a coat of suitable primer will provide adequate protection. Priming paint used under enamel or aluminum paint is usually of the quick-drying type containing red-lead as rust inhibitor.

#### 13.5-5 **PAINT PROTECTION FOR AIR AND WATER EXPOSURE**

Spillway gates, checks, or turnouts, etc., are either partially or intermittently exposed to the air or water. They can be protected with vinyl resin paint of phenolic red-lead and aluminum paint system. Cold-applied coal-tar paint may be used if there is only minimal exposure to sunlight. Zinc coatings may also be applied to prolong structure life. Zinc coating may be applied by hot-dip galvanizing, metallized spraying, organic zinc-pigmented coating or inorganic zinc-pigmented coating.

#### 13.5-6 **PROTECTION FOR UNDERWATER EXPOSURE**

Trash racks, high-pressure gates, storage tank interiors, penstocks, outlet conduits, siphons, and other underwater metal works are normally exposed to water. Exterior surfaces of buried pipes are also exposed to high moisture most of the time. These underwater metal works may be protected by various protective coatings cited below:

- a. Hot-applied coal-tar coating. There are two types in common use: Coal-tar enamel and coal-tar pitch. A synthetic resin primer is recommended for coating trash racks. The easiest method of application is by dipping, especially where many racks are involved. For coal-tar enamel, type B synthetic resin primer is recommended. (Refer to American Water Works Association Standard C-203.) Coal-tar enamel is suitable for use on the interior surfaces of penstocks and outlet pipes. In order to assure a smooth finish, the spinning process is recommended.

(This is a shop process whereby the pipe is spun while the coal-tar enamel is being applied.) For small structures, hand application may be acceptable if the job is done carefully.

- b. Hot-applied coal-tar enamel tape. The coal-tar enamel tape is especially suitable for coating joints and wrapping valves.
- c. Cold-applied tape. With this form of protection, it is not easy to assure void-free wraps over rough surfaces. Extra care must be exercised to prevent damage to the tape during handling and backfilling.
- d. Cold-applied coal-tar coating. When coal-tar pitch is mixed with solvents and fillers, the resulting coal-tar paint may be applied with a brush or a sprayer without heating.
- e. Coal-tar epoxy paint. This is obtained by mixing coal-tar and epoxy. Immersion life may be up to 20 years or longer. Exposure to sunlight, however, will cause chalking. The coal-tar epoxy can be applied to gates, valves, etc.
- f. Vinyl resin paint. This may be used for interiors of water tanks and steel pipe that will be empty in winter time and subjected to low temperatures.
- g. Cement mortar. This may be used as a protective interior coating for steel pipe, especially where flow velocity is not expected to be higher than 20 feet per second. Minimum lining thickness of about 5/16 inch is recommended.
- h. Hot-dip asphalt coating. This is not generally considered to be as effective as coal-tar coating in protecting steel pipe from corrosion. But it is an inexpensive shop treatment.
- i. Coatings applied under water. When water and moisture cannot be excluded from a painting site, special epoxy type paint will have to be used. Epoxy paints or gel for underwater application are commercially available, but they are relatively expensive.

For more specific information, talk to a specialist or read the **Paint Manual**.

### 13.5-7 CATHODIC PROTECTION

If the repainting of a steel structure is impractical, as in the case of the exterior surface of a buried steel pipe, then cathodic protection may be used to arrest or delay the progress of corrosion. Basically, cathodic protection consists of making the electric potential of soil positive to the potential of the steel work being protected.

There are two methods of applying cathodic protection to underground steel pipes. In the galvanic anode method, zinc or magnesium anodes are packed or buried with a backfill of gypsum, bentonite clay, and sodium sulfate. The anodes and the steel pipe are then connected with copper wires to complete the circuit. The zinc or magnesium will corrode away and has to be replaced. The general arrangement is indicated by the accompanying sketch.

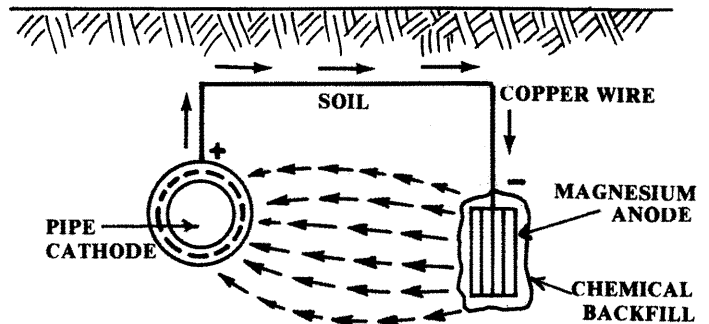

**CATHODIC PROTECTION: GALVANIC ANODE**  
(From: Joseph F. Bosich, *CORROSION PREVENTION FOR PRACTICING ENGINEERS*, Barnes & Noble, 1970)

It might be well to mention the conditions which determine which system to use.

In the second method of cathodic protection (the rectifier-ground beds), a d-c current is impressed on the structure to be protected so that the structure becomes the cathode and groundbed of the rectifier anode, as shown by the following sketch. The groundbed consists of an array of carbon, graphite, aluminum, high-silicon cast iron, or scrap iron anodes. The rectifier is used to transform a-c current into d-c current which is impressed into the earth at the groundbed. The structure (e.g., a steel pipe) is connected to the negative pole of the rectifier.

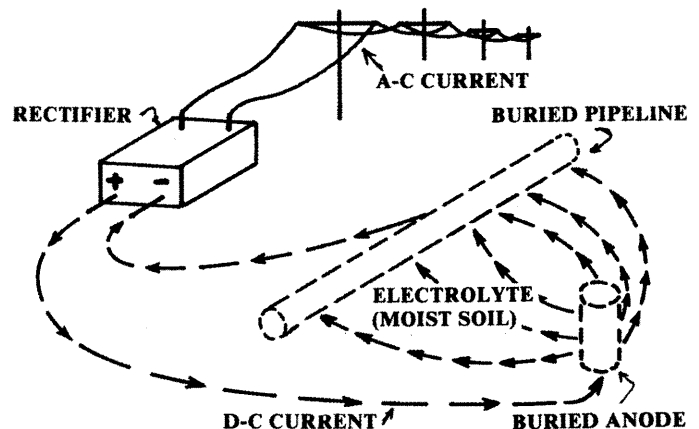

**Field Installation of IMPRESSED-CURRENT (Rectifier-groundbeds) cathodic protection.**

(From: **PAINT MANUAL**, U.S. Bureau of Reclamation)

The rectifier-ground bed method is used when an a-c power supply is available, and where larger current outputs are required for protection of a large structure, or where high-resistivity soil is encountered.

## 13.6 OUTLET GATES — MECHANICAL MAINTENANCE

### 13.6-1 INTRODUCTION

As discussed in Chapter 9, the operability of a dam's outlet works is essential to the safe and satisfactory operation of the dam. Release of water is essential to realize the beneficial use of stored water. On reservoirs used for recreation, fish propagation, or other uses for which release of water is not required, an operable outlet, as with all dams, provides the only means for the emergency drawdown of the reservoir, thereby being essential to the safety of the dam.

If the routine inspection of the outlet works, discussed in Chapter 9, indicates the need for maintenance, the work should be accomplished as soon as access to the subject areas can be gained. Postponement of maintenance could cause damage to the installation, significantly reduce the useful life of the structure, and result in more extensive and more costly repairs when finally done.

### 13.6-2 CYCLING OF OUTLET GATES

The simplest procedure which can be used to insure the continued operability of the outlet gates is to cycle all gates through their full operating range at least once and preferably twice annually. Many gate manufacturers recommend cycling gates as often as four times each year. As cycling of gates under full reservoir head could result in large outlet discharges, it is recommended that gate cycling be scheduled during periods of low storage. If this cannot be done, cycling should be done during periods of low stream flows. If large releases are anticipated, outlet testing should be done only after coordinating releases with water administration officials and notification of downstream residents and water users.

Cycling of the gates prevents the buildup of rust on contact surfaces of the operating mechanism and the possible seizure of the operating mechanism as contact surfaces rust together. During this cycling procedure, the mechanical parts of the hoisting mechanism, including drive gears, bearings, and wear plates, should be checked for adverse or excessive wear. All bolts, including anchor bolts, should be checked for tightness. Worn and corroded parts should be immediately replaced. Mechanical and alignment adjustments should be made as necessary.

Note should be made of operating characteristics of the gate mechanism. Rough, noisy, or erratic movement of the gate or gate mechanism could be the initial signs of a developing problem. The cause of detected operational problems should be investigated and corrected immediately.

### 13.6-3 OPERATING OUTLET GATE

When operating the outlet, excessive force should not be needed nor should it be applied to either raise or lower the gate. Most hoisting mechanisms are designed to operate satisfactorily with a maximum force of 40 pounds on the operating handle or wheel. If excessive force is needed, problems may have developed with the outlet installation which are causing binding in the mechanical system. The application of excessive force may irreversibly bind the gate or damage the outlet works. (See Figure 13.6-1.)

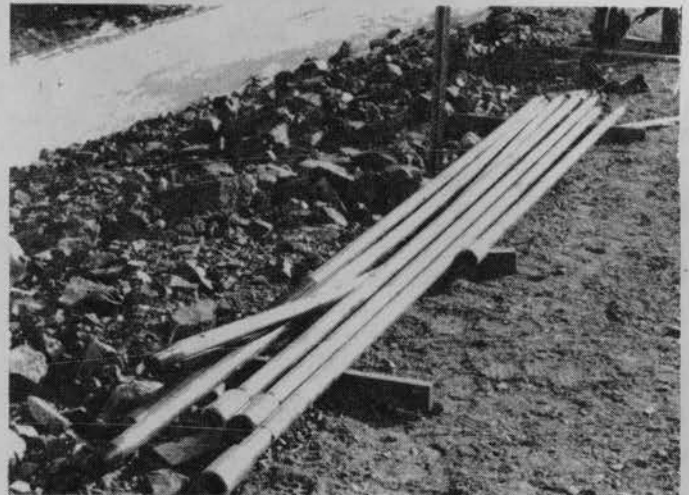

PHOTO 13.6-1 — BENT OUTLET STEM

Two-and-one-half inch diameter stainless steel stem removed from outlet installation. Stem was bent due to excessive force applied to operating mechanism while attempting to close outlet gate.

It is recommended that the gate be worked up and down repeatedly in short strokes until the binding ceases. Investigations should also be made to determine the cause of the operational problem. The cause of the problem should be corrected as soon as possible to assure the continued operability of the gate.

In cases where the gate does not properly seal in the closed position, debris may be lodged under or around the gate leaf or frame. The gate should be raised a minimum of 2 to 3 inches to flush the debris and an attempt made to reclose the gate. This procedure should be repeated until proper sealing is achieved. The manufacturer's representative or an engineer experienced in gate design and operation should be consulted if operational problems persist.

### 13.6-4 MAINTENANCE OF OPERATING MECHANISM

As with any equipment, proper routine maintenance and lubrication is essential for the continued operability of the outlet and will significantly extend the useful life of the installation.

The outlet gate operating mechanism should be well lubricated at all times on all wear surfaces. Hoist mechanisms should be lubricated as per manufacturers' specifications. Proper lubrication will reduce wear in the hoist and will protect the mechanism against the adverse effects of weather by preventing water from entering the mechanism and causing internal corrosion.

Oil-filled stems, where the gate operating stem is encased in a larger surrounding pipe, should be checked semi-annually to assure maintenance of the proper oil level. Negligence of this item could allow water to enter the encasement pipe through the lower oil seal and could cause drying out of the upper and/or lower seals. This could lead to the corrosion of both the gate stem and interior of the encasement pipe.

All exposed, bare ferrous metal on the outlet installation, whether submerged or exposed to air, will rust. If corrosion is to be prevented, exposed ferrous metals must either be painted or heavily greased. If painted, the

paint and application method used will vary to suit the particular circumstances. Various paint applications are discussed in Section 13.5 of this manual. A useful additional reference in deciding the particular paint to use for a specific circumstance is the **Paint Manual**, third edition, published by the U.S. Bureau of Reclamation. This publication discusses the various types of paint available, necessary preparation, primers which should be used, and methods of application. This manual is a valuable and useful reference.

When repainting areas, steps should be taken to assure that paint does not get on gate seats, gate wedges, gate stems in the reach where the stems pass through the stem guides, or other friction surfaces where paint could cause binding on any portion of the operating mechanism. (See Figure 13.6-2.) Heavy grease should be used on surfaces where binding can occur. As rust is especially detrimental to contact surfaces, removal of existing rust should be done prior to the periodic application of grease.

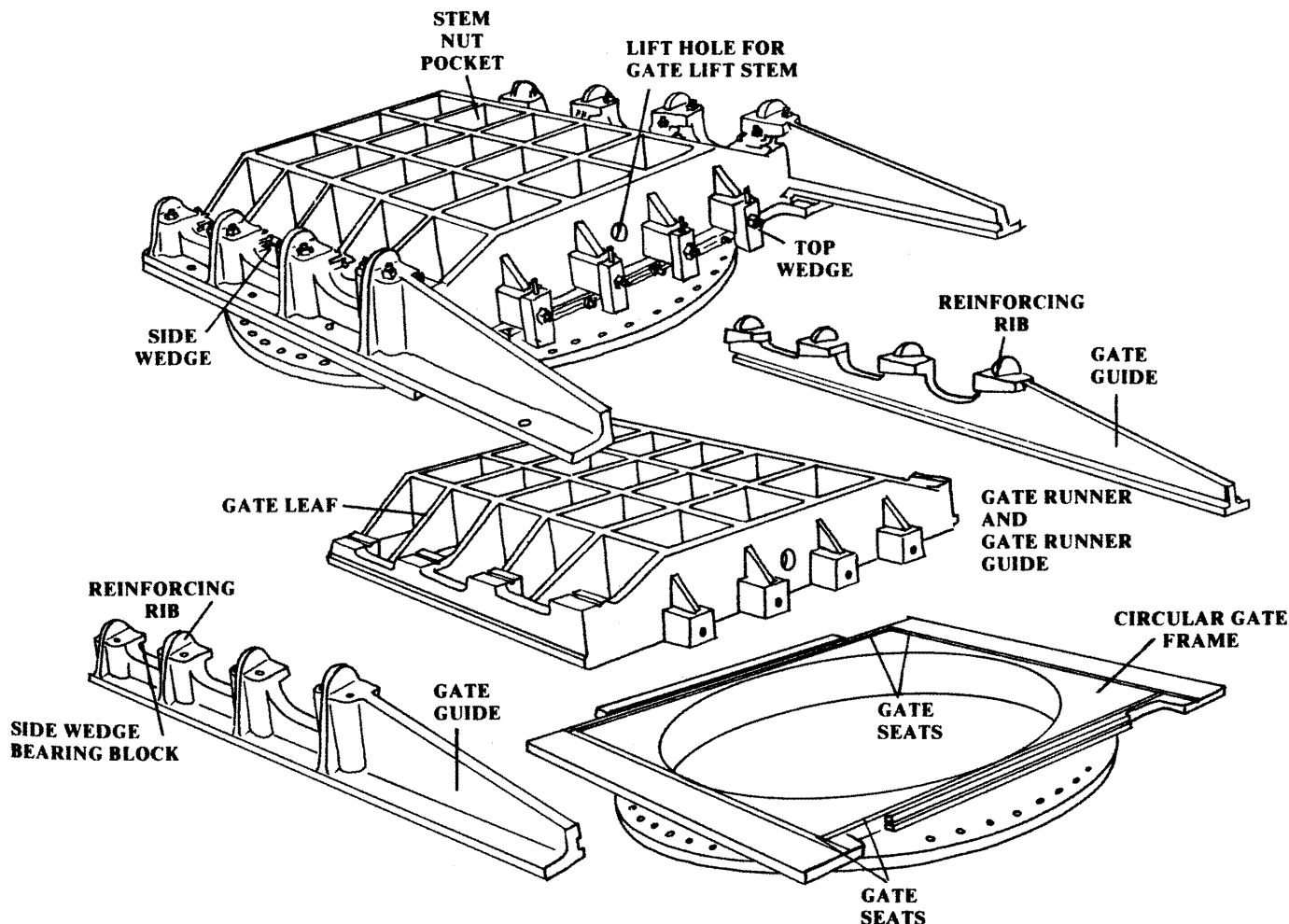

FIGURE 13.6-2 — BASIC COMPONENTS OF AN OUTLET GATE INSTALLATION



Metal used in gate seats is usually brass, stainless steel, bronze, or other rust-resistant metals. Older or smaller gates may not be fitted with seats, making them susceptible to rusting at the contact surfaces between the gate leaf and gate frame. Cycling of the gates should prevent excessive rust buildup or seizure in these cases.

### 13.6-5 OPERATING STEM ALIGNMENT AND SUPPORT

It is imperative to the satisfactory operation of the outlet that the gate stem be maintained in proper alignment with the gate and hoisting mechanism. Proper alignment and support is provided by an adequate number of stem guides, properly spaced along the length of the stem. Stem guides are brackets or bearings, through which the operating stem passes, that restrict the lateral movement of the stem outside the plumb line between the gate and hoist. (See Figures 13.6-3 and 13.6-4.) Stem guides prevent bending or buckling of the stem, when the stem is subjected to compression as the gate is being closed. (See Figure 13.6-5.) The stem guides shorten the unrestrained length of stem, making it capable of withstanding higher compressive forces without buckling.

The alignment of the stem should be checked during routine inspections. Stem alignment may be visually checked by sighting along the length of the stem. Accurate alignment checks may be accomplished by stretching a stringline from a point near the top of the stem just below the hoisting mechanism to a corresponding point near where the stem enters the gate leaf. The two points should be a measured distance "D" to the side of the stem, as shown in Figure 13.6-6.a. The stem, at all points along its length, should be the same distance "D" from the stringline.

A second stringline should then be installed in a similar manner upstream of the stem to check alignment in the upstream/downstream direction, as shown in Figure 13.6-6.b.

While checking alignment, all gate stem guide anchors and adjusting bolts should be checked for tightness. A loose guide bracket provides no support to the stem and could cause buckling of the stem at the loose bracket.

If during normal inspection, the stem is found to be out of alignment, steps should be taken to realign the affected brackets. The gates should be completely lowered to the closed position and all tension or compression taken off the stem. The misaligned gate stem guides should be loosened and should be free to move. The hoisting mechanism should then be operated to raise the gate to put the stem in tension, thereby straightening

it, but the gate should not be opened. The affected guides should then be restraightened in a position where the stem passes exactly through the center of the guides.

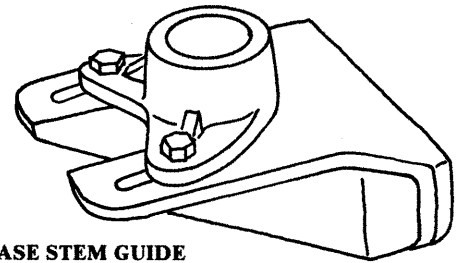

**SOLID CASE STEM GUIDE MOUNTED ON WALL BRACKET**

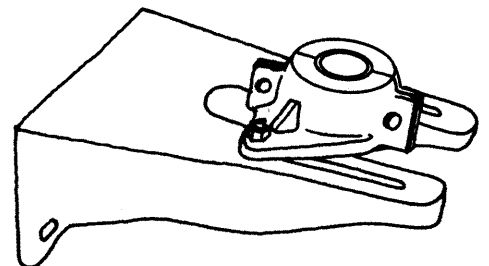

**SPLIT CASE STEM GUIDE MOUNTED ON WALL BRACKET. THIS GUIDE HAS A SOLID METAL BUSHING INSERT.**

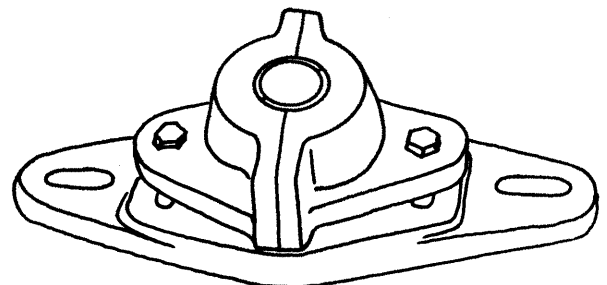

**SPLIT CASE STEM GUIDE WITH SPLIT METALLIC BUSHING INSERT. BUSHING INSERTS ARE USUALLY BRONZE OR NON-METALLIC.**

**FIGURE 13.6-3 — VARIOUS EXAMPLES OF STEM GUIDES**

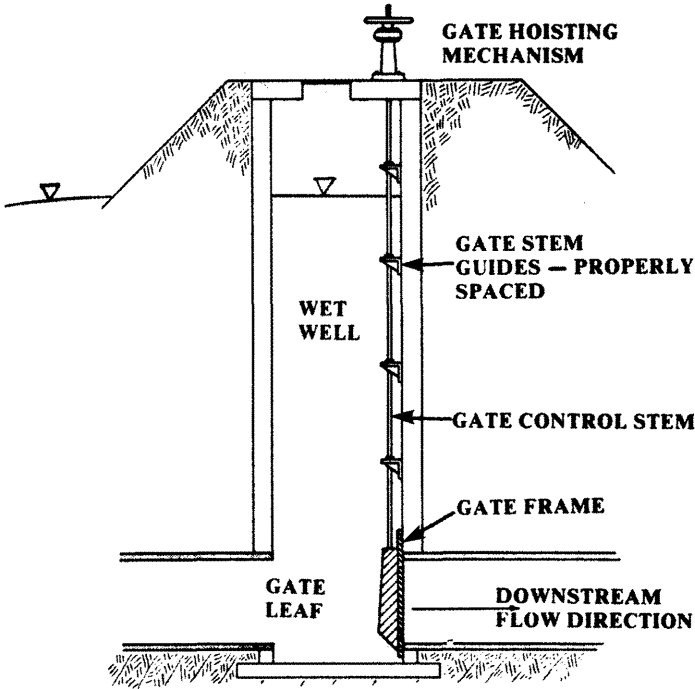

FIGURE 13.6-4 — WET WELL OUTLET INSTALLATION

This sketch represents a properly designed and installed outlet mechanism. Adequate numbers of stem guides at the proper spacing assure the rigidity of the control stem.

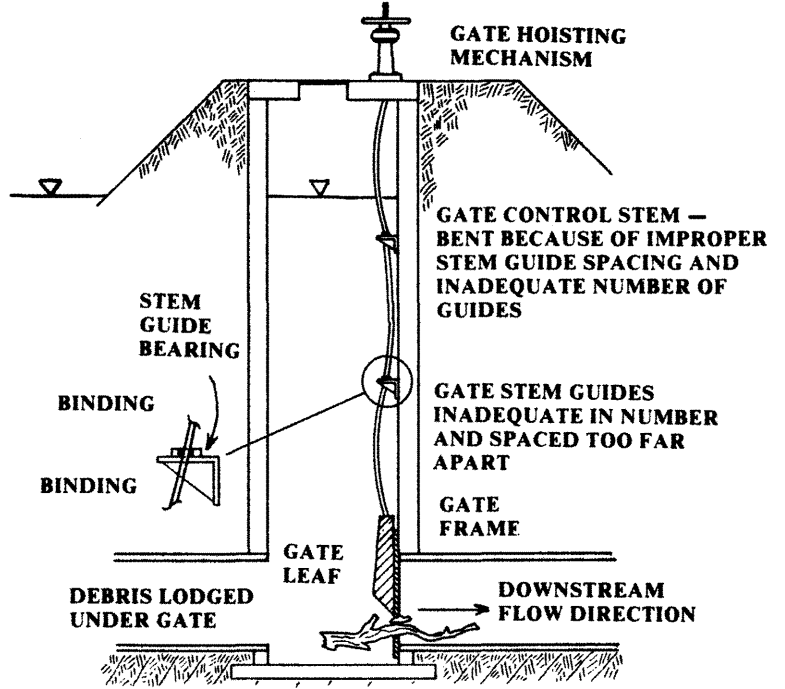

FIGURE 13.6-5 — WET WELL OUTLET INSTALLATION

This sketch represents an improperly designed and installed outlet gate mechanism because of the inadequate number of stem guides and improper spacing between guides. Excessive force used to attempt to close the gate (see Section 13.6b) has resulted in bending of the control stem because of inadequate stem support. Operational problems are further complicated as the bent stem binds on the stem guides because of the misalignment of the stem relative to the guide bearing.

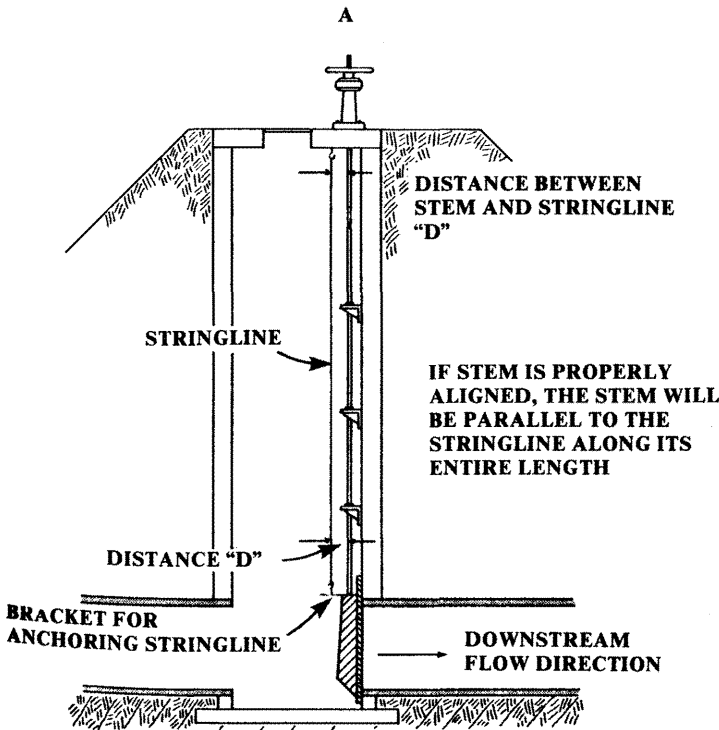

FIGURE 13.6-6.a — CHECKING STEM ALIGNMENT IN THE UPSTREAM/DOWNSTREAM DIRECTION

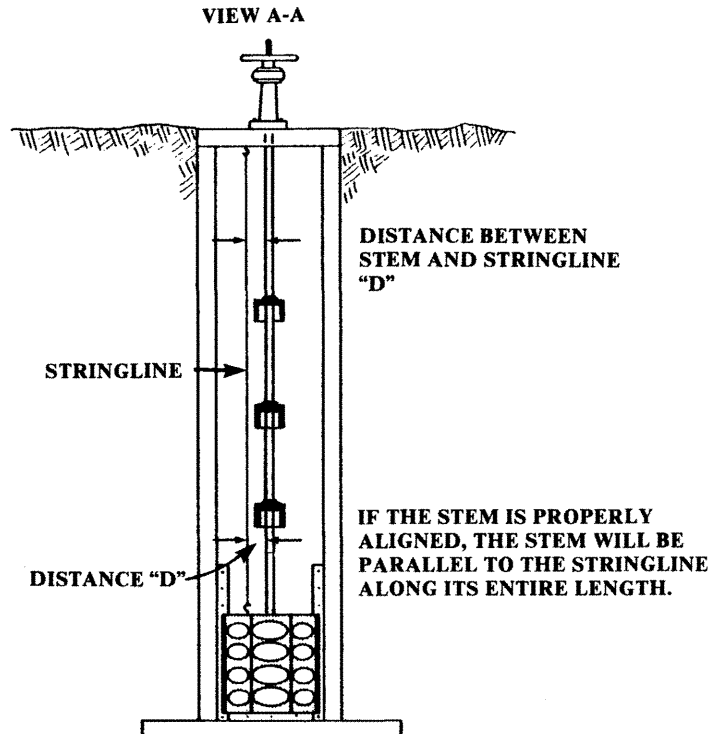

FIGURE 13.6-6.b — CHECKING STEM ALIGNMENT IN THE LEFT/RIGHT DIRECTION.

Excessive binding of the stem in the stem guides will result if the guides are not properly aligned with the stem.

### 13.6-7 **OUTLET GATE ADJUSTMENTS**

Many outlet gate installations are equipped with wedge systems that allow the gate to be adjusted to seal tightly. (See Figure 13.6-2.) These wedge systems force the gate leaf tightly against the gate frame as the gate is lowered into a fully closed position. This causes a tight contact between the gate seats on the gate leaf and the gate seats on the gate frame. Through years of use, the gate seats may become worn, causing the gate to leak an increasing amount. If the installation is equipped with a wedge system, the leakage may be substantially reduced or eliminated by the proper readjustment of the wedges.

Adjustment should **never** be attempted by a novice. As adjustment of these gates is complicated, inexperienced personnel can cause extensive damage to the gate installation by improperly adjusting the gate. Improper adjustment could cause premature seating of the gate, possible scoring of the gate seats, binding of the gate, gate vibration, leakage, uneven closing of the gate, or damage to the wedges or gate guides. **Always** employ experienced personnel to perform these adjustments. Consult a gate supplier or manufacturer to obtain names of people experienced in gate adjustment.

### 13.6-8 **SEASONAL OPERATION OF THE RESERVOIR**

Ice can exert excessive force on, and cause significant damage to, an outlet gate leaf. Storage levels in the reservoir during the winter should be such that ice cannot develop against the gate. To prevent ice damage, storage should either be at a level significantly higher than the gate if storage is carried through the winter, or if the reservoir is to remain empty over the winter months, the outlet should be fully opened. If operation requires the water level to move across the gate, a bubbler or other anti-icing system will be required.

### 13.6-9 **SUMMARY**

Regular cycling of the outlet gates will prevent the accumulation of rust on contact or bearing surfaces and prevent the possible seizure of the outlet operating system. Cycling as well as periodic scheduled maintenance on various components of the outlet operating system will assure the continuing satisfactory and safe operation of the outlet and will significantly lengthen the useful life of the outlet installation.

In many cases, operation of the mechanical portion of the outlet is dependent on hydraulic systems and/or electrically powered drive units. Maintenance of the systems is important and is covered in subsequent sections of this chapter.

## 13.7 **ELECTRICAL SYSTEMS**

### 13.7-1 **INTRODUCTION**

The use of electrical devices on most of the dams in Colorado is limited. When a 12-inch diameter slide gate is opened at night, the only electrical item needed is a flashlight. Therefore, electrical systems will be discussed briefly.

### 13.7-2 **USE OF ELECTRICITY**

In general, electricity is used on dams for the following:

Provide lighting

Operate outlet gates

Operate recording equipment

Operate spillway gates

Operate other electrical equipment like elevators or cranes

When demand is placed upon these pieces of equipment, it is hoped they will respond with a **sound** of a motor running, which is comforting to the human ear during an emergency.

### 13.7-3 **PREVENTIVE MAINTENANCE**

A quality preventive maintenance program would include routine maintenance procedures, charts, wiring diagrams, and checklists that are current. These would indicate that the owner was in charge of his dam. Items to look for during maintenance of electrical systems are shown on the checklist. When items need to be corrected, it is best to make a list and give priorities to the tasks for accomplishment.

### 13.7-4 **ELECTRICAL CHECKLIST**

1. Check the fuses!
2. Open Circuit — is there a broken wire or defective switch?
3. Short Circuit — one wire touches another wire that it is not supposed to touch.
4. Grounded Circuit — one wire or more is grounded where it is not supposed to be.
5. Is moisture kept out of the system?
6. Is dust kept out of the system?
7. Is there evidence of corrosion?
8. Are there mineral deposits?
9. Are there kinks in the wire?
10. Is the conduit pipe bent or crimped?

11. Is support (telephone pole, brackets, anchorings) adequate?
12. Are there any fire hazards?
13. Are people safe from a shock or electrocution?
14. Is there a good dependable supply of power?
15. Will device operate when needed?
16. If you can't solve the problem call an electrician.

### 13.7-5 GENERATORS

Generators may be used for back-up when a power supply is cut off. Fuel availability, oil changes, battery checks and antifreeze checks are part of maintaining these items before they are needed for an emergency.

### 13.7-6 SUMMARY

Periodically, the electrical systems need to be:

Checked

Maintained in a clean, moisture-free and tight condition

Tested for emergencies

Evaluated for regular replacement

Repaired

Records should be kept noting the item, date, and what was done to the electrical device. The final questions that help guide good maintenance are:

Do people know how to operate the equipment? Will the piece of equipment operate when needed?

## 13.8 HYDRAULIC SYSTEM

### 13.8-1 INTRODUCTION

A hydraulic control system is used to open and close the valves or sliding gates of the outlet or intake works. A hydraulic system is especially desirable where the gate or valve requires great force to operate, or the gate or valve is located in an inconvenient place. The following is a schematic drawing of a typical hydraulic system:

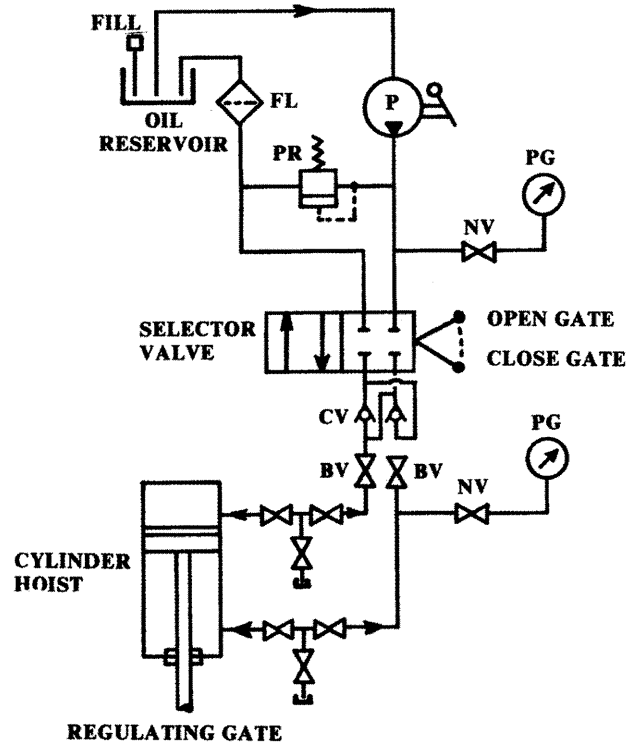

#### LEGEND

- BV BALL VALVE
- CV CHECK VALVE — PILOT OPERATED
- FL FILTER
- NV NEEDLE VALVE
- P PUMP, MANUAL
- PG PRESSURE GAUGE
- PR PRESSURE RELIEF VALVE

FIGURE 13.8-1 — SCHEMATIC HYDRAULIC OPERATING SYSTEM

The main component parts of a hydraulic system consist of hydraulic cylinders, hoses, pipelines, pumps (electric and/or hand powered), and hydraulic fluid reservoirs. Control, operating, and auxiliary components include control valves, safety (or overload) valves, pressure gauges, position indicators, etc.

A hydraulic system for gate operation is essentially similar to a hydraulic jack that is used to jack up cars. The main difference is that the hydraulic system usually has long hoses and pipelines to transmit hydraulic fluid to the gate-operating cylinders, and that there are gauges to indicate hydraulic pressure in the system.

### 13.8-2 ROUTINE INSPECTION AND MAINTENANCE

**Hydraulic cylinders:** Check for signs of leakage around actuating cylinders, at flanges, piston rod packings, etc. Leakage can be eliminated or reduced by tightening flange bolts, adjusting or replacing packings or gaskets, and/or cleaning and smoothing the rods that pass through the packing glands. Check for rusting or deformation of the rods. All new cylinders should be fabricated of corrosion resistant materials. The packing gland should be equipped with external wiper seals.

**Hoses and pipelines:** A check should be made for loose fittings, corrosion, mechanical damage, weak spots, inadequate support, or any unusual condition. A kinked hose should be straightened, and a bulging or leaking hose replaced. A kinked, bent or corroded pipe should be replaced. The replacement pipe should be of the same material as the original. Leakage of fluid from the hoses and pipelines is a commonly encountered problem. Look at the water surface near the lines for oil slicks, the presence of which would indicate leakage in the underwater portion of the lines. Build up a slight pressure in the system, with the gate closed, and check for any leakage, change in pressure, or gain or loss of fluid in the fluid reservoir.

**Regular maintenance:** Lubrication, inspection of hydraulic fluid, and fluid filter replacement should be performed at regular intervals as recommended by the manufacturer. The hydraulic fluid should be maintained at the correct level in the reservoir. If fluid color or viscosity has changed, or if rust, impure matter, or water is present, a specialist should be consulted to identify the exact cause of the problem. Remedial actions should be taken as soon as possible.

All controls should be clearly labeled. Operating instructions, piping diagrams, and the manufacturer's instruction book should be posted at a conspicuous and convenient spot. Clean up all oil spills immediately.

### 13.8-3 TEST OPERATION

The hydraulic system should be tested at least twice annually to ascertain that everything will function properly in case of an emergency. If the system is being used regularly to control flows, then a special test may not be necessary. During operation, the gate or valve should be tested for ability to go from fully closed to fully open position under full reservoir head and flow. Observe the performance of the hydraulic pump, control valve, safety valves, pressure gauges, etc. If there is a hand-powered or reserve pressure tank back-up system, this should also be tested. Pay special attention to the items on the following checklist.

1. Are hydraulic system pressures steady during the opening or closing of the gate?
2. Is pressure in the system too high, indicating that the gate or valve might be stuck?
3. Is there vibration or jerking, indicating possible lack of lubrication or misalignment of parts?
4. Does oil level stay within specified limits in the reservoir during operation?
5. Are there unusual noises during operation? What is the source or cause?
6. Does the motor or hydraulic pump overheat?

If there is a problem, consult the user's manual or an expert and take appropriate remedial actions at once.

### 13.8-4 MISCELLANEOUS

The hydraulic control system should be installed in a room or vault. Access to the room or vault should be controlled to prevent vandalism or unauthorized operation. The operator should always have the key to enter the control room. Make sure that the door cannot be jammed shut under any adverse situations such as a storm or after an earthquake. If there is no regular lighting, battery-powered lanterns or flashlights should be readily available for emergency operation at night. A reserve supply of the right type of hydraulic fluid should be stored in a suitable place in the control room or a place close to it.

### 14.1 INTRODUCTION

The objective in formulating an operating procedure or plan is to provide the greatest possible assurance of the safety of the dam and continuous operation of the reservoir.

An effective plan provides all the information and instruction needed to allow an inexperienced person to perform all actions required to operate the dam safely.

Among the items addressed are the operation of valves and headgates, periodic inspection of the dam, monitoring the dam's performance, recording and interpreting the results of the inspection and monitoring, and performance of all required maintenance.

By drawing up and using an operating procedure, the dam owner and/or shareholders can expect these benefits:

- Assuring the safety of the dam and continuous operation of the reservoir
- Avoiding the waste of stored water by having it under control at all times
- Minimizing the need for costly repairs
- Extending the useful life of the structure

Assembling the required information and writing the operating procedure is the responsibility of the dam owner. The information provided here is meant to act as a guide to assist the owner in preparing his operating plan. Additional assistance from an experienced consulting engineer may be helpful.

### 14.2 PUTTING THE PROCEDURE TOGETHER

14.2-1 **INFORMATION** — Maps, plans, and other sources should be reviewed for dimensions and descriptions that will provide a clear picture of the location, makeup, and function of each part of the dam. Especially important are:

1. Overall dimensions of the dam and spillway.
2. Outlet configuration and operation.
3. Drainage systems and outfall locations.
4. Location and detail of monitoring points.
5. Capacity tables for the reservoir.
6. Discharge tables for the outlet and spillway.
7. Location and capacity of inflow and outflow ditches.
8. Records of past inspections, monitoring, repairs, and operating problems.
9. Photographs of snow drifts which accumulate on and may saturate portions of the dam, taken annually and kept on file for comparison and reference.

If a detailed set of drawings for the dam does not exist, a plan and representative cross sections should be drawn up. To avoid confusion, these should be drawn to a convenient scale (e.g., 1 inch = 20 feet).

14.2-2 **OUTLET AND RESERVOIR OPERATING INSTRUCTIONS** — A clear step-by-step set of instructions for operating the outlet system should be drawn up. Proper sequence to be followed in opening and closing guard gates, gate usage for low and high flow, opening ranges where excessive vibration is experienced, and operating problems peculiar to a specific gate should be listed. For hydraulic and electrically actuated gates, a clear schematic diagram should be developed showing each component (including back-up equipment) and its place in the operating sequence.

Instructions concerning the general operation of the reservoir, including the regulation of inflow and outlet ditches, should be formulated. These will address maximum storage elevations to be observed in anticipation of spring run-off or winter and spring windstorms, maximum and/or minimum carry-over storage, maximum and/or minimum permissible outlet releases, operation of the outlet to limit or prevent excessive spillway flows, and periodic drainage of the reservoir to permit a thorough outlet or upstream slope inspection.

14.2-3 **INSPECTION** — Frequent periodic inspection is essential in efforts to assure the safety of the dam and to identify areas requiring maintenance before major problems develop. The operating plan should identify any areas requiring special or more frequent inspection. Using a standard reporting form will allow inspection findings to be assessed with the most coherence. Forms found in Chapter 4 may be useful. Instructions for the completion, retention, and filing of the inspection reports should be provided.

14.2-4 **MONITORING INSTRUCTIONS AND FORMS** — The benefits of monitoring the dam can only be achieved if the observations are recorded in an orderly way, then put into a form that will allow the data to be seen as a performance record. This will require plotting or charting some of the readings. See Chapter 12.

A map identifying each monitoring point for the dam is required. Each of these monitoring points plus any seepage or other areas needing special attention should be kept clear of obscuring growth and be permanently marked so they can be found during inspection.

Instructions on how to make and record each measurement or observation must be provided. If the owner's engineer is not going to plot or chart the data, instructions and forms should be developed to allow owners, operators, or maintenance personnel to do this work. An experienced consulting engineer may be of assistance in preparing the required formats.

Occasionally the State Engineer will request that the plotted or charted data be sent to the Dam Safety Branch for review and to become a part of the dam's records. When requested, provision should be made for duplicating and forwarding the information.

14.2-5 **MAINTENANCE INSTRUCTION** — Any special instructions for performing periodic maintenance should be given in detail. This will allow new personnel to understand the task and experienced personnel to make sure they have completed the work properly. All required maintenance work should be identified and listed. This listing may include:

1. Cleaning brush and trees.
2. Removing debris.
3. Regrading the crest and/or access roads.
4. Removing harmful rodents.
5. Cycling and lubricating gates.
6. Adding riprap when required.
7. Sealing joints in concrete facings.
8. Cleaning drain pipes and outfalls.
9. Maintaining protection for monitoring points.
10. Maintaining security for operating equipment.

14.2-6 **SCHEDULE** — Once the various required tasks have been identified, a schedule showing the frequency for each item needs to be drawn up.

Suggested minimum frequencies for various activities are:

**HIGH HAZARD DAMS** — Failure of the dam would cause extensive property damage and would probably cause the loss of human life.

Daily — Surveillance by the owner or caretaker.

Weekly — Monitoring of seepage.

Monthly — Thorough visual inspection. Gathering, immediately plotting, and interpreting observation well and piezometer data.

Annually — Reading horizontal and vertical control monuments (more frequently if necessary).

Routine maintenance as required.

Bi-Annually — Test operation of outlet and spillway mechanical components.

**MODERATE HAZARD DAMS** — Failure of the dam would cause extensive property damage but is not expected to cause loss of human life.

Weekly — Surveillance by the owner or caretaker. Monitoring of seepage.

Monthly — Thorough visual inspection when storage is in excess of one-half the maximum gage rod reading.

Gathering, plotting and interpreting observation well and piezometer data when storage is in excess of one-half the maximum gage rod reading.

Annually — Test operation of outlet and spillway mechanical components.

Bi-Annually — Reading of horizontal and vertical control monuments after a satisfactory performance record has been established for the dam.

Routine maintenance as required.

**LOW HAZARD DAMS** — Failure would cause little damage beyond the loss of the dam structure itself.

Monthly — Surveillance by the owner or caretaker.

Monitoring of seepage when storage is in excess of one-half the maximum gage rod reading.

Gathering, plotting, and interpreting observation well and piezometer data when storage is in excess of one-half the maximum gage rod reading.

Annually — Thorough visual inspection. (If the reservoir is full all year, visual inspection should be done quarterly.) Testing of the outlet.

Every Five Years — Reading of horizontal and vertical control monuments after a satisfactory performance record has been established.

Routine maintenance as required.

14.2-7 **RECORD** — As part of the operating plan, the data relating to the dam should be organized into a permanent continuous record. All ongoing repairs should be fully described and this information added to the record. This will help in assessing future changes especially when they are viewed by personnel unfamiliar with the dam.

14.2-8 **COMMUNICATION** — A list of the agencies involved in the administration of the dam and the names of the people currently representing those agencies should be included in the operating plan along with identification of each agency's involvement. This will help promote required communication and a cooperative relationship with those agencies.

---

### 14.3 ASSIGNING RESPONSIBILITY

After the operating procedure has been written, reviewed, and found acceptable, the owner needs to identify who will carry out the various duties. Copies of the completed plan should be distributed to and reviewed with each participant. Each member of the board of directors should also be familiar with the operating plan. This will aid them in exercising their responsibilities to the shareholder, especially in the area of funding routine maintenance and providing contingency funds for non-routine repair work.

### 14.4 SUMMARY

By conscientiously following a well-thought-out operating procedure the dam owner can expect:

- Maximum assurance of a safe dam.

- Maximum assurance of uninterrupted service for the dam and reservoir.

- Reduced maintenance costs.

- An extended useful life for the dam.



### 15.1 INTRODUCTION

**GOAL** — An emergency preparedness plan is a written procedure for reacting to emergency situations caused by the threat of a dam failure. The goals of the plan are:

1. To prevent loss of life.
2. To minimize property damage.

Keeping a dam from failing is the most assured way to prevent loss of life and property damage. Therefore, emphasis must be placed on saving the dam from failure.

**RESPONSIBILITY** — The dam owner is responsible for drafting the plan, providing copies to participants, coordinating emergency actions, and activating the plan immediately when a failure threatening situation is reported.

#### REQUIREMENT

**High Hazard Dams** — Sudden failure of the dam would cause the loss of life. In the interest of public safety the State Engineer has requested written plans for these dams. The plan includes evacuation of persons located in the dam breach flood plain.

**Moderate Hazard Dams** — Sudden failure of the dam would not cause loss of life but would cause extensive property damage. Since the owner of the dam is responsible for damages caused by the uncontrolled release of water from a dam failure, a written plan is recommended. This plan usually does not include evacuation.

**Low Hazard Dams** — Sudden failure would cause little loss other than the structure itself. A written plan is recommended to allow the best chance to save the dam and avoid costly reconstruction.

#### RESULT

By planning in advance for quick and prudent action and by devising an effective timely warning to downstream residents, the disastrous results of a dam failure can be avoided.

### 15.2 GENERAL INFORMATION

Addressing an emergency situation will require the cooperation of many persons and entities. The following list is provided to alert the owner to those that may be involved.

#### LOCAL PARTICIPANTS

The dam's owners, shareholders, and beneficiaries  
Officials of the nearby downstream cities and towns  
Local police, county sheriff  
Local fire departments  
County highway department personnel  
Local construction companies  
News media serving the area (i.e., radio, TV, newspapers)  
Nearby engineering firms  
Professional diving service  
Helicopter service  
Hospital and/or ambulance service

#### STATE AGENCIES

State Engineer's Office  
State Engineer  
Dam Safety Branch  
Local Water Commissioner  
Division Engineer  
Division of Disaster Emergency Services, Local Coordinator (D.O.D.E.S.)  
State Patrol  
Department of Highways  
Department of Health

#### FEDERAL AGENCIES

U.S. Forest Service  
Bureau of Reclamation  
National Park Service  
Soil Conservation Service  
U.S. Army Corps of Engineers  
Federal Bureau of Investigation  
Federal Energy Regulatory Commission  
United States Geological Survey  
Federal Emergency Management Agency

A directory of these and any other agencies involved should be established which lists the home phone, address, and office phone of the primary and secondary contacts for each, as well as a listing of the equipment and/or service they can provide and stating an estimate of their response time. This directory should be updated as needed. An example will be found in Section 15.7.

### 15.3 REPORTING INCIDENTS

**Dam incidents should be reported immediately by the person discovering the dangerous condition to the person responsible for executing the emergency plan (listed on the data sheet and in the EMERGENCY PLAN).**

Generally, the person who first discovers what appears to be a potentially hazardous condition at a dam site will have little or no background in dam design, construction, or safety. In order to be able to properly identify a potentially dangerous condition, it is necessary that dam tenders and others who visit the site regularly are familiar with all features of the dam and dam site. This is especially true for dams with a history of leakage, cracking, settlement, misalignment, and erosion from wave action. Also, it is necessary to have a knowledge of measurements of significant drain and seepage outflows to act as a basis for meaningful comparisons.

(When reporting a dam incident, remember that when locating problem areas, all directions, e.g., "left of" or "right from," are taken while facing downstream.)

Items that should be reported are:

1. Name of dam, lake, or reservoir, and river, stream, or tributary the dam is located on.
2. Location from highway or nearest town (U.S., state, or county road numbers); also section, township and range, and PM, if known.
3. Nature of the problem (e.g., excessive leakage, cracks, sand boils, slides, wet spots, etc.).

4. Location of problem area in terms of embankment height, (e.g., about 1/3 up from the toe) and location along the dam's crest (e.g., 100 feet to the right of the outlet or abutment) and whether on the upstream slope, crest, or downstream slope.
5. Extent of the problem area. This can be satisfactorily established by pacing.
6. Estimated quantity of unusual flows as well as whether the water is clear, cloudy, or muddy.
7. Water level in the reservoir below the dam's crest or below the spillway, or the gauge rod reading.
8. Is water level in reservoir rising or falling?
9. Name and how to contact person making report.
10. Did the situation appear to be worsening while being observed for this report?
11. Does the problem appear to be a containable problem at this time or is it an emergency situation?
12. What are current weather conditions at the site?
13. Anything else that seems important.

A reporting form will be found in Section 15.7.

This list should be periodically reviewed by owners' representatives who frequently visit the dam site. It will alert them to make all these observations before reporting the incident. An accurate report will allow an intelligent assessment of the situation and proper implementation of the plan.

#### 15.4 POTENTIAL PROBLEMS AND IMMEDIATE DEFENSIVE ACTIONS (To be taken before or while a detailed engineering assessment is made)

The general approach to each threatening situation as listed below should be reviewed and the actions implemented as soon as possible in each situation.

##### OVERTOPPING BY FLOOD WATERS

1. Fully open outlet to reduce overflows.
2. Place sandbags along the crest to increase freeboard and force more water through the spillway and outlet.
3. Provide erosion-resistant protection to the downstream slope by placing plastic sheets or other materials over eroding areas.
4. Divert flood waters around the reservoir basin, if possible.
5. Create additional spillway capacity by making a controlled breach in a low embankment or dike section where the foundation materials are erosion resistant.

##### LOSS OF FREEBOARD OR DAM CROSS SECTION DUE TO WAVE EROSION CAUSED BY HIGH WINDS

1. Lower water level to an elevation below the damaged area.
2. Immediately place additional riprap or sandbags in damaged areas to prevent further embankment erosion.

3. Restore freeboard with sandbags or earth and rockfill.
4. Continue close inspection of the damaged area until the storm is over.

##### SLIDES IN THE UPSTREAM OR DOWNSTREAM SLOPE OF THE EMBANKMENT

1. Lower water level at a rate and to an elevation which are judged to be safe under the slide condition. If the outlet is damaged or blocked then pumping, siphoning, or a controlled breach may be required.
2. Restore lost freeboard if required. This may entail placing sandbags or fill on top of the slide.
3. Stabilize slides on the downstream slope by weighing the toe area with additional soil material, rock, or gravel.

##### FLOWS THROUGH THE EMBANKMENT, FOUNDATION, OR ABUTMENTS WHICH ERODE THE MANMADE OR NATURAL MATERIALS CONTAINING THE RESERVOIR

1. If the entrance area of the leak in the reservoir basin can be found, try to plug it off with whatever materials are available such as hay bales, manure, mattresses, bentonite, plastic, etc.
2. Lower the water level until the flows decrease to a non-erosive velocity or until the flow stops.
3. Place a protective sand and gravel filter over the exit area to hold materials in place.
4. Continue lowering the water level until an elevation judged to be safe is reached.
5. Continue operating at a reduced level until repairs can be made.

##### FAILURE OF APPURTENANT STRUCTURES SUCH AS THE OUTLET OR SPILLWAY

1. Implement temporary measures to protect the damaged structure, such as closing the outlet or providing temporary protection for the damaged spillway area.
2. Experienced professional divers may be able to quickly assess the problem and possibly implement repair.
3. Lower the water level to an elevation judged to be safe. If the outlet is inoperable, then pumping, siphoning, or a controlled breach may be required.

##### MASS MOVEMENT OF THE DAM ON ITS FOUNDATION; i.e., SPREADING OR MASS SLIDING FAILURE

1. Immediately lower water level until excessive movement stops.
2. Continue lowering water until a level judged to be safe is reached.
3. Continue operating at a reduced level until repairs can be made.

### HIGH LEVEL SATURATION OF THE ENTIRE EMBANKMENT CROSS SECTION DUE TO EXCESSIVE SEEPAGE

1. Lower the water to a level which is judged to be safe.
2. Continue frequent monitoring for signs of slides, cracking, or concentrated seepage.
3. Continue operation at a reduced level until repairs can be made.

### SPILLWAY BACKCUTTING THREATENS RESERVOIR EVACUATION

1. Reduce flows over the spillway by fully opening the outlet.
2. Provide temporary protection at the eroding surface by placing sandbags or riprap material.
3. When inflows subside, lower water level to a level judged to be safe.
4. Continue operating at a low water level in order to prevent spillway flows.

### EXCESSIVE SETTLEMENT OF THE EMBANKMENT

1. Lower water level by releases through the outlet or by pumping, siphoning, or a controlled breach.
2. If necessary, restore freeboard, preferably by placing sandbags.
3. Continue lowering water to a level judged to be safe.
4. Continue operating at a reduced level until repairs can be made.

### LOSS OF ABUTMENT SUPPORT OR EXTENSIVE CRACKING IN CONCRETE DAMS WHICH COULD CAUSE SUDDEN FAILURE

1. Lower the water level by releases through the outlet.
2. Attempt to block water movement through the dam by placing plastic sheets etc., on the upstream face.
3. Prepare to notify and evacuate downstream residents.
4. Continue lowering water to a level judged to be safe.

## 15.5 HELPFUL SUGGESTIONS

Following are suggestions for making a controlled breach, sandbagging, and plastic sheet placement:

### CONTROLLED BREACH

One method of making a controlled breach is to construct a small coffer dam upstream from the breach area. Then excavate the breach through the embankment and place an appropriately sized pipe through the embankment and backfill around the pipe and re-establish to embankment freeboard. The coffer dam can then be removed and water released through the newly installed pipe.

### SANDBAGGING

When placing sandbags in high velocity flow water, it is difficult to keep the bags in place. In order to control water in this situation it is advisable to:

1. Make sure the bags are securely tied so the material does not wash out of them.
2. Begin placement near the shore or in a quiet area and work toward the higher velocity flow areas.

### PLASTIC SHEET PLACEMENT

Plastic sheets normally used in construction have been employed successfully to resist erosion of a dam's downstream slope or spillway channel during storm flows. The top end of the sheet must be securely anchored in a nearly horizontal area such as the crest area, where velocities are low. Closely spaced sandbags or rocks will anchor the sheet and minimize flow under the sheet. This protection should be extended beyond the dam's toe or the eroding area in the spillway by overlapping with the upper sheet over the lower one and anchoring successive sheets.

## 15.6 ADDITIONAL CONSIDERATIONS

### WARNING TO DOWNSTREAM RESIDENTS

Generally, in more densely populated areas, warning to downstream residents will be carried out through the county sheriff or town or city police department. This warning will be initiated by the person executing the emergency plan.

In rural locations the warning may have to be given by phone or direct contact with the nearest downstream residents. Where phone communication is not available, the person observing the dangerous condition may have to provide the warning to the nearest downstream residents, campers, etc. A listing of the nearest downstream residents should be kept by the person responsible for implementing the plan and an additional copy kept at the dam site.

### RESPONSE TIME

Many of the dams within the state are located in areas where access is very time consuming. In order to assess the actual response to an incident at all dams properly, it is important to establish a realistic estimate of the time that will be required for the various participants in the plan to reach the dam site. This is especially true for the engineers who will be responsible for an accurate evaluation of the situation and recommending on-site remedial actions and subsequent repairs.

### FLOOD ARRIVAL TIME

An estimate of the time that it will take for the flood caused by a dam failure to reach the nearest dwelling and downstream town should be made. This will aid in scheduling the sequence of warning and defensive actions. Local water commissioners or the Division Engineer may be of assistance in making this estimate.

### SITUATIONS TO BE ADDRESSED

Several situations should be anticipated and the required notification or actions specified. In general, they are:

- A. Failure pending — structure may be saved with immediate remedial action.
- B. Failure imminent — structure may be saved with immediate remedial action.
- C. Failure in progress — no chance to save the structure.
- D. Flooding expected or in progress upstream from the dam site.
- E. Any other conditions peculiar to this dam.

The required notification and actions for each situation should be thought out and planned in advance.

### NOTIFICATION TO THE DIVISION ENGINEER AND LOCAL WATER COMMISSIONER

When unusual flow due to the controlled or uncontrolled release of water is anticipated, the Division Engineer and/or Water Commissioner should be notified as required in CRS 1973 as amended, 37-87-103. In addition to allowing for minimizing flooding and providing protection of downstream water control structures, these administrative personnel may be able to find a way to regain control of the released water for future use by the affected community.

### FLOODED AREA MAPS

Where the floodplain downstream from a large capacity reservoir is heavily populated, it is recommended that reasonably accurate floodplain maps be made which will show the limits of flow for full spillway discharge and the limits of flooding for failure of the structure when filled to the spillway crest without storm inflow. These will be very helpful in identifying the actual areas where flooding is anticipated and where evacuation is required. Local flood control districts may provide assistance in the preparation of these maps.

### HELPFUL ITEMS

Items that should be kept at the dam site, or at a home, cabin, or storage facility nearby are: a list of the nearest downstream residents affected by flooding and the required method for warning them; a set of drawings that show the basic dimensions and typical cross sections of the dam; a table showing spillway discharge capacity and volume of surcharge storage for each foot of water above the spillway crest (this will be useful in predicting the magnitude of flows that will be experienced downstream); and a copy of recent leakage quantities or other pertinent monitoring data.

Additional items that are recommended at the dam site are:

A high intensity light source to facilitate night inspection. A spotlight with a minimum of 200,000 candlepower with an appropriate battery-pack would be good for this.

An annual log of repairs or major maintenance.

Photographs of snow drifts which accumulate on and may saturate portions of the dam should be taken annually and a file kept for comparison and reference.

An identification plate stating the dam name and name of the owner should be displayed at the site. As an example, this plate could be securely fastened to the outlet control works.

### 15.7 SAMPLE FORMS

In order to assist the owner in preparing an emergency plan, a number of forms are presented.

**DATA SHEET** — Provides basic information about the dam, reservoir, and downstream hazard, including the nearest downstream residents. Each person participating in the plan should be familiar with this information.

**REPORT FORM** — This is for the use of persons implementing the plan who did not see the dangerous condition that is threatening the dam. When the form is filled out by the person executing the plan, it will help assure that each participant gets the same information about the situation.

**EMERGENCY PLAN** — The emergency plan provides an outline of the help various entities will provide along with their arrival times to the dam site. This is the heart of the Emergency Preparedness Plan and each person involved in the plan should have a copy and be familiar with its contents.

**DIRECTORY** — The directory allows quick reference for the contacts that must be made in reviewing, activating, and updating the plan. The directory must always be up to date. The person responsible for drafting the plan is usually responsible for keeping it current.

### DATA SHEET

NAME OF DAM \_\_\_\_\_

NAME OF DAM OWNER \_\_\_\_\_

**\*OWNER'S REPRESENTATIVE RESPONSIBLE FOR EXECUTING THE EMERGENCY PLAN**

Name	Position	Contact at Phone
#1. _____	_____	_____
#2. _____	_____	_____

PERSON RESPONSIBLE FOR DRAFTING AND UPDATING THIS PLAN \_\_\_\_\_

DAM LOCATION: \_\_\_\_\_ Sec. \_\_\_\_\_ Township. \_\_\_\_\_ Rng. \_\_\_\_\_ PM \_\_\_\_\_

RIVER OR STREAM \_\_\_\_\_ COUNTY \_\_\_\_\_

FOREST OR OTHER \_\_\_\_\_

NEAREST TOWN IN FLOOD PLAIN \_\_\_\_\_

ESTIMATED TIME FOR FLOOD TO REACH NEAREST TOWN \_\_\_\_\_ HR

ESTIMATED TIME FOR FLOOD TO REACH NEAREST HOME \_\_\_\_\_ HR

DIRECTIONS FROM TOWN TO DAM \_\_\_\_\_

DAM HEIGHT \_\_\_\_\_ Ft., CAPACITY \_\_\_\_\_ A.F.

SURFACE AREA \_\_\_\_\_ A.C., HAZARD RATING \_\_\_\_\_

CREST LENGTH \_\_\_\_\_ Ft., CREST WIDTH \_\_\_\_\_ Ft.

MAX. OUTLET CAPACITY \_\_\_\_\_

**SPILLWAY CAPACITY FOR EACH FOOT OF DEPTH**

Depth	Surcharge Storage	Service Spillway Capacity	Emergency Spillway Capacity
1 ft.	_____ AF	_____ CFS	_____ CFS
2 ft.	_____ AF	_____ CFS	_____ CFS
3 ft.	_____ AF	_____ CFS	_____ CFS
4 ft.	_____ AF	_____ CFS	_____ CFS
5 ft.	_____ AF	_____ CFS	_____ CFS
6 ft.	_____ AF	_____ CFS	_____ CFS

WHERE DRAWINGS AND DAMSITE EQUIPMENT ARE KEPT \_\_\_\_\_

**PERSONS DOWNSTREAM FIRST AFFECTED BY FLOOD WATERS**

**NAME**

**ADDRESS**

**PHONE**

**NO. OF RESIDENTS**

1. \_\_\_\_\_

\_\_\_\_\_

\_\_\_\_\_

\_\_\_\_\_

2. \_\_\_\_\_

\_\_\_\_\_

\_\_\_\_\_

3. \_\_\_\_\_

\_\_\_\_\_

\_\_\_\_\_

\_\_\_\_\_

4. \_\_\_\_\_

\_\_\_\_\_

\_\_\_\_\_

\_\_\_\_\_

5. \_\_\_\_\_

\_\_\_\_\_

\_\_\_\_\_

\_\_\_\_\_

6. \_\_\_\_\_

\_\_\_\_\_

\_\_\_\_\_

\_\_\_\_\_

\_\_\_\_\_

## DAM INCIDENT REPORT FORM

DATE \_\_\_\_\_ TIME \_\_\_\_\_

NAME OF DAM \_\_\_\_\_

STREAM NAME \_\_\_\_\_

LOCATION \_\_\_\_\_

COUNTY \_\_\_\_\_

NATURE OF PROBLEM \_\_\_\_\_

\_\_\_\_\_

LOCATION OF PROBLEM AREA (LOOKING DOWNSTREAM) \_\_\_\_\_

\_\_\_\_\_

EXTENT OF PROBLEM AREA (MEASURE, PACE, OR ESTIMATE) \_\_\_\_\_

\_\_\_\_\_

ESTIMATED QUANTITY AND COLOR OR UNUSUAL FLOW \_\_\_\_\_

\_\_\_\_\_

WATER LEVEL IN RESERVOIR \_\_\_\_\_

NAME OF PERSON WHO OBSERVED CONDITION \_\_\_\_\_

PHONE OR HOW TO CONTACT OBSERVER \_\_\_\_\_

WAS SITUATION WORSENING? \_\_\_\_\_

DOES IT APPEAR TO BE AN EMERGENCY? \_\_\_\_\_

WHAT ARE CURRENT WEATHER CONDITIONS AT THE SITE? \_\_\_\_\_

\_\_\_\_\_

OTHER \_\_\_\_\_

\_\_\_\_\_

\_\_\_\_\_

\_\_\_\_\_

\_\_\_\_\_

\_\_\_\_\_

\_\_\_\_\_

\_\_\_\_\_

## EMERGENCY PLAN

**ESTIMATED TRAVEL  
TIME TO SITE**

**1. Arrange for immediate inspection of the site:**

Person responsible \_\_\_\_\_

Person familiar with site to make inspection \_\_\_\_\_ hr.

Engineer to make inspection \_\_\_\_\_ hr.

**2. Establish communication with participants:**

Person responsible \_\_\_\_\_

Alternate \_\_\_\_\_

**3. Notify State Engineer's Office:**

Water Commissioner \_\_\_\_\_ hr.  
To make provision for increased flow downstream

Dam Safety Branch \_\_\_\_\_ hr.  
To inspect dam and recommend or concur with remedial action

**4. Provide required equipment and materials:**

Owner can provide \_\_\_\_\_  
\_\_\_\_\_ hr.

Contractor "A" can provide \_\_\_\_\_  
\_\_\_\_\_ hr.

Contractor "B" can provide \_\_\_\_\_  
\_\_\_\_\_ hr.

Highway Department can provide \_\_\_\_\_  
\_\_\_\_\_ hr.

D.O.D.E.S. can provide \_\_\_\_\_  
\_\_\_\_\_ hr.

Contractor "C" can provide \_\_\_\_\_  
\_\_\_\_\_ hr.



**EMERGENCY PLAN CONT.**

5. Provide required manpower:

Owner can provide \_\_\_\_\_ hr.  
College "A" can provide \_\_\_\_\_ hr.  
U.S. Military can provide \_\_\_\_\_ hr.  
Radio appeal can provide \_\_\_\_\_ hr.

6. Implement warning and/or evacuation:

Owner will \_\_\_\_\_ hr.  
D.O.D.E.S. will \_\_\_\_\_ hr.  
\_\_\_\_\_  
County Sheriff will \_\_\_\_\_ hr.  
\_\_\_\_\_  
State Patrol will \_\_\_\_\_ hr.  
\_\_\_\_\_  
Fire Department will \_\_\_\_\_ hr.  
\_\_\_\_\_

7. Medical or other assistance:

\_\_\_\_\_ will provide \_\_\_\_\_ hr.

8. Helicopter Service:

\_\_\_\_\_ will provide \_\_\_\_\_ hr.

9. Engineering firm can provide \_\_\_\_\_

\_\_\_\_\_ hr.

10. Report on actions taken:

Person Responsible \_\_\_\_\_  
\_\_\_\_\_ hr.

# DIRECTORY

## OWNERS REPRESENTATIVES RESPONSIBLE FOR PLANNED ACTION & CONTACT LOCATION

Name	Position	Address	Phone
1. _____			
2. _____			
3. _____			
4. _____			
5. _____			

### CITY OF

Name	Position	Address	Phone
1. _____			
2. _____			

### COUNTY SHERIFF

Name	Position	Address	Phone
1. _____			
2. _____			

### OFFICE OF STATE ENGINEER

Name	Position	Address	Phone
Alan Pearson	Chief, Dam Safety	1313 Sherman, #818 Denver, CO 80203	866-3581 (O) 773-0932 (H)
John Schurer	Dam Safety Branch	1313 Sherman, #818 Denver, CO 80203	866-3581 (O) 722-1964 (H)

Field Engineer

Division Engineer

Water Commissioner

### D.O.D.E.S.

Name	Position	Address	Phone
1. _____			
2. _____			

**AMBULANCE SERVICE**

<b>Name</b>	<b>Position</b>	<b>Address</b>	<b>Phone</b>
1. _____			
2. _____			

**HELICOPTER SERVICE**

<b>Name</b>	<b>Position</b>	<b>Address</b>	<b>Phone</b>
1. _____			
2. _____			

**DIVING SERVICE**

<b>Name</b>	<b>Position</b>	<b>Address</b>	<b>Phone</b>
1. _____			
2. _____			

**OTHER**

<b>Name</b>	<b>Position</b>	<b>Address</b>	<b>Phone</b>
1. _____			
2. _____			

**PERSONS DOWNSTREAM FIRST AFFECTED BY FLOOD WATERS**

<b>Name</b>	<b>Address</b>	<b>Phone</b>	<b>No. of Residents</b>
1. _____			
_____			
2. _____			
_____			
3. _____			
_____			
4. _____			
_____			
5. _____			
_____			
6. _____			
_____			

# CHAPTER 16

## COLORADO LAWS RELATED TO DAMS

### 16.1 INTRODUCTION

Statutes and regulations pertaining to reservoirs, dams, and the liabilities associated with them are presented in this chapter.

The laws:

1. Give the right to store any of the unappropriated waters of the state.
2. Hold the owners of dams liable for all damages caused by leakage, overflow, or floods caused by failure of their dams (employees, shareholders, and directors of boards are personally exempt if a sufficient insurance policy is provided covering not less than \$50,000 for each occurrence and an aggregate amount not less than \$1 million).
3. Require that plans and specifications be prepared by a registered professional engineer in Colorado and be approved by the State Engineer and filed in his office preceding construction of any new dam, or the enlargement, alteration, or major repair of an existing dam 10 feet in height from the bottom of the channel to the bottom of the spillway, or higher.
4. Require the State Engineer to determine the safe storage capacity of the reservoirs on an annual basis, and when requested by citizens.

Small dams that are used primarily for erosion control and/or livestock watering are exempt from filing engineered plans and specifications, but they must have a permit which is granted by the State Engineer and they must be constructed in accordance with the State Engineer's standard specifications. The maximum size for these dams is 15 feet from the bottom of the channel to the bottom of the spillway and a capacity of 10 acre-feet. The dams will be permitted only on normally dry streams, and they cannot be used for irrigation purposes. An Erosion Control Dam must have a minimum size uncontrolled outlet of 12 inches located at the 2-acre-foot level, or lower; and livestock water "tanks" may require a low level controlled outlet as determined by the Division Engineer. Application forms are available for these dams from the State Engineer or Division Engineers, and they must be submitted to the Division Engineer or their Water Commissioners for preliminary approval.

### 16.2 APPROVAL OF PLANS

The construction plans for dams must be prepared in accordance with the State Engineer's regulations. Copies of the regulations are available at no charge to the public. They state the requirements of the State Engineer for preparation and filing of the plans and specifications. The objective is to assure that the designs are safe and that the structures, when completed, will not deteriorate abnormally and jeopardize the safety of the public. The design engineer should contact the Design Review Unit, in the State Engineer's Office early in the planning stages to learn the requirements. A comprehensive discussion of design review is too lengthy for this manual.

### 16.3 CONSULTING ENGINEERS

The State Engineer requires that the work of construction be monitored by a professional engineer (preferably the one who designed the plans) on a continuous basis, who can certify to the completion of the work in accordance with the approved plans and specifications. The engineer also must periodically furnish the State Engineer with data and reports as requested and furnish the AS-BUILT plans and specifications for filing. Most importantly, he must make sure that the plans and specifications, as approved, are compatible with the site conditions and modify the design as required due to changed conditions. Modifications must also be approved by the State Engineer before construction. The consulting engineer can also perform the contract administration work with the contractors for the owner and provide analysis and evaluation of the contractor's proposals for conduct of the work, as well as the quality control work specified.

### 16.4 SAFETY EVALUATION OF EXISTING DAMS AND CONSTRUCTION INSPECTION

The State Engineer's Office conducts periodic inspections of the several dams throughout the state in order to evaluate the safe storage level, assure that the owners are operating and maintaining their dams in a safe manner, and identify any conditions that could jeopardize the safety of the dam. The concerted efforts of the owners, using the principles of this manual, and the State Engineers' evaluations will reduce the chance of failure of existing dams.

The State Engineer also makes evaluations of the safety of any dam of which the public complains and recommends the safe operating level necessary to prevent the likelihood of failure, or breaching of the dam, as required.

### 16.5 COLORADO STATUTES RELATING TO DAMS RESERVOIRS

C.R.S. 73, 37-87-101

#### Right to Store Waters

Persons desiring to construct and maintain reservoirs for the purpose of storing water have the right to store therein any of the unappropriated waters of the state not thereafter needed for immediate use for domestic or irrigating purposes, and to construct and maintain ditches for carrying such waters to and from such reservoirs, and to condemn lands required for the construction and maintenance of such reservoirs and ditches in the same manner as now provided by law; except that after April 18, 1935, the appropriation of water for any reservoirs constructed when decreed, shall be superior to an appropriation of water for direct application claiming a date of priority subsequent in time to that of such reservoirs.

2. Underground aquifers are not reservoirs within the meaning of this section except to the extent such aquifers are filled by other than natural means with water to which the person filling such aquifer has a conditional or decreed right.

C.R.S. 73, 37-87-102 **Owner of Reservoir May Conduct Water Into Natural Streams.**

The owners of any reservoir may conduct the waters legally stored therein into and along any of the natural streams of the state, but not so as to raise the waters thereof above ordinary high watermark, and may take the same out again at any point desired with due regard to the prior or subsequent rights of others to other waters in said natural streams. Due allowance shall be made for evaporation and other losses from natural causes for the protection of all rights to the waters flowing in said streams, such losses to be determined by the state engineer.

C.R.S. 73, 37-87-103 **Notice of Release of Stored Waters.**

The owners of reservoirs who avail themselves of the provisions of this section and section 37-87-102 shall give reasonable prior notice to the irrigation division engineer of the irrigation division in which the reservoir is located or to the chief administrative water official of such irrigation division, of the date on which they desire to release stored waters into any natural streams, together with the quantity thereof in cubic feet per second of time, the length of period to be covered by such releases, and the name of the ditch, canal, pipeline, or reservoir to which the water so released from storage is to be delivered, to the end that the water officials in responsible charge of any stream into which such stored water is released shall have ample time in which to make the necessary observations, measurements of flow and storage and records thereof, and to provide for a proper patrol of the said stream, for the protection of the reservoir owner and also all other appropriators along the stream whose interests might be affected as a result of such reservoir release. Such notice may be given to the division engineer when the reservoir from which the water is to be released and the point where the water is to be taken from the stream or again stored are in the same water district.

C.R.S. 73, 37-87-104 **Liability of Owners for Damage**

1. Except as provided in subsection (2) of this section, the owner of a reservoir shall be liable for all damages arising from leakage or overflow of the waters therefrom or floods caused by the breaking of the embankments of such reservoir.
2. No employee, shareholder, or member of a board of directors of an owner of a reservoir shall be liable for any damage arising from leakage or overflow of the waters from such reservoir or for any damage arising from floods caused by breaking of the embankments of such reservoir if a valid liability insurance policy has been purchased by the owner of the reservoir and is in effect at the time such damage occurs. Such insurance policy shall insure against such damages and provide coverage in an amount of not less than fifty thousand dollars for each claim and in an aggregate amount of not less than one million dollars for all claims which arise out of any one incident. The policy may provide that it does not apply to any act or omission of an employee, shareholder, or member of a board of directors of an owner, which act or omission is dishonest, fraudulent, malicious, or criminal. The policy may also contain other reasonable provisions with respect to policy periods, territory, claims, conditions, and other matters common to such policies of insurance. The limitation of liability pursuant to this subsection (2) shall not apply to any criminal, fraudulent, or malicious act by a member of the board of directors of the owner, a shareholder of the owner, or an employee of such owner nor shall it apply to any ultra vires act of the owner or of a member of the board of directors, a shareholder, or an employee of such owner. The provisions of this subsection (2) shall not be deemed to impose any liability upon a member of the board of directors, a shareholder, or an employee of the owner of a reservoir beyond that established by other principles or provisions of law.
3. As used in this section, the word "owner" does not include public entities or public employees as defined in the "Colorado Governmental Immunity Act," article 10 of title 24, C.R.S. 1973.

C.R.S. 73, 37-87-105

**Approval of Plans for Reservoir**

No reservoir of a capacity of more than one thousand acre-feet, or having a dam or embankment in excess of ten feet in vertical height, from the bottom of the channel to the bottom of the spillway, or having a surface area at high waterline in excess of twenty acres shall be constructed in this state unless the plans and specifications for the same have first been approved by the state engineer and filed in his office. In making his determination, the state engineer shall be guided by criteria related to the probability that precipitation will be exceeded once in five hundred years. The state engineer shall act as consulting engineer during the construction thereof and shall have authority to require the material used and the work of construction to be done to his satisfaction. No work shall be deemed complete until the state engineer furnishes to the owners of such structures a written statement of the work of construction and the full completion thereof, together with his acceptance of the same, which statement shall specify the dimensions of such dam and capacity of such reservoir.

C.R.S. 73, 37-87-106

**Cost of Inspection and Supervision**

The owners of such reservoirs shall pay to the state engineer his actual expenses incurred in making personal inspection, including expenses for any person appointed by him attend to such supervision, not to exceed one hundred twenty-five dollars per day for each day necessarily employed for such purposes.

C.R.S. 73, 37-87-107

**Amount of Water To Be Stored**

The state engineer shall annually determine the amount of water which is safe to impound in the several reservoirs within this state, and it is unlawful for the owners of any reservoir to store in said reservoir water in excess of the amount so determined by the state engineer to be safe.

C.R.S. 73, 37-87-108

**Withdrawal of Excess Water.**

In the event of the owners of any such reservoir impounding water therein to a depth greater than that determined by the state engineer to be safe, it is the duty of the division engineer of the district wherein such reservoir is located to forthwith proceed to withdraw from said reservoir so much of the water as shall be in

excess of the amount so determined by the state engineer to be safe, and shall close the inlets to the same to prevent said reservoir from being refilled to an amount beyond what said state engineer has designated as being safe. In the event of the owners of said reservoir, or any other persons, interfering with the division engineer in the discharge of said duty, the said division engineer shall call to his aid such persons as he deems necessary, and employ such force as the circumstances demand to enable him to comply with the requirements of this section.

C.R.S. 73, 37-87-109

**Complaint That Reservoir Is Unsafe**

Upon complaint being made to the state engineer by one or more persons residing or having property in such a location that their homes or property would be in danger of destruction or damage in the event of a flood occurring on account of the breaking of the embankment of any reservoir within the state, that said reservoir is in an unsafe condition, or that it is being filled with water to such an extent as to render it unsafe, it is the duty of the state engineer to forthwith examine said reservoir and determine the amount of water it is safe to impound therein. If, upon such examination, the state engineer finds that said reservoir is unsafe, it is his duty to immediately cause said water to be drawn from said reservoir to such an extent as will, in his judgment, render the same safe. If water is then flowing into said reservoir, he shall cause it to be discontinued.

C.R.S. 73, 37-87-110

**Engineer May Use Force.**

The state engineer is authorized to use such force as is necessary to perform the duties required of him in section 37-87-109, and to have and exercise all of the powers conferred upon the division engineer by section 37-87-108. If, after any such reservoirs have been examined by said state engineer, the owners thereof, or any other person, fills or attempts to fill them, or any of them, to a point in excess of the amount the state engineer has determined to be safe, then it is the duty of the division engineer of the district wherein such reservoir is located to proceed as directed by section 37-87-108.

- C.R.S. 73, 37-87-111 Expense of Examination**  
The person calling upon the state engineer to perform the duty required of him by section 37-87-109 shall pay him in advance when requested or invoiced expenses, as provided in section 37-87-106, and mileage at the rate of ten cents per mile for each mile actually and necessarily traveled in going to and from said reservoir, and should the state engineer find upon examination that such reservoir is in an unsafe condition, the owners thereof shall be liable for all expenses incurred in such examination.
- C.R.S. 73, 37-87-112 Appeal From Decision of Engineer.**  
In the event of either party being dissatisfied with the decision of the state engineer, he may take an appeal to the district court of the county wherein said reservoir is located, and said court shall hear and determine the matter summarily at the earliest practicable time without written pleadings or the aid of a jury, subject to the right of either party to take an appeal as in other civil cases; except that the judgment of the state engineer shall control until final determination of the cause.
- C.R.S. 73, 37-87-113 Breakage of Reservoir — Damages**  
None of the provisions of sections 37-87-105 to 37-87-114 shall be construed as relieving the owners of any such reservoir from the payment of such damages as may be caused by the breaking of the embankments thereof, but in the event of any such reservoir overflowing, or the embankments, dams, or outlets breaking or washing out, the owners thereof shall be liable for all damage occasioned thereby.
- C.R.S. 73, 37-87-114 Penalty — Disposition of Fines.**  
Any reservoir company failing or refusing, after ten days' notice in writing has been given, to obey the directions of the state engineer as to the construction or filling of any reservoir shall be subject to a fine of not less than two hundred dollars for each offense, and each day's continuance after time of notice has expired shall be considered a separate offense. Such fines shall be recovered by civil action in the name of the people, by the district attorney, upon the complaint of the state engineer, in the county where the injury complained
- of occurred. The proceeds of all fines, after payment of costs and charges of the proceedings, shall be paid into the county treasury for the use of the general fund of the county.
- C.R.S. 73, 37-87-115 Damages.**  
Neither the state engineer nor any member of his staff or any person appointed by him shall be liable in damages for any act done by him in pursuance of the provisions of this article.
- C.R.S. 73, 37-87-116 Tax Reduction Where Reservoirs Located.**  
After April 8, 1937, anyone owning land in the state of Colorado not within the corporate limits of any city or town, who, by the construction of a dam across any watercourse, the channel of which is normally dry, as determined by the state engineer, and thereby forms upon his own land a reservoir for the collection and storage of unappropriated surface water, and who maintains such reservoir and dam in proper condition to safely impound water therein, or who donates to the state of Colorado or any of its agencies a tract of land on which it is feasible to construct and maintain one or more such storage reservoirs, as may be determined by the state engineer, shall be entitled to a reduction for general taxes in the valuation for assessment of the piece of land upon which such reservoir is located of forty dollars for each acre-foot of storage capacity provided by such reservoir; but the total amount of such reduction in the valuation for assessment shall not exceed twenty-five percent of the valuation for assessment of the contiguous acreage owned by such landowner, and upon which such reservoir is located. No reduction in the valuation for assessment shall be granted in cases wherein the storage is less than one and one-half acre-feet total capacity shown, and the total acreage so affected shall not exceed one hundred sixty acres. Nothing in sections 37-87-116 to 37-87-121 shall be construed as adversely affecting any presently vested water right, or valid appropriation of water.

C.R.S. 73, 37-87-117

**Landowner to Submit Plans.**

If any such dam has a maximum height of ten feet or less, or will create a reservoir having a surface area of twenty acres or less, or a capacity of sixty-five acre-feet or less, the landowner desiring to take advantage of sections 37-87-116 to 37-87-121 shall first submit to the state engineer sufficient engineering data, in the way of maps and plans, to show the location, type, and dimensions of the proposed dam, reservoir, and spillway and character of the foundation, and of the materials available for construction purposes. The state engineer has authority to pass upon the adequacy of such data and plans for such proposed dam, and to require that the work of construction be carried out and completed to his entire satisfaction. In making his determination, the state engineer shall be guided by criteria related to the probability that precipitation will be exceeded once in five hundred years.

C.R.S. 73, 37-87-118

**State Engineer's Authority Over Construction.**

The provisions of sections 37-87-116 to 37-87-121 shall not in any way, manner, or degree exempt the sponsor of any proposed, or the owner of any existing, dam in this state from the provisions of law which now require the approval by the state engineer of plans and specifications for all dams having a maximum height in excess of ten feet or which will create a reservoir with a surface in excess of twenty acres, nor from compliance with the present or any future authority of the state engineer over the construction, supervision, and administration of such dams.

C.R.S. 73, 37-87-119

**Completion of Dam.**

Upon the completion of any dam by a landowner, under the provisions of sections 37-87-116 to 37-87-121 relating to a reduction in the valuation for assessment of his land, the state engineer, under whose supervision such dam has been constructed, may so certify to the board of county commissioners of the county in which such dam is located, which certificate shall show the type of dam, maximum height and length thereof, width of spillway, and depth of the bottom of spillway below crest of dam, general dimensions and side slopes of the dam, diameter and character of outlet conduit, maximum area of reservoir

surface, capacity of reservoir in acre-feet, and approximate area of the drainage basin above the reservoir. The certificate shall also show the location of the reservoir described in terms of each quarter quarter section of land involved, or in terms of a metes and bounds survey of the proposed high waterline, the date of completion of the dam, and the name and address of the owner. The provisions of sections 37-87-116 to 37-87-121 shall not relieve the owner of such a reservoir of the obligation to install in any such dam a conduit of sufficient capacity to pass all the normal streamflow, for the satisfaction of the owners of water rights on the stream or streams below such reservoir.

C.R.S. 73, 37-87-120

**Reduction In Valuation For Assessment.**

Upon receipt of such certifications from the state engineer, the county board of equalization shall thereupon make such reduction in the valuation for assessment of the land on which any such reservoir is located as the owner of such land may be entitled to receive under the provisions of section 37-87-116. Each year, at the time of making his annual assessment, the assessor shall first ascertain whether the dam is being maintained in a safe condition and for the purpose of impounding water. In the event that the assessor reports that any such dam is not being maintained in a safe condition and for the impounding of water, that fact shall be reported to the board of county commissioners, and the reduction in the valuation for assessment shall not be allowed so long as such dam is not maintained for such purpose.

C.R.S. 73, 37-87-121

**Application to Existing Dams.**

The provisions of sections 37-87-116 to 37-87-120 shall extend to and include all dams constructed before April 8, 1937, in this state on watercourses which normally are dry, and which have been approved by the state engineer in accordance with sections 37-87-116 to 37-87-120.

C.R.S. 73, 37-87-122

**Erosion Control Dams**

- i. The provisions of sections 37-87-101 to 37-87-108 and 37-87-116 to 37-87-121 shall not apply to erosion control dams of the character defined in this section, unless such dams also come within the specification requirements of said sections.



2. Erosion control dams for reservoirs may be constructed on watercourses, the channels of which have been determined by the state engineer to be normally dry, having a vertical height not exceeding fifteen feet from the bottom of the channel to the bottom of the spillway, and having a capacity not exceeding ten acre-feet at the emergency spillway level, upon approval of an application for such erosion control dam by the state engineer. When such reservoirs are to be constructed with such height exceeding fifteen feet and such capacity exceeding ten acre-feet, they shall be constructed in accordance with section 37-87-105.
3. Such reservoirs may be constructed with a capacity in excess of two acre-feet if, at or below the two acre-feet level, an ungated outlet tube is installed, with twelve inches minimum diameter and large enough to assure adequate capacity to drain within thirty-six hours any impoundment in excess of two acre-feet.
4. The state engineer shall prepare and keep on file in his office standard specifications for erosion control dams which shall be subject to revision by the state engineer and shall in general be used as a guide by persons proposing to construct such dams.

C.R.S. 73, 33-22-114 **Destruction of Dens, Dams, Houses**  
It is unlawful for any person to destroy or damage any beaver or muskrat house, den, or dam except when the same is impeding waterflow or otherwise causing damage to property, in which case the animals and the obstructions may be removed.

C.R.S. 73, 37-84-115 **Gauge Rods**  
A gauge rod, marked in feet and tenths and one-hundredths of a foot, shall be permanently fixed and maintained at the outlets of all reservoirs, under the supervision of the division engineer, and if any owner or possessor of any reservoir fails or refuses to provide, fix, and maintain such gauge rod then the owner or possessor of such reservoir shall not be entitled to impound any water whatever in said reservoirs until the provisions of this section are fully complied with. Notwithstanding the foregoing the division engineer may determine that such rod is not necessary with respect to specific reservoirs. Such determination shall be in writing and may be rescinded in writing at any time.

C.R.S. 73, 37-92-502 **Orders as to Waste, Diversion, Distribution of Water.**

6. The state engineer and the division engineers and their duly authorized assistants and staff have the authority and duty to enter upon, and to order any person to permit the entry upon, private property at any reasonable time to inspect the various means or proposed means of diversion, transportation, and storage and the uses to which water is being, or is proposed to be, put and to read meters, gauges, and other measuring devices.
7. The state engineer, division engineer, and their duly authorized assistants have the power and duty to issue orders so that the streams of the state may be kept clear of unnecessary dams or other obstructions which may restrict or impede the flow of water to the water users of the state.

C.R.S. 73, 35-49-101 **Short Title.**  
This article shall be known and may be cited as the "Livestock Water Tank Act of Colorado."

C.R.S. 73, 35-49-102 **Legislative Declaration**  
It is the policy of the State of Colorado to encourage and improve range conditions for livestock within its borders through the construction of watering tanks, to provide a system of priorities of right of use thereof, and to protect adjudicated water rights and the public interest by providing an official record and reasonable public supervision of such watering tanks.

C.R.S. 73, 35-49-103 **Definition**  
As used in this article, unless the context otherwise requires:

1. "Livestock water tanks" includes all reservoirs created by dams constructed after April 17, 1941, on watercourses, the channels of which are normally dry as determined by the state engineer, having a capacity not exceeding ten acre feet and a vertical height not exceeding fifteen feet from the bottom of the channel to the bottom of the spillway to be used for stock watering purposes.

C.R.S. 73, 38-2-101 **Who May Condemn Real Estate, Rights-of-Way, or Other Rights**  
If any corporation formed for the purpose of constructing a road, ditch, reservoir, pipeline, bridge, ferry, tunnel, telegraph line, railroad line, electric line, electric plant, telephone

---

line, or telephone plant is unable to agree with the owner for the purchase of any real estate or right-of-way or easement or other right necessary or required for the purpose of any such corporation for transacting its business or for any lawful purpose connected with the operations of the company, such corporation may acquire title to such real estate or right-of-way or easement or other right in the manner provided by law for the condemnation of real estate or right-of-way. Any ditch, reservoir, or pipeline company, in the same manner, may condemn and acquire the right to take and use any water not previously appropriated.



2180H

ASPECTS OF DAM SAFETY

COURSE CRITIQUE

DATE OF TRAINING

The State Engineer's Office thanks you for your active participation in our Dam Safety Program. Any comments or suggestions you have are appreciated.

What do you consider the strong points of the training? \_\_\_\_\_

---

---

---

---

---

What do you consider the weak points of the training? \_\_\_\_\_

---

---

---

---

---

What would you suggest to improve the training? \_\_\_\_\_

---

---

---

---

---

What additional topics do you feel should be included in the training? \_\_\_\_\_

---

---

---

---

---

---

---

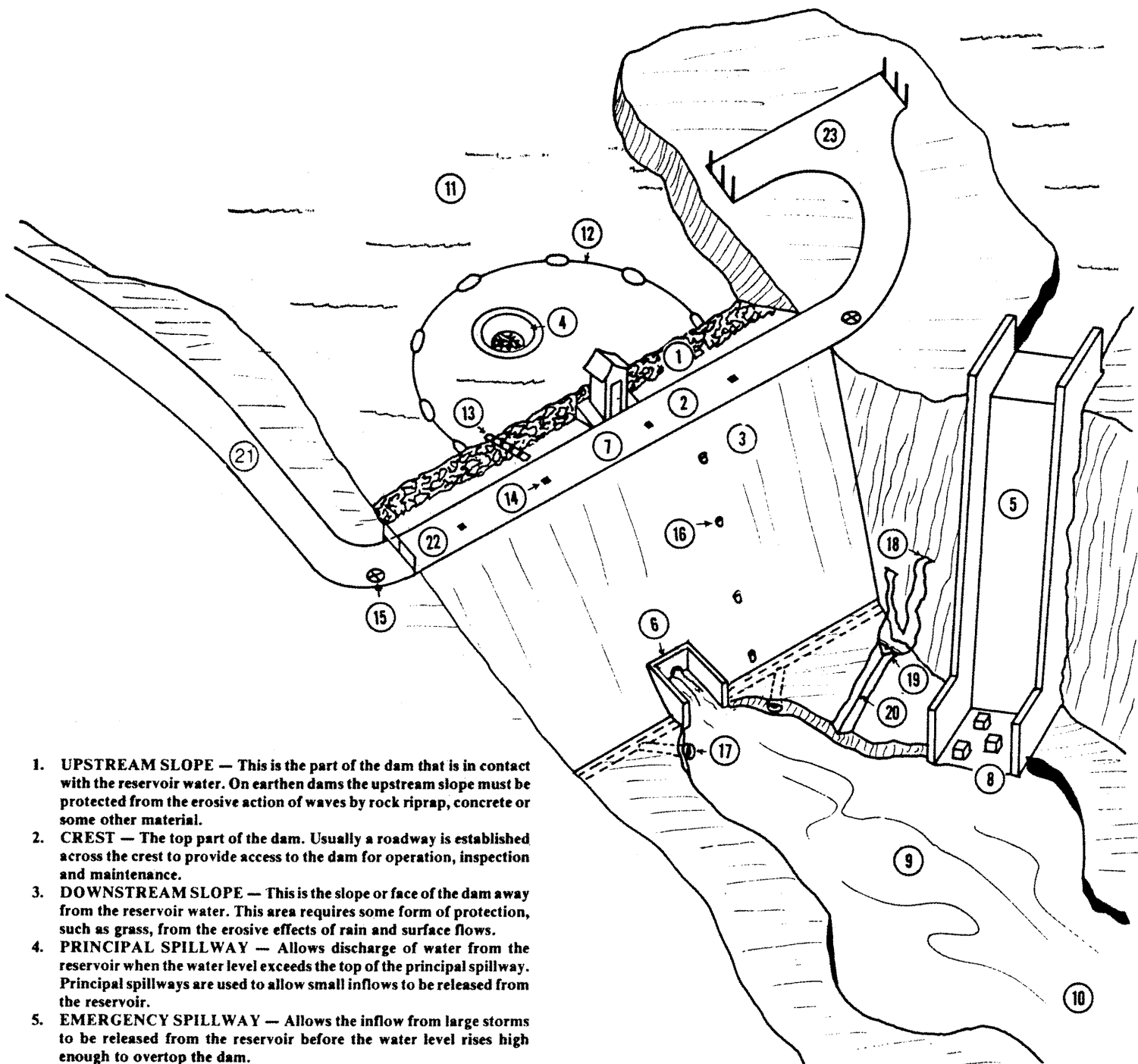

1. **UPSTREAM SLOPE** — This is the part of the dam that is in contact with the reservoir water. On earthen dams the upstream slope must be protected from the erosive action of waves by rock riprap, concrete or some other material.
2. **CREST** — The top part of the dam. Usually a roadway is established across the crest to provide access to the dam for operation, inspection and maintenance.
3. **DOWNSTREAM SLOPE** — This is the slope or face of the dam away from the reservoir water. This area requires some form of protection, such as grass, from the erosive effects of rain and surface flows.
4. **PRINCIPAL SPILLWAY** — Allows discharge of water from the reservoir when the water level exceeds the top of the principal spillway. Principal spillways are used to allow small inflows to be released from the reservoir.
5. **EMERGENCY SPILLWAY** — Allows the inflow from large storms to be released from the reservoir before the water level rises high enough to overtop the dam.
6. **OUTLET DISCHARGE STRUCTURE** — This structure protects the downstream end of the outlet pipe from erosion and is often designed to slow down the velocity of released water to prevent erosion of the stream channel.
7. **OUTLET CONTROL HOUSE** — Protects the operating mechanism for the outlet control valve from weather and from vandalism.
8. **ENERGY DISSIPATOR** — This structure slows the fast moving spillway flows in order to prevent erosion of the stream channel.
9. **STILLING BASIN** — An area where spillway flows become equal to stream flow velocities.
10. **OUTFLOW CHANNEL** — A natural stream channel that transports reservoir releases.
11. **RESERVOIR** — A manmade facility for the storage and controlled release of water.
12. **LOG AND SAFETY BOOM** — A net like device installed to prevent logs, debris or boaters from entering a water discharge facility.
13. **GAGE ROD** — A measuring device that shows the water level in the reservoir.
14. **HORIZONTAL AND VERTICAL CONTROL POINTS** — These are small monuments that are securely embedded in the surface of the dam. Any movement of the monument indicates a movement in the dam itself. Movements are detected by using accurate survey procedures.

15. **PERMANENT MONUMENT** — Fixed monuments placed away from the dam which allow movements in the control points to be observed by using accurate survey procedures.
16. **PIEZOMETER (OPEN WELL)** — Allows the level of saturation within the dam to be measured.
17. **TOE DRAIN AND OUTFALL** — Carry seepage water away from the dam and can allow seepage quantities to be measured.
18. **ABUTMENT SEEPAGE** — Reservoir water that moves through seams or pores in the natural abutment material and exits as seepage.
19. **V-NOTCH WEIR** — A device for measuring the flow of water.
20. **SEEPAGE OUTFLOW DITCH** — A shallow ditch that is excavated to prevent seepage water from collecting in ponds.
21. **ACCESS ROAD** — A roadway that provides access to the dam.
22. **ACCESS GATE** — A sturdy gate to prevent unauthorized access and discourage vandalism.
23. **TURN AROUND** — Provided for the convenience of maintenance vehicles.

FIGURE 3.1-1  
TYPICAL DAM SITE