

Interregional Connectivity Study Final Report



CDOT Division of Transit and Rail

January 2014



Interregional Connectivity Study

Final Report



Prepared By:



January 2014

Contents

Acronyms and Abbreviations.....	vii
Section 1: Introduction	1-1
1.1 Introduction.....	1-1
1.2 Study Background.....	1-1
1.3 Study Objectives.....	1-1
1.3.2 Study Area.....	1-2
1.3.3 Related Studies Affecting the ICS	1-2
Section 2: Purpose and Need Statement.....	2-1
2.1 Introduction.....	2-1
2.2 Purpose.....	2-1
2.2.1 Needs	2-1
2.2.2 Goals, Critical Success Factors, Risks, and Mitigations	2-7
Section 3: Evaluation Process	3-1
3.1 Overview	3-1
3.1.1 Key Milestones.....	3-1
3.2 Evaluation Criteria.....	3-2
Section 4: Level 1 Evaluation	4-1
4.1 Development of Segments and Scenarios.....	4-1
4.1.1 Building on Previous Studies.....	4-1
4.1.2 Performance-Based Criteria.....	4-2
4.1.3 FRA Requirements	4-2
4.2 Description of Level 1 Segments	4-2
4.2.1 Segment Descriptions	4-2
4.3 Scenario Descriptions	4-9
4.3.1 A-Series Scenarios: Through the Denver Metropolitan Area	4-9
4.3.2 B-Series and C-Series Scenarios: Around the Denver Metro Area	4-21
4.4 Evaluation of Level 1 Segments and Scenarios	4-33
4.5 Evaluation of Technologies	4-34
4.6 Level 1 Segments.....	4-34
4.7 Level 1 Scenarios	4-36
Section 5: Level 2 Evaluation	5-1
5.1 Scenarios Carried Forward from the Level 1 Evaluation	5-1
5.1.1 Additional Segments Resulting from the Level 1 Evaluation	5-1
5.1.2 Packaging and Modification of Level 2 Scenarios.....	5-1
5.2 Level 2 Evaluation Commitments.....	5-2
5.2.1 Engineering Studies.....	5-2
5.2.2 Planning Studies.....	5-2
5.2.3 Public Involvement	5-2
5.3 Level 2 Evaluation Methodologies	5-3
5.3.1 Engineering and Cost Estimating Methodology.....	5-3
5.3.2 Level 2 Service Plan Methodology.....	5-3
5.3.3 Level 2 Operations and Maintenance (O&M) Cost Methodology	5-4
5.3.4 Ridership and Revenue Estimation Methodology	5-5
5.3.5 Public Benefits and Environmental Analysis Methodology	5-8
5.3.6 Benefit/Cost Analysis Methodology	5-8

5.4	Description of Level 2 Scenarios.....	5-9
5.4.1	Scenario A-1: Direct Through Denver	5-9
5.4.2	Scenario A-5: Eastern Beltway	5-15
5.4.3	Scenario B-2A: Denver Periphery Excluding Northwest Quadrant.....	5-18
5.4.4	Scenario B-5: Denver Periphery Excluding the Southwest Quadrant.....	5-21
5.4.5	Scenario C-1: Denver Periphery Shared Track with RTD.....	5-24
5.5	Evaluation of Level 2 Scenarios	5-28
5.5.1	Level 2 Evaluation Criteria	5-28
5.5.2	Public Benefits	5-28
5.5.3	Transportation Benefits	5-29
5.5.4	Environmental Issues	5-40
5.5.5	Engineering Feasibility	5-46
5.5.6	Operations and Maintenance Costs	5-51
5.5.7	Planning Feasibility	5-51
5.5.8	Benefit/Cost Analysis	5-53
5.5.9	Financial Considerations	5-55
5.6	Recommendations for Level 3 Evaluation.....	5-55
5.6.1	Scenarios Retained.....	5-55
5.6.2	Scenarios Set Aside	5-57
5.6.3	Segments Set Aside.....	5-57
Section 6: Level 3 Evaluation		6-1
6.1	Level 3 Evaluation Commitments.....	6-1
6.1.1	Planning Studies.....	6-1
6.1.2	Engineering Studies.....	6-1
6.1.3	Public Involvement	6-1
6.2	What We Have Learned	6-2
6.2.1	Public Benefits	6-2
6.2.2	Transportation Benefits	6-2
6.2.3	Environmental Considerations.....	6-2
6.2.4	Engineering	6-2
6.2.5	Financial	6-3
6.3	Selection and Configuration of the ICS LPA.....	6-3
6.3.1	Description of the ICS LPA.....	6-4
6.4	Value Engineering Inputs to the ICS LPA	6-6
6.4.2	Other Modifications to the ICS LPA at Level 3	6-10
6.4.3	OPEX Cost Reductions.....	6-10
6.5	Consequences of Implementing the ICS LPA.....	6-11
6.5.1	Public Benefits	6-11
6.5.2	Transportation Benefits	6-13
6.5.3	Environmental.....	6-20
6.5.4	Engineering Feasibility	6-24
6.5.5	Planning Feasibility	6-26
6.5.6	Level 3 Evaluation Benefit/Cost Analysis (BCA).....	6-26
Section 7: Public Process		7-1
7.1	Results of the Level 1 Evaluation Public Involvement Process	7-1
7.1.1	Stakeholder Engagement.....	7-1
7.2	PMT and PLT Engagement.....	7-2
7.2.1	Internal Team Chartering.....	7-2
7.2.2	PLT Workshop – June 2012	7-2
7.2.3	PLT Workshop – July 2012	7-3

7.3	Public Stakeholder Engagement.....	7-3
7.3.1	Public Open Houses	7-4
7.4	Level 2 Evaluation Public Involvement Process.....	7-6
7.4.1	Project Leadership Team Engagement	7-6
7.4.2	PLT Workshop 3 – December 10, 2012.....	7-6
7.4.3	PLT Meeting 4 – February 26, 2013	7-7
7.4.4	PLT Meeting 5 – April 17, 2013	7-8
7.4.5	PLT Meeting 6 – May 1, 2013	7-8
7.5	Public Engagement.....	7-9
7.5.1	Public Open Houses – May/June 2013	7-9
7.5.2	Written Feedback	7-10
7.6	Level 3 Evaluation Public Involvement Process.....	7-11
7.6.1	Project Leadership Team Engagement	7-11
7.6.2	PLT Meeting 7 – August 13, 2013	7-11
7.6.3	PLT Meeting 8 – September 17, 2013.....	7-11
7.6.4	PLT Meeting 9 – October 15, 2013	7-12
7.6.5	PLT Meeting 10 – December 18, 2013.....	7-12
7.6.6	Public Open Houses – November 2013	7-13
Section 8: Implementation Plan.....		8-1
8.1	Phasing Recommendations.....	8-1
8.1.1	Levels of Phasing Considered.....	8-1
8.1.2	Methodology for Setting MOS Priorities	8-1
8.2	Initial MOS Screening	8-1
8.2.1	Evaluation Criteria.....	8-6
8.2.2	Methods to Improve Cost-Effectiveness	8-6
8.2.3	Initial MOS Screening Results	8-6
8.2.4	Final MOS/IOS Screening	8-9
8.2.5	Configuration Changes.....	8-9
8.2.6	Small (<\$3 Billion) MOS Options.....	8-13
8.2.7	Medium (>\$3 to \$6 Billion) MOS Options.....	8-13
8.2.8	IOS Options	8-13
8.2.9	Recommendations.....	8-13
8.3	Conceptual Financial Plan	8-14
8.3.1	Operational Viability	8-14
8.3.2	Project Payback.....	8-14
8.3.3	Project Cash Flow.....	8-17
8.3.4	Project Performance	8-17
8.3.5	Potential Sources of Funding	8-20
8.3.6	Sources of Public Financing	8-26
Section 9: References		9-1

Exhibits

- Exhibit 1-1: ICS and AGS Study Areas
- Exhibit 1-2: Interface between the ICS, AGS and I-70 Co-Development Projects
- Exhibit 2-1: Projected Increase in ADT by Year 2035
- Exhibit 2-2: 2035 Congested Highway Infrastructure
- Exhibit 2-3: Goals, Critical Success Factors, Risks, and Mitigations
- Exhibit 3-1: Alternatives Evaluation Process
- Exhibit 3-2: Level 1 Evaluation Criteria
- Exhibit 3-3: Level 2 and Level 3 Evaluation Criteria
- Exhibit 4-1: ICS Segment Names by Geographic Area
- Exhibit 4-2: ICS Scenarios
- Exhibit 4-3: ICS Summary
- Exhibit 4-4: I-70/C-470 to Central Denver Segments
- Exhibit 4-5: Central Denver to DIA Segments
- Exhibit 4-6: North Denver to South Denver
- Exhibit 4-7: Beltway Segments
- Exhibit 4-8: Denver to Fort Collins Segments
- Exhibit 4-9: Denver to Colorado Springs and Pueblo Segments
- Exhibit 4-10: Scenario A-1: Direct Alignments through Denver
- Exhibit 4-11: Scenario A-2: Beltway Excluding Southwest Quadrant
- Exhibit 4-12: Scenario A-3: Beltway Excluding Northwest Quadrant
- Exhibit 4-13: Scenario A-4: Western Beltway
- Exhibit 4-14: Scenario A-5: Eastern Beltway
- Exhibit 4-15: Scenario A-6: Complete Beltway
- Exhibit 4-16: Scenario B-1: Denver Periphery
- Exhibit 4-17: Scenario B-2: Denver Periphery Excluding Southeast Quadrant
- Exhibit 4-18: Scenario B-2A: Denver Periphery Excluding NW Quadrant
- Exhibit 4-19: Scenario B-3: Denver Periphery Eastern Beltway
- Exhibit 4-20: Scenario B-4: Denver Periphery Full Beltway
- Exhibit 4-21: Scenario C-1: Shared Track with RTD
- Exhibit 4-22: Technology Categories
- Exhibit 4-23: Summary of Segment Scoring – Level 1 Evaluation
- Exhibit 4-24: Summary of HST Scenarios Carried Forward
- Exhibit 5-1: Operating Cost Categories and Drivers
- Exhibit 5-2: Average Operating Cost per Train Mile by Technology
- Exhibit 5-3: Illustration of the Forecasting Approach
- Exhibit 5-4: Scenario A-1: Direct Alignments through Denver
- Exhibit 5-5: Scenario A-5: Eastern Beltway
- Exhibit 5-6: Scenario B-2A: Denver Periphery Excluding Northwest Quadrant
- Exhibit 5-7: Scenario B-5: Denver Periphery Northwest Quadrant
- Exhibit 5-8: Scenario C-1: Shared Track with RTD
- Exhibit 5-9: Level 2 Vital Statistics
- Exhibit 5-10: AGS and ICS Annual Ridership, Revenue, Vehicle Miles Traveled, and Reduction in Hours of Travel by Scenario
- Exhibit 5-11: AGS and ICS Distribution of Ridership by Scenario
- Exhibit 5-12: Scenario A-1A Ridership
- Exhibit 5-13: Scenario A-1B Ridership
- Exhibit 5-14: Scenario A-5A Ridership
- Exhibit 5-15: Scenario A-5B Ridership

-
- Exhibit 5-16: Scenario B-2A Ridership
 - Exhibit 5-17: Scenario B-4 Ridership
 - Exhibit 5-18: Scenario C-1 Ridership
 - Exhibit 5-19: AGS and ICS Station Boardings by Scenario
 - Exhibit 5-20: Fort Collins To/From Travel Times
 - Exhibit 5-21: Colorado Springs To/From Travel Times
 - Exhibit 5-22: Pueblo To/From Travel Times
 - Exhibit 5-23: Eagle County Regional Airport To/From Travel Times
 - Exhibit 5-24: Impact on Aviation by Scenario
 - Exhibit 5-25: Constrained ROW on US 6 - Option B (US 6)
 - Exhibit 5-26: Environmental and Community Impacts of Options through Metro Denver
 - Exhibit 5-27: Open Construction on E-470
 - Exhibit 5-28: Environmental and Community Impacts of Options around Denver
 - Exhibit 5-29: HST Construction through Longmont (N-1)
 - Exhibit 5-30: HST along I-25 (N-2)
 - Exhibit 5-31: Environmental and Community Impacts of N-1 versus N-2
 - Exhibit 5-32: Environmental and Community Impacts of the I-25 South Segment
 - Exhibit 5-33: Threading the Alignment Through the I-70 and I-76 Interchange
 - Exhibit 5-34: Alignment in Median of South Santa Fe between Hampden and Oxford
 - Exhibit 5-35: From Median of Santa Fe, elevated Alignment over Northbound Lanes, County Line Road, Two Railroads, C-470, and the Santa Fe/C-470 Flyover Ramp
 - Exhibit 5-36: Shifting from One Side of E-470 to the Other Through Chambers Road and Jordan Road Interchanges Sets Up Flatter Alignment to Avoid Sharp S-Curves at Parker Road Interchange
 - Exhibit 5-37: Comparison Chart for North Route to Fort Collins from Public Workshop No. 2 on June 5, 2013
 - Exhibit 5-38: Restricted ROW in Railroad Alignment Through Central Colorado Springs
 - Exhibit 5-39: Capital Costs by Scenario (ICS Project only)
 - Exhibit 5-40: OPEX by Scenario (ICS Project only)
 - Exhibit 5-41: Summary B/C Results by Scenario (ICS only)
 - Exhibit 5-42: Segment S-3: I-25
 - Exhibit 5-43: Segment N-2: I-25
 - Exhibit 5-44: Summary of HST Scenarios Recommended for Level 3 Evaluation

 - Exhibit 6-1: Remaining Scenarios
 - Exhibit 6-4: LPA-NWQ
 - Exhibit 6-3: LPA-I-76
 - Exhibit 6-2: LPA-BasE
 - Exhibit 6-5: lpa-Base with VE Option 1 (without Vehicles)
 - Exhibit 6-6: LPA-Base with VE Option 2 (WITHOUT VEHICLES)
 - Exhibit 6-7: ICS LPA's Fulfillment of the Project purpose and Need
 - Exhibit 6-8: Schematic Diagrams of the Alignments and Ridership Markets for the ICS LPA Options
 - Exhibit 6-9: 2035 Ridership Forecast Summary for the HST Vision Program
 - Exhibit 6-10: I70, I25N, I25S and DEN Markets and their Stations
 - Exhibit 6-11: 2035 Ridership (millions) by Market
 - Exhibit 6-12: 2035 Revenue Forecasts (millions 2012 \$) by Market
 - Exhibit 6-13: 2035 Station Boardings for the hst Vision pROGRAM
 - Exhibit 6-14: 2035 Segment Volumes for the hst Vision pROGRAM
 - Exhibit 6-15: VMT and VHT Reductions (millions) FOR THE hst vision Program
 - Exhibit 6-16: Revenue Maximizing Fare Analysis for the Intercity Market only
 - Exhibit 6-17: LPA-Base Revenue-Maximizing Analysis at Market-Pair Level
 - Exhibit 6-18: c-470 alignment
 - Exhibit 6-19: Potential Impacts to Parkland
 - Exhibit 6-20: c-470 alignment near highlands Ranch

Exhibit 6-21: Alignment Near Sheridan Boulevard
Exhibit 6-22: Alignment near Wadsworth Boulevard
Exhibit 6-23: Alignment between Kipling Street and Ward Road
Exhibit 6-24: Potential Residential Impacts
Exhibit 6-25: Revised CAPEX Estimates (Billion \$)
Exhibit 6-26: Revised OPEX Estimates
Exhibit 6-27: Benefit/cost analysis results for Level 3 Evaluation

Exhibit 7-1: Public Process
Exhibit 7-2: Milestone Workshop Process

Exhibit 8-1: MOS Options Considered in the Level 3 Evaluation
Exhibit 8-2: Initial Screening of MOS Options: North to Fort Collins (Based on Level 2 Evaluation cost estimates)
Exhibit 8-3: Initial Screening MOS Options: South to Colorado Springs (Based on Level 2 Evaluation cost estimates)
Exhibit 8-4: Initial Screening MOS Options: DIA to Monument (Based on Level 2 Evaluation cost estimates)
Exhibit 8-5: Initial Screening MOS Options: AGS: West Suburban STATION to Breckenridge (Based on Level 2 Evaluation cost estimates)
Exhibit 8-6: Final mos/ios screening (Based on Level 3 cost estimates)
Exhibit 8-7: Net Cash Flow from Operations – MOS 1A: DIA to Fort Collins
Exhibit 8-8: Net Cash Flow from Operations – MOS 3: DIA to Briargate
Exhibit 8-9: Net Cash Flow from Operations – IOS - ICS
Exhibit 8-10: Net Cash Flow from Operations – HST Vision
Exhibit 8-11: Conceptual Cash Flow Requirements – MOS 1A: DIA to Fort Collins
Exhibit 8-12: Conceptual Cash Flow Requirements: MOS 3: DIA to Briargate
Exhibit 8-13: ICS IOS: (Fort Collins/DIA/Briargate)
Exhibit 8-14: HST Vision
Exhibit 8-15: Stakeholder Evaluation of Revenue-generating Tax Alternatives
Exhibit 8-16: Sales Tax Requirements by Phase

Appendices (Volume II)

Appendix A: Level 1 and 2 Evaluation Matrices
Appendix B: ICS Engineering Reports and Supporting Information
Appendix C: Service Plans and OPEX Estimating Support Materials
Appendix D: ICS Demand Forecasting Model Documentation
Appendix E: Sources of Funding: Interregional Connectivity Study for High-Speed Transit in Colorado
Appendix F: Environmental Methodologies Manual (September 2012)

Appendices (Volume III)

Appendix G: Conceptual Plan Set

Acronyms and Abbreviations

AGS	Advanced Guideway System
B/C	benefit/cost
BEA	Bureau of Economic Analysis
CML	Consolidated Main Line
CR	County Road
DIA	Denver International Airport
DUS	Denver Union Station
CADD	computer-aided design and drafting
CAPEX	capital expenditures
CDOT	Colorado Department of Transportation
COS	Colorado Springs Airport
CPI-U	Consumer Price Index – Urban Consumers
CRT	commuter rail transit
DRCOG	Denver Regional Council of Governments
EB	eastbound
EGE	Eagle County Regional Airport
EIS	Environmental Impact Statement
EOL	End of Line
FAA	Federal Aviation Administration
FAR	floor to area ratio
FRA	Federal Railroad Administration
FTA	Federal Transportation Administration
HSIPR	High-Speed Intercity Passenger Rail
HSR	high-speed rail
HST	high-speed transit
ICS	Interregional Connectivity Study
LRT	light rail transit
Maglev	magnetic levitation
MOS	Minimum Operable Segment
MPH	miles per hour
MPO	Metropolitan Planning Organization
NB	northbound

NEPA	National Environmental Policy Act
O&M	operations and maintenance
OPEX	operating expenditures
OR	operating ratio
PEIS	Programmatic Environmental Impact Statement
PLT	Project Leadership Team
PMT	Project Management Team
PN	Purpose and Need
PW	Present Worth
RIMS II	Regional Input-Output Modeling System
RMMA	Rocky Mountain Rail Authority
ROD	Record of Decision
ROW	right-of-way
RTD	Denver Regional Transportation District
SCC	Standard Cost Categories
SOW	Statement of Work
SP	Stated Preference
TAZ	traffic analysis zone
TOD	transit oriented development
UPRR	Union Pacific Railroad
VHT	vehicle hours of travel
VMT	vehicle miles traveled
WB	westbound

Section 1: Introduction

1.1 Introduction

This document presents the Alternatives Analysis of the Interregional Connectivity Study (ICS), which evaluated the engineering, environmental, and financial feasibility of implementing High-Speed Transit (HST) in Colorado.

Section 1, Introduction, presents the study background and other past and ongoing studies that have influenced the ICS evaluation.

Section 2, Purpose and Need Statement, documents the Purpose and Need that each of the successful ICS alternatives must fulfill. Additionally, this section includes the critical success factors, risks to project success and measures to mitigate these risks.

Section 3, Evaluation Process, describes the evaluation methodology used to gain stakeholder agreement at each of the key project milestones – Level 1 Evaluation, Level 2 Evaluation, Level 3 Evaluation, and the Implementation Plan.

Section 4, Level 1 Evaluation, presents the initial, Level 1, process of used to identify and analyze the conceptual scenarios.

Section 5, Level 2 Evaluation, and **Section 6, Level 3 Evaluation**, present the increased levels of analyses required to reduce the remaining scenarios to a Locally Preferred Alternative (LPA).

Section 7, Implementation Plan, outlines the approach for implementing HST, including possible phasing of the LPA, financial options, and a potential regulatory strategy.

Section 8, Public Process, describes the public involvement process that used to obtain input and gain endorsement for implementation of the LPA.

1.2 Study Background

On June 23, 2009, the Federal Railroad Administration (FRA) issued a Notice of Funding Availability for the national High-Speed Intercity Passenger Rail Program in the Federal Register. In response, the Colorado Department of Transportation (CDOT), in concert with the Denver

Regional Transportation District (RTD), submitted an application to conduct this Colorado ICS. The focus of the ICS, as submitted for the grant, is to examine high speed technologies, alignments (paths the HST system could potentially follow), and explore financial/funding options for implementing HST along the Front Range. A critical element of the ICS (and a differentiator from past studies) is to understand the potential relationships of a Colorado HST system with RTD's transit system in the Denver metro area.

The Rocky Mountain Rail Authority (RMRA), a governmental authority made up of more than 50 local governmental entities, completed a *High-Speed Rail Feasibility Study* in March 2010 that examined HST along the I-25 Front Range and I-70 mountain corridors in Colorado.

The RMRA Study concluded that HST would be feasible within FRA guidelines on an I-25 north-south corridor from Fort Collins to Pueblo (Colorado Front Range Corridor), and on an I-70 (east-west) corridor from DIA to the Eagle County Regional Airport. The most feasible alignment and technology were identified for the purpose of ascertaining the most favorable cost-benefit ratio, but no alignment or technology was selected or recommended.

The RMRA Study recommended further analysis of alternatives, technology, and funding strategies as a key next step for implementing HST in Colorado. The ICS was initiated to address this recommendation.

1.3 Study Objectives

The objectives of the ICS are to:

- Serve as a planning document and provide preliminary recommendations for HST alignments, technologies, and station locations and connections in the Denver metro area that will maximize ridership for the existing and proposed RTD FasTracks system and future HST service.
- Identify potential future HST connections with the RTD FasTracks transit program.

- Determine optimal locations for a north-south (Colorado Front Range Corridor) HST alignment from Fort Collins to Pueblo, and an east-west HST alignment from Denver International Airport (DIA) to Jefferson County.

Study Results

The ICS will enable CDOT to:

- Evaluate the benefits, technical feasibility, and cost-effectiveness of implementing HST in Colorado.
- Determine how the proposed HST could best connect with existing and proposed RTD transit improvements in metro Denver.
- Build on previous planning efforts to develop recommendations for HST.
- Articulate a vision for HST in Colorado.
- Engage stakeholders and build support and awareness of HST.
- Develop an incremental and adaptive implementation plan that provides a practical path forward to advance the state’s HST vision.

1.3.2 Study Area

The study area for the ICS is shown on **Exhibit 1-1**. Study area limits include DIA to the east, the City of Fort Collins to the north, the City of Pueblo to the south, and the C-470/I-70 Interchange to the west.

CDOT is also conducting an Advanced Guideway System (AGS) Feasibility Study to examine high-speed options from Denver to Eagle through the I-70 mountain corridor. The two studies are dependent on one another in planning a comprehensive future HST system.

1.3.3 Related Studies Affecting the ICS

Several key previous plans and studies have set the foundation for the ICS. The recommendations made in these studies have been publicly endorsed through the planning process and have been incorporated into the results of the ICS. Relevant highlights of each study are discussed below.

EXHIBIT 1-1: ICS AND AGS STUDY AREAS

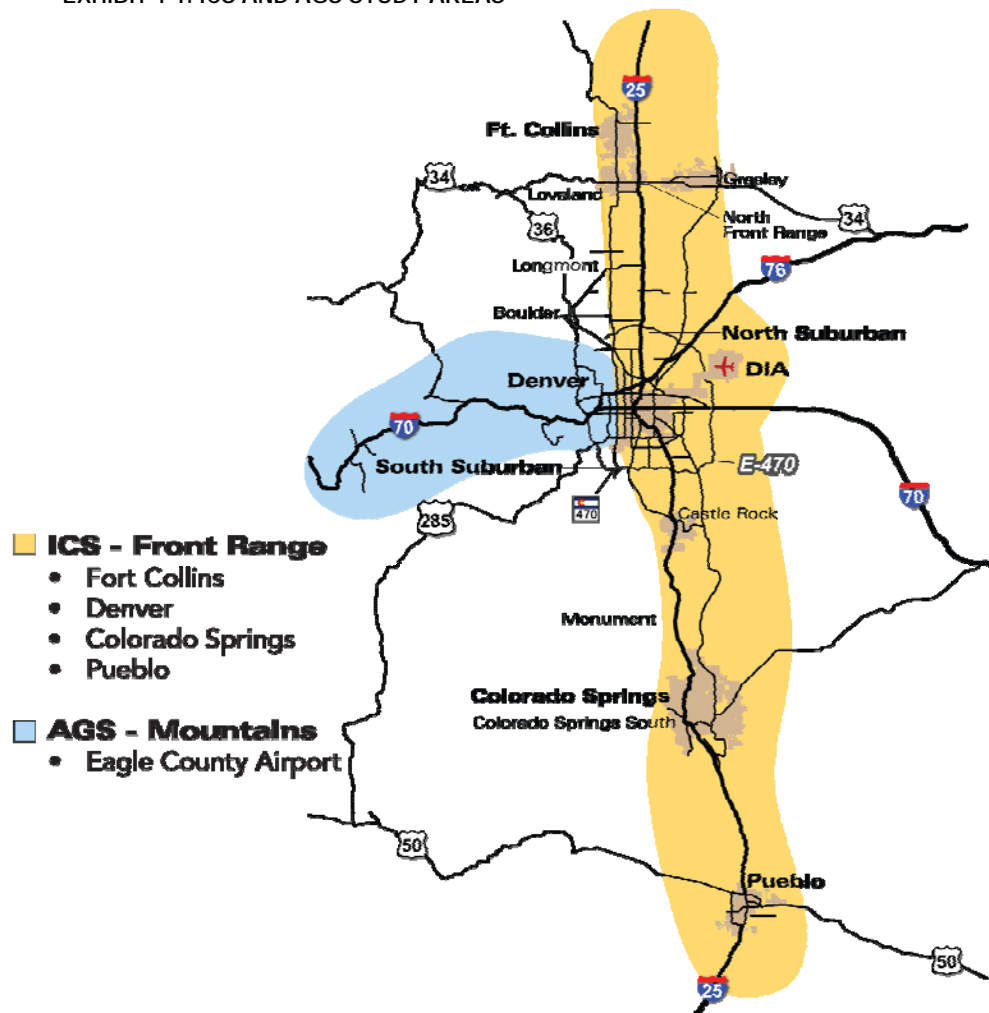

CDOT – 2035 Statewide Long Range Transportation Plan – Moving Colorado: Vision for the Future, March 2008

The Colorado Statewide Long Range Transportation Plan provides the mission and vision for the future, identifies key issues and trends affecting future planning, defines corridor visions, and recommends financial solutions for Colorado's multimodal transportation system. CDOT's mission is to provide a multimodal transportation system that enhances quality of life and the environment with convenient linkages among modal choices. To meet the transportation challenges facing the state, fulfill its mission, and achieve its vision, CDOT must work collaboratively with other agencies and stakeholders to maximize transportation investments and meet travel demand across the state. HST is an important component of the collective vision for Colorado's multimodal transportation system.

Rocky Mountain Rail Authority – High-Speed Rail Feasibility Study, March 2010

The ICS study team used the RMRA's *High-Speed Rail Feasibility Study* (RMRA Study) as a starting point to investigate further and confirm potential technologies and alignments. The RMRA determined that HST is feasible on the I-70 and I-25 corridors based on FRA criteria. High-speed transit is defined by FRA as a system capable of speeds in excess of 90 mph.

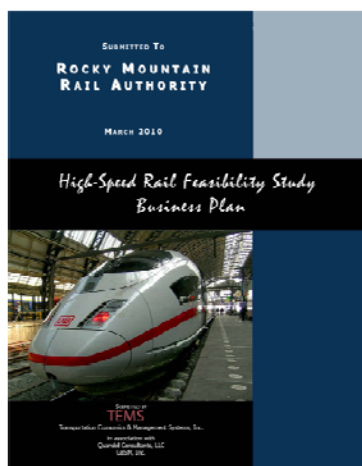

CDOT's Mission

- Provide the best multi-modal transportation system for Colorado that most effectively moves people, goods, and information.

CDOT's Vision

- Enhance the quality of life and the environment of the citizens of Colorado by creating an integrated transportation system that focuses on moving people and goods by offering convenient linkages among modal choices.

The Colorado State Freight and Passenger Rail Plan created and adopted a vision for rail improvements that can greatly enhance the effectiveness and efficiency of the state's overall transportation system:

"The Colorado rail system will improve the movement of freight and passengers in a safe, efficient, coordinated and reliable manner. In addition, the system will contribute to a balanced transportation network, cooperative land use planning, economic growth, a better environment and energy efficiency. Rail infrastructure and service will expand to provide increased transportation capacity, cost effectiveness, accessibility and intermodal connectivity to meet freight and passenger market demands through investments which included public-private partnerships."

The RMRA Study evaluated multiple constrained (using rail and/or highway rights of way) and unconstrained (greenfield) alignments to determine travel speeds and costs. Environmental impacts were not a

consideration. The study, conducted from 2007 to 2010, determined that revenue from the I-25 north-south corridor could subsidize the I-70 mountain corridor, so that the project is feasible when both are considered as a system.

The RMRA Study concluded that multiple configurations would meet FRA criteria for feasibility, but one option, the FRA-Developed Option, provided the best performance. This option

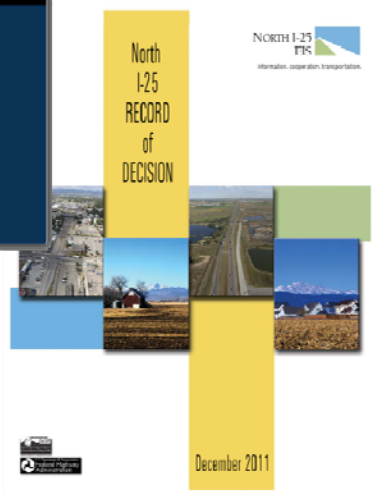

assumed the use of an unconstrained alignment from Fort Collins to Pueblo and a combination of the I-70 constrained and unconstrained alignment for the I-70 mountain corridor. The technology assumed is the very high-speed electric technology similar to the French TGV (*Train à Grande Vitesse*, meaning high-speed train).

The ICS assumes that one of the final scenarios evaluated will be similar to the FRA-Developed Option presented in the RMRA Study.

The FRA-Developed Option would provide the following:

Speeds	Average: 120 to 200 mph; maximum of 220 mph
Technology	Very high-speed electric train (TGV type)
Cost	\$21.1 billion
Operating ratio	1.90
Cost/Benefit	1.49 (\$33 billion in benefits)
Ridership	\$35 million in 2035
Service	15 to 30 minutes throughout the day
Average fare	\$0.35/mile

CDOT – North I-25 Environmental Impact Statement (EIS) and Record of Decision (ROD), December 2011

The North I-25 EIS studied transportation improvements from Denver to Fort Collins on a north-south axis and from Greeley to Longmont on the east-west axis. The Preferred Alternative includes general-purpose highway widening of I-25, the addition of tolled express lanes, express bus service, and commuter rail. The commuter rail alignment would follow the Burlington Northern Santa Fe (BNSF) alignment to Fort Collins, through Loveland, and on to Longmont, eventually terminating at RTD’s North Metro rail line. The system would largely be single track and serve nine stations. Because this alternative has a ROD, it is assumed that it will represent the constrained alignment from Denver to Fort Collins. The North I-25 EIS was conducted from 2003 to 2011.

CDOT – State Freight and Passenger Rail Plan, March 2012

With the help of public and private stakeholders and the cooperation of the FRA, CDOT developed Colorado’s first statewide Freight and Passenger Rail Plan (Rail Plan). The Rail Plan provides guidance for investing in future rail needs and presents ways to enhance passenger and freight rail development to support economic growth and environmental sustainability. Rail infrastructure and service will expand to provide increased transportation capacity, cost effectiveness, accessibility, and intermodal connectivity to meet freight and passenger market demands through investments that include public-private partnerships.

A key aspect to the Rail Plan is the development of an accurate system description and inventory of the existing and proposed rail infrastructure. This inventory includes rail lines, facilities, and operating and service attributes from both freight and passenger perspectives.

The inventory, analysis, and recommendations of the Rail Plan are used in the ICS to ensure uniform analysis and consistency in future rail initiatives.

The Rail Plan fulfills the requirements of the Railroad Safety Enhancement Act of 2008. In addition to meeting the federal requirements, the Rail Plan will be integrated into the Statewide Long Range Transportation Plan.

CDOT – Advanced Guideway System (AGS) Feasibility Study, December 2013

The CDOT Division of Transit and Rail also conducted the AGS Feasibility Study, which ran concurrently and interfaced directly with the ICS. The AGS Feasibility Study addressed the feasibility of HST technologies in the I-70 mountain corridor by soliciting responses from industry. These proposals defined technologies, costs, and the feasibility of implementing AGS in the I-70 mountain corridor. The ridership studies developed for the ICS will be used to determine the feasibility of AGS.



CDOT – I-70 Mountain Co-Development Program, Currently Underway

The purpose of the I-70 Co-Development Program is to incorporate a Public-Private Partnership (P3) to implement the transportation improvements specified in the ROD for the I-70 mountain corridor. Recommendations from the ICS and AGS studies may influence the approach taken in the Co-Development Program. It is anticipated that the ICS ridership analysis will be used and incorporated into the Co-Development strategy.

Exhibit 1-2 shows the inter-relationship among the ICS, AGS, and I-70 Co-Development projects.

Regional Transportation Plans in the ICS Study Area

It is important to understand how the Metropolitan Planning Organizations (MPOs) within the study area have addressed commuter and intercity passenger rail in their respective long-range Regional Transportation Plans (RTPs). Reviewing these RTPs allows the study team to gauge the level of public support for major transit improvements and understand how the MPOs envision the future of transportation in their respective areas. The four urbanized areas within the ICS study area (Fort Collins, Denver, Colorado Springs, and Pueblo) address commuter rail and intercity passenger rail in their RTPs. None of the RTPs identify a specific route or station location between Denver and Pueblo. The North Front Range MPO supports the selection of the Preferred Alternative in the North I-25 Corridor EIS, where the BNSF right-of-way will be used for commuter rail service.

Pikes Peak Area Council of Governments (PPACG)

The Pikes Peak region includes the urbanized areas of El Paso County, Park County, and Teller County, and the municipalities of Alma, Calhan, Colorado Springs, Cripple Creek, Fairplay, Fountain, Green Mountain Falls, Manitou Springs, Monument, Palmer Lake, Ramah, Victor, and Woodland Park. The PPACG completed the *Moving Forward Update 2035 RTP* update in January 2012. This long-range transportation plan addresses regional transportation deficiencies and identifies projects that will improve the transportation system for the region. The RTP indicates that the I-25 corridor carries the highest volume of traffic of any road in the area and is a critical roadway for linking commerce along the Front Range and the nation. In order to manage congestion, a project was proposed to construct a fixed-guideway system to connect Front Range populations to Denver and the I-70 corridor.

The RTP states that light rail, commuter rail, bus rapid transit, or street cars are all options to consider, and identifies stations located in Monument, downtown Colorado Springs, and Fountain. The RTP also describes the RMRA *High-Speed Rail Feasibility Study* (March 2010) proposal to construct a passenger rail line paralleling I-25 through the state. A specific route or stations within the Pikes Peak urbanized area are not endorsed, but the RTP acknowledges that studies are being conducted to implement intercity passenger rail in the region.

EXHIBIT 1-2: INTERFACE BETWEEN THE ICS, AGS AND I-70 CO-DEVELOPMENT PROJECTS

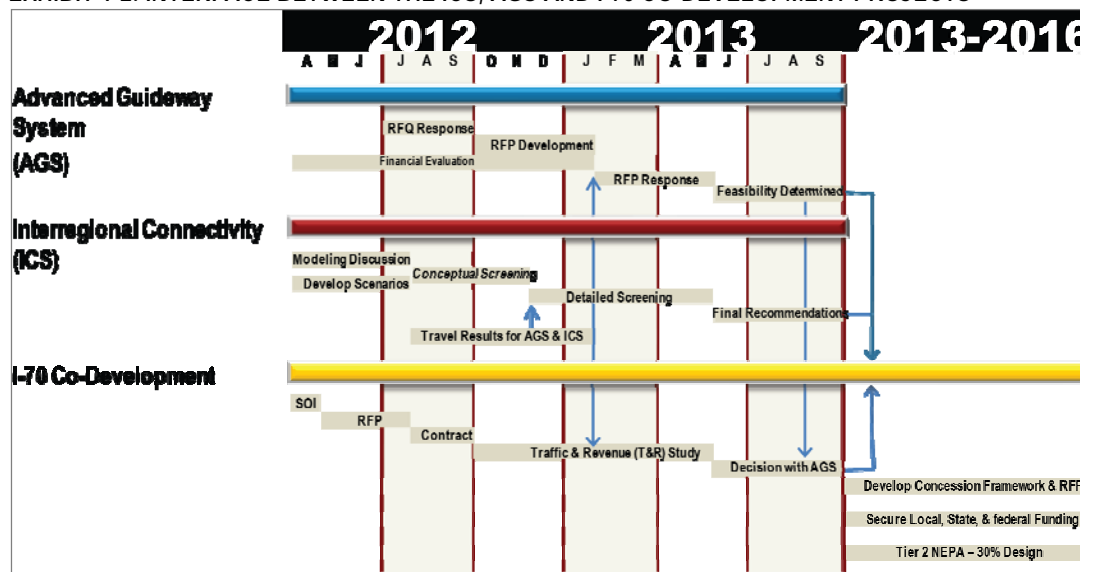

The RMRA selected one option that best met or exceeded FRA feasibility criteria to further refine, analyze, and use as a test-case scenario for developing an Implementation Plan. The option uses a very high-speed electric train on a greenfield alignment that serves Monument east of downtown Colorado Springs (Woodmen Road), Colorado Springs Airport, and Pueblo.

The RTP addresses the CDOT Rail Relocation Implementation Study, which concluded that a plan for diverting the majority of heavy freight traffic from the Joint Line (the existing rail route from Denver through Colorado Springs to Pueblo) to east of the Front Range, allowing the line to be used for intercity passenger rail service, should be studied further.

Denver Regional Council of Governments (DRCOG)

The Denver urbanized area includes Adams, Arapahoe, Boulder, Broomfield, Denver, Clear Creek, Douglas, Jefferson, and Gilpin Counties, and the numerous municipalities within those counties.

DRCOG adopted the *2035 Metro Vision Regional Transportation Plan Update* in February 2011. The RTP states that by 2035, an additional 1.4 million residents and more than a million more jobs will place great demands on the existing transportation system. The RTP addresses the challenges and guides the development of a multimodal transportation system to accommodate this growth.

DRCOG's RTP identifies a need for routes to be added to the metro rapid transit system. The base metro rapid transit system will consist of light rail, commuter rail, and bus/bus rapid transit (BRT)/High-Occupancy Vehicles (HOV)/High-Occupancy Tolling (HOT) facilities.

The RTP envisions that the state's intercity corridors will extend from the base system to provide connections to destinations throughout Colorado. The corridors will be developed with a commuter rail or bus system and will also incorporate elements of a statewide intercity rail system. The RTP does not endorse a specific route for the HST system and does not address the RMRA *High-Speed Rail Feasibility Study* (March 2010) or any other intercity passenger rail studies in the area.

Pueblo Area Council of Governments (PACOG)

The PACOG urbanized area includes the City and County of Pueblo, Board of Water Works, School District No. 60, School District No. 70, Pueblo West Metropolitan District, Colorado City Metropolitan District, and Salt Creek Sanitation District.

PACOG adopted the *2035 Long Range Transportation Plan (LRTP) Amendment* in April 2011. The LRTP is a plan for the development of transportation programs and projects within the Pueblo area. Within the LRTP, the existing conditions of each transportation mode and the needs for each mode are identified.

On the topic of passenger rail, the LRTP discusses the RMRA *High-Speed Rail Feasibility Study* (March 2010) of passenger rail services in the I-25 and I-70 corridors. The LRTP does not endorse a specific route for the intercity rail system, but does present a figure depicting possible routes for an intercity passenger rail line that uses the greenfield alignment, not the existing rail corridor, between Denver and Pueblo that was presented in the RMRA Final Report. The figure shows a station stop in downtown Pueblo.

North Front Range Metropolitan Planning Organization (NFRMPO)

The NFRMPO urbanized area includes Weld and Larimer Counties and the Cities of Berthoud, Eaton, Evans, Fort Collins, Garden City, Greeley, Johnstown, La Salle, Loveland, Milliken, Severance, Timnath, and Windsor.

In September 2011, the NFRMPO completed and adopted the *2035 Regional Transportation Plan Update*, which supports the outcome of the North I-25 EIS, and plans to work with CDOT to implement the Preferred Alternative. The Preferred Alternative includes commuter rail along the BNSF rail corridor, express buses along I-25, and commuter buses along U.S. Highway (US) 85.

Additionally, I-25 will be widened to accommodate two new lanes between State Highway (SH) 14 and US 36. The RTP anticipates that the North I-25 EIS Phase 1 improvements will be completed by 2035. Preservation of right-of-way for commuter rail is included in Phase 1.

Section 2: Purpose and Need Statement

2.1 Introduction

This Purpose and Need Statement was written to provide the basis for developing, and subsequently evaluating, interregional transit solutions that have been examined in this ICS. The statement is made up of three components:

- Purpose
- Needs
- Goals, Critical Success Factors, Risks, and Mitigations

The Purpose specifies what CDOT is striving to accomplish with a HST system in Colorado. The Needs have been identified in previous plans and studies conducted at the local, regional, and state level to connect communities along the Front Range and on the I-70 mountain corridor with rail transit. As described in Section 1: Introduction, these plans and studies set the foundation for the ICS. Goals, critical success factors, risks, and mitigation measures specific to this study were developed by the CDOT study team and endorsed by the Project Leadership Team before being publicly vetted at the public workshops. The PLT is made up of public agency officials representing the ICS study area.

Each of these components of the Purpose and Need Statement is discussed below. Fulfillment of the Purpose and Need Statement becomes an important evaluation criterion in all levels of evaluation throughout the study process.

2.2 Purpose

A HST system would provide Colorado with a well-supported modal option for the state's transportation network that:

- Connects communities and destinations for interregional business and tourism travel
- Builds on and strengthens Colorado's existing transportation infrastructure

- Supports the state's vision, as articulated in the "State Rail Plan"
- Offers statewide social, environmental, and economic benefits that are greater than the capital and operating costs of its implementation.

Adopted Colorado Rail Vision

The Colorado rail system will improve the movement of freight and passengers in a safe, efficient, coordinated, and reliable manner.

In addition, the system will contribute to a balanced transportation network, cooperative land use planning, economic growth, a better environment, and energy efficiency. Rail infrastructure and service will expand to provide increased transportation capacity, cost effectiveness, accessibility, and intermodal connectivity to meet freight and passenger market demands through investments that include public-private partnerships.

Source: Colorado State Freight and Passenger Rail Plan, March 2012

2.2.1 Needs

As further detailed in this section, HST would meet the following identified needs of Colorado communities:

1. Address the mobility demands of future population growth.
2. Improve mobility and system capacity through provision of a travel option.
3. Enhance economic growth and development through improved connectivity.
4. Improve the State's environmental quality and energy efficiency.
5. Provide economic benefits sufficient to attract new funding sources.

1. Address the Mobility Demands of Future Population Growth

Capacity requirements continue to increase — The Colorado Department of Local Affairs, the state's official demographer, projects Colorado's population will grow from 5 million to nearly 8 million by 2040.

Population growth is projected to remain concentrated in the Front Range, where 80 percent of the state's population currently lives. Northern Front Range counties (Adams and Weld) are growing twice as fast as other areas, and high growth rates are also projected in the southern Denver metro area (Douglas County) and Colorado Springs. Population and employment growth correlate to more travel demand and increased trips, particularly throughout the Front Range.

As a result of future population growth, there is a need to provide additional trip capacity in the I-25/Front Range and I-70 east and mountain corridors. For example, the number of average daily trips (ADT) for the I-25 corridor between Denver and Fort Collins is forecast to increase more than 100 percent in the busiest sections by 2035; ADT growth for the I-70 East corridor is estimate to range from 40 to 250 percent, depending on location. In addition, ADT is anticipated to double by 2035 in the I-25 corridor between Denver and Colorado Springs and between Denver and Eagle County (See **Exhibit 2-1**).

CDOT has programmed additional highway capacity in these corridors, but given funding constraints faced by the State, that construction is not anticipated to meet total trip demand. An interregional HST network can help absorb some of the additional trip demand and can provide travel alternatives in those corridors.

Unmet travel demand — Colorado's transportation system is vital to supporting population and economic growth in the state. There is particular need to provide additional trip capacity in the I-25 and I-70 corridors, which are the backbone of the state's transportation network.

Interstates carry 40 percent of all trips in the state, despite being only 10 percent of the total lane miles. Interregional trips are particularly underserved. The Front Range MPOs estimate that less than half of

needed transit trips (359 million in 2035) can be met by the current and future transit system. Many of these unmet trips are for interregional travel. Unmet demand is also significant in the I-70 mountain corridor. Travel demand studies conducted for the *I-70 Mountain Corridor Programmatic Environmental Impact Statement (PEIS)*, completed in 2011, estimated that unmet demand accounts for up to 70,000 suppressed trips per day and that additional highway capacity alone cannot serve this demand.

An interregional HST network can help absorb additional trip demand and provide travel alternatives in those corridors, which is why both the I-70 Mountain Corridor and I-25 North RODs include interregional rail as central components of the improvements.

EXHIBIT 2-1: PROJECTED INCREASE IN ADT BY YEAR 2035

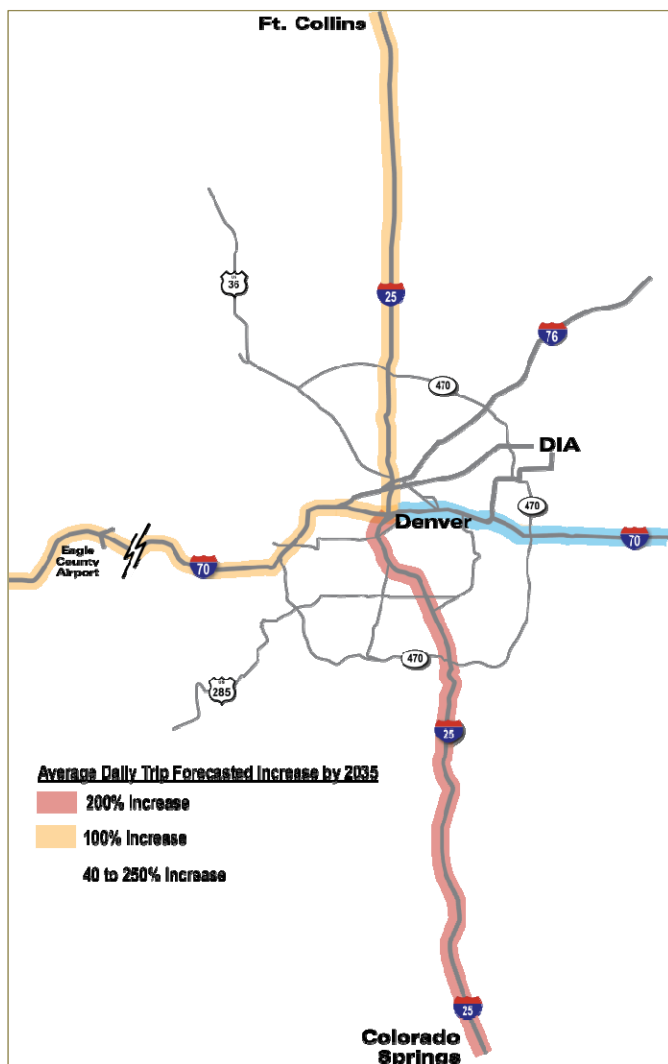

Long and unreliable travel times — Currently, travel times between and among all major destinations in the I-25 and I-70 corridors are unstable and unpredictable, primarily due to population growth and related trip demands and congestion.

Average delay per trip on congested state highways is currently 22 minutes; by 2035 this delay is expected to increase to 70 minutes. Predicted over-capacity highway infrastructure throughout Colorado is shown on **Exhibit 2-2**. Trip times are widely variable at different times of the day and the year and are significantly affected by minor incidents and weather factors. There is a need to provide shorter travel times – and better travel time reliability – throughout the corridors to maintain Colorado’s attractiveness, quality of life, and economic growth.

I-25 and I-70 are the primary corridors serving longer distance trips in Colorado. High travel volumes during peak periods on these corridors result in travel times two to three times free flow conditions. For instance:

- By year 2035, about 85 percent of I-25 in Denver and north to Fort Collins is projected to be congested and to operate over capacity during the peak periods of travel. Peak AM hour southbound travel times are expected to double by 2035, and peak-hour speeds will average only 30 mph.
- I-70 through Denver is already near or over capacity. CDOT projects that by 2030, I-70 in the Denver metro area will be congested 20 to 40 percent of the day.
- By year 2035, I-70 west of Denver will operate over capacity all day on Saturdays, Sundays, holidays, and some weekday periods. Severe

congestion (speeds averaging less than 20 mph) is predicted to occur more than 10 hours per day on Sundays in 2035. Long travel times deter travel and negatively affect mountain community economies as would-be visitors choose not to travel based on poor travel conditions.

Congested conditions make travel unpredictable even in off-peak periods. High traffic volumes also tax the highway infrastructure, contributing to congestion and poor reliability. These congested areas of I-25 and I-70 have higher-than-expected crash rates, presenting safety and reliability concerns, which are exacerbated during winter weather conditions.

In addition to supporting person trips, there is a need to improve travel time and reliability and to reduce associated costs of goods movement in Colorado. Improvements would allow the state to maintain its strong economic position and to help maintain jobs and other economic benefits provided by goods movement.

A HST system can help meet these needs in a number of ways: by freeing up trip capacity on major roadway corridors; by using the HST network to provide some cargo movement between and among major activity centers; and by providing associated economic growth and development that attracts goods providers and shippers to the state.

A HST system can help provide faster travel times between all major destinations, allowing users to bypass congestion and rely on a stable transportation network and schedule. A reliable alternative travel mode would also help reduce traffic volumes and pressures on the existing system, freeing up capacity and improving safety on the interstate system.

EXHIBIT 2-2: 2035 CONGESTED HIGHWAY INFRASTRUCTURE

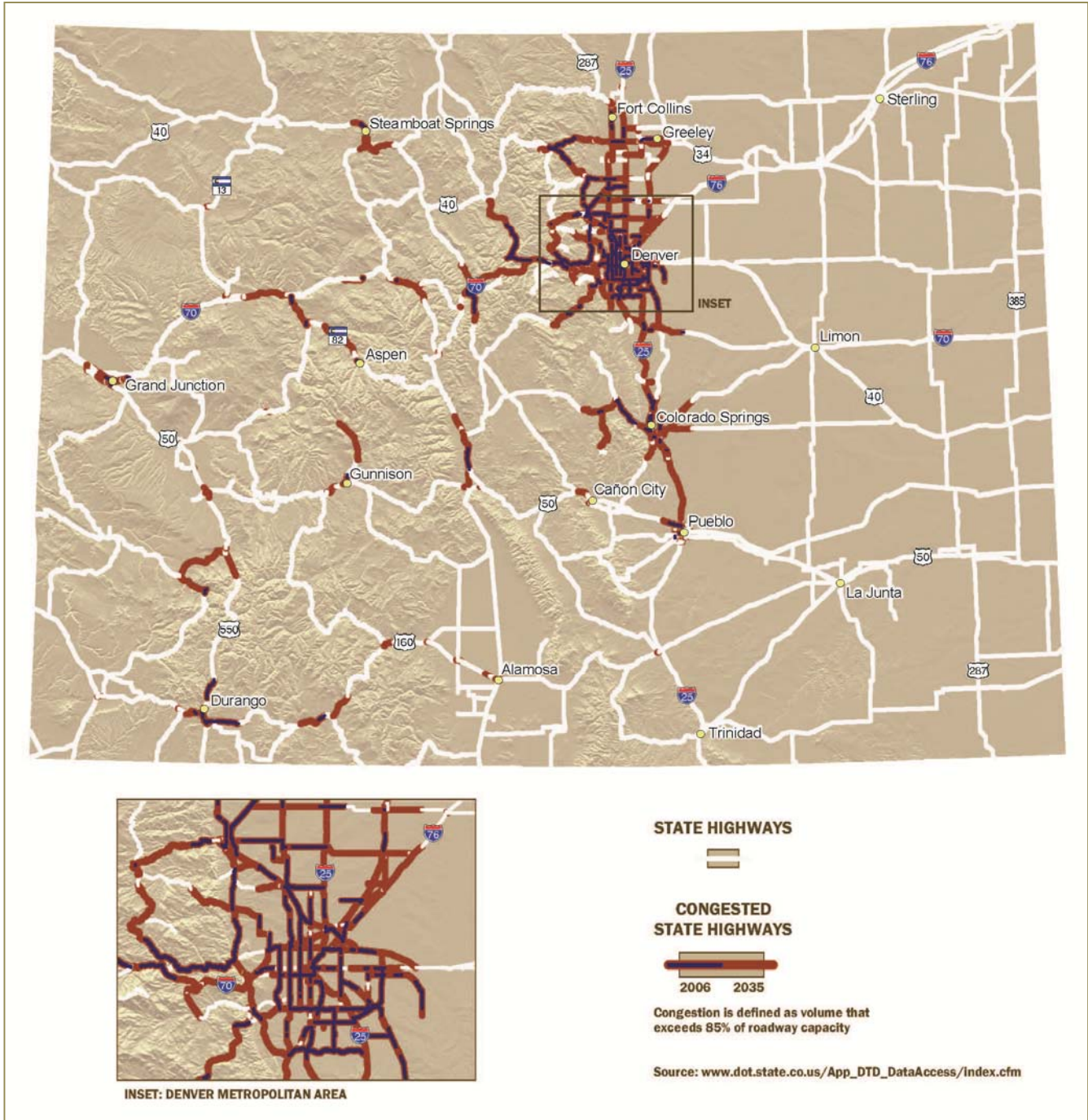

2. Improve Mobility and System Capacity Through Provision of a Travel Option

Support Colorado's multimodal, integrated transportation system — CDOT's Division of Transit and Rail is responsible for planning, developing, and integrating rail in the state-wide transportation system. Expanding transit is a key state-wide goal for mobility challenged corridors like I-25 and I-70, in large part because it frees up capacity for highway and freight rail movement. Additionally, transit and rail are highly valued by Colorado's citizens as evidenced by numerous state-wide and regional transportation studies that have found public support for increased rail service highest of all transportation options.

A recent study supported by the American Public Transportation Association found that cities with large, well-established rail systems have significantly higher per-capita transit ridership, lower average per-capita vehicle ownership and annual mileage, less traffic congestion, lower traffic death rates, lower consumer expenditures on transportation, and higher transit service cost recovery than otherwise comparable cities with less or no rail transit service. The study concludes that rail provides a backbone for transit that cannot be met by bus-only or limited rail systems. The RTD's FasTracks program is making a significant investment in providing this type of comprehensive rail system in the Denver metro area.

Enhance intercity travel options — Alternative modes of travel are very limited outside the core Denver metro area. Rural areas and satellite population centers generally have poorly connected roadways, and interregional transit service (e.g., Fort Collins to Denver) is limited or non-existent.

There is a need to expand and enhance the non-automobile modes of travel in communities throughout Colorado, especially in activity and population centers in the Denver metro area, the Front Range, and the I-70 mountain corridor. Currently, many communities do provide local transit service and promote alternative modes such as bicycling.

Integrate HST and existing passenger rail transit — Interregional rail would provide an opportunity to expand the state's rail network and provide additional trip connections to other parts of the state. The Denver RTD FasTracks program has initiated a \$7-billion vision of 120 miles of new fixed-guideway transit.

A HST system would allow convenient and cost-effective connections between the RTD FasTracks system, airports, and other transportation corridors in the state, further enhancing use of alternative modes and capitalizing on existing infrastructure investments, while providing key linkages between the Denver metro area and major activity centers throughout the state.

Implementation of HST, with its new stations and related transit-oriented development, can also encourage development or enhancement of additional alternative mode systems in communities throughout Colorado through grants or value capture that would otherwise not be available to those communities. Empirically, rail attracts more riders than other transit modes and is thus effective in creating a meaningful mode shift from highway travel.

3. Enhance Economic Growth and Development Through Improved Connectivity

Create jobs and stimulate the economy — There is a need to provide transportation options that enhance the state's economy; serve key employment, business, residential, and recreation centers; and attract economic development by competing with other states already investing in rail infrastructure.

An HST network would support communities and enhance economic growth throughout Colorado by providing convenient and affordable access for people of all income levels and in varied geographical areas to other employment centers, business centers, and residential centers throughout the state.

An HST network could also provide a new transportation mode that allows more efficient use of existing infrastructure wherever possible and improves connections between rural areas and major population centers.

Generate direct economic benefits — A HST system would provide direct economic benefits to the state through job creation and improved access, convenient connection, and attracting new businesses and employees. The public and private investments in a HST would result in benefits throughout Colorado by providing employment and supporting ongoing economic growth.

A HST would provide a significant number of employment opportunities, both short-term during its construction, and long-term during its ongoing operations. It also would provide convenient connections between employment and residential centers, providing better access to jobs throughout Colorado, and would help the state attract businesses and employees seeking a higher quality of life that is associated with integrated transportation systems, particularly rail options.

The RMRA *High-Speed Rail Feasibility Study* (March 2010) found that HST in Colorado would generate \$33 billion in benefits against a capital cost of \$21.1 billion. Further, the study predicted an operating ratio (revenues divided by operating costs) of 1.49.

Support aviation — There is a need to improve connectivity, travel times, and travel reliability between the state's major activity centers and its airports.

Aviation travel in the state is projected to double by 2035. Colorado's public airports generate \$23.5 billion in annual economic activity and are responsible for 280,000 jobs. Consequently, maintaining Colorado's economic strengths associated with its airport network is critical – not only DIA, but the strong system of regional airports at major activity centers throughout the state.

An HST would provide significant benefits to the state's airport system in a number of ways by providing additional trip options at DIA for those accessing the state; reducing congestion at feeder and regional airports (thereby freeing up capacity at those airports); and providing reliable and cost-effective accessibility options to resort areas in times of inclement weather.

Support tourism — Under unconstrained conditions, Colorado tourism is expected to double by 2035.

Tourism is the second largest industry in Colorado, generating \$750 million in local and state tax revenue in 2010. Colorado has made an investment in tourism advertising, and this investment, along with the economic recovery, has increased tourism trips to Colorado; 2010 was a record-setting year with 29 million overnight trips to the state (an increase of 6.1 percent over 2009) and spending of \$8.8 billion. Similar numbers were recorded in 2011, with Colorado continuing to record increased visitors in all segments despite a flat or declining national market.

More than 80 percent of overnight visitor spending occurs in the Front Range and mountain resort communities. Colorado continues to lead all states in the competitive overnight ski travel market, garnering approximately 19 percent of all trips in 2011.

Improve freight movements — Continued congestion on the state's highways will reduce the cost-effectiveness of overall freight movement. Further, freight volumes will need to increase to serve future growth and move goods to other growth areas in the United States.

The American Trucking Association reports that 2011 was a record year for growth of trucking tonnage nationwide, indicative of the improving economy. While 2012 is likely to be a more normal growth year (around 3 percent), interstate trucking remains a significant demand on the state's transportation infrastructure.

By reducing growth pressures on the state's highway network, HST would contribute to higher efficiencies for the movement of freight.

4. Improve the State's Environmental Quality and Energy Efficiency

Providing an alternative to highway travel has a number of social and environmental benefits, as discussed below:

- Improves land use planning and promotes livable communities.
- Provides environmental benefits to Colorado.
- Promotes energy efficiency.

Improve land use planning and promote livable communities — There is a need to support the land use goals of the state and local governments throughout the Front Range and I-70 mountain corridor related to limiting sprawl and focusing development around transit investments. The RTD FasTracks program is already working toward these goals in the Denver metro area.

An HST system can expand this philosophy throughout the state by providing the opportunity for jurisdictions along the HST corridors to focus new development near stations and to move toward sustainable transit-oriented development around transit stations.

Provide environmental benefits to Colorado — There is a need to support state goals of providing additional means and incentives to the residents of Colorado to reduce their per-capita vehicle miles travelled (VMT) and related greenhouse gas (GHG) emissions.

An HST system can help reduce reliance on the single-occupant auto for many trips throughout Colorado, helping reduce per capita VMT, lower GHG emissions, and meet air quality conformity goals. The reduction in use of petroleum products would also reduce dependence on foreign oil.

Integrating HST into the state’s transportation system would divert highway travel, provide additional capacity and travel choices, and help focus development in a more sustainable manner.

Promote energy efficiency — There is a need to support state goals of reducing per-capita energy consumption, related both to energy conservation itself (preserving future energy resources) and the environmental and fiscal cost of energy production and consumption.

A HST network can help reduce per-capita energy consumption by providing an alternative to the single-occupant auto for many trips throughout Colorado.

5. Provide Economic Benefits Sufficient to Attract New Funding Sources

According to the 2035 Statewide Long Range Transportation Plan, anticipated revenues of \$123 billion represent only about 50 percent of the cost of the multimodal vision for the state, estimated at \$249 billion. Of the total, 24 percent has been dedicated to transit. While this is a large policy commitment, there is little funding available to fulfill the transit vision.

The ability to generate local funding will be critical to obtaining federal grants. To be sustainable, the HST program will need a strong source of state and local funding commitments. To obtain the political support for new sources of revenue, the recommended program must clearly demonstrate economic and other societal benefits.

As stated above, the RMRA Study predicts highly positive benefit/cost ratios resulting from the implementation of HST in the state. Benefits at these levels should be sufficient to gain public support for revenue increases and attract private funding to the program.

The inclusion of private funding in the program would further increase support for a project at the federal level. Thus, the preferred alternative will need to realize benefit/cost ratios comparable to the RMRA Study.

2.2.2 Goals, Critical Success Factors, Risks, and Mitigations

Goals, critical success factors, risks, and risk mitigations were developed during the joint ICS/AGS chartering workshop, endorsed by the PLT and vetted through the public workshops. These goals, success factors, risks, and mitigations are summarized in **Exhibit 2-3**.

EXHIBIT 2-3: GOALS, CRITICAL SUCCESS FACTORS, RISKS, AND MITIGATIONS

Goal	Critical Success Factors	Risks	Mitigations
Develop a Persuasive Vision for HST in Colorado	<ul style="list-style-type: none"> ▪ Builds off of the State Rail Plan and other relevant transportation planning studies conducted in recent years. ▪ ICS and AGS teams work together to develop mutually supporting strategies. ▪ The vision is widely supported in all parts of the state. ▪ A logical path toward implementation is defined. ▪ Public support for local match funding is obtained. ▪ Federal funding is obtained. ▪ The program clearly demonstrates congestion, population growth, and economic development considerations. 	<ul style="list-style-type: none"> ▪ Political support is not developed and ballot measures are not adopted. ▪ Benefits are not perceived to be great enough to gain support for local funding. ▪ Communities cannot come to agreement on the path forward for implementation. ▪ Implementation of the FasTracks program is delayed. 	<ul style="list-style-type: none"> ▪ Incorporate to the maximum extent the results from previous publicly-endorsed transportation studies (State Rail Plan, I-25 North EIS, I-70 Mountain Corridor PEIS, Regional Transportation Plans, etc.) ▪ Provide combined PMTs and PLTs for the ICS and AGS studies. ▪ Gain endorsement by the agency and public stakeholders at each project milestone. ▪ Implement each of the mitigations defined below. ▪ Present key demographic, economic, and transportation challenges anticipated in the future. ▪ Develop/implement an effective media outreach strategy. ▪ Ensure vision is strong enough in the public's mind to justify sequential segments/phases and overcome public misperceptions about comparative advantages of mobility modes in the future in view of demographic, economic, and environmental trends.
Develop a Plan that Maximizes Ridership for HST and RTD's FasTracks System	<ul style="list-style-type: none"> ▪ Connectivity between the systems and modes such as transit systems, motorists, and pedestrians/bicyclists is maximized. ▪ Timely implementation of the FasTracks program. ▪ Direct links to existing population centers/development hubs. 	<ul style="list-style-type: none"> ▪ Development of competing systems for funding (federal grants, programs, etc.) with RTD/FasTracks. ▪ Too much focus on local wants without consideration of the system as a whole. ▪ Different technologies/integration. 	<ul style="list-style-type: none"> ▪ Use the travel demand model to configure the best system. ▪ Use the Context Sensitive Solutions (CSS) process to communicate the need for combined benefits for both systems. ▪ Partner with RTD and other local agencies.
Maintain Public Support at all Levels	<ul style="list-style-type: none"> ▪ Open, honest, ongoing communication reaching diverse audiences using broadcast, print, and social media. ▪ Reliable, defensible data including cost estimates, project ridership, etc. 	<ul style="list-style-type: none"> ▪ Poor public communication. ▪ Stakeholders feel excluded from decision making. ▪ Goals of the mountain communities are different than those of the Front Range communities, and vice versa. 	<ul style="list-style-type: none"> ▪ Include the mountain and Front Range communities in the decision-making process through use of combined PLT and public workshops. ▪ Demonstrate transparent integration with the AGS study and

EXHIBIT 2-3: GOALS, CRITICAL SUCCESS FACTORS, RISKS, AND MITIGATIONS

Goal	Critical Success Factors	Risks	Mitigations
	<ul style="list-style-type: none"> ▪ Transparent travel demand modelling. ▪ A broad spectrum of stakeholders is included in all key decisions. ▪ Railroad companies are engaged early on to obtain accurate information on ROW usage, costs, feasibility, alternatives, etc. ▪ Success of FasTracks to obtain support for a new rail project. ▪ Early understanding and ongoing support among key political leaders, interest groups and media. 	<ul style="list-style-type: none"> ▪ FasTracks delays or discontinuation of rail components of program. ▪ Lack of funding for HST projects due to deficits. 	<p>I-70 Co-Development.</p> <ul style="list-style-type: none"> ▪ Provide broad and effective public dissemination of findings. ▪ Use effective public and stakeholder communication to drive proactive communication and generate support among the general public as well as key opinion leaders and qualified support groups.
<p>Develop a Logical “Next Step” for Implementing HST in Colorado</p>	<ul style="list-style-type: none"> ▪ Defensible results, including ridership estimates, capital cost estimates, operating cost estimates, and financial strategies. ▪ Communicate how the initial minimal operable segment (MOS) fits into the larger picture for a state wide system. ▪ Generate public support for a phased approach resulting in the most logical (not political) first step. ▪ Document existing environmental clearances with a logical “Phased” plan to pursue additional environmental planning work. 	<ul style="list-style-type: none"> ▪ Insufficient engineering data to develop defensible ridership, capital, and operating cost estimates. ▪ Communities cannot agree on who gets the first phase of a project. ▪ No agreement is reached on a logical funding mechanism. 	<ul style="list-style-type: none"> ▪ Use Monte Carlo probability modeling to produce best case, most likely, and pessimistic estimates for ridership and costs if engineering data are insufficient. ▪ Provide additional engineering design on the most difficult, high-cost segments. ▪ Include all communities in the selection of the MOS. ▪ Demonstrate MOS benefits. ▪ Robustly engage railroads. ▪ Ensure feasibility of phased approach with all stakeholders, including railroad companies. ▪ CDOT has built trust and is positioned to referee and weigh in to resolve conflicts so MOS can move forward.
<p>Recognize HST Benefits to Colorado</p>	<ul style="list-style-type: none"> ▪ Maximize ridership through configuration of an efficient highly utilitarian system. ▪ Control the cost of the system. ▪ Obtain host community support for HST. ▪ Demonstrate improvements in land use planning, air quality, 	<ul style="list-style-type: none"> ▪ Project becomes cost-ineffective due to implementation of high-cost alignments and technology. ▪ Political pressure results in too many stations, affecting travel time and reducing ridership. 	<ul style="list-style-type: none"> ▪ Value engineer all project recommendations to be the most cost-effective possible. ▪ The consequences of political solutions in favor of the best engineering solutions need to be effectively communicated.

EXHIBIT 2-3: GOALS, CRITICAL SUCCESS FACTORS, RISKS, AND MITIGATIONS

Goal	Critical Success Factors	Risks	Mitigations
	<p>and sustainability.</p> <ul style="list-style-type: none"> ▪ Reduce the dependency on automobiles and imported fossil fuels. ▪ Demonstrate enhanced economic growth and development. ▪ Determine effective station locations have been determined. ▪ Support appropriate technologies/vehicles by stakeholders. ▪ Maximize local efforts to plan, design, and implement infill development in station areas to capitalize on the presence of high-capacity passenger transport. ▪ Improve mobility and access by siting stations in existing land use development nodes. ▪ Steadily strengthen the ridership in 20-50 year timeframe from incremental layering of development in station areas. 	<ul style="list-style-type: none"> ▪ Station location becomes political and does not maximize economic development or ridership potential and mobility. ▪ People do not use the system because it is not convenient. ▪ Vehicle technology becomes political. 	
<p>Develop an Effective Project Funding and Financial Plan</p>	<ul style="list-style-type: none"> ▪ Project benefits are sufficient to develop state, regional, and local support for funding. ▪ Local funding sources are strong enough to qualify CDOT for federal funding. ▪ Federal funding agencies are convinced that the project sponsor (assumed to be CDOT) has the technical capacity and capability to implement a major HST program. 	<ul style="list-style-type: none"> ▪ Lack of political support for generating local funding or, local funding is simply not available. ▪ Project benefits are not sufficient. ▪ Project does not demonstrate intercity passenger rail service operating above 79 mph. ▪ Institutional agreements are not fulfilled. ▪ Program technical capacity and capability (TCC) are not sufficient to generate federal confidence in the program. 	<ul style="list-style-type: none"> ▪ Configure the project concepts to maximize public benefits. ▪ Public support for local funding is obtained due to demonstrated positive benefit/cost ratios for both capital and operating costs. ▪ Obtain institutional agreements with affected railroads. ▪ CDOT demonstrates the TCC to implement the HST program with both the depth and breadth of support from qualified agency staff.

EXHIBIT 2-3: GOALS, CRITICAL SUCCESS FACTORS, RISKS, AND MITIGATIONS

Goal	Critical Success Factors	Risks	Mitigations
Incorporate HST Planning into CDOT and other Public Transportation Plans	<ul style="list-style-type: none"> ▪ CDOT and other public transportation plans take into account future HST corridors and consider the feasibility of HST along with other transportation modes. ▪ HST planning becomes integrated with CDOT and other transportation and land use development plans. 	<ul style="list-style-type: none"> ▪ During the development of HST, logical alignments and corridors are jeopardized by ongoing development and construction of highway and other projects. 	<ul style="list-style-type: none"> ▪ Communication of HST corridors and identification of projects negatively impacting them, and either postponement of the threatening projects until HST corridors are ultimately determined, or design modifications to preserve HST future corridor utility. ▪ Have effective plans and processes to deal with risks as they surface and before they become overwhelming and threatening to the overall HST program.
Where Corridors Involve Private Freight Railroads, the Present and Future Growth of Freight Rail Capacity, Along With Freight Customer Access and the Ability of Freight Railroads to Meet their Common Carrier Obligations, is Preserved and, Where Possible, Enhanced	<ul style="list-style-type: none"> ▪ Open communication is maintained. ▪ Statewide economic development outlook is robust for freight carriers. 	<ul style="list-style-type: none"> ▪ Customers currently dependent on freight rail change to transporting freight on highways, causing more congestion and damage to state bridges and highways. ▪ Future employers requiring freight rail transportation must locate elsewhere. ▪ Either HST developer or freight railroads are branded “overreaching” in efforts to protect their primary business interests. 	<ul style="list-style-type: none"> ▪ Negotiations involving key stakeholders, particularly private business interests, minimize public disclosure which undermines propriety business knowledge and competitive business advantages.

This page intentionally left blank.

Section 3: Evaluation Process

3.1 Overview

As shown on **Exhibit 3-1**, the study approach for the ICS involves three levels of increasingly detailed evaluation, as explained in this section. At Level 4, a Preferred Alternative is recommended for public comment. After the receipt of public comments, the Preferred Alternative is refined, and the recommendation is finalized at Level 5.

EXHIBIT 3-1: ALTERNATIVES EVALUATION PROCESS

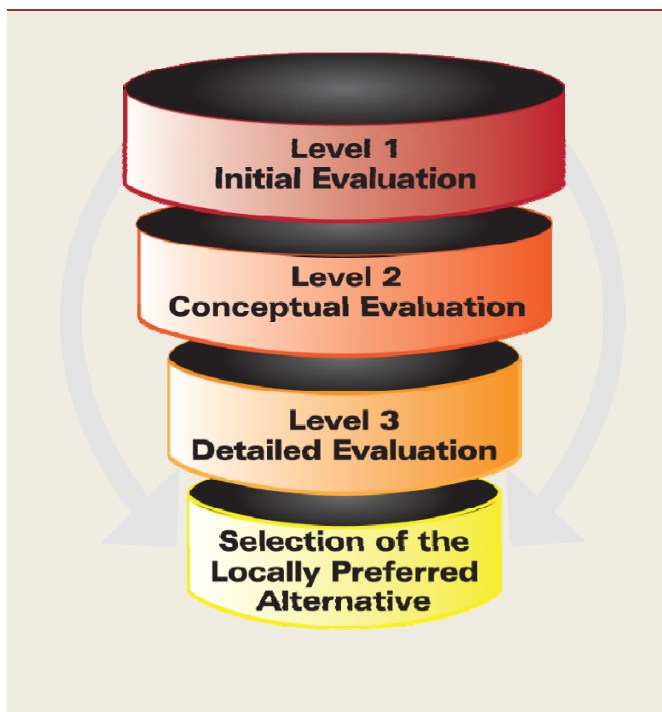

The work of each level of evaluation culminates in a milestone. The results of each milestone are presented first to the PLT, consisting of all local governments within the ICS study area. Comments are received and changes are made before the recommendations are presented to the public in four open houses, one in each city/region: Fort Collins/North Front Range, Denver, Colorado Springs/Pikes Peak, and Pueblo. Public comments are recorded and incorporated before starting the activities of the subsequent milestone. At each step, the study team gains endorsement on the relevant milestone products.

3.1.1 Key Milestones

The milestones for each level of evaluation are as follows:

- Milestone 1 – Level 1 (Initial) Evaluation:** The first step in the Level 1 Evaluation was to prepare a draft Purpose and Need Statement, evaluation criteria, and twelve initial HST scenarios. Using qualitative criteria covering Purpose and Need, Transportation and Mobility Benefits, Other Public Benefits, and Engineering Feasibility, the Level 1 Evaluation evaluated the advantages and disadvantages of possible segments and initial full scenarios for an HST system.

If a segment or a scenario was generally defined as having impacts or costs deemed to be too high for implementation, it was set aside. The results were presented at public open houses as described in Section 8, Public Process. The degree of public support for each decision was documented and influenced the scenarios to be modeled in the Level 2 Evaluation.

- Milestone 2 – Level 2 (Conceptual) Evaluation:** The Level 2 Evaluation built upon the technical analysis and public input from the Level 1 Evaluation. This level of evaluation involved a more quantitative assessment of the ridership, cost, and environmental consequences of each of the scenarios. For example, the alignment for each scenario was engineered to a level needed to document general right-of-way requirements, alignment, and curvature to estimate train travel speeds, environmental and community impacts, and probable capital costs. Ridership numbers and fare box revenues were also calculated to prepare initial benefit-to-cost relationships. The intent of the Level 2 Evaluation was to reduce the number of HST scenarios to three or four for more detailed analysis at Level 3.

The Level 2 results allow the PLT and the public to be better informed on the tradeoffs associated with each scenario. For example, are the high community impacts and capital costs predicted for the urban alignments worth the

increase in ridership compared to possible lower ridership on routes that travel around highly developed areas? Or, it may be found that the higher travel speeds allowed with the routing through less densely developed areas may actually increase ridership. The answers to these types of questions are key to the Level 2 Evaluation.

- **Milestone 3 – Level 3 (Detailed) Evaluation:** In the Level 3 Evaluation process, the remaining scenarios are refined to improve their performance, which is defined as increasing ridership, reducing costs, and mitigating environmental impacts. The refined project concepts also allow more accurate **estimates of community impacts and capital and operating costs**. In turn, this information improves the certainty of the benefit-to-cost relationships of the final or recommended HST scenarios.
- **Milestone 4 – Selection and Refinement of the Locally Preferred Alternative:** Following the Level 3 Evaluation, the best-performing scenarios are presented to the PLT and the public to determine the preferred HST scenario for Colorado. Comments from the PLT and the public are incorporated and the report is finalized. The recommended alternative is now referred to as the Locally Preferred Alternative (LPA).

3.2 Evaluation Criteria

The evaluation criteria for the ICS are presented in **Exhibit 3-2** (Level 1) and **Exhibit 3-3** (Levels 2 and 3). The Level 1 Evaluation criteria were presented at two PLT meetings and at four public open houses. It is anticipated that the Level 2 and Level 3 criteria may be refined further as they are presented to the PLT and public, as the scenarios move through Level 2 and Level 3 Evaluation.

The Level 2 and Level 3 criteria are largely based on *DOT FRA High Speed Intercity Passenger Rail Program Federal Register/Vol. 75, No 126/July 1, 2010/Notices* (USDOT, 2010).

EXHIBIT 3-2: LEVEL 1 EVALUATION CRITERIA

Criteria	Measure
Public Benefits	
<ul style="list-style-type: none"> ▪ Fulfills the Purpose and Need Statement 	Yes or No
<ul style="list-style-type: none"> ▪ Public Support 	Based on public workshop comments
<ul style="list-style-type: none"> ▪ Transportation and Mobility <p>One-Seat Ride:</p> <ul style="list-style-type: none"> • Mountains • Denver International Airport (describe for one-seat ride) • Denver Union Station (describe for one-seat ride) 	One-seat ride: Qualitative
<p>Travel Time:</p> <ul style="list-style-type: none"> • Faster than autos outside the Denver metro area (north–south) • Faster than RTD inside the Denver metro area • Meets FRA criteria for an “emerging corridor” (90-110 mph) 	Travel time: Qualitative
<ul style="list-style-type: none"> ▪ Population Served 	Quantitative using Geographic Information System (GIS)
Other Public Benefits	
<ul style="list-style-type: none"> ▪ Potential for Community and Environmental Impact 	Narrative description of the potential for consequences on the human and ecological environment
<ul style="list-style-type: none"> ▪ Safety ▪ Rail-Rail Crossings ▪ At-Grade Crossings 	Narrative description of consequence
Engineering and Institutional Feasibility	
<ul style="list-style-type: none"> ▪ Probable High Capital Cost ▪ Length ▪ Number of New or Existing Highway/Rail Structures Affected ▪ Probable Quantity of Elevated Structure ▪ Use of Existing Infrastructure ▪ Probable High Operating Cost 	Qualitative
<ul style="list-style-type: none"> ▪ Feasibility/Constructability ▪ Tunnels ▪ Access to Denver Union Station ▪ Freight Conflicts ▪ Capacity on Existing Freight Corridor 	Narrative description of consequence for entering Denver Union Station
<ul style="list-style-type: none"> ▪ Technology ▪ Limited Choices ▪ Compatibility 	Narrative description of consequence

EXHIBIT 3-3: LEVEL 2 AND LEVEL 3 EVALUATION CRITERIA

Criteria	Measure
Public Benefits	
<ul style="list-style-type: none"> ▪ Fulfilment of Purpose and Need Statement ▪ Governance and Stakeholder Support 	Qualitative narrative Based on PLT and Public comments
<ul style="list-style-type: none"> ▪ Public Support 	Qualitative narrative
<ul style="list-style-type: none"> ▪ Agency Support 	Qualitative narrative
<ul style="list-style-type: none"> ▪ CDOT Regional Support 	Qualitative narrative
<ul style="list-style-type: none"> ▪ RTD Support 	Qualitative narrative
Transportation Benefits	
<ul style="list-style-type: none"> ▪ One seat ride: Mountains/DIA/DUS 	Quantitative – model results
<ul style="list-style-type: none"> ▪ System Ridership 	Quantitative – model results
<ul style="list-style-type: none"> ▪ Generates improvements to and integrates with existing HST and Intercity Service including direct connections with local transit systems 	Quantitative – model results
<ul style="list-style-type: none"> ▪ Generates cross-modal benefits – including favorable impacts on highway and aviation congestion 	Quantitative – model results
<ul style="list-style-type: none"> ▪ Enhancing intercity travel options 	Quantitative – model results
<ul style="list-style-type: none"> ▪ Requires standardized rolling stock, signalling, communications and power equipment 	Qualitative narrative
<ul style="list-style-type: none"> ▪ Improved freight operations and equitable railroad financial participation commensurate with benefits received 	Qualitative narrative
<ul style="list-style-type: none"> ▪ Improved commuter rail (RTD) operations and equitable financial participation commensurate with benefits received 	Qualitative narrative
<ul style="list-style-type: none"> ▪ Encourages Positive Train Control (PTC) implementation 	Qualitative narrative
<ul style="list-style-type: none"> ▪ Incorporates private investment in the financing of the project 	Qualitative narrative
<ul style="list-style-type: none"> ▪ Promotes equity of service 	Qualitative narrative
Other Public Benefits	
<ul style="list-style-type: none"> ▪ Environmental quality and energy efficiency ▪ Reduction of dependence on foreign oil, including the use of renewable resources 	Reduction in VMT
<ul style="list-style-type: none"> ▪ Employment of green building and manufacturing methods 	Potential for LEED certification
<ul style="list-style-type: none"> ▪ Reduction of key emission types 	Benefit is proportionate to the reduction in VMT.
<ul style="list-style-type: none"> ▪ Promotes livable communities, complementing local governmental efforts to promote efficient land use planning 	See “Consistency with local land use planning” below under Planning Feasibility.
Improving historic transportation facilities	Yes/No
Environmental Impact	
<ul style="list-style-type: none"> ▪ Air quality 	VMT and emission calculations
<ul style="list-style-type: none"> ▪ Noise 	Linear miles of alignments near sensitive receptors
<ul style="list-style-type: none"> ▪ Energy and congestion 	VMT and energy usage calculations ¹

¹ Btu estimates from FTA New Starts evaluation criteria [FTA, 2001]. Assume 7% trucks (22,046 Btu/mile), 93% passenger cars (6,233 Btu/mile) = 7340 Btu * VMT. Does not include emissions from rail because technology has not been selected.

EXHIBIT 3-3: LEVEL 2 AND LEVEL 3 EVALUATION CRITERIA

Criteria	Measure
<ul style="list-style-type: none"> Initial and permanent employment changes² 	<p>Number of construction jobs created (including direct and spinoff jobs) (Average per year over a 10-year construction period)</p> <p>Number of operations jobs (include direct and secondary employment)</p>
<ul style="list-style-type: none"> Land use and development effects, including TOD potential 	<p>Number of communities with land use conflicts</p> <p>Acres of ROW required</p>
<ul style="list-style-type: none"> Community Disruption 	<p>Linear miles of alignments adjacent to residences, commercial businesses, employment centers, and community facilities</p>
<ul style="list-style-type: none"> Safety 	<p>Number of new at-grade crossings</p> <p>VMT reduction</p>
<ul style="list-style-type: none"> Hazardous waste 	<p>Number of Superfund sites traversed by alignments and stations</p>
<ul style="list-style-type: none"> Historic properties 	<p>Number of National Register of Historic Places (NRHP)-listed properties potentially affected by alignments and stations</p>
<ul style="list-style-type: none"> Park and recreation facilities 	<p>Number of properties potentially affected</p> <p>Linear miles adjacent to or within parks</p>
<ul style="list-style-type: none"> Wetlands and water resources 	<p>Number of stream crossings, wetland crossings, and levee crossings</p> <p>Linear miles of streams adjacent to alignments</p>
Engineering and Institutional Feasibility	
<ul style="list-style-type: none"> Capital Costs 	Quantitative
<ul style="list-style-type: none"> Operating Costs 	Quantitative
<ul style="list-style-type: none"> Cyclic Capital Costs 	Quantitative
<ul style="list-style-type: none"> Right-of-Way Costs 	Quantitative
<ul style="list-style-type: none"> Requires Multiple Technologies 	Qualitative narrative
<ul style="list-style-type: none"> Availability of Technology 	Qualitative narrative
<ul style="list-style-type: none"> Ability to Phase 	Qualitative narrative
Planning Feasibility	
<ul style="list-style-type: none"> Consistent with the State Rail Plan 	Qualitative narrative
<ul style="list-style-type: none"> Consistency with Regional Transportation Plans 	Qualitative narrative
<ul style="list-style-type: none"> Consistent with Local Land Use Planning 	Qualitative narrative
<ul style="list-style-type: none"> General Potential for TOD 	Qualitative narrative
Benefit Cost Analysis	
<ul style="list-style-type: none"> Benefit Cost Ratio 	Ratio based on methodology in environmental methodology manual

² Construction jobs are assumed to be 50 percent of construction costs, with an average salary of \$65,000. Construction spin off jobs are calculated based on a multiplier of 2.0. Operations jobs are 50 percent of the operating costs, also at \$65,000 salary. Spinoff from operations jobs are calculated using a multiplier of 1.5.

This page intentionally left blank.

Section 4: Level 1 Evaluation

As summarized earlier, the objective of the Level 1 Evaluation was to draft a Purpose and Need (presented in Section 2), define evaluation criteria (presented in Section 3), identify candidate scenarios, and recommend the best scenario for ridership modeling in the Level 2 Evaluation.

4.1 Development of Segments and Scenarios

The development of scenarios for the HST system involved building on the work done in past studies, including use of performance criteria and incorporating FRA requirements. A three-step process was followed:

- **Step 1:** Define possible segments through the Denver metro area, where a segment is defined as a possible route between two points.
- **Step 2:** Identify possible segments to the north to Fort Collins and to the south to Colorado Springs and Pueblo.
- **Step 3:** Develop the best-performing HST scenarios using the best segments.

Note: A segment is a possible route between two points (e.g., DUS to DIA) in a smaller geography. Combinations of segments make up the HST scenarios.

Exhibit 4-1 lists the name of the segments by geographical area. The names of scenarios are shown in **Exhibit 4-2**.

4.1.1 Building on Previous Studies

The concept of HST has been addressed in CDOT’s *State Rail Plan*, the RMRA *High-Speed Rail Feasibility Study*, and the I-70 Mountain Corridor PEIS.

Several other key studies have discussed the desire to include HST as part of their future vision. These include the North I-25 EIS, the East Corridor EIS, and the RTPs developed by the four MPOs in the study area: Denver Regional Council of Governments, Pikes Peak Area Council of Governments, North Front Range Metropolitan Planning Organization, and Pueblo Area Council of Governments.

Using this information, the segments listed in **Exhibit 4-1** were defined, and the alternative scenarios listed in **Exhibit 4-2** were configured.

EXHIBIT 4-1: ICS SEGMENT NAMES BY GEOGRAPHIC AREA

Segment Names

WEST

- W-1: US 6/Gold Line/DUS
- W-2: I-70/I-76/DUS
- W-3: I-70/New Stockyard Station
- W-4: I-70/US 6/DUS

EAST

- E-1: DUS/CML/I-70/East Corridor/DIA
- E-2: DUS/CML/I-70/Pena Blvd/DIA
- E-3: New Stockyard Station/I-70/Pena Blvd/DIA
- E-4: DUS/CML/96th Avenue/DIA

NORTH/SOUTH

- NS-1: CML
- NS-2: CML and Joint Line

BELTWAY

- B-1: Northwest Quadrant
- B-2: Southwest Quadrant
- B-3: Southeast Quadrant
- B-4: Northeast Quadrant

NORTH METRO

- N-1: Railroad Alignment
- N-2: Greenfield

SOUTH METRO

- S-1: Railroad Alignment
- S-2: Greenfield

100_ICB_01.DWG

EXHIBIT 4-2: ICS SCENARIOS

Alternative Scenarios

A- SERIES: Through the Denver Metropolitan Area

- A-1: Direct Alignments through Denver
- A-2: Beltway Excluding Southwest Quadrant
- A-3: Beltway Excluding Northwest Quadrant
- A-4: Western Beltway
- A-5: Eastern Beltway
- A-6: Complete Beltway

B- AND C- SERIES: RTD as Collector /Distributor

- B-1: Denver Periphery
- B-2: Denver Periphery Excluding SE Quadrant
- B-2A: Denver Periphery Excluding NW Quadrant
- B-3: Denver Periphery Eastern Beltway
- B-4: Denver Periphery Full Beltway
- C-1: Shared Track with RTD

100_ICB_01.DWG

The ICS segments based on these previous studies are summarized in **Exhibit 4-3**.

4.1.2 Performance-Based Criteria

Each of the segments was developed using the criteria presented in Section 3. These include performance measures for fulfilling the Purpose and Need, Transportation and Mobility, Public Benefits, Engineering Feasibility, and the ability to accommodate innovative technologies.

4.1.3 FRA Requirements

FRA guidelines for route development were used to develop representative segments for HST scenarios. The FRA has produced a technical working paper, *Railroad Corridor Transportation Plans (RCTP), A Guidance Manual, Section II*, that provides practical suggestions and policy guidance to aid in selecting appropriate HST alignments. The five basic criteria are:

- Geometry (horizontal and vertical curves) that affects speed and travel time
- Capacity
- Proximity to population centers
- Proximity to intermodal sites
- Cost of improvements

4.2 Description of Level 1 Segments

4.2.1 Segment Descriptions

Segments were selected within the Denver metro area, north to Fort Collins, and south to Colorado

Springs and Pueblo. The segments were then combined to configure the scenarios described later in this section.

Outside Denver Metropolitan Area Segments

Segments outside the Denver metro area that were considered for HST during Level 1 Evaluation were grouped into four categories:

- Denver to Fort Collins (N)
- Denver to Colorado Springs and Pueblo (S)
- Denver to DIA (E)
- Denver to Eagle County Regional Airport (W)

Denver Metropolitan Area Segments

The Denver metro area is anticipated to be one of the most difficult areas in which to configure a HST alignment because of high-density urban development, lack of available public right-of-way (ROW), and the presence of bridges and other existing infrastructure. Segments through the Denver metro area that were considered for during the Level 1 Evaluation were grouped into four categories:

- I-70/C-470 to Central Denver (W)
- Central Denver to DIA (E)
- North Denver to South Denver (NS)
- Beltways around the Denver metro area (B)





EXHIBIT 4-3: ICS SUMMARY

Segment	Segment Name in ICS	Study Where Recommended
BNSF rail alignment from the end-of-line station of the future RTD North Metro Commuter Rail running north through Longmont and Loveland to Fort Collins	N-1: Railroad Alignment (Renamed the "North I-25 EIS Segment" at start of Level 2 Evaluation)	CDOT North I-25 EIS
Greenfield segment from E-470 along I-25 to Fort Collins	N-2: Greenfield (Renamed the "I-25 Segment" at start of Level 2 Evaluation)	RMRA High-Speed Rail Feasibility Study
Consolidated mainline running to DUS from the north	NS-1: CML	RMRA High-Speed Rail Feasibility Study
Joint line running south from DUS to Littleton	NS-2: CML and Joint Line	RMRA High-Speed Rail Feasibility Study
US 6 from C-470/I-70 to DUS	W-4: I-70/US 6/DUS	RMRA High-Speed Rail Feasibility Study
E-470 from DIA to I-25 north	B-4: Northeast Quadrant	RMRA High-Speed Rail Feasibility Study
BNSF rail alignment from Littleton to Pueblo	S-1: Railroad Alignment	RMRA High-Speed Rail Feasibility Study
Greenfield segment from south Denver metro area to Pueblo	S-2: Greenfield	RMRA High-Speed Rail Feasibility Study

I-70/C-470 to Central Denver Segments

A description of the segments included in each category is presented below. Four segments were defined from I-70/C-470 to Central Denver, as shown in **Exhibit 4-4**.

EXHIBIT 4-4: I-70/C-470 TO CENTRAL DENVER SEGMENTS

Segment	Configuration	Segment Description	Miles
W-1: US 6/Gold Line/ DUS		From I-70/C-470, this segment follows US 6 to Golden, then turns east on the BNSF alignment near the Coors Brewery, and follows the BNSF alignment to Ward Road where it meets up with the Gold Line rail alignment, which is parallel to DUS.	21.6
W-2: I-70/I-76/DUS		From I-70/C-470, this segment follows I-70 east to I-76 at Wadsworth Boulevard to Pecos Street, then turns south at Utah Junction through the rail yards paralleling the RTD Gold Line rail alignment to DUS.	18.5
W-3: I-70/New Stockyard Station		From I-70/C-470, this segment follows I-70 east to I-25, flies over the highway to the south of 48th Avenue, travels east and flies over the CML and RTD North Metro Commuter Rail tracks, then parallels the Rock Island Line to a new Stockyard Station adjacent to the North Metro Stockyard Station.	16.5
W-4: I-70/US 6/ DUS		From I-70/C-470, this segment follows US 6 to and over I-25 to the CML where it is carried on structure over the freight rail alignment to the existing LRT terminal station (800 feet west of DUS) at DUS. Similar to LRT travellers, connection from the station to the DUS terminal would be provided by the extension of the 16 th Street Mall shuttle.	13.3

Central Denver to DIA Segments

Four segments were defined from Central Denver to DIA, as shown in **Exhibit 4-5**.

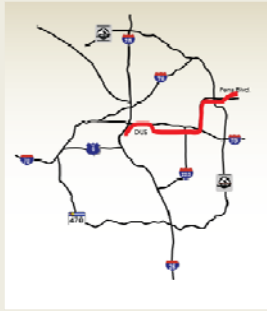
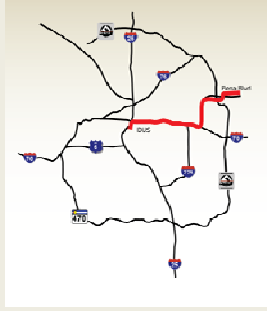
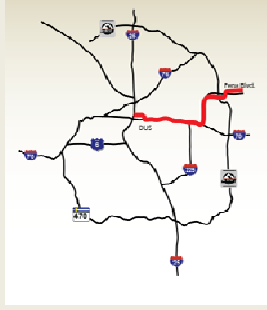
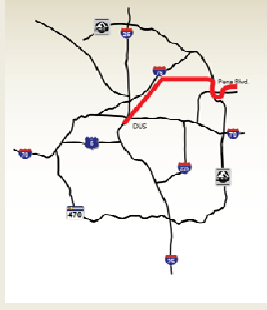
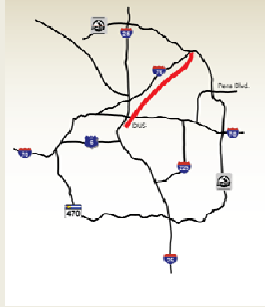

EXHIBIT 4-5: CENTRAL DENVER TO DIA SEGMENTS

Segment	Configuration	Segment Description	Miles
E-1: DUS/CML/ I-70/East Corridor/DIA		From DUS, this segment follows the CML to I-70 near Brighton Blvd, then merges with the highway alignment to Colorado Blvd where it travels south to RTD’s East Line rail alignment east to Pena Blvd, then to DIA.	23.6
E-2: DUS/CML I-70/Pena Blvd/DIA		From DUS, this segment follows the CML to I-70 near Brighton Blvd and remains on the I-70 alignment to Pena Blvd, then to DIA.	22.6
E-3: New Stockyard Station/I-70/ Pena Blvd/DIA		This segment bypasses DUS. From a new Stockyard Station, this segment is essentially the same as E-2, remaining on the I-70 alignment to Pena Blvd and DIA.	20.1
E-4: DUS/CML/96 th Avenue/DIA		From DUS, this segment follows the CML/Brush lines to 96 th Avenue where it then travels east along 96 th Avenue over E-470, then turns south to DIA.	24.3

North Denver to South Denver Segments

Two segments were defined through the Denver metro area from north to south. Both segments follow existing freight railroad alignments, as shown in **Exhibit 4-6**.

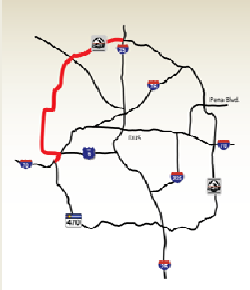



EXHIBIT 4-6: NORTH DENVER TO SOUTH DENVER

Segment	Configuration	Segment Description	Miles
NS-1: CML		From the RTD North Metro end-of-line station in Thornton, this segment travels south on the CML to DUS. It is assumed that the HST would not share track with the freight rail system due to capacity constraints.	24.7
NS-2: CML and Joint Line		From DUS, this segment travels south on the CML and Joint Line to C-470 in Littleton. It is assumed that the HST would not share track with the freight rail system due to capacity constraints.	14.5

Beltway Segments

Four segments were defined around the Denver metro area, as shown in **Exhibit 4-7**. These segments were evaluated to show the effects of bypassing the Denver metro area versus traveling directly through the urban area.

EXHIBIT 4-7: BELTWAY SEGMENTS

Segment	Configuration	Segment Description	Miles
B-1: Northwest Quadrant		From C-470/I-70, this segment follows US 6 to Colorado 93 north to greenfield (anticipated northwest quadrant highway alignment), and the Northwest Parkway to I-25.	31.0
B-2: Southwest Quadrant		From C-470/I-70, this segment follows C-470 southeast to I-25.	26.3
B-3: Southeast Quadrant		From I-25, this segment follows E-470 north to DIA.	28.0
B-4: Northeast Quadrant		From I-25, this segment follows E-470 south to DIA.	19.9

Denver to Fort Collins Segments

Two segments were defined from Denver north to Fort Collins, as shown in **Exhibit 4-8**. The N-1: Railroad Alignment segment is from the North I-25 EIS and ROD (December 2011), where it is included as a commuter rail project as one component of the preferred alternative. The N-2: Greenfield Segment (I-25 Segment) is from the RMRA *High-Speed Rail Feasibility Study* (March 2010).

EXHIBIT 4-8: DENVER TO FORT COLLINS SEGMENTS

Segment	Configuration	Segment Description	Miles
N-1: Railroad Alignment Segment		From the RTD North Metro end-of-line station at 162 nd Avenue in Thornton, this segment travels over I-25 northwest following the UPRR ROW, then travels north on the west side of County Road (CR) 7 to the south side of SH 119, then west to the BNSF rail alignment through Longmont, Loveland, and to Fort Collins. It is possible that the HST could share track with freight rail in some locations. The segment would terminate at the MAX Transit Center south of Harmony Road.	49.2
N-2: Greenfield Segment		From the Northwest Parkway/I-25 interchange, this segment travels north to Fort Collins along I-25 and ends near Harmony Road and I-25. It would not continue into Fort Collins.	45.5

Denver to Colorado Springs and Pueblo Segments

Two segments were defined from Denver south to Colorado Springs and Pueblo, as shown in **Exhibit 4-9**. Both the S-1: Railroad Alignment and S-2: Greenfield Segment are from the RMRA *High-Speed Rail Feasibility Study* (March 2010).

EXHIBIT 4-9: DENVER TO COLORADO SPRINGS AND PUEBLO SEGMENTS

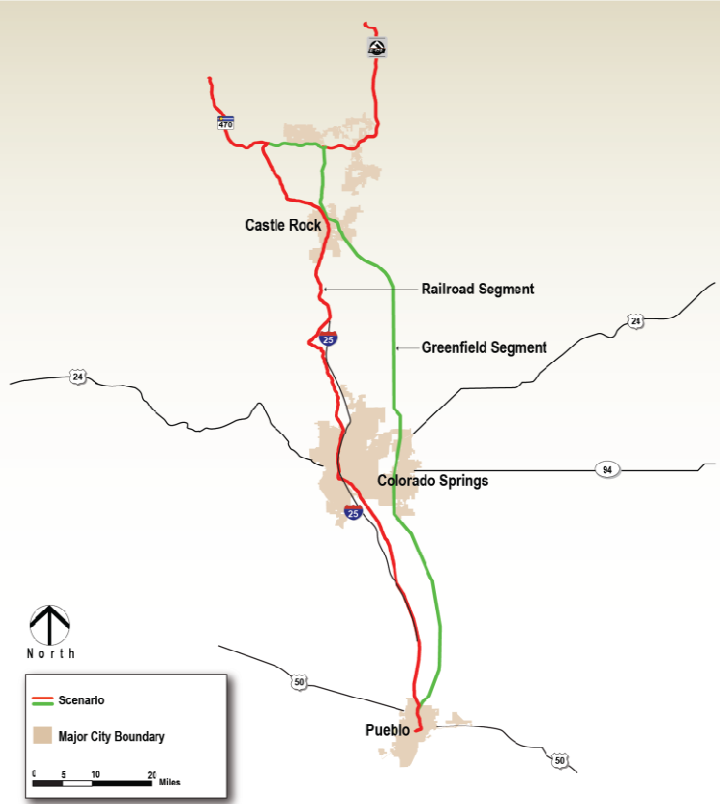
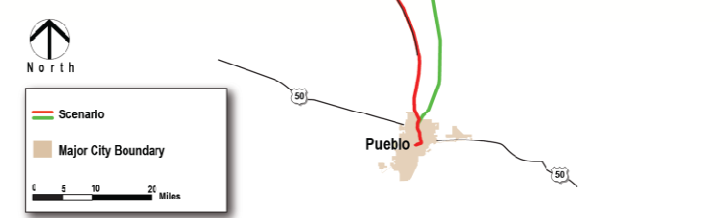
Segment	Configuration	Segment Description	Miles
<p>S-1: Railroad Alignment Segment</p>		<p>From south Denver, this segment follows the BNSF/UPRR rail alignment through Colorado Springs to Pueblo. It is assumed that the HST would not share track with the freight rail system due to capacity constraints. Because the BNSF track has fewer curves than the parallel UPRR track, fewer easements would be required to improve this segment. Therefore, from Littleton to Pueblo, the S-1 segment is anticipated to follow the BNSF rail alignment.</p>	<p>105.0</p>
<p>S-2: Greenfield Segment</p>		<p>From E-470, this segment follows I-25 to Castle Rock, then leaves the highway ROW near Santa Fe Drive in Castle Rock and travels to the southeast. The segment heads south roughly parallel and approximately 11 miles to the east of I-25. At Monument, the segment is about 9 miles east of I-25 where it continues south to the Colorado Springs Airport. From this point, the segment travels south, generally within 3 to 4 miles to the east of I-25 until it terminates in Pueblo.</p>	<p>98.5</p>

4.3 Scenario Descriptions

The ICS scenarios are packaged as follows:

- A-Series Scenarios: Through the Denver Metro Area
- B-Series and C-Series Scenarios: Around the Denver Metro Area

4.3.1 A-Series Scenarios: Through the Denver Metropolitan Area

The intent of the A-series is to run directly through the Denver metropolitan area with the shortest routes and potentially fastest travel times possible. These scenarios are all challenged by limited ROW through the urban area, which would require elevated structure or acquisition of new dedicated ROW. The scenarios were thought to be costly to construct because of the need to build on structure to minimize ROW impacts or acquire private property for ROW. The six A-series scenarios are described below, first conceptually, then on a map of the Front Range.

Scenario A-1: Direct Alignments through Denver

Scenario A-1

(also see *Exhibit 4-10* on the following page)

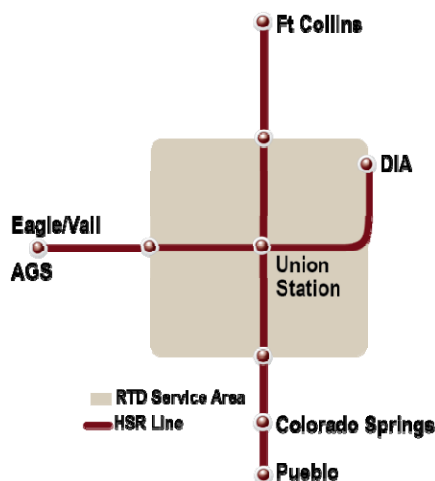

Technology

No technologies were assumed during the Level 1 Evaluation.

Segments Considered

- **East-West:** For the purposes of modeling, segment E-3: I-70 to DIA was used for the eastern segment. However, there are at least two other segments from the west to central Denver: W-3:

I-70/New Stockyard Station or W-4: I-70/US 6/DUS.

- **North-South:** Segments NS-1: CML and NS-2: CML and Joint Line, together travel through the Denver metropolitan area.
- **Outside of the Denver Metro Area:** Northern segments are N-1 or N-2, and southern segments are S-1 or S-2. This configuration is consistent for all A-, B-, and C-series HST scenarios.

Segment Combinations to be Evaluated in the Level 2 Evaluation (See Exhibit 4-10)

Using the W-3: I-70/New Stockyard Station and E-3: I-70/Pena Blvd/DIA segments, this scenario travels from west to east through Denver along I-70, over I-25 to the Rock Island Branch line, then back to I-70 and on to DIA. The north/south segments, NS-1: CML and NS-2: CML and Joint line, follow the existing Brush Line and CML from E-470 to Littleton. A new Stockyard Station would be provided adjacent to the proposed RTD North Metro Commuter Rail.

Using the W-4: I-70/US 6/DUS segment is a design option that also needs to be considered in order to evaluate the ridership impacts and community impacts of stopping or not stopping at DUS.

Outside of the Denver metro area, the HST would continue on either a railroad (N-1, S-1) or a greenfield (N-2, S-2) segment.

Length

- Denver metro area = 76 miles
- Railroad alignments outside Denver metropolitan area = 154 miles
- Greenfield segments outside Denver metropolitan area = 144 miles
- Total with railroad alignments = 230 miles
- Total with greenfield segments = 220 miles

Stations

At a minimum, this scenario would have stations at DIA, Stockyard Area (or DUS), North Metro, South Metro, West Metro, Colorado Springs, Pueblo, and Fort Collins.

Operating Strategy

This scenario would provide line-haul service with stops at DIA, North Metro, South Metro, West Metro, Colorado Springs, Pueblo, and Fort Collins. A stop at DUS is a design option that was modeled.

EXHIBIT 4-10: SCENARIO A-1: DIRECT ALIGNMENTS THROUGH DENVER

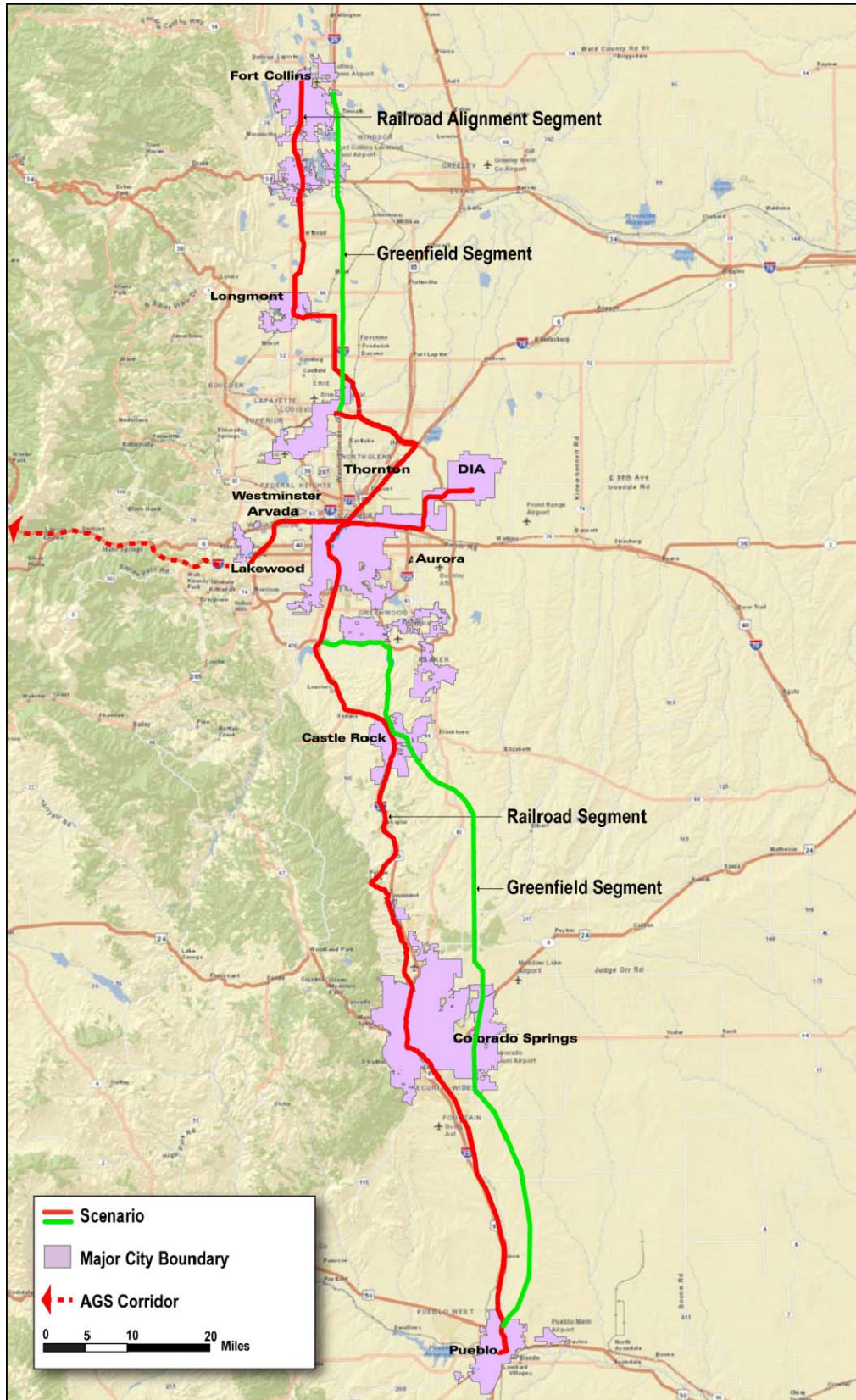

Scenario A-2: Beltway Excluding Southwest Quadrant

Scenario A-2

(also see *Exhibit 4-11* on the following page)

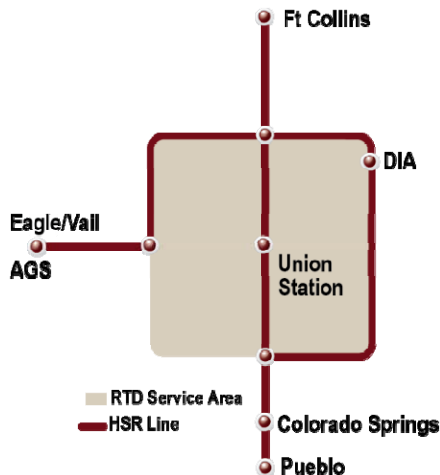

Technology

No technologies were assumed during the Level 1 Evaluation.

Segments Considered

- **East-West:** There are two segments that allow east-west travel: B-1: NW Quadrant and B-4: NE Quadrant.
- **North-South:** Segments B-3: SE Quadrant plus NS-1: CML and NS-2: CML and Joint Line allow for north-south travel.
- **Outside of the Denver Metro Area:** Northern segments are N-1 or N-2, and southern segments are S-1 and S-2. This configuration is

consistent for all A-, B-, and C-series HST scenarios.

Segment Combinations to be Evaluated in Level 2 Evaluation (See Exhibit 4-11)

This scenario travels from I-70/C-470 to a new alignment along the Northwest Corridor to the Northwest Parkway, then to E-470 and on to DIA. The north-south alignment is the same as for Scenario A-1.

Outside of the Denver metro area, the HST would continue on either a railroad (N-1, S-1) or a greenfield (N-2, S-2) segment.

Length

- Denver metro area = 119 miles
- Railroad alignments outside Denver metropolitan area = 154 miles
- Greenfield segments outside Denver metropolitan area = 144 miles
- Total with railroad alignments = 273 miles
- Total with greenfield segments = 263 miles

Stations

At a minimum, this scenario would have stations at DIA, DUS, North Metro, South Metro, West Metro, Colorado Springs, Pueblo, and Fort Collins.

Operating Strategy

This scenario would provide line-haul service with stops at the same stations referenced above.

EXHIBIT 4-11: SCENARIO A-2: BELTWAY EXCLUDING SOUTHWEST QUADRANT

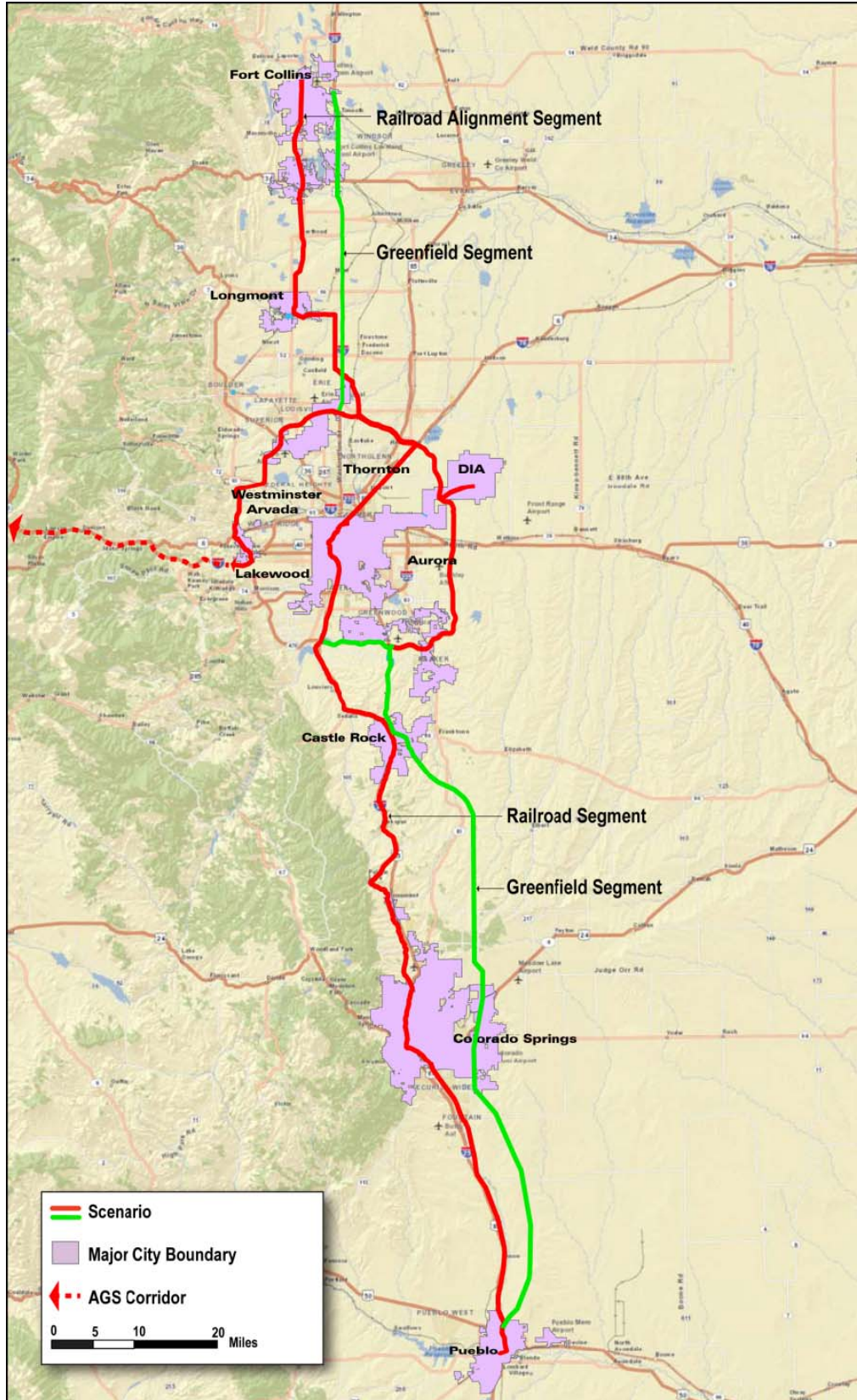

Scenario A-3: Beltway Excluding Northwest Quadrant

Scenario A-3

(also see *Exhibit 4-12* on the following page)

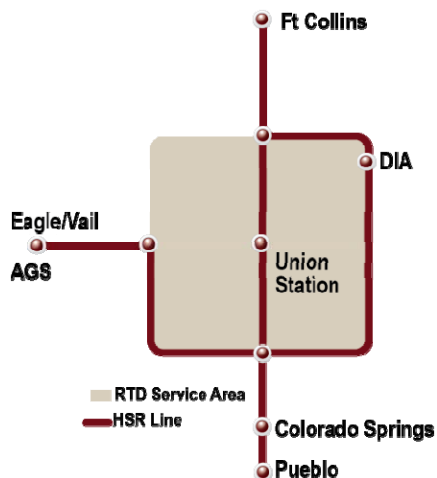

Technology

No technologies were assumed during the Level 1 Evaluation.

Segments Considered

- **East-West:** There are three segments that allow east-west travel – B-2: SW Quadrant, B-3: SE Quadrant and B-4: NE Quadrant.
- **North-South:** Segments B-3: SE Quadrant plus NS-1: CML and NS-2: CML and Joint Line allow for north-south travel.

- **Outside of the Denver Metro Area:** Northern segments are N-1 or N-2, and southern segments are S-1, S-2. This configuration is consistent for all A-, B-, and C-series HST alternative scenarios.

Segment Combinations to be Evaluated in Level 2 Evaluation (See Exhibit 4-12)

This scenario travels from I-70/C-470 south and east to E-470 and on to DIA.

Outside of the Denver metro area, the HST would continue on either a railroad (N-1, S-1) or a greenfield (N-2, S-2) segment.

Length

- Denver metro area = 114 miles
- Railroad alignments outside Denver metropolitan area = 154 miles
- Greenfield segments outside Denver metropolitan area = 144 miles
- Total with railroad alignments = 268 miles
- Total with greenfield segments = 258 miles

Stations

At a minimum, this scenario would have stations at DIA, DUS, North Metro, South Metro, West Metro, Colorado Springs, Pueblo, and Fort Collins.

Operating Strategy

This scenario would provide line-haul service with stops at the same stations referenced above.

EXHIBIT 4-12: SCENARIO A-3: BELTWAY EXCLUDING NORTHWEST QUADRANT

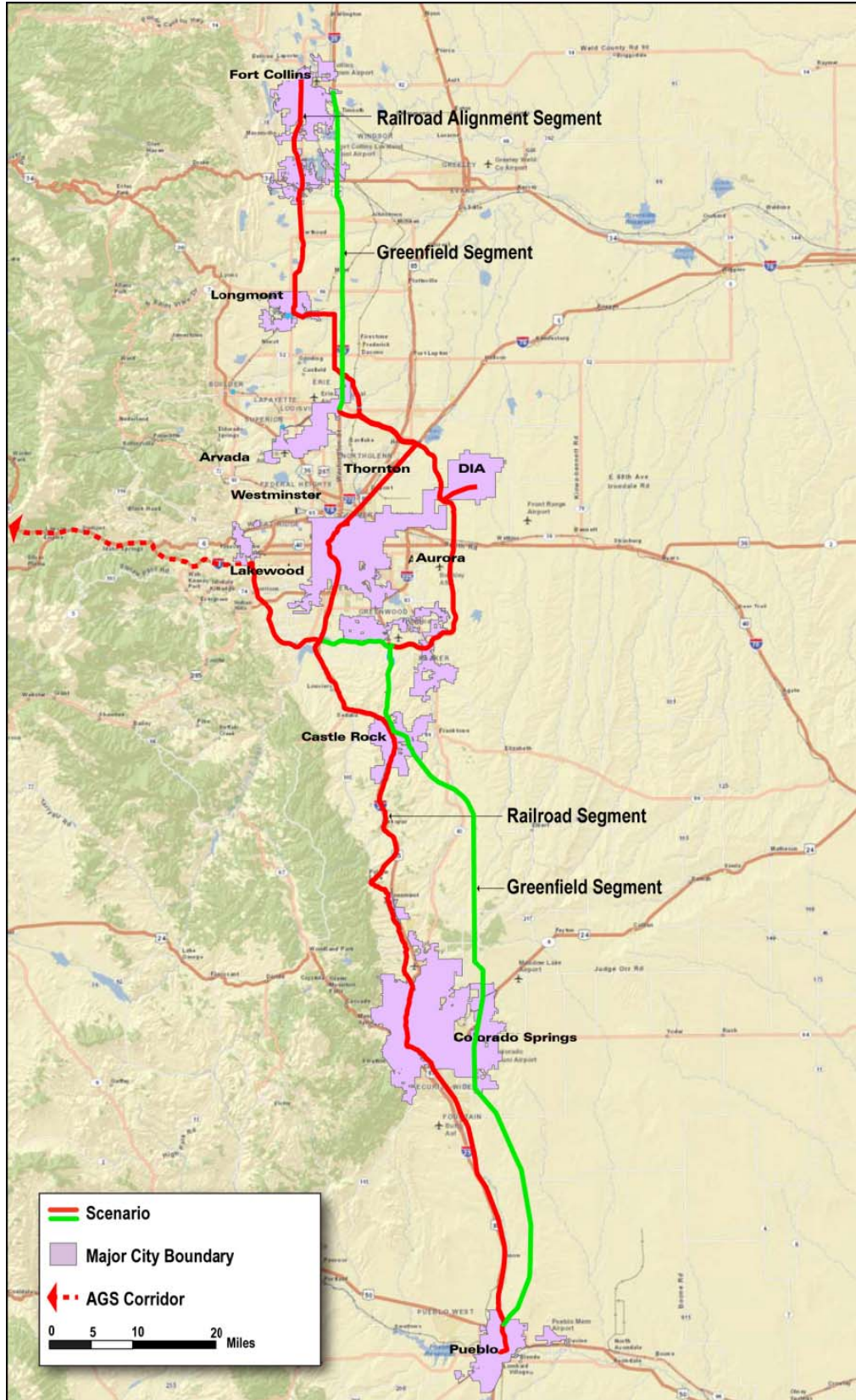

Scenario A-4: Western Beltway

Scenario A-4

(also see *Exhibit 4-13* on the following page)

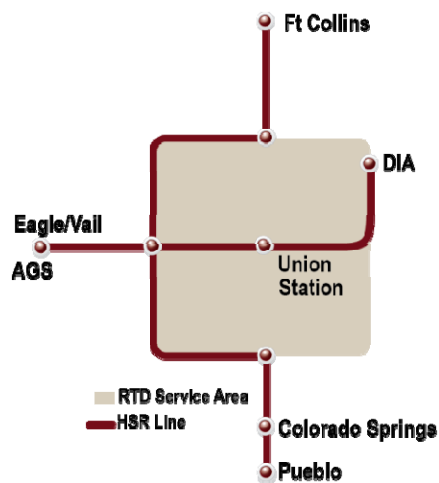

Technology

No technologies were assumed during the Level 1 Evaluation.

Segments Considered

- **East-West:** The two east-west design options for Scenario A-4 are the same as for Scenario A-1.
- **North-South:** Segments B-1: NW Quadrant and B-2: SW Quadrant allow for north-south travel.
- **Outside of the Denver Metro Area:** Northern segments are N-1 or N-2, and southern segments are S-1 or S-2. This configuration is consistent for all A-, B-, and C-series HST scenarios.

B-3: SE Quadrant (See Exhibit 4-13)

Traveling from the west, this scenario follows a new segment through the NW Quadrant to the north. Travelling south, the alignment follows C-470 to Littleton. The east-west segments are the same as described for A-1.

Outside of the Denver metro area, the HST would continue on either a railroad (N-1, S-1) or a greenfield (N-2, S-2) segment.

Length

- Denver metro area = 93 miles
- Railroad alignments outside Denver metropolitan area = 154 miles
- Greenfield segments outside Denver metropolitan area = 144 miles
- Total with railroad alignments = 247 miles
- Total with greenfield segments = 237 miles

Stations

At a minimum, this scenario would have stations at DIA, North Metro, South Metro, West Metro, Colorado Springs, Pueblo, and Fort Collins. A stop at the stockyard area or DUS is a design option.

Operating Strategy

This scenario would provide line-haul service with stops at the same stations as listed above.

EXHIBIT 4-13: SCENARIO A-4: WESTERN BELTWAY

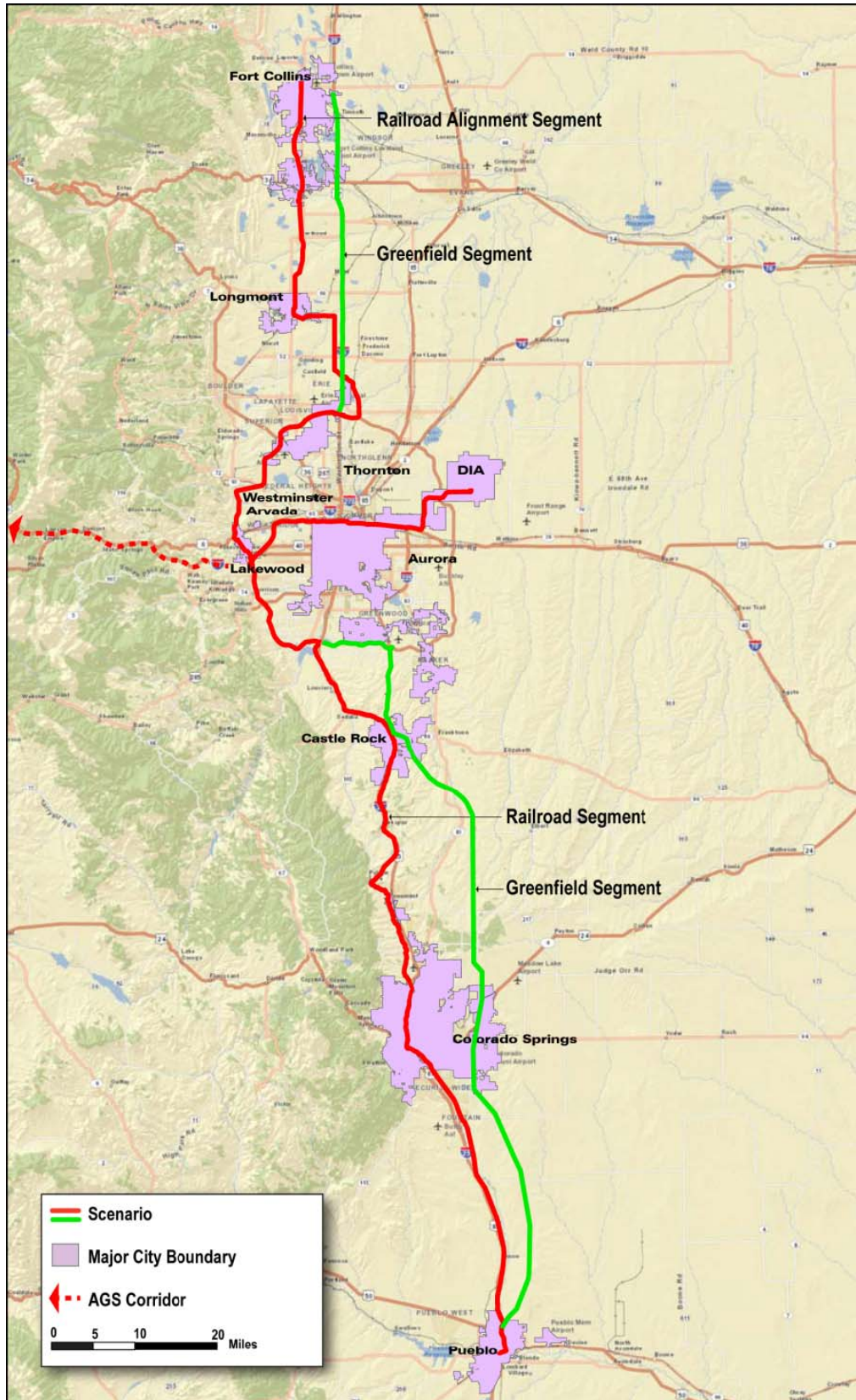

Scenario A-5: Eastern Beltway

Scenario A-5

(also see *Exhibit 4-14* on the following page)

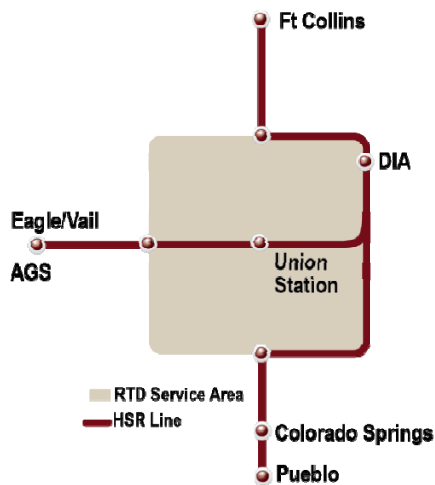

Technology

No technologies were assumed during the Level 1 Evaluation.

Segments Considered

- **East-West:** This scenario has the same two east-west options as described for Scenario A-1 and Scenario A-4.
- **North-South:** Segments B-4: NE Quadrant and B-3: SE Quadrant allow for north-south travel.
- **Outside of the Denver Metro Area:** Northern segments are N-1 or N-2, and southern segments are S-1 or S-2. This configuration is consistent for all A-, B-, and C-series HST scenarios.

Segment Combinations to be Evaluated in Level 2 Evaluation (See Exhibit 4-14)

This scenario travels north to south from I-25 along the existing E-470 alignment. The east-west segments are the same (along with the same design options) as described for Scenario A-1. A new station would be provided in the vicinity of the Stockyards.

Outside of the Denver metro area, the HST would continue on either a railroad (N-1, S-1) or a greenfield (N-2, S-2) segment.

Length

- Denver metro area = 84 miles
- Railroad alignments outside Denver metropolitan area = 154 miles
- Greenfield segments outside Denver metropolitan area = 144 miles
- Total with railroad alignments = 238 miles
- Total with greenfield segments = 228 miles

Stations

At a minimum, this scenario would have stations at DIA, DUS or stockyard area, North Metro, South Metro, West Metro, Colorado Springs, Pueblo, and Fort Collins.

Operating Strategy

This scenario would provide line-haul service with stops at the same stations as listed above.

EXHIBIT 4-14: SCENARIO A-5: EASTERN BELTWAY

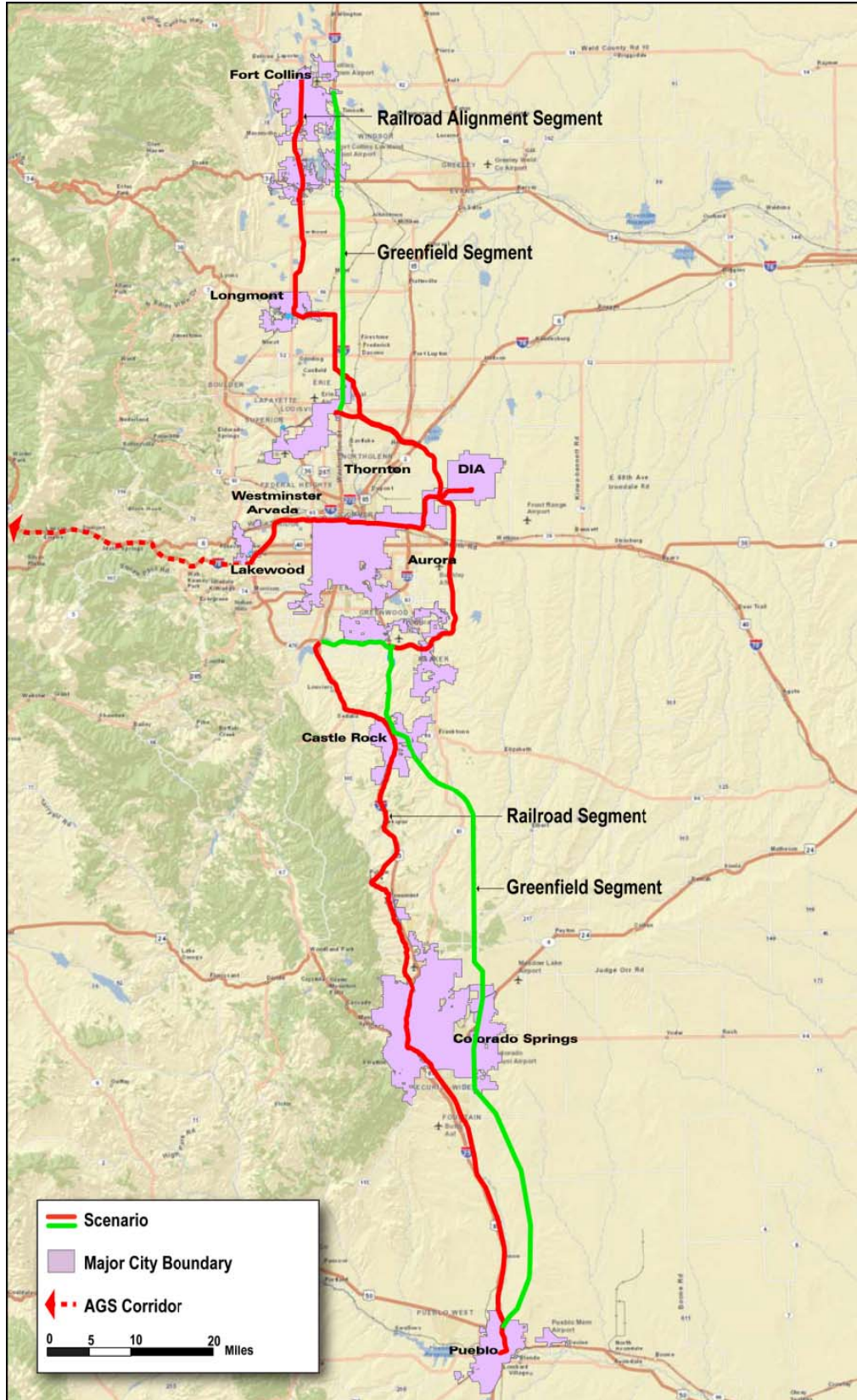

Scenario A-6: Complete Beltway

Scenario A-6

(also see *Exhibit 4-15* on the following page)

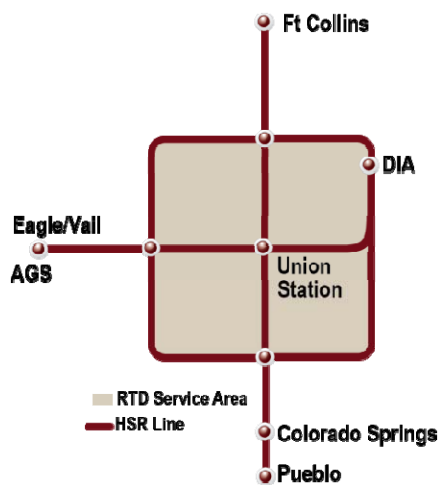

Technology

No technologies were assumed during the Level 1 Evaluation.

Segments Considered

- **East-West:** This scenario has the same two east-west design options as described for Scenario A-1, Scenario A-4, and Scenario A-5 in the east-west direction.
- **North-South:** Segments NS-1: CML, NS-2: CML and Joint Line, plus segments B-1, B-2, B-3, and B-4 allow for north-south travel.
- **Outside of the Denver Metro Area:** Northern segments are N-1 or N-2, and southern segments are S-1 or S-2. This configuration is consistent for all A-, B-, and C-series HST scenarios.

Segment Combinations to be Evaluated in Level 2 Evaluation (See Exhibit 5-15)

This scenario uses the same east-west and north-south segments as Scenario A-1 and includes beltway segments around all four quadrants of the Denver metropolitan area.

Outside of the Denver metro area, the HST would continue on either a railroad (N-1, S-1) or a greenfield (N-2, S-2) segment.

Length

- Denver metro area = 181 miles
- Railroad alignments outside Denver metropolitan area = 154 miles
- Greenfield segments outside Denver metropolitan area = 144 miles
- Total with railroad alignments = 335 miles
- Total with greenfield segments = 325 miles

Stations

At a minimum, this scenario would have stations at DIA, DUS, North Metro, South Metro, West Metro, Colorado Springs, Pueblo, and Fort Collins.

Operating Strategy

This scenario would provide line-haul service with stops at the same stations as listed above.

EXHIBIT 4-15: SCENARIO A-6: COMPLETE BELTWAY

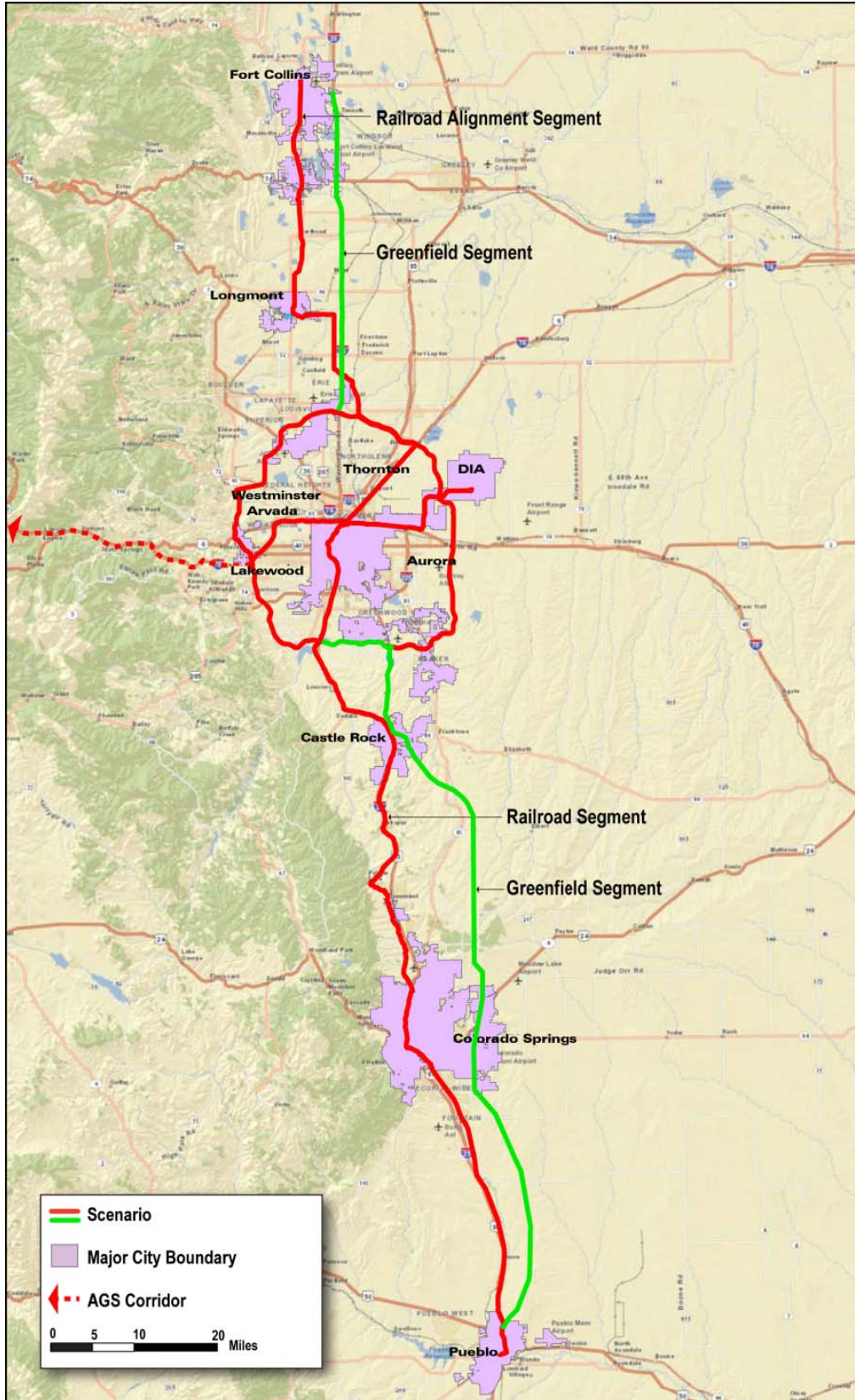

4.3.2 B-Series and C-Series Scenarios: Around the Denver Metro Area

The intent of the B- and C-series scenarios is to test the impact on HST ridership of locating the system on the periphery of the Denver metro area. These scenarios offer the advantage of fewer impacts to the urban area and lower construction costs. The six B- and C-series scenarios are described below.

Scenario B-1: Denver Periphery

Scenario B-1

(also see *Exhibit 4-16* on the following page)

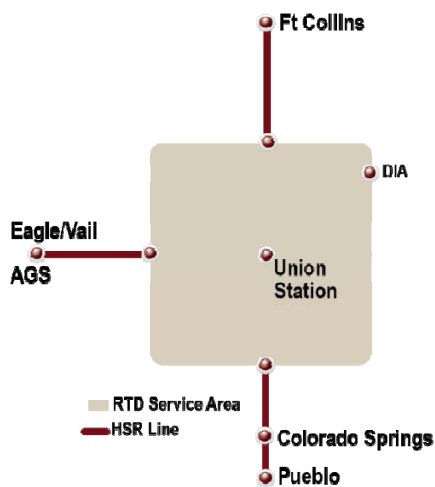

Technology

Outside the Denver metropolitan area, no technologies were assumed during the Level 1 Evaluation. Inside the RTD service area, RTD technologies would be used.

Segments Considered

- **East-West:** Within the Denver metropolitan area, HST passengers would use RTD's transit system.
- **North-South:** Within the Denver metropolitan area, HST passengers would use RTD's transit system.
- **Outside of the Denver Metro Area:** Northern segments are N-1 or N-2, and southern segments are S-1 or S-2. This configuration is consistent for all A-, B-, and C-series HST scenarios.

Segment Combinations to be Evaluated in Level 2 Evaluation (See Exhibit 4-16)

No new HST infrastructure would be constructed in the Denver metropolitan area for this scenario.

Outside of the Denver metro area, the HST would continue on either a railroad (N-1, S-1) or a greenfield (N-2, S-2) segment.

Length

- Denver metro area = 0 miles
- Railroad alignments outside Denver metropolitan area = 154 miles
- Greenfield segments outside Denver metropolitan area = 144 miles
- Total with railroad alignments = 154 miles
- Total with greenfield segments = 144 miles

Stations

At a minimum, this scenario would have stations at, North Metro, South Metro, West Metro, Colorado Springs, Pueblo, and Fort Collins.

Operating Strategy

The operating strategy is to rely on the RTD transit system to provide the connections and distribution of passengers from the HST located on the periphery to destinations within the Denver metro area. Passengers would transfer from HST to RTD at or near RTD end-of-line stations. All or nearly all trips require transfers.

EXHIBIT 4-16: SCENARIO B-1: DENVER PERIPHERY

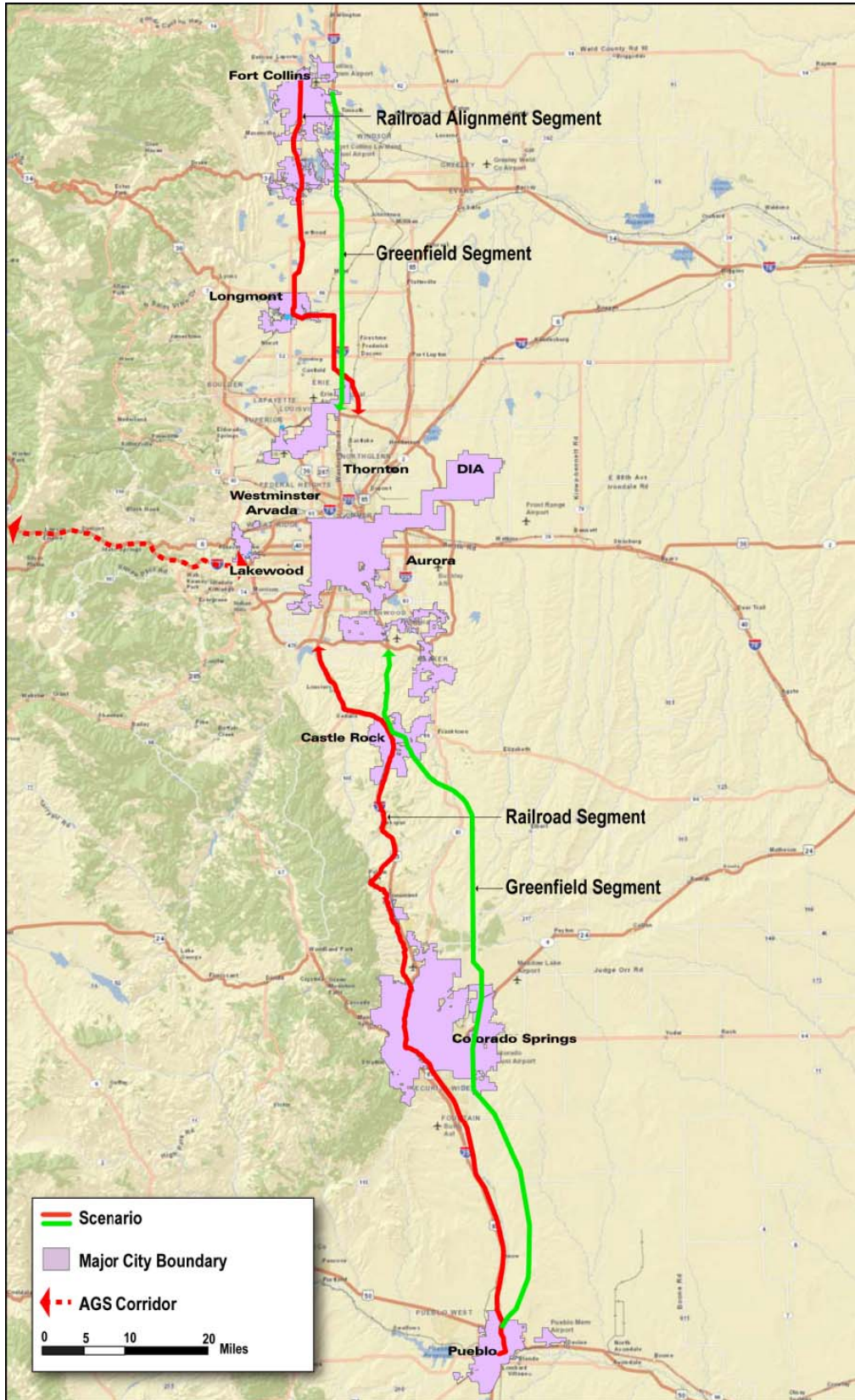

Scenario B-2: Denver Periphery Excluding Southeast Quadrant

Scenario B-2

(also see *Exhibit 4-17* on the following page)

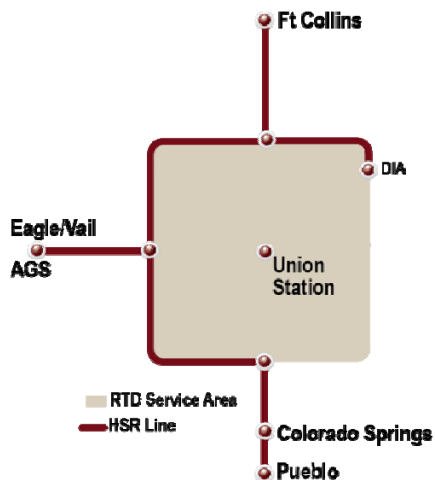

Technology

Outside the Denver metro area, no technologies were assumed during the Level 1 Evaluation. Inside the RTD service area, RTD technologies would be used.

Segments Considered

- **East-West:** Within the Denver metro area, HST passengers would use RTD's transit system plus the B-4: NE Quadrant segment to get passengers to DIA.
- **North-South:** Within the Denver metro area, HST passengers would use RTD's transit system plus the B-1: NW Quadrant and B-2: SW Quadrant segments.
- **Outside of the Denver Metro Area:** Northern segments are N-1 or N-2, and southern segments are S-1 or S-2. This configuration is consistent for all A-, B-, and C-series HST scenarios.

Segment Combinations to be Evaluated in Level 2 Evaluation (See Exhibit 4-17)

This scenario connects to the RTD system through the construction of beltway HST scenarios along C-470 from I-70 to I-25 in the southwest and on E-470 from DIA to I-25 in the northeast. A new beltway segment would be constructed from I-70 to I-25 to the northwest.

Outside of the Denver metro area, the HST would continue on either a railroad (N-1, S-1) or a greenfield (N-2, S-2) segment.

Length

- Denver metro area = 77 miles
- Railroad alignments outside Denver metropolitan area = 154 miles
- Greenfield segments outside Denver metropolitan area = 144 miles
- Total with railroad alignments = 231 miles
- Total with greenfield segments = 221 miles

Stations

At a minimum, this scenario would have stations at DIA, North Metro, South Metro, West Metro, Colorado Springs, Pueblo, and Fort Collins.

Operating Strategy

The operating strategy is to rely on RTD transit system to provide the connections and distribution of passengers from the HST located on the periphery to destinations within the Denver metro area. Many, but not all trips, require transfers. I-70 corridor to DIA can operate without transfers, as a one-seat ride.

EXHIBIT 4-17: SCENARIO B-2: DENVER PERIPHERY EXCLUDING SOUTHEAST QUADRANT

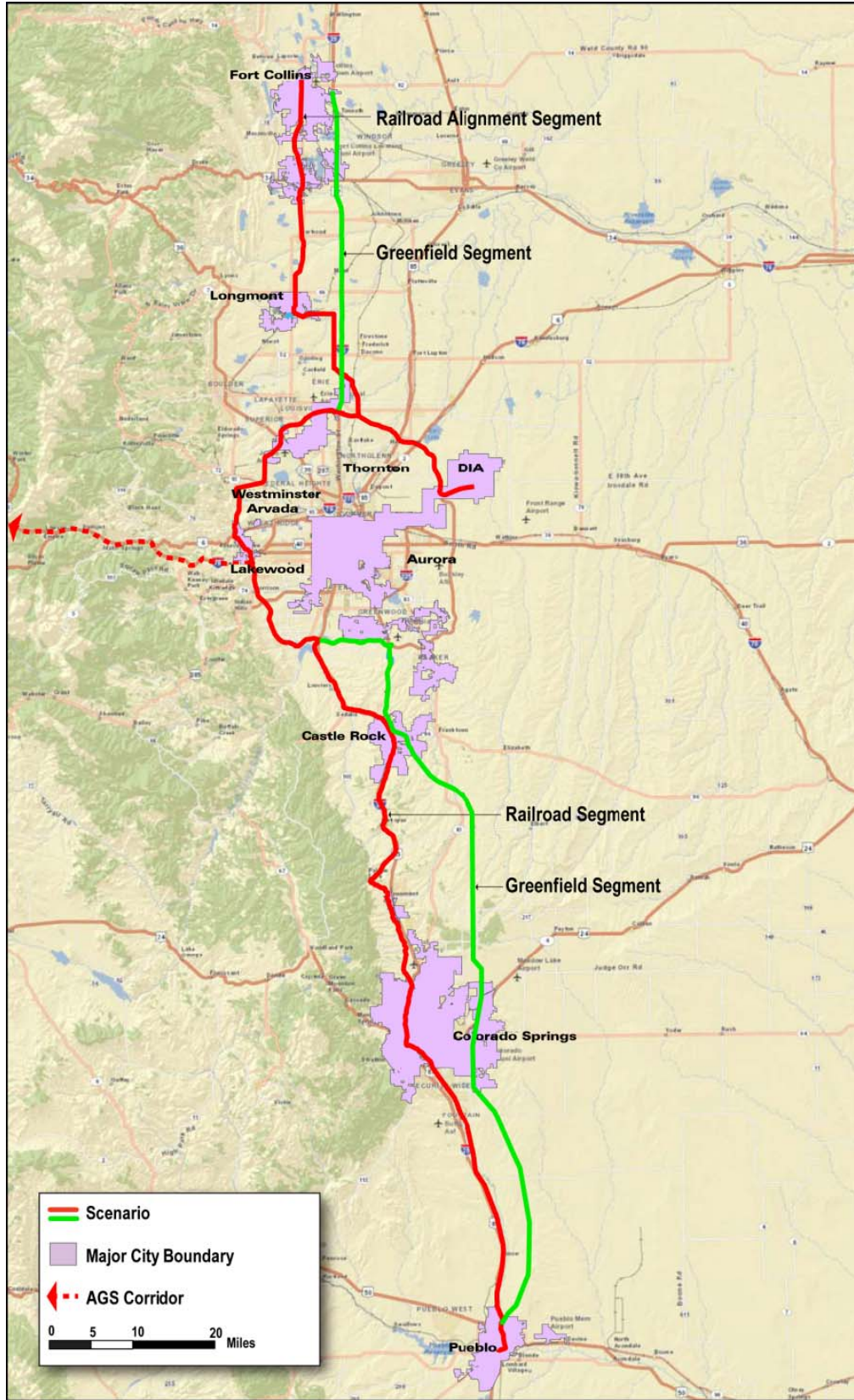

B-2A: Denver Periphery Excluding NW Quadrant

Scenario B-2A

(also see *Exhibit 4-18* on the following page)

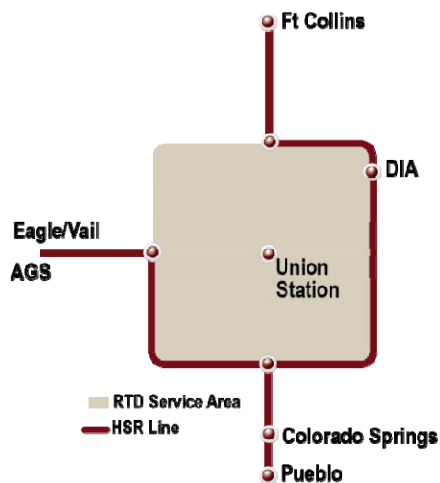

Technology

Outside of the Denver metropolitan area, no technologies were assumed during the Level 1 Evaluation. Inside the RTD service area, RTD technologies would be used.

Segments Considered

- **East-West:** Within the Denver metro area, HST passengers would use RTD's transit system plus the B-4: NE Quadrant segment.
- **North-South:** Within the Denver metro area, HST passengers would use RTD's transit system plus the B-2: SW Quadrant and B-3: SE Quadrant segments.
- **Outside of the Denver Metro Area:** Northern segments are N-1 or N-2, and southern segments are S-1 or S-2. This configuration is consistent for all A-, B-, and C-series HST scenarios.

Segment Combinations to be Evaluated in Level 2 Evaluation (See Exhibit 4-18)

This scenario connects to the RTD system through the construction of a beltway of HST track following C-470 south and east from the C-470/I-70 interchange to I-25. From this point, the HST would follow E-470 east and north to DIA, and from this point north to I-25.

Outside of the Denver metro area, the HST would continue on either a railroad (N-1, S-1) or a greenfield (N-2, S-2) segment.

Length

- Denver metro area = 74 miles
- Railroad alignments outside Denver metropolitan area = 154 miles
- Greenfield segments outside Denver metropolitan area = 144 miles
- Total with railroad alignments = 228 miles
- Total with greenfield segments = 218 miles

Stations

At a minimum, this scenario would have stations at DIA, North Metro, South Metro, West Metro, Colorado Springs, Pueblo, and Fort Collins.

Operating Strategy

The operating strategy is to rely on the RTD transit system to provide the connections and distribution of passengers from the HST located on the periphery to destinations within the Denver metro area. Many, but not all trips, require transfers. I-70 corridor to DIA can operate without transfers, as a one-seat ride.

EXHIBIT 4-18: SCENARIO B-2A: DENVER PERIPHERY EXCLUDING NW QUADRANT

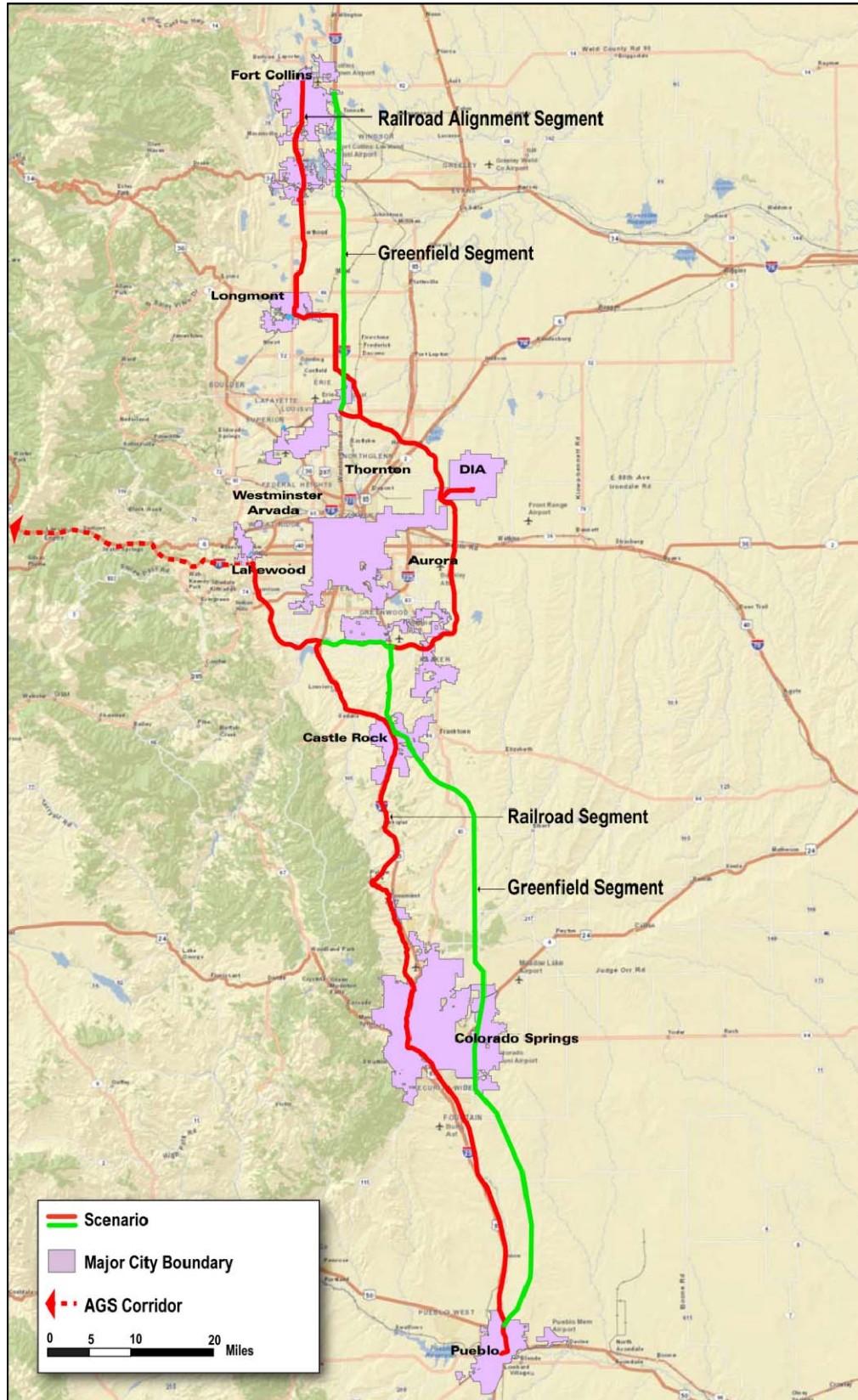

Scenario B-3: Denver Periphery Eastern Beltway

Scenario B-3

(also see *Exhibit 4-19* on the following page)

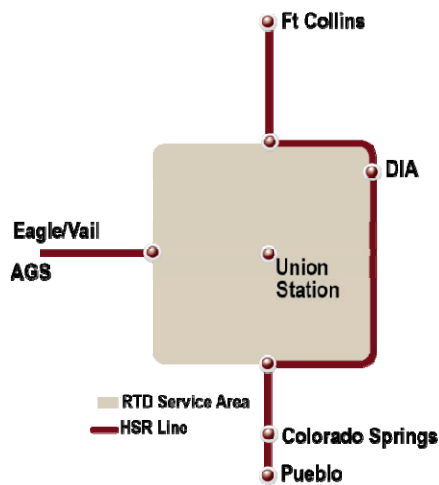

Technology

Outside of the Denver metro area, no technologies were assumed during the Level 1 Evaluation. Inside the RTD service area, RTD technologies would be used.

Segments Considered

- **East-West:** Within the Denver metropolitan area, HST passengers would use RTD's transit system plus the B-4: NE Quadrant segment.
- **North-South:** Within the Denver metropolitan area, HST passengers would use RTD's transit system plus the B-3: SE Quadrant segment.
- **Outside of the Denver Metro Area:** Northern segments are N-1 or N-2, and southern segments are S-1 or S-2. This configuration is consistent for all A-, B-, and C-series HST scenarios.

Segment Combinations to be Evaluated in Level 2 Evaluation (See Exhibit 4-19)

This scenario connects to the RTD system through the construction of HST following E-470 from I-25 east and south to DIA, then south on E-470 to I-25 south of Denver.

Outside of the Denver metro area, the HST would continue on either a railroad (N-1, S-1) or a greenfield (N-2, S-2) segment.

Length

- Denver metro area = 48 miles
- Railroad alignments outside Denver metropolitan area = 154 miles
- Greenfield segments outside Denver metropolitan area = 144 miles
- Total with railroad alignments = 202 miles
- Total with greenfield segments = 192 miles

Stations

At a minimum, this scenario would have stations at DIA, North Metro, South Metro, West Metro, Colorado Springs, Pueblo, and Fort Collins.

Operating Strategy

The operating strategy is to rely on RTD transit system to provide the connections and distribution of passengers from the HST located on the periphery to destinations within the Denver metro area. Many, but not all trips, require transfers. This configuration does not permit a one-seat ride from the I-70 mountain corridor to DIA.

EXHIBIT 4-19: SCENARIO B-3: DENVER PERIPHERY EASTERN BELTWAY

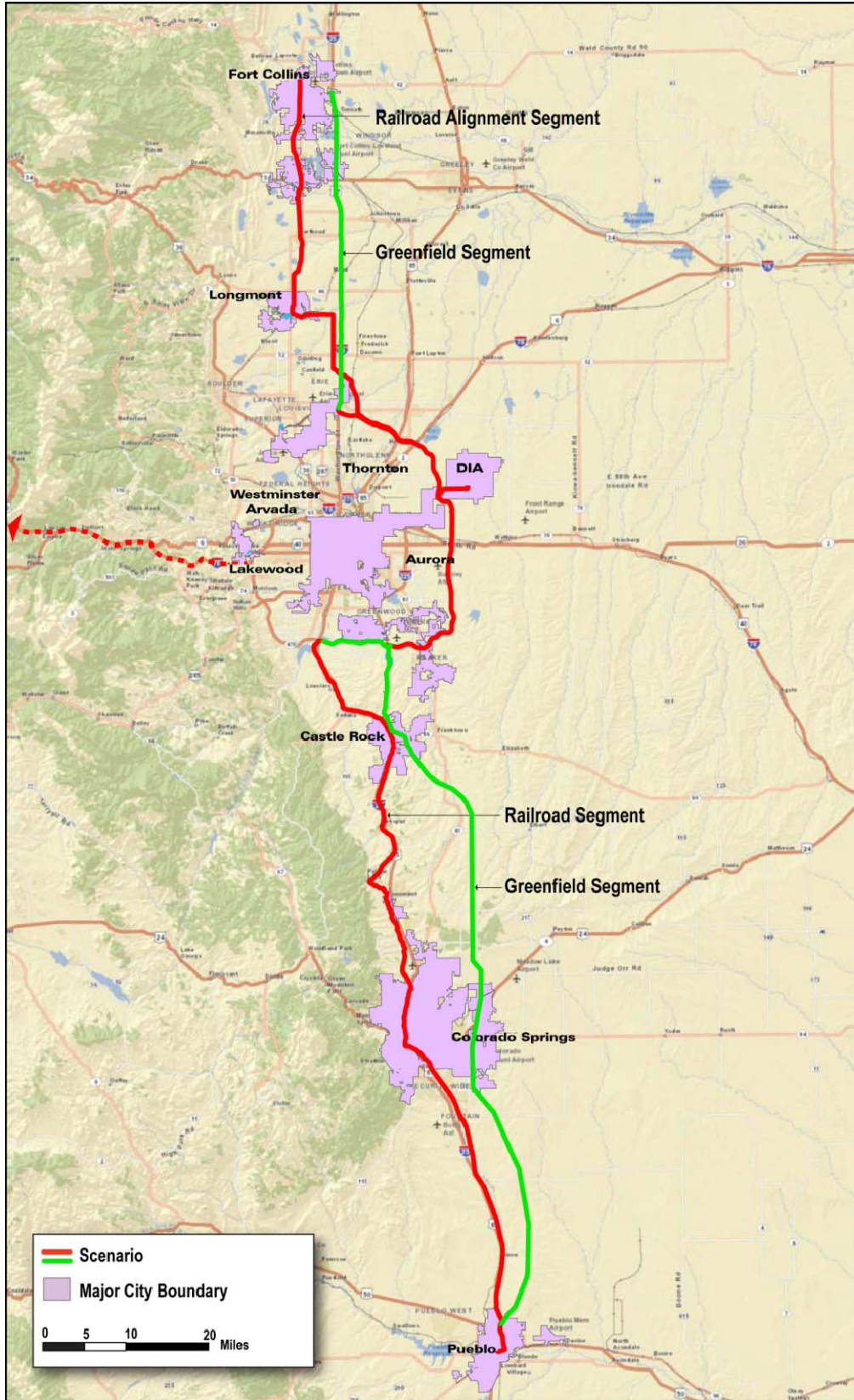

Scenario B-4: Denver Periphery Full Beltway

Scenario B-4

(also see Exhibit 4-20 on the following page)

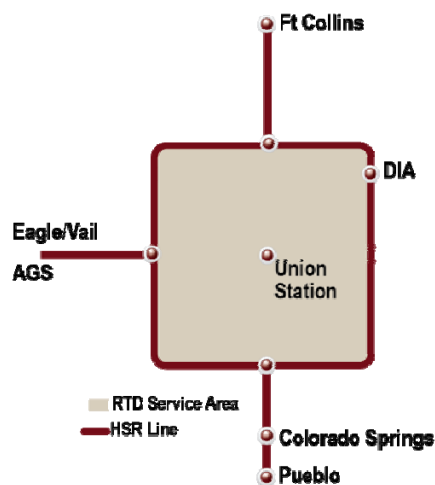

Technology

Outside of the Denver metro area, no technologies were assumed during the Level 1 Evaluation. Inside the RTD service area, RTD technologies would be used.

Segments Considered

- **East-West:** Within the Denver metro area, HST passengers would use RTD's transit system plus the B-2: SW Quadrant and B-4: NE Quadrant segments.
- **North-South:** Within the Denver metro area, HST passengers would use RTD's transit system plus the B-1: NW Quadrant, B-2: SW Quadrant, and B-3: SE Quadrant and B4: NE Quadrant.
- **Outside of the Denver Metro Area:** Northern segments are N-1 or N-2, and southern segments are S-1 or S-2. This configuration is consistent for all A-, B-, and C-series HST scenarios.

Segment Combinations to be Evaluated in Level 2 Evaluation (See Exhibit 4-20)

This scenario connects to the RTD system through the construction of HST segments around the entire Denver metropolitan area using the E-470 and C-470 alignments. A new beltway segment would be constructed from I-70 to I-25 in the northwest quadrant.

Outside of the Denver metro area, the HST would continue on either a railroad (N-1, S-1) or a greenfield (N-2, S-2) segment.

Length

- Denver metro area = 105 miles
- Railroad alignments outside Denver metropolitan area = 154 miles
- Greenfield segments outside Denver metropolitan area = 144 miles
- Total with railroad alignments = 259 miles
- Total with greenfield segments = 249 miles

Stations

At a minimum, this scenario would have stations at DIA, North Metro, South Metro, West Metro, Colorado Springs, Pueblo, and Fort Collins.

Operating Strategy

The operating strategy is to rely on RTD transit system to provide the connections and distribution of passengers from the HST located on the periphery to destinations within the Denver metro area. Many, but not all trips, require transfers. I-70 corridor to DIA can operate without transfers, as a one-seat ride.

EXHIBIT 4-20: SCENARIO B-4: DENVER PERIPHERY FULL BELTWAY

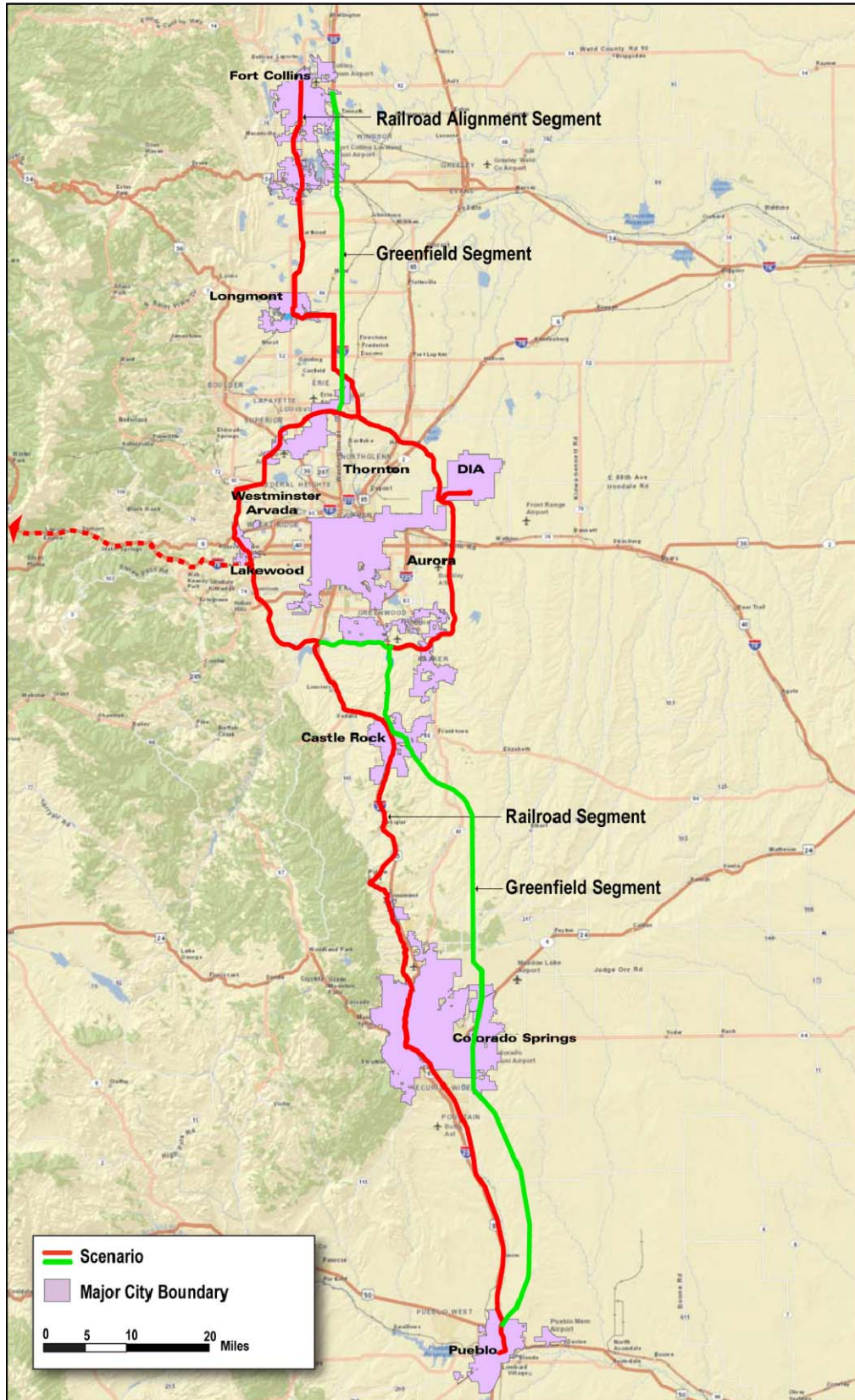

Scenario C-1: Shared Track with RTD

Scenario C-1

(also see *Exhibit 4-21* on the following page)

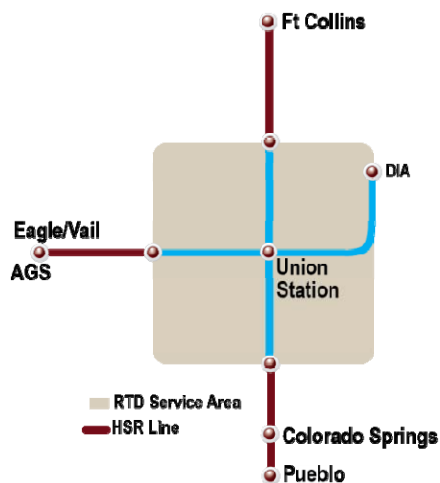

Technology

This scenario would require FRA-compliant technologies.

Segments Considered

East-West: Shared use of RTD's EAGLE Rail tracks from DIA to Ward Road in Arvada.

North-South: Shared use of RTD's future North Metro Commuter Rail tracks to DUS. HST could not share RTD's Southeast and Southwest Corridor light rail tracks due to the differences in technology.

Outside of the Denver Metro Area: Northern segments are N-1 or N-2, and southern segments are S-1 or S-2. This configuration is consistent for all A-, B-, and C-series HST scenarios.

Segment Combinations to be Evaluated in Level 2 Evaluation (See Exhibit 4-21)

This scenario assumes that HST would use an operating window on the existing East Line and Gold Line Commuter Rail projects and the future North Metro Commuter Rail project. Because RTD operates light rail vehicles on both the southwest and southeast corridors, FRA-compliant technology could not be used. Some improvements to signal systems might be required to make this alternative scenario function.

Outside of the Denver metro area, the HST would continue on either a railroad (N-1, S-1) or a greenfield (N-2, S-2) segment.

Length

- Denver metropolitan area = 0 miles
- Railroad alignments outside Denver metro area = 154 miles
- Greenfield segments outside Denver metropolitan area = 144 miles
- Total with railroad alignments = 154 miles
- Total with greenfield segments = 144 miles

Stations

At a minimum, this scenario would have stations at North Metro, South Metro, West Metro, Colorado Springs, Pueblo, and Fort Collins.

Operating Strategy

The operating strategy is for HST to share track with RTD's East Rail, Gold Line, and North Metro Commuter Rail projects. This would require negotiation of an operating window with RTD.

HST could not operate on either the Southeast or Southwest Corridor tracks, as described earlier.

EXHIBIT 4-21: SCENARIO C-1: SHARED TRACK WITH RTD

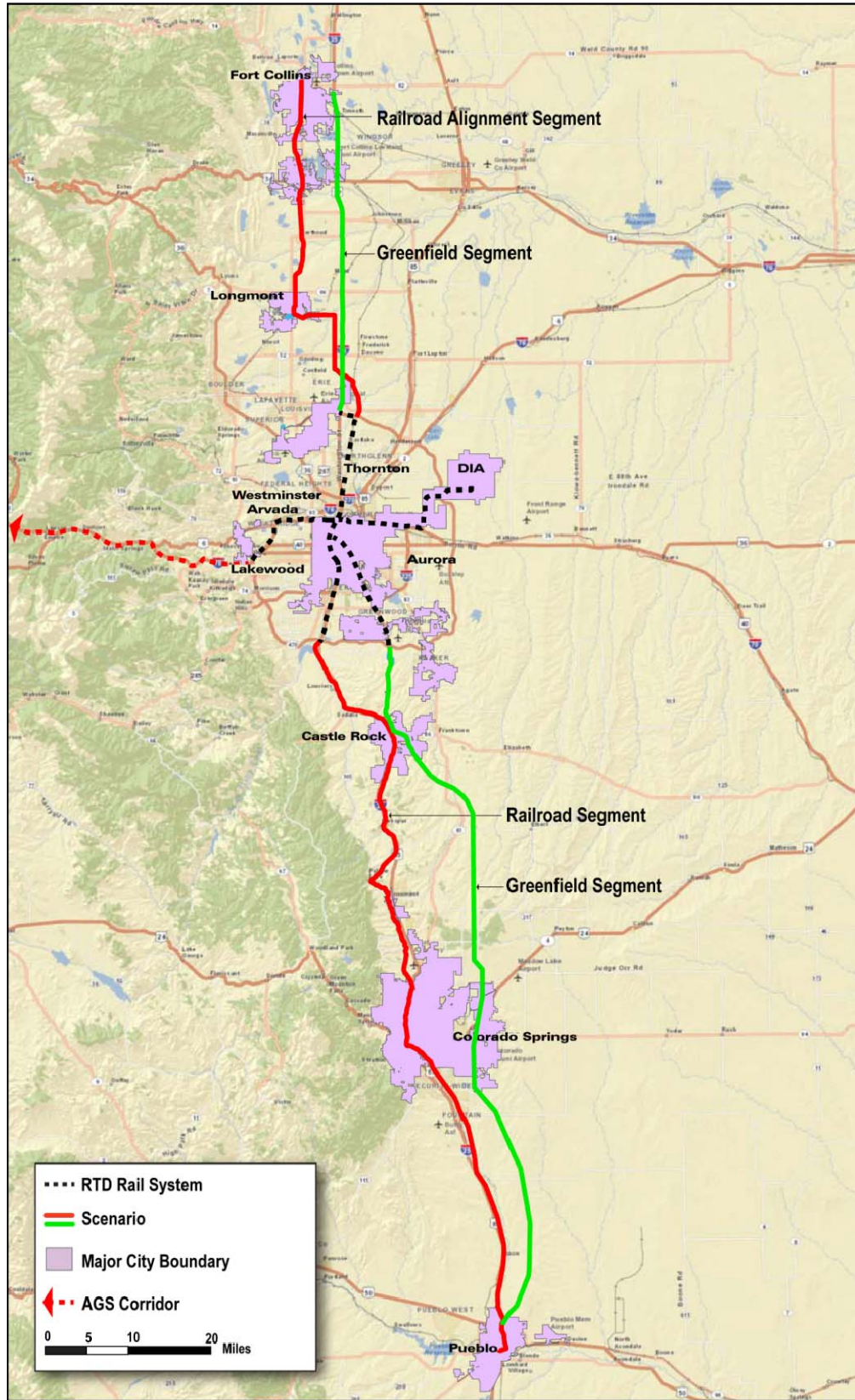

4.4 Evaluation of Level 1 Segments and Scenarios

This section discusses how the individual segments and the composite HST scenarios were evaluated and the results of this evaluation. The Level 1 Evaluation concludes with several of the segments being placed aside from further consideration due to anticipated poor efficiency for HST and/or high community impacts. However, some of the segments that are anticipated to perform effectively for HST also can be expected to cause high community impacts, require extensive ROW acquisition, and be costly to construct. Many of the segments that fall into this latter category were retained for Level 2 ridership modeling studies to provide a baseline from which to judge segments that have fewer impacts but are likely to generate lower HST ridership. Detailed cost estimates in the Level 2 Evaluation helped determine the disposition of these segments.

Six evaluation criteria were developed to provide a qualitative review of the Level 1 segments and scenarios. The intent was to evaluate the segments of a possible scenario such as four possible routings from the C-470/I-70 interchange in Jefferson County to Central Denver, then combine the best performing segments into scenarios.

In Level 1 Evaluation, the majority of the measures were qualitative and based on Google Earth evaluation, conclusions from past studies, and wind shield surveys to better understand the physical challenges facing each segment. Comparisons or trade-offs between segments were also evaluated. Both the segments and the resulting scenarios were evaluated using the same six general criteria, which included:

- **Fulfillment of the Purpose and Need** – Each segment was evaluated for its ability to meet the general intent of the Purpose and Need of the study. Because no quantitative data exists for costs, impacts, or ridership, only general conclusions could be drawn. For example, those segments that follow railroad alignments generally do not support the speed characteristics of HST and thus scored lower than the straighter, faster greenfield segments.
- **Transportation and Mobility** – This criterion included qualitative measures, such as the opportunity for a “one-seat” ride, which has been articulated as a high priority for the I-70 mountain corridor stakeholders. Other measures included travel time measured as faster than RTD inside the Denver metropolitan area and faster than an automobile outside of cities; ability to meet FRA’s criteria for Emerging HST (90 to 110 mph); and population served. This latter measure proved less valuable because all of the greenfield alternatives were assumed to include the same station locations. Conversely, the railroad alignments typically are anticipated to operate slower, run through urban areas and have been specified to include more stops based on the recommendations of earlier studies.
- **Other Public Benefits** – This criterion included the potential for environmental and community impacts based on general population density or the known presence of important environmental features. Public safety was measured based on the number of at-grade crossings in a segment.
- **Engineering Feasibility** – This criterion included the judgment call that a segment represented the potential for high construction costs due to the quantity of elevated structure, general lack of ROW, and the need for interface with the freight railroads and difficult topography. The potential for operational conflicts with the freight railroads also was considered.
- **Ability to Accommodate a Range of Technologies** – The I-70 mountain corridor stakeholders are concerned that the availability of technologies not be limited to those that are FRA compliant. Because non-FRA compliant technologies may be lighter and thus more accommodating to the requirements of the mountain environment. The ability to have a HST technology that is common to a state-wide system is also considered important.
- **Degree of Community Support** – This criterion is both a quantitative count of public comments and a qualitative assessment of public opinion based on results of the PLT and public open houses conducted during Level 1 Evaluation. The different technologies and scenarios result in varying impacts on community resources and residences and, therefore, varying levels of community-based support for implementation. Section 6 summarizes the input received at the public open houses held in Denver, Fort Collins, Colorado Springs, and Pueblo.

4.5 Evaluation of Technologies

At this point in the study, no transit technologies have been eliminated. The intent of the ICS is to find scenarios that allow a full range of technologies, with a minimum speed of 90 to 100 mph possible on some portions of the alignment. The lower speed capabilities would be characteristic of the segments that follow railroad alignments. The greenfield segments would be configured for speeds up to and even beyond 200 mph.

The I-70 mountain corridor stakeholders have a strong preference for AGS technologies that can be elevated, travel at least as fast as an automobile, are quiet, and are possibly lighter than conventional train-sets. The scenarios have been conceived to allow these technologies in most instances. Segments within the railroad corridors must use FRA-compliant technologies, ruling out equipment that does not meet these criteria. All of the greenfield segments would allow both FRA-compliant as well as non-compliant technologies. The categories of technologies brought into the Level 2 Evaluation are listed in **Exhibit 4-22**.

4.6 Level 1 Segments

As described earlier, the individual segments are the building blocks for the HST scenarios. The intent at the Level 1 Evaluation is to identify the best-performing segments for incorporation into the HST scenarios. **Exhibit 4-23** presents the summary analysis of the 18 segments considered in the Level 1 Evaluation. Of the total, it was recommended that five segments be placed aside:

- W-1: US 6/Gold Line/DUS
- W-2: I-70/I-76/DUS
- B-1: Northwest Quadrant
- E-1 DUS/CML/I-70/East Corridor/DIA
- S-2: Greenfield

Exhibit 4-23 summarizes the reasons that the above segments were set aside. More detailed information can be found in Appendix A, Level 1 and 2 Evaluation Matrices. Segments that were carried forward were considered to sufficiently fulfill the evaluation criteria and were advanced to the Level 2 Evaluation.

EXHIBIT 4-22: TECHNOLOGY CATEGORIES





Technology	Description
	Steel wheel on steel rail, FRA-compliant, diesel powered equipment, limited in speed to 110 mph, with railcar tilting capability around curves. Suitable for use on existing rail corridors, including with shared track.
	Steel wheel on steel rail, FRA-compliant, electrified equipment, with tilting capability. Suitable for use on dedicated track at speeds from 150 to 220 mph in new, fully grade-separated corridors. In urban conditions where ROW is constrained, the system may share the ROW but not track with freight and operate at restricted speeds.
	Best represented by Japanese high-speed surface transport (HSST) trains, with speeds up to 125 mph. The system may be constructed in new fully grade-separated corridors, and avoids the use of freight railroad ROW where possible.
	Best represented by the German TransRapid system and Shanghai system, with speeds from 250 to 300 mph. The system would be constructed in new fully grade-separated corridors and avoid the use of freight railroad ROW where possible.
	Emerging innovative systems with speeds over 110 mph that might be available by 2017 to dovetail with the timeline requirements of the AGS project.

EXHIBIT 4-23: SUMMARY OF SEGMENT SCORING – LEVEL 1 EVALUATION













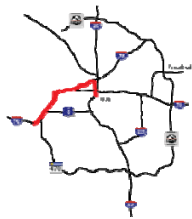
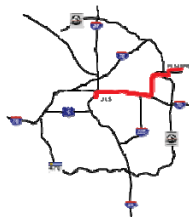

Segment Name	Disposition	Segment Name	Disposition
W-1: US 6/Gold Line/DUS 	Set Aside: <ul style="list-style-type: none"> ▪ Public acceptance not likely ▪ Inefficient space in the BNSF/ Gold Line corridor ▪ Significant community impacts ▪ Limited capacity in existing transit/railroad corridors ▪ High costs due to structures and new ROW ▪ Limited to FRA-compliant technology 	E-1: DUS/CML/I-70/ East Corridor/DIA 	Set Aside: <ul style="list-style-type: none"> ▪ Insufficient ROW available ▪ High community impact ▪ Likely resistance from the railroads ▪ High costs anticipated
W-2: I-70/I-76/DUS 	Set Aside: <ul style="list-style-type: none"> ▪ Unlikely public acceptance ▪ Limited flexibility ▪ High cost due to structures ▪ Reconsider only if Scenario C-1 is found acceptable 	E-2: DUS/CML/I-70/Pena/DIA 	Carry Forward
W-3: I-70/New Stockyard Station 	Carry Forward	E-3: New Stockyard Station/I-70/Pena/ DIA 	Carry Forward
W-4: I-70/US 6/DUS 	Carry Forward	E-4: DUS/CML/96th Avenue/DIA 	Carry Forward
NS-1: CML 	Carry Forward	NS-2: CML and Joint Line 	Carry Forward

EXHIBIT 4-23: SUMMARY OF SEGMENT SCORING – LEVEL 1 EVALUATION

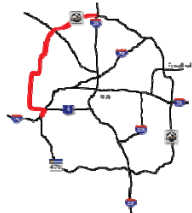
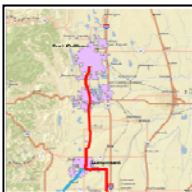
Segment Name	Disposition	Segment Name	Disposition
B-1: Northwest Quadrant 	Set Aside: <ul style="list-style-type: none"> The City of Golden does not support this segment Unknown environmental risks associated with a greenfield alignment 	N-1: Railroad Alignment 	Carry Forward
B-2: Southwest Quadrant 	Carry Forward	N-2: Greenfield 	Carry Forward
B-3: Southeast Quadrant 	Carry Forward	S-1: Railroad Alignment 	Carry Forward
B-4: Northeast Quadrant 	Carry Forward	S-2: Greenfield 	Set Aside: <ul style="list-style-type: none"> Extremely high level of stakeholder resistance for any segment travelling through the Black Forest community

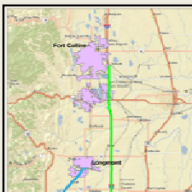
4.7 Level 1 Scenarios

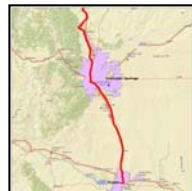
As shown on **Exhibit 4-24** the Level 1 Evaluation concluded that of the twelve HST scenarios considered, five were proposed for ridership modeling and seven were set aside. This does not necessarily mean that no portions of the remaining seven scenarios were considered in later evaluation. Rather, modeling of the five scenarios selected is expected to represent the best comparisons for future planning. For example, modeling results helped the study team to answer the following questions:

- What is the effect of stopping at DUS versus some other central Denver station location?

- What are the differences in travel time, ridership, and cost-effectiveness between scenarios that circumvent urban areas versus those that pass through urban areas?
- What is the effect on ridership if HST is constructed as a complete beltway around the Denver metro area versus a partial beltway or a beltway that traverses only the east or west portions of the Denver metro area?
- What are the impacts of following existing railroad alignments north to Fort Collins or south to Colorado Springs compared to a straighter, faster greenfield segment?

EXHIBIT 4-24: SUMMARY OF HST SCENARIOS CARRIED FORWARD

Description and Recommendation: A-Series Scenarios

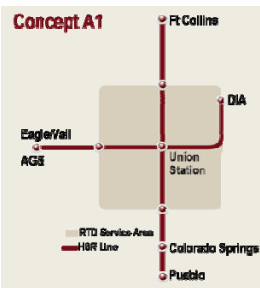
**A-1: Direct Alignments through Denver**

CARRY FORWARD: This scenario was carried forward to test the ridership of a direct connection through the Denver metropolitan area. This alignment is also highly supported by the I-70 mountain corridor stakeholders as it is considered critical to the success of the AGS. Other benefits include:

- Shortest and possibly fastest alternative
- One-seat ride to the most destinations
- Provides contrast to beltway segments
- Allows consideration of all technologies

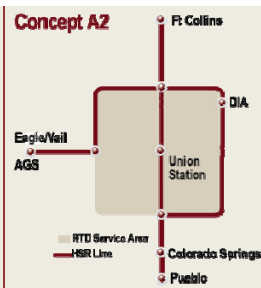
**A-2: Beltway Excluding the Southwest Quadrant**

SET ASIDE: This scenario was not recommended for modeling because A-1, A-5, and A-6 are anticipated to provide a better test of ridership.

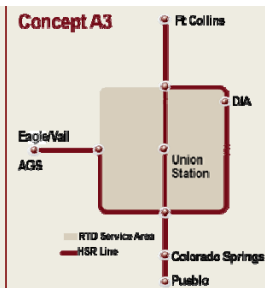
**A-3: Beltway Excluding the Northwest Quadrant**

SET ASIDE: This scenario was not recommended for modeling because A-1, A-6, and B-2A are anticipated to provide a better test of ridership.

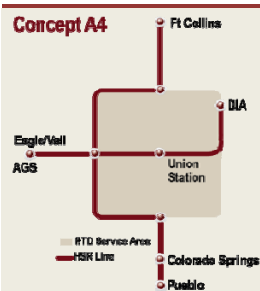
**A-4: Western Beltway**

SET ASIDE: This scenario was not recommended for modeling because A-1 and A-6 are anticipated to provide a better test of ridership.

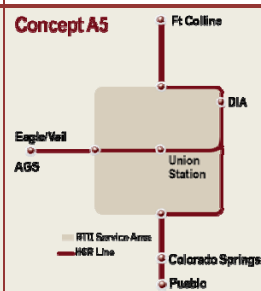
**A-5: Eastern Beltway**

CARRY FORWARD: This scenario was recommended for modeling because it is anticipated to be the lowest-cost option of the A-series scenarios. Other benefits include:

- Provides a one-seat ride to DIA
- Supportive of the AGS ridership
- Allows consideration of all technologies

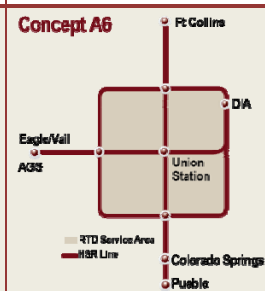
**A-6: Complete Beltway**

CARRY FORWARD: This scenario was recommended for modeling because it is anticipated to provide the best ridership of the scenarios considered in the Level 1 Evaluation. Other benefits include:

- Provides one-seat ride in all directions
- Supportive of the AGS ridership
- Potentially highest ridership alternative
- Test as a comparison to all others
- Demonstrates the case for diminishing returns in ridership versus cost
- Allows consideration of all technologies

EXHIBIT 4-24: SUMMARY OF HST SCENARIOS CARRIED FORWARD

Description and Recommendation: B and C-Series Scenarios		
<p>Concept B1</p>	<p>Concept B2</p>	<p>Concept B2A</p>
<p>B-1: Denver Periphery SET ASIDE: This scenario was not modeled because C-1 would be more representative of the Purpose and Need and would provide continuous HST service through the Denver metropolitan area to other portions of the state.</p>	<p>B-2: Denver Periphery Excluding the Southeast Quadrant SET ASIDE: This scenario was not recommended for modeling because A-2 and B-2A are anticipated to perform better due to the fact that both provided service to southeast Denver, whereas B-2 does not.</p>	<p>B-2A: Denver Periphery Excluding the Northwest Quadrant CARRY FORWARD: This scenario was recommended for modeling as it is important to test a peripheral alignment around the Denver metropolitan area against a direct east-west alignment through Denver such as provided by A-1, A-4, A-5, and A-6. Other benefits include:</p> <ul style="list-style-type: none"> Anticipated to be the best performing of the B-series segments Avoids the unknowns in the Northwest Quadrant Allows consideration of all technologies outside of the RTD system
<p>Concept B3</p>	<p>Concept B4</p>	<p>Concept C1</p>
<p>B-3: Denver Periphery Eastern Beltway SET ASIDE: This scenario was not recommended for modeling; Scenario A-5 will be used to test the ridership effectiveness of an eastern beltway alignment.</p>	<p>B-4: Denver Periphery Full Beltway SET ASIDE: This scenario was not recommended for modeling; Scenario A-6 will be used to test the ridership effectiveness of a full beltway alignment.</p>	<p>C-1: Denver Periphery Shared Track with RTD CARRY FORWARD: This alternative scenario was recommended for modeling because it tests the effectiveness of sharing existing RTD track for HST. Other benefits include:</p> <ul style="list-style-type: none"> Second lowest-cost scenario Low environmental impacts Provides a one-seat ride It was determined that a new segment will need to be developed during the Level 2 Evaluation to accommodate HST technology south of DUS through the Denver metropolitan area.

Section 5: Level 2 Evaluation

5.1 Scenarios Carried Forward from the Level 1 Evaluation

As a result of the Level 1 Evaluation, five scenarios were recommended for further analysis and carried forward into the Level 2 Evaluation:

- A-1: Direct Alignments through Denver
- A-5: Eastern Beltway
- A-6: Complete Beltway
- B-2A: Denver Periphery Excluding the Northwest Quadrant
- C-1: Denver Periphery Shared Track with RTD

5.1.1 Additional Segments Resulting from the Level 1 Evaluation

At the end of the Level 1 Evaluation, three new segments were recommended as a result of the public process or through further review by the study team. These new segments were refined in the Level 2 Evaluation. They include:

- **I-70 ROW/I-76 ROW/96th Avenue/DIA** – Use of the I-76 ROW from I-70 traveling east to 96th Avenue to DIA. A new station would be provided near the intersection of the North Metro Commuter Rail Line and I-76 (essentially I-76 and 72nd Avenue). DUS would not be accessed in the east-west direction. This became Option A for Scenarios A-1 and A-5, referred to hereafter as A-1A and A-5A.

Use of US 6 ROW for Scenarios A-1 and A-5 in place of I-76 ROW became Option B and is referred to hereafter as A-1B and A-5B.

- **New Greenfield Segment from Denver to Colorado Springs and Pueblo** – Due to concerns about impacts to the Black Forest community, the S-2:Greenfield Segment was eliminated at the end of the Level 1 Evaluation. The S-1: Railroad Alignment Segment was redefined as the new greenfield segment. This segment generally follows the I-25 and BNSF ROWs from south Denver to Colorado Springs and Pueblo.

- **Revisions to Scenario C-1: Denver Periphery Shared Track with RTD** – Because it is not possible to share either the RTD Southeast or Southwest LRT track with HST technologies, a new guideway was recommended from DIA to the South Suburban Station. This new guideway will follow the E-470 ROW exactly as configured for Scenarios A-5 and B2A.

Sharing track with RTD’s East Commuter Rail Line to DIA, North Metro Commuter Rail from DUS to the north, and the Gold Line Commuter Rail from DUS to Golden is still being considered as part of this scenario.

5.1.2 Packaging and Modification of Level 2 Scenarios

During the Level 1 Evaluation, five of the 18 segments evaluated were dismissed, and the remaining segments were packaged into the final five scenarios listed above. During the Level 2 Evaluation, several refinements of these scenarios were required, as described below.

Scenarios A-1 and A-5 were carried into the Level 2 Evaluation with few changes. However, because it was not possible to define the most acceptable east-west segment through the Denver metro area, two design options were retained for each scenario: Option A: I-76 and Option B: US 6.

The north-to-south routings for Scenario A-1 remain the same: Segments NS-1: CML and NS-2: CML/Joint Line.

One west-to-east routing using the W-3: I-70/New Stockyard Station and the E-2: DUS/CML/I-70/Pena Boulevard to DIA segments was eliminated because incorporation of a HST system into the CDOT proposed I-70 reconstruction program was considered unacceptable due to community impacts.

Scenario A-6 was found to be too costly at over \$20 billion and was dismissed. It was replaced with a different scenario, **B-5: Denver Periphery – Northwest**, on the advisement of the PLT representatives from the northwestern Denver metro area.

Scenario B-2A was carried forward into the Level 2 Evaluation with no changes from Level 1.

Scenario C-1 was modified by adding construction of HST on the E-470 ROW (defined as Segment B-3 in the Level 1 Evaluation Report) from DIA to the South Suburban Station, as described previously.

The five remaining scenarios were then refined with additional engineering and environmental considerations. The improved scenarios were measured for cost-effectiveness through the use of ridership modeling and Benefit/Cost Analysis (BCA). The refinements were presented at several PLT meetings and at five public open houses.

5.2 Level 2 Evaluation Commitments

At the conclusion of the Level 1 Evaluation, the Next Steps described below were defined, forming the basis for the Level 2 Evaluation.

5.2.1 Engineering Studies

The Level 2 Evaluation engineering studies involved preparing concept-level CADD drawings for each scenario in order to:

- Assess each segment making up the scenario, in particular the curvilinear constraints, to predict the possible top speed of the HST technology
- Determine the general construction footprint of each segment and scenario
- Begin to assess the quantity of aerial structures or tunnels compared to at-grade track
- Provide a conceptual estimate of the property acquisition requirements
- Assess the level of community impact
- Provide parametric cost estimates

5.2.2 Planning Studies

- Preliminary operating plan assumptions were prepared, including headways (interval between trains), number of trains per hour, dwell times at stations (the amount of time a train is stopped at a station for passenger boarding and alighting), and train capacity requirements.

Additional planning tasks included:

- Preparing a conceptual assessment of the overall social, economic, and environmental benefits associated with implementing HST
- Developing assumptions on the types of technologies to be considered
- Defining general station locations
- Defining the general programming requirements for stations to define ROW needs
- Determining the need for maintenance facilities and other support facilities to estimate costs and ROW needs
- Preparing the travel demand model and preliminary ridership estimates
- Calculating preliminary revenue estimates
- Defining preliminary funding requirements
- Gaining agreement on the approach to the benefit/cost analysis
- Preparing preliminary benefit/cost estimates
- Assessing the level of environmental and community impacts

5.2.3 Public Involvement

- Additional PLT meetings were held in December 2012.
- Public open houses were conducted in Colorado Springs and Pueblo on May 29 and 30, 2013, and in Winsor and Denver on June 5 and 6, 2013. A fifth meeting was held in Silverthorne on June 11, 2013.
- The study team conducted special geography-based meetings with the PLT and stakeholders in Denver, Fort Collins, Colorado Springs, Pueblo, and Silverthorne to discuss specific issues related to the location of HST through or around their communities.
- The website was updated as work was developed.

5.3 Level 2 Evaluation Methodologies

A summary of the methodologies used to evaluate the Level 2 alternatives is presented below, and includes:

- Engineering and Cost Estimating Methodology
- Level 2 Service Plan Methodology
- Level 2 Operations and Maintenance Cost Methodology
- Ridership and Revenue Estimation Methodology
- Public Benefits and Environmental Analysis Methodology
- Benefit/Cost Analysis Methodology

Greater detail on each methodology is provided in report Appendices.

5.3.1 Engineering and Cost Estimating Methodology

In the Level 2 Evaluation, the capital cost-estimating process included six steps:

1. The study team conducted field inspections of the alignments surviving the Level 1 Evaluation.
2. The scenarios were divided into segments.
3. Guideway and other capital improvements were defined based on the physical features of the segment.
4. Quantities were estimated for the ten FRA Standard Cost Categories (SCC) developed as part of its HST Program:

10	Track Structures and Track
20	Stations, Terminals, Intermodal
30	Support Facilities: Yards, Shops, Administrative Buildings
40	Site work, Right of Way, Land, Existing Improvements
50	Communications and Signaling
60	Electric Traction
70	Vehicles
80	Professional Services
90	Unallocated Contingency
100	Finance Charges
5. The quantities were then multiplied by unit costs prepared by the study team based on other

existing HST programs around the country and local conditions.

6. A conceptual plan-set was prepared for use as the basis for estimating the quantities.

Detailed Level 2 Evaluation cost information is provided in Appendix B, ICS Engineering Reports and Supporting Information. The CAPEX Estimating Methodology Manual is available on the ICS website: <http://www.coloradodot.info/projects/ICS>.

5.3.2 Level 2 Service Plan Methodology

Preliminary service plans were developed for each of the five Level 2 scenarios. These service plans were intended to define representative levels of rail service for use in ridership forecasting and developing general operating and maintenance cost estimates. Level 2 service plans were developed based on the following guidance:

- Service patterns were simplified as much as practical. For example, rail service along the north-south corridor assumes all trains serve the full length from Fort Collins to Pueblo, rather than defining “short lines” (e.g., Fort Collins to Colorado Springs) as a method to provide additional coverage in the core segment. Assuming service along the full length of the line allows for the full potential to generate ridership. For the Level 3 Evaluation, ridership results were analyzed to refine service plans and tailor service levels to demand in order to maximize service efficiency.
- Service to Breckenridge is assumed to be a branch, rather than an in-line station to Eagle County Regional Airport. Thus, east-west trips are split on the west end so that, while a majority of trips proceed to Eagle County Regional Airport, several trips instead serve the branch to Breckenridge. As the east-west corridor continues to be refined, this branch concept may be modified for Level 3.
- The service span for all HST corridors is assumed to be 18 hours each day (e.g., 6 a.m. to midnight), seven days per week. For the north-south corridor, service is envisioned to follow a typical commute profile where more service is offered during weekday peak periods. For service related to the I-70 mountain corridor, heavier service is likely to occur near the end of

the week and on weekends, with lighter service during the earlier weekdays.

- For the north-south and east-west corridors, a basic frequency of 24 round trips per day was assumed for days requiring heavier service. This represents an 18-hour daily span (e.g., 6 a.m. to midnight), with 30-minute service in the peak period (3 hours in the morning and 3 hours in the afternoon) and hourly service for the remaining 12 hours.
- As a sensitivity test, a more aggressive level of service of 36 round trips per day also was defined. Still representing an 18-hour daily span, this level corresponds with 15-minute service in the 6-hour peak period (split between a.m. and p.m.) and hourly service for the remaining 12 hours. This level of service also supports the east-west capacity assumption of 4,900 passengers per hour, and is therefore referred to as the Capacity Service Plan.
- For scenarios where the north-south corridor meets the east-west corridor in the vicinity of DUS, I-76/72nd, or DIA (e.g., A-1 and A-5), transfers are required between lines as it is generally infeasible to have a train movement that turns off one corridor and onto the other at these locations.
- For scenarios using the beltway (i.e., B-2A and B-5), selected line patterns may directly connect part of a north-south corridor with part of an east-west corridor, e.g., Pueblo to Eagle County Regional Airport. In these cases, service in the trunk (common segment before service splits off) maintains the target number of round trips per day. The relative split of trips is generally advised by a preliminary ridership forecast using a complex service plan from the RMRA *High-Speed Rail Feasibility Study Business Plan* (March 2010), which provided direct service between numerous market combinations.

5.3.3 Level 2 Operations and Maintenance (O&M) Cost Methodology

Because Level 2 screening still involves a large number of scenarios, a straightforward method of quantifying O&M costs for comparison purposes is appropriate. Toward this end, the calculated unit costs per train mile from the operating cost analysis provided in the RMRA Study are applied to

alternatives in the Level 2 Evaluation. The RMRA Study developed operating costs for six technology types:

- 79 miles per hour (mph) diesel rail
- 110 mph electric rail
- 125 mph magnetic levitation (Maglev)
- 150 mph electric rail
- 220 mph electric rail
- 300 mph Maglev

The RMRA Study used a cost build-up method, adapting the costing framework developed for the Midwest Regional Rail System. Nine specific cost areas were identified, as summarized in **Exhibit 5-1**.

EXHIBIT 5-1: OPERATING COST CATEGORIES AND DRIVERS

Cost Category	Cost Driver	Technology Distinction
Train Equipment Maintenance	Train Miles	Yes
Energy and Fuel	Train Miles	Yes
Train and Engine Crews	Train Miles	Yes
Onboard Service Crews	Train Miles	No
Insurance	Passenger Miles	No
Sales and Marketing	Fixed Cost, Ridership and Revenue	No
Service Administration	Fixed Cost, Train Miles	No
Track and ROW Maintenance	Track Miles	Yes
Station Costs	Number of Stations	No

Source: RMRA *High-Speed Rail Feasibility Study Business Plan*, March 2010.

As noted in **Exhibit 5-1**, the RMRA O&M cost method includes distinctions based on technology differences in several cost areas: Train Equipment Maintenance, Energy and Fuel, Train and Engine Crews, and Track and ROW Maintenance.

The unit cost for Train and Engine Crews is influenced by train speed. Technologies with higher operating speeds will have less cost for Train and Engine Crews because those technologies can operate the same service plan in less time. The RMRA Study notes that Train Equipment

Maintenance is considerably less for Maglev than for electric rail. The RMRA Study's unit cost used for 300-mph Maglev for Train Equipment Maintenance is 45 percent lower compared to 220-mph electric rail. The difference is 17 percent when comparing 125-mph Maglev to 150-mph electric rail.

The unit cost used for Energy and Fuel in the RMRA Study varies depending on grade. The RMRA Study's unit cost for 300-mph Maglev is 8 to 24 percent less than for 220-mph electric rail, depending on the grade. The 125-mph Maglev technology, however, has a higher unit cost than the 150-mph electric rail option for Energy and Fuel. Both electric rail and Maglev technologies have substantial lower Energy Fuel unit costs than diesel technology options.

It is important to note that these cost differences by technology only apply to portions of the overall cost estimate. For example, while Maglev is 45 percent less expensive than 220-mph electric rail Train Equipment Maintenance, this particular cost category is just 26 percent of the overall cost for 220-mph electric rail. Thus, the 45 percent cost savings associated with Maglev applies only to this particular cost category.

Associated statistics were developed for each technology option in the RMRA Study and were applied to the O&M cost model. This led to the calculation of total annual operating costs in 2008 dollars for each system option. The total costs were then divided by the total train miles in order to express an average cost per train mile. **Exhibit 5-2** lists the resulting average cost per train mile as calculated in the RMRA Study, which was escalated to 2013 dollars using the Bureau of Labor Statistics Consumer Price Index – Urban Consumers (CPI-U) for the Denver-Boulder-Greeley region.

EXHIBIT 5-2: AVERAGE OPERATING COST PER TRAIN MILE BY TECHNOLOGY

Technology	Cost Per Train Mile (2013 \$)
79-mph Rail	\$56.89
110-mph Rail	\$54.61
125-mph Maglev	\$49.58
150-mph Rail	\$53.79
220-mph Rail	\$54.73
300-mph Maglev	\$41.56

Source: RMRA *High-Speed Rail Feasibility Study Business Plan*, March 2010.

An escalation factor of 1.07 was determined by comparing the annual CPI-U from 2008 to 2012. Further escalation to 2013 dollars was achieved by assuming the same annual growth rate as 2011 to 2012, leading to an escalation of 1.09 of the 2012 dollars.

Rail operating plans were developed in order to estimate the annual train miles for each of the Level 2 scenarios. For all scenarios, a Basic Service Plan was developed, as well as the more aggressive Capacity Service Plan described previously³. The Basic Service Plan generally allowed for 24 daily round trips per corridor, whereas the Capacity Service Plan was based on 36 daily round trips per corridor. The service plan for Scenario A-6 showed appreciably more service; use of the complete beltway allowed additional service directly linking markets outside of Denver while maintaining service patterns through Denver.

To determine the OPEX costs for the Level 2 Evaluation, the annual train-miles for each scenario were multiplied by the RMRA-calculated average cost per train mile in 2013 dollars.

5.3.4 Ridership and Revenue Estimation Methodology

The ICS ridership studies applied a well-established travel demand forecasting methodology to analyze ridership and revenue for the Level 2 scenarios. This methodology is quite detailed and is well suited to Level 2 Evaluation purposes. Study team modelers met with MPO modeling staff to obtain concurrence on the methodology. A full report is included in Appendix D, ICS Demand Forecasting Model Documentation.

Exhibit 5-3 illustrates the forecasting approach, which addresses four distinct travel markets (discussed below) in the ICS study area:

- Inter-urban travel market
- Intra-urban (Denver metro area) travel market
- Airport choice market
- Induced travel market
-

³ Basic Service Plan: 30-minute headways during peak operation (6 hours/day) and 60-minute headway during the off-peak (12 hours). Capacity Service Plan: 15-minute headways during peak operation (6 hours/day) and 60-minute headway during the off-peak (12 hours).

EXHIBIT 5-3: ILLUSTRATION OF THE FORECASTING APPROACH

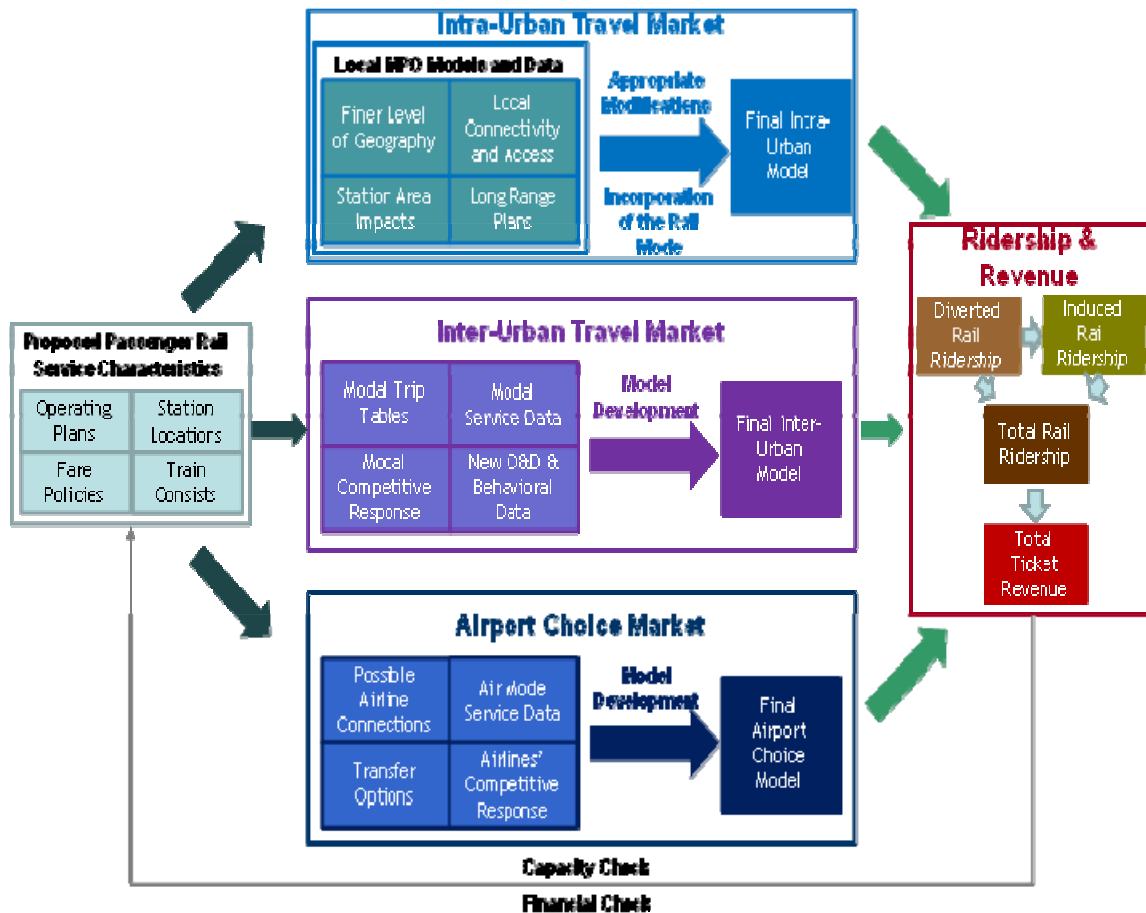

To forecast demand for a rail scenario (combination of technology and speed, alignment, and stopping pattern), the model requires information on the scenario's service characteristics. These include:

- Operating characteristics - stopping patterns, running and dwell times, schedule, or frequency
- Station-to-station fares
- Station locations and connectivity/accessibility/-parking

Inter-Urban Travel

The process that the demand model applies to forecast the inter-urban ridership and revenue of a proposed rail service entails five broad steps:

1. *Establish the study area's geographic scope and zone structure:* The intercity model covers a geographic area that generally follows the ICS corridors and extends approximately 50 miles on each side of the proposed alignments. The study area was split into 3,142 zones. In MPO areas,

the zones were based on the local MPO model traffic analysis zones (TAZs) or some aggregation of them; in other areas, they were based on zones used in the I-70 Mountain Corridor PEIS.

2. *Develop input data including service characteristics for each mode and zone pair:* Modeling input data included the study area network, historic and future socio-economic variables (e.g., population, employment, income, general economic conditions, information on visitors, commuters, etc.), and information about the service characteristics of existing and future travel modes.
3. *Estimate the current in-scope travel market:* The inter-urban travel market includes trips by air, bus, and private automobile for different travel purposes. As part of the forecasting model development, data on the patterns and levels of trip making in these markets was prepared on a detailed zone-to-zone basis. While intercity air

volume data is available from well-established sources and intercity bus volumes can be adequately estimated from published schedules, the lack of detailed up-to-date information on inter-urban automobile travel in the study corridor was a serious data gap. This prompted the study team to undertake a program of original travel data collection, using anonymous cell phone data to understand the origins and destinations of auto travelers in the corridor.

4. *Estimate how this market will grow in the future:* This step involved the development of econometric travel growth models for the automobile and bus modes, reflecting trends in socio-economic variables such as population and employment. Future-year air trip tables were prepared based on published Federal Aviation Administration (FAA) terminal area forecasts of total annual airport enplanements for each of the study area airports.
5. *Estimate the potential market share that the new rail service will capture (i.e., the ridership):* A standard model form (called a nested logit model) was used to predict the market share of each intercity mode based on the respective service characteristics of the modes in competition between each zone pair. Service characteristics include time, cost, frequency, reliability, and quality of service, with time and cost broken down into their access, egress, transfer, terminal, and line haul components. Mode-specific constants account for the effects of other (not explicitly modeled) characteristics of rail relative to other modes. These shares are then applied to the total zone-to-zone travel volume to predict the volume of travel by each mode, including the new rail mode. This process is carried out separately for the different trip purposes, and the results are aggregated.

The nested logit model incorporates information about how travelers assess and trade off different modal service characteristics. This information was obtained from Stated Preference (SP) surveys of study area residents conducted as part of the forecasting effort. This type of survey is routinely used to elicit traveler preferences and tradeoffs involving different modal attributes. See Appendix D, ICS Demand Forecasting Model Documentation, for more information.

Intra-Urban Travel

As all the Level 2 scenarios include multiple stations in the Denver metro area, all will provide intra-urban as well as inter-urban service. The travel forecasting activity considered interactions between the rail project and the Denver metro transportation system both in regard to the metropolitan access/egress portion of inter-urban ICS rail trips and functioning of the ICS project as a local travel mode within the Denver metro area. The forecasting activity used the Denver Regional Council of Government's (DRCOG) Compass model to forecast Denver metro area ICS project travel demands, treating the rail project as an additional transit mode within the already-defined mix of transit modes, with adjustments as required. This approach makes maximum use of the detailed understanding of Denver metro area travel patterns and behavior already embodied in the Compass model system.

Airport Choice

DIA is an important national international hub due to the large number of destinations served and the presence of major air carriers. Locally, it provides connection options for air trips that begin or end at the study area regional airports: Colorado Springs (COS) and Eagle County Regional (EGE). Because all of the Level 2 scenarios include a rail station at DIA, people travelling to or from COS or EGE who need to make a connection at DIA would have the option of using either air or rail. The ICS travel demand forecasting effort developed an airport choice model to forecast these potential shifts by connecting air travelers.

Induced Travel

Induced travel refers to trips that were not made before a project opens, but which will be made as a result of the mobility and accessibility improvement that the project brings. Induced travel resulting from the introduction of the Level 2 rail alternatives was forecasted using a simple elasticity-based approach, where the elasticity is expressed as the percentage impact on travel volumes resulting from a percent change in accessibility. Accessibility, in turn, was defined in terms of a generalized cost or log sum variable computed from the nested logit model developed for this study from the collected SP survey data.

5.3.5 Public Benefits and Environmental Analysis Methodology

The ICS has developed and evaluated scenarios that were built off the alternatives configured by the RMRA Study completed in March 2010. The environmental impact analysis provides a basis to evaluate, compare, and screen scenarios for implementing HST in Colorado. The purpose of environmental impact analyses at this stage in corridor development is not to meet National Environmental Policy Act (NEPA) analysis standards, but to document how environmental criteria were used in making decisions.

The ICS evaluated two types of alignments for implementing HST along the Front Range:

1. Those following existing transportation corridors; and
2. Those following “greenfield” alignments that do not significantly constrain the curvature requirements of HST.

The ICS also evaluated alignments through and around the Denver metro area. The AGS alignments west of Denver will be evaluated in the AGS Feasibility Study. The ICS has three levels of evaluation, each integrating environmental factors. The ICS considers the following environmental and social factors defined in the ICS Master Scope of Work (SOW):

- Air quality
- Noise
- Energy and congestion
- Land use and development effects, including TOD potential
- Fuel cost savings
- Initial and permanent employment changes
- Safety benefits
- Reliability
- Consumer surplus – a user benefit similar to the estimated time and cost savings often cited in evaluating highway projects

Other environmental measures as discussed below.

A high-level environmental review of each Level 2 scenario was conducted to determine sensitive communities or natural resources that may be

potentially affected. These may include but are not limited to historic resources, regulated materials, wetlands, and parks or recreation resources. A calculation of “acres disturbed” has also been added to help assess the absolute impact of the construction of any considered scenario.

The Level 2 Evaluation included more detail on alignment footprints, ridership, and cost estimates. Engineering was advanced to support evaluation of the physical characteristics of the remaining alignments, including identifying basic ROW needs, focusing on the widths and capacities of existing transportation corridors. The evaluation defined resources that may be highly sensitive to impact based on input from resource agencies, community organizations, and the public. The scenarios were refined and evaluated using quantitative measures to compare performance and to advance options with the potential to offer statewide social, environmental, and economic benefits that are greater than the capital and operating costs of implementation. The evaluation and measurement of environmental impacts during the Level 2 Evaluation was supported by existing mapping and environmental data (available through recent NEPA studies) and newly developed travel demand modeling data.

Environmental factors were most discriminating during the Level 2 Evaluation. While environmental factors were considered at Level 1 and again at Level 3, political and policy matters, cost-effectiveness, and financial issues will likely be greater drivers in the decision process.

5.3.6 Benefit/Cost Analysis Methodology

The project Purpose and Need states that any selected HST scenario need to “*offer statewide social, environmental, and economic benefits that are greater than the capital and operating costs of its implementation.*”

Two benefit/cost analyses (BCA) were prepared:

- **Calculation of the Operating Ratio (OR)** – As required to determine FRA feasibility, the OR was calculated by dividing the sum of all revenues by the OPEX estimate.
- **Calculation of Project Benefit/Cost Ratio (B/C Studies)** – Public support for the HST requires an undisputed BCA methodology that is endorsed by both the PLT and the public. The

methodology and the results were presented to both the PLT and the public for comment.

It is anticipated that the introduction of HST in Colorado would divert trips away from the highway system and, to a lesser extent, the aviation system, and fewer trips could reduce accidents and the discharge of pollutants to the atmosphere, all of which are expected to generate substantial benefits to the state's residents. As referenced in the project Purpose and Need, a B/C ratio greater than 1.0 is a condition for acceptance of the Colorado HST Program.

The B/C ratio has been calculated by comparing monetized quantitative measures of benefit to the present worth of the annualized capital and O&M costs of the system.

HST benefits that were considered include the following:

1. Passenger revenue
2. Reductions in VMT
3. Reductions in highway delay
4. Reductions in accidents and fatalities
5. Reductions in atmospheric pollution
6. Reductions in aviation delay (if any)
7. Reductions in highway investment requirements
8. Reductions in aviation investment requirements
9. Increases in property tax revenue around HST stations (tax increment basis)
10. Increases in employment income from the construction and operation of the HST system
11. Increases in state personal income through the infusion of major federal grants assumed to partially fund the selected HST scenario

HST costs are expected to include the following:

1. All operating and maintenance costs (OPEX)
2. All capital costs, including ROW and "soft costs" (CAPEX)

The operating life assumed for the B/C studies is 30 years; long-term interest for bonding was assumed at 4 percent; and inflation is expected to average 3.5 percent per year.

5.4 Description of Level 2 Scenarios

The five remaining scenarios (with two design options) are described in the following narrative. This discussion serves as the basis for the cost, operational, ridership, and environmental results presented later in this section.

Four of the five scenarios – A-1, A-5, B-2A, and B-5 – involve the construction of all new alignment. One scenario, C-1, shares track with RTD within the Denver metro area, eliminating the need to construct approximately 40 miles of new track.

Where the scenarios share common elements, the description is not repeated but referenced to previous narratives. Consequently, descriptions for the following are not repeated:

- Segments to Fort Collins and to Pueblo are the same for all five scenarios.
- Station locations are generally the same for the five scenarios, with two exceptions that are noted in the narrative.
- One maintenance and four layover facilities are assumed for scenarios A-5, B-2A, B-5, and C-1; two maintenance and three layover facilities are assumed for scenario A-1.

The major difference between the five scenarios is the configuration through the Denver metro area. Scenarios that have alignments through the metro area (A-1 and A-5) typically require about 10 more miles of elevated structure than the other scenarios. This is due to the need to "fly over" existing roadways and other urban features.

5.4.1 Scenario A-1: Direct Through Denver

The intent of Scenario A-1 is to run directly through the Denver metro area with the shortest routes and potentially fastest travel times possible. This scenario is also believed to most directly serve the densest population centers within the Denver metro area. The tradeoff for direct access is the need to acquire new ROW and the associated impacts for the majority of the segments that pass through the metro area.

A schematic of Scenario A-1 is shown below.

Scenario A-1 (also refer to Exhibit 5-4)

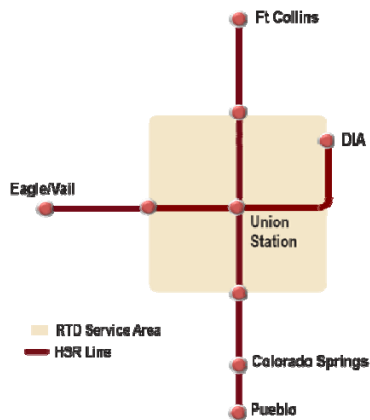

Technology

Both FRA compliant and non-compliant technologies are possible with this scenario.

Alignment (See Exhibit 5-4)

East-to-West through Metro Denver

There are two design options traveling east to west through the Denver metro area:

- Option A: I-76
- Option B: US 6

Option A: I-76 (A-1A)

From the West Suburban Station in the vicinity of I-70 and C-470, the alignment proceeds northeasterly along the south ROW of I-70 to transition to elevated structure over US 6 and then Colfax Avenue. At this point, the alignment moves to grade along the south side of I-70 to SH 58 and remains at-grade or on retained fill until it elevates over Kipling Street and Wadsworth Boulevard.



The alignment remains elevated as it flies over the I-70/I-76 interchange and then continues on a combination of at-grade, retained fill, and elevated structure along the south side of I-76 to an elevated structure over Sheridan Boulevard. It then returns to grade for a short distance, becomes elevated over Federal Boulevard and Pecos Street, returns to grade for another short distance, and then flies over I-25.

The alignment remains on the south side of I-76, then flies over I-270, remaining on the south side of I-76 to 96th Avenue, where it travels east to E-470, down the west side of the tollway to just north of Pena Boulevard. It then flies over E-470 to the north side of East 78th to the DIA Terminal Station.

Option B: US 6 (A-1B)

From the West Suburban Station in the vicinity of I-70 and C-470, the alignment proceeds northeasterly along the south ROW of I-70 at-grade to US 6 (6th Avenue). Approaching the intersection with Indiana Street, the alignment elevates to an aerial structure that is approximately at the same elevation with the US 6 bridge over Indiana Street, but below the RTD West Line LRT flyover. East of Indiana Street, the alignment returns to grade along the south side of US 6 and continues east, crossing under the existing Union Boulevard overpass and RTD West Line LRT tied arch bridge over US 6. The alignment then rises on retained fill to an elevated guideway at approximately Parfet Street. At that point, the alignment transitions to the median of US 6 and continues easterly on the elevated guideway, crossing over the major interchanges of Kipling Street, Wadsworth Boulevard, and Sheridan Boulevard.

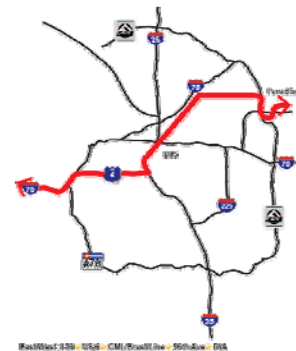

East of Sheridan, the alignment on elevated guideway transitions to the north side of US 6 and descends along retained fill to grade at approximately Perry Street. The alignment then continues at-grade along the north side of US 6, crossing under the existing Federal Boulevard overpass before rising on retained fill to an elevated structure just west of the South Platte River. On the elevated structure, the alignment generally parallels US 6 to cross over I-25. The alignment then begins to curve northeasterly to cross under the existing eastbound (EB) 6th Avenue to the northbound (NB) I-25 connector ramp and over the westbound (WB) 6th Avenue to the NB I-25 ramp. The alignment curve ends just after crossing over the CML. Remaining on an elevated guideway, the alignment continues northerly along the east side of the CML, crossing over Colfax Avenue and Auraria Parkway. The alignment then descends on retained fill to grade within the CML, crosses under Speer

Boulevard, and continues at-grade along the CML ROW to DUS. From DUS north, the segment follows the CML and Brush Line freight alignments to 96th Avenue, south along E-470, and it then ascends over E-470 east to DIA.

North-to-South through Metro Denver

In the narratives below the alignment is described as follows:

- From DUS to the North Suburban Station
- From DUS to the South Suburban Station

DUS North to the North

Suburban Station

From DUS, the alignment follows the CML north and under the 20th Street viaduct, then ascend on elevated structure over Park Avenue, eventually coming to ground to the west of the Union Pacific Railroad (UPRR) 36th Street Yard. From this point, the alignment continues north under I-70, paralleling the west side of the BNSF ROW at-grade, then elevating over I-270 at Clear Creek Junction and continuing on the west side of the freight rail tracks to E-470. From here, it flies over the tollway, following the north side of the ROW to the North Suburban Station.



DUS South to the South Suburban Station

From DUS, the alignment travels south parallel to the CML and under North Speer Boulevard, just to the west of the Pepsi Center; it then transitions to elevated structure over Auraria Parkway and West Colfax Avenue, then descends to grade near West 8th Avenue. At this point, the alignment parallels the CML, then transitions again to elevated structure over South Kalamath Street, South Santa Fe Street, West Alameda, and I-25. (The CML becomes the Joint Line at this location.) After passing over I-25, the alignment remains aerial and locates to the median of South Santa Fe Drive near West Jewell Avenue. The alignment remains elevated in the median of South Santa Fe Drive for the next 9.4 miles traveling south, coming back to grade just south of West Mineral Avenue. It then follows South Santa Fe Drive south and flies over the C-470/Santa Fe interchange to the south side of C-470. It remains on the south side of C-470 both at-grade and elevated over South University Boulevard, South

Quebec Street, South Yosemite Street, and I-25 to the South Suburban Station located east of I-25.

North to Fort Collins

There are two alignment options north to Fort Collins:

- N-1: North I-25 EIS Segment
- N-2: I-25 Segment

N-1: North I-25 EIS Segment

From the North Suburban Station in Thornton, this segment travels northwest following the UPRR ROW on retained fill until it flies over the UPRR tracks, County Road (CR) 6, and CR 11. The alignment then returns to retained fill until it flies over the I-25 North Frontage Road and I-25, landing on the west side of I-25 and following a northwesterly path to cross CR 7. The alignment follows CR 7 on the west side, alternating between retained fill and at-grade sections until just south of SH 119, where it flies to the south side of SH 119. The alignment then follows SH 119 on retained fill west to the BNSF rail alignment in Longmont and continues on the east side of the BNSF ROW through Loveland to Fort Collins. It is assumed that the HST will have separation with freight rail between Longmont and Fort Collins. The maximum speed is restricted to 90 mph in that section. The segment would terminate at the MAX Transit Center south of Harmony Road in Fort Collins.

N-2: I-25 Segment

From the North Suburban Station in Thornton, the alignment travels west along the north side of E-470, flies over NB I-25, and travels on elevated structure on the west side of I-25 until where just south of CR 6, it shifts into the I-25 median. The alignment remains in the I-25 median until it reaches the terminal station in Fort Collins. The alignment continues at-grade following the existing topography of the I-25 median while using retained cut/fill sections to reduce troublesome grades where necessary. Elevated structures 30 feet in height are used to fly over 23 highway crossings. The alignment ends at a station south of the East Prospect Road and I-25 interchange in Fort Collins.

South to Pueblo

From E-470, this alignment travels south on the east side of I-25 on elevated structure until Havana Street. The alignment then uses retained fill until it crosses Meadows Parkway, where elevated structure is required through urban Castle Rock. A retained fill

section is used until after Bell Mountain Parkway, where the alignment lowers to grade. After Gulch Road, the alignment continues on retained fill for 1.78 miles until it can lower to grade again. At East Greenland Road, the alignment uses a retained fill section for 1 mile and lowers to grade for 2 miles. At this point, the alignment flies over to the west side of I-25 and remains on elevated structure through urban Monument for 2.6 miles, and on a retained fill section for another 2.6 miles until it crosses to the east side of I-25. A retained fill section is maintained as the alignment continues to follow I-25 south.

After Academy Boulevard, an elevated structure is required to travel through urban northern Colorado Springs. Once the alignment reaches downtown Colorado Springs, it deviates from I-25, following the UPRR alignment on an elevated structure through Colorado Springs, lowering to grade under US 24, and elevating on structure again to Fort Carson. Maintaining a 30-foot elevated structure, the alignment deviates from the UPRR alignment and crosses to the west side of I-25, where it returns to grade for 3 miles. After Santa Fe Avenue, the alignment uses retained fill for about 5.5 miles, lowers to grade for another 1.5 miles, and alternates between retained fill and at-grade sections for the next 9.3 miles. Just north of Purcell Boulevard in north Pueblo, the alignment elevates to a 30-foot structure and leaves the I-25 corridor, heading southwest. After returning to grade immediately south of Purcell Boulevard, the alignment generally follows the existing BNSF corridor at-grade, then on retained fill through populated areas of West Pueblo, and then returns to grade south of 19th Street to meet the station in downtown Pueblo.

Stations

The Level 2 Evaluation is based on the following stations:

- DIA
- DUS
- I-76/72nd Avenue (Option A – I: 76 only)
- North Suburban
- West Suburban
- South Suburban
- Longmont/Berthoud
- Fort Collins
- Castle Rock

- Monument
- Colorado Springs
- Fort Carson
- Pueblo

The locations of these stations are general at the Level 2 Evaluation phase, as shown in **Exhibit 5-4**.

Operating Strategy

For the purpose of ridership forecasting, a Basic Service Plan was evaluated:

- **Basic Service Plan:** 30-minute headways during peak operation (6 hours/day) and 60-minute headway during the off-peak (12 hours)
- **Capacity Service Plan:** 15-minute headways during peak operation (6 hours/day) and 60-minute headway during the off-peak (12 hours)

The Basic Service Plan assumed 24 trains per day with trains operating from 6:00 a.m. to midnight. The Capacity Service Plan was evaluated to satisfy the I-70 PEIS ROD, which requires that any transit alternative have the capacity to carry 4,900 persons per hour, per direction. It also served as a means of testing the effects on system ridership resulting from a more aggressive service plan. Because the Capacity Service Plan was found to be cost-ineffective (operating costs surpassed gains in ridership), it was dismissed from further evaluation. The details of both service plans are presented in Appendix C, Service Plans and OPEX Estimating Support Materials.

The A-1 service plan provides a single north-south pattern from Fort Collins to Pueblo. The east-west pattern proceeds from DIA to either Eagle County Regional Airport or Breckenridge.

For A-1 with Option A (I-76), transferring from one high-speed train to another is achieved by taking the North Metro line between DUS and I-76/72nd, as shown in the A-1A schematic on the following page. As discussed later in the report, this transfer proved to have a significant negative impact on ridership. For Scenario A-1 with Option B (US 6), transfers between the two HST lines can occur at DUS, as shown in the Scenario A-1B schematic. Operating plan details for Scenario A-1 are summarized below:

- **Fort Collins to Pueblo:** 24 round trips daily - Stations: Fort Collins, Berthoud, North Suburban, DUS, South Suburban, Castle Rock, Monument, Colorado Springs, Fort Carson, Pueblo

- **DIA to Eagle County Regional Airport:** 21 round trips daily - Stations: DIA, I-76/72nd (A-1A) or DUS (A-1B), West Suburban, Georgetown, Silverthorne, Vail, Eagle Airport
- **DIA to Breckenridge:** 3 round trips daily - Stations: DIA, I-76/72nd (A-1A) or DUS (A-1B), West Suburban, Georgetown, Silverthorne, Breckenridge

Concept A1a
Direct Routing
through Denver
Basic Frequency
Service Plan

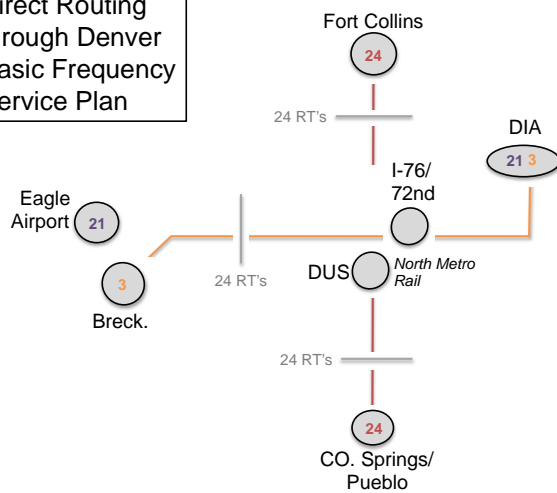

Concept A1b
Direct Routing
Through Denver
Basic Frequency
Service Plan

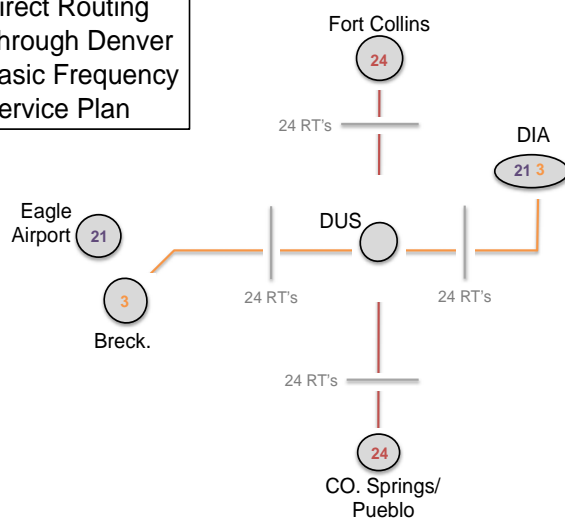
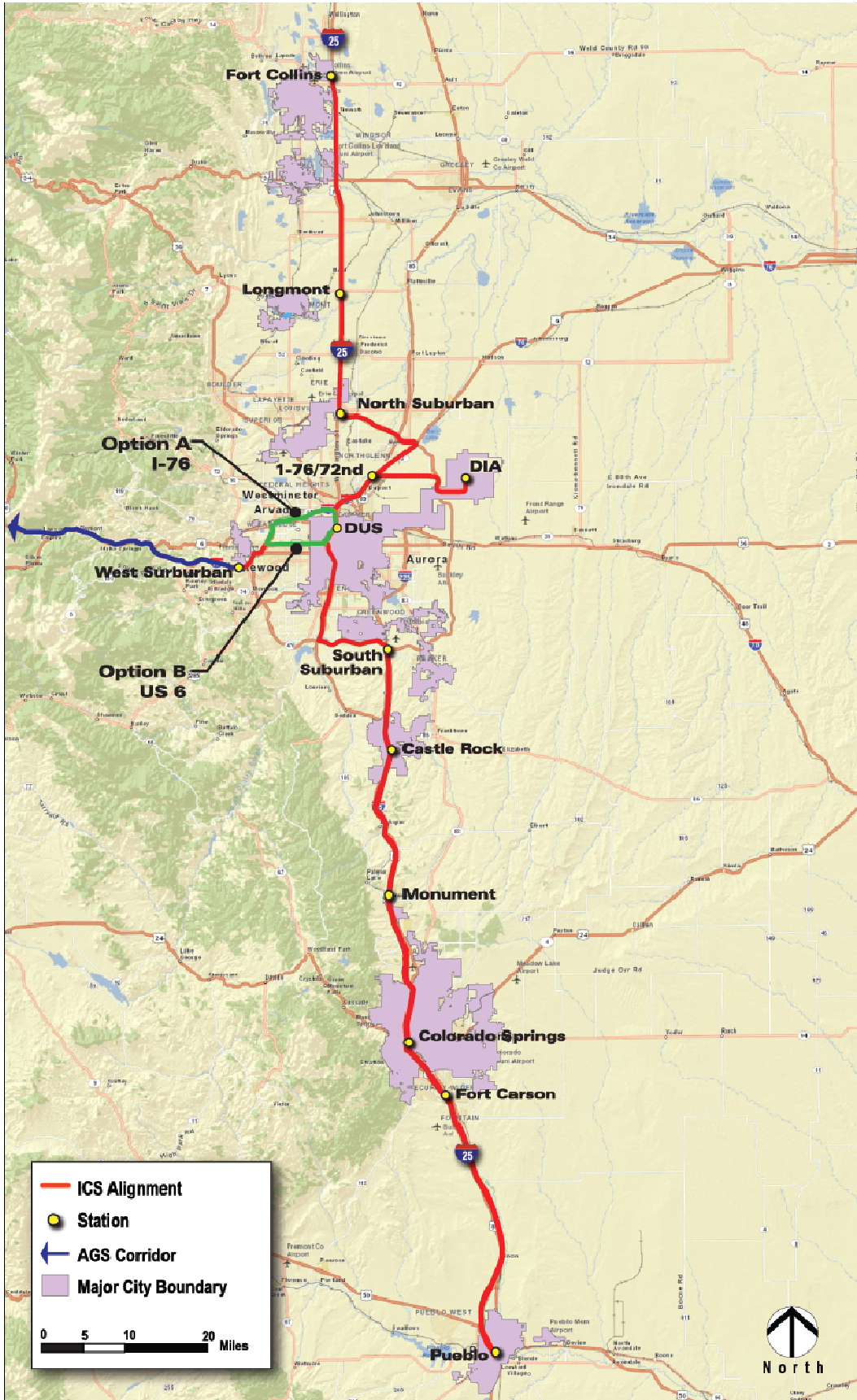

EXHIBIT 5-4: SCENARIO A-1: DIRECT ALIGNMENTS THROUGH DENVER



5.4.2 Scenario A-5: Eastern Beltway

The intent of this scenario is to test the effectiveness of traveling around the Denver metro area as opposed to using the railroad alignment (Segments NS-1 and NS-2) north to south through the Denver metro area as required with Scenario A-1. The east-west movements through the metro area are the same as discussed previously for Scenario A-1.

Scenario A-5 (also refer to Exhibit 5-5)

Technology

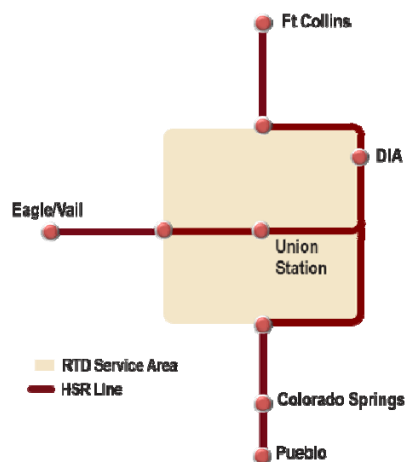

Both FRA compliant and non-compliant technologies are possible.

Alignment (See Exhibit 5-5)

East-to-West through Metro Denver

This scenario incorporates the same east-to-west design options (A and B) through the Denver metro area as presented for Scenario A-1.

North-to-South around Metro Denver

Starting from the North Suburban Station, the alignment travels to the east along the north side of E-470 and flies over Quebec Street, Riverdale Road, the South Platte River, and SH 285. It then travels on grade until it flies over SH 2, where it continues to follow along the east side of E-470 until it enters DIA property. From here, the alignment turns east, north of 78th Avenue, and parallels RTD's East Rail into the Airport Terminal.

From DIA, the alignment travels out of the Airport Terminal area west and then south, flying over Pena Boulevard, then back to grade for about 1,500 feet before it elevates again over E-470, alighting on the west side of the tollway traveling south. The alignment remains on the east side of the tollway,

flying over all east-west roadways and interchanges until it reaches South Parker Road, where it departs from the E-470 ROW for a short distance. It then flies over South Parker Road traveling west, and remains elevated to fly over E-470 to the south and west to the C-470/I-25 interchange. The alignment then turns south, aligned on the east side of I-25 to the South Suburban Station.

North to Fort Collins

The two alignment options traveling north to Fort Collins are the same as those described previously for Scenario A-1.

South to Pueblo

The alignment option traveling south to Colorado Springs and Pueblo is the same as that described for Scenario A-1.

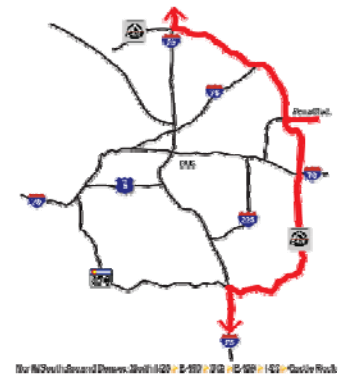

Stations

The stations modeled for this scenario are the same as described above for Scenario A-1.

Operating Strategy

The headways and hours of service for operation are the same as described for Scenario A-1.

This operating concept provides a single north-south pattern from Fort Collins to Pueblo via E-470 and I-25. The east-west pattern proceeds from DIA west to either Eagle County Regional Airport or Breckenridge, either via I-76 (A-5A) or US-6 (A-5B) in the same configuration as described for Scenario A-1. Similar to A-1, when A-5 is paired with Option A (I-76), transferring from one high-speed train to another is achieved by taking the North Metro line between DUS and I-76/72nd. With Option B (US 6), transfers occur at DUS, which is more efficient and faster. The operating plan details for Scenario A-5 are given below in both narrative and schematic form:

- Fort Collins to Pueblo:** 24 round trips daily - Stations: Fort Collins, Berthoud, North Suburban, DIA, South Suburban, Castle Rock, Monument, Colorado Springs, Fort Carson, Pueblo

- **DIA to Eagle Airport:** 21 round trips daily - Stations: DIA, I-76/72nd (A-5A) or DUS (A-5B), West Suburban, Georgetown, Silverthorne, Vail, Eagle County Regional Airport
- **DIA to Breckenridge:** 3 round trips daily - Stations: DIA, I-76/72nd (A-5A) or DUS (A-5B), West Suburban, Georgetown, Silverthorne, Breckenridge

Concept A5
Eastern Beltway
Basic Frequency
Service Plan

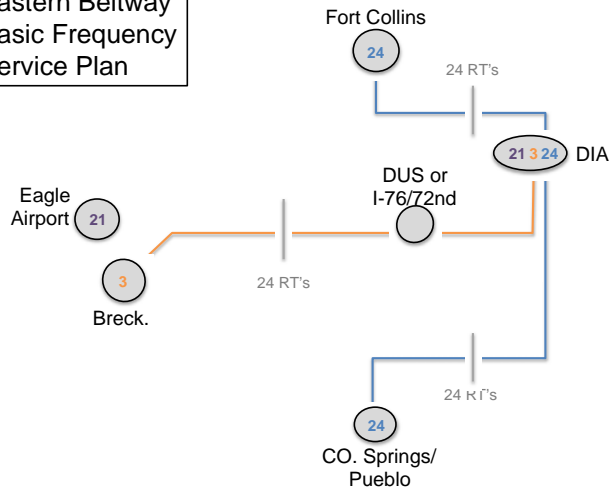

EXHIBIT 5-5: SCENARIO A-5: EASTERN BELTWAY



5.4.3 Scenario B-2A: Denver Periphery Excluding Northwest Quadrant

Scenario B-2A is configured to carry HST around the populated areas of the Denver metro area and rely on the RTD system to serve as a collector/distributor of transit patrons to and from the HST system.

Outside of the Denver metro area, this scenario is analogous to the other Level 2 scenarios.

Scenario B-2A (also refer to Exhibit 5-6)

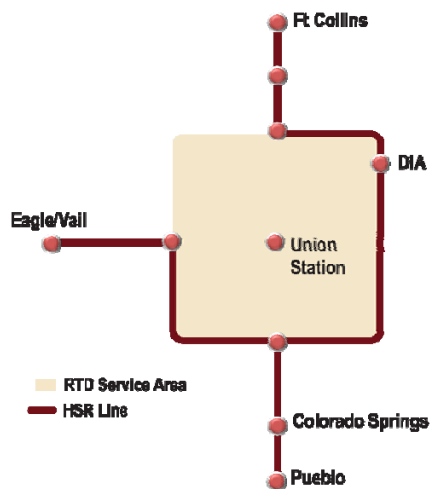

Technology

Outside of the Denver metro area, both FRA compliant and non-compliant vehicles could be used. Inside the RTD service area, RTD technologies would be used.

Alignment (See Exhibit 5-6)

The alignment for Scenario B-2A is the same as for Scenario A-5 with the exception that the C-470 beltway in the southwest quadrant is added. Unlike A-1 and A-5, there are no east-west alignments through the Denver metro area. The existing beltway serves as the east-to-west route.

North-to-South around Denver

The alignment around the Denver metro area from near I-25 north to DIA and from DIA to the South Suburban Station is the same as discussed for Scenario A-5.

Beltway around the Southwest Quadrant

From the West Suburban Station near the I-70 and C-470 interchange, the alignment proceeds at-grade south along the west ROW of C-470 and then flies over Alameda Parkway, Morrison Road, US 285, Quincy Avenue, Belleview Avenue, West Bowles Avenue, and Ken Caryl Avenue. From this point, it continues south along the C-470 ROW at-grade, then flies over Kipling Street and Wadsworth Avenue, and transitions to elevated structure over Santa Fe Avenue and the existing BNSF railroad corridor. The alignment transitions back to grade for a short distance, then elevates over Lucent Boulevard, Broadway Boulevard, University Boulevard, Colorado Boulevard, Quebec Street, and Yosemite Street, and finally over the C-470/I-25 interchange, terminating at the South Suburban Station east of I-25.

North to Fort Collins

The two alignment options traveling north to Fort Collins are the same as those described previously for Scenarios A-1 and A-5.

South to Pueblo

The alignment option traveling south to Colorado Springs and Pueblo is analogous to that described for Scenarios A-1 and A-5.

Stations

The stations modeled for this scenario are the same as those described for Scenarios A-1 and A-5, with one important exception: Scenario B-2A does not provide a station at DUS.

Operating Strategy

The headways and hours of service for operation of Scenario B-2A is the same as described for Scenarios A-1 and A-5.

Four different service patterns are defined, all using some portion of the beltway around the Denver metro area. The operating plan details for Scenario B-2A are given below in both narrative and schematic form:

- **Fort Collins to Pueblo:** 18 round trips daily - Stations: Fort Collins, Berthoud, North Suburban, DIA, South Suburban, Castle Rock, Monument, Colorado Springs, Fort Carson, Pueblo

- **DIA to Eagle Airport:** 12 round trips daily -
Stations: DIA, South Suburban, West Suburban, Georgetown, Silverthorne, Vail, Eagle County Regional Airport
- **Fort Collins to Breckenridge:** 6 round trips daily -
Stations: Fort Collins, Berthoud, North Suburban, DIA, South Suburban, West Suburban, Georgetown, Silverthorne, Breckenridge
- **Pueblo to Eagle Airport:** 6 round trips daily -
Stations: Pueblo, Fort Carson, Colorado Springs, Monument, Castle Rock, South Suburban, West Suburban, Georgetown, Silverthorne, Vail, Eagle Airport

Resulting trunk service levels are 24 round trips for the Basic Service Plan consistent with service levels defined for Scenarios A-1 and A-5.

Transfers between HST lines can occur at the North Suburban, DIA, South Suburban, and West Suburban stations.

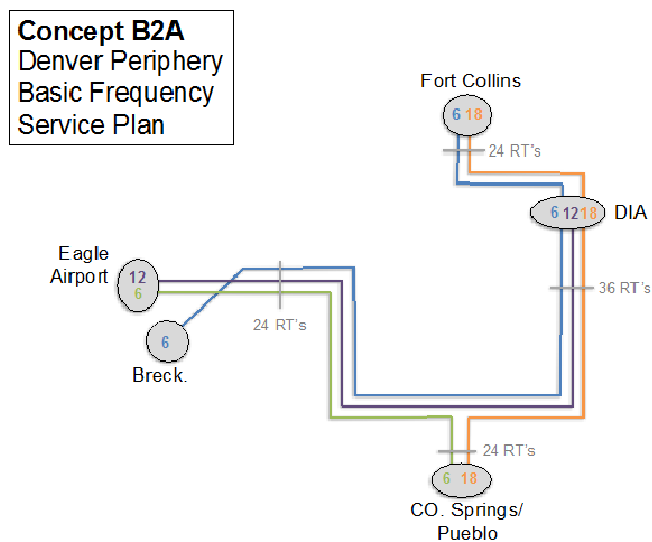
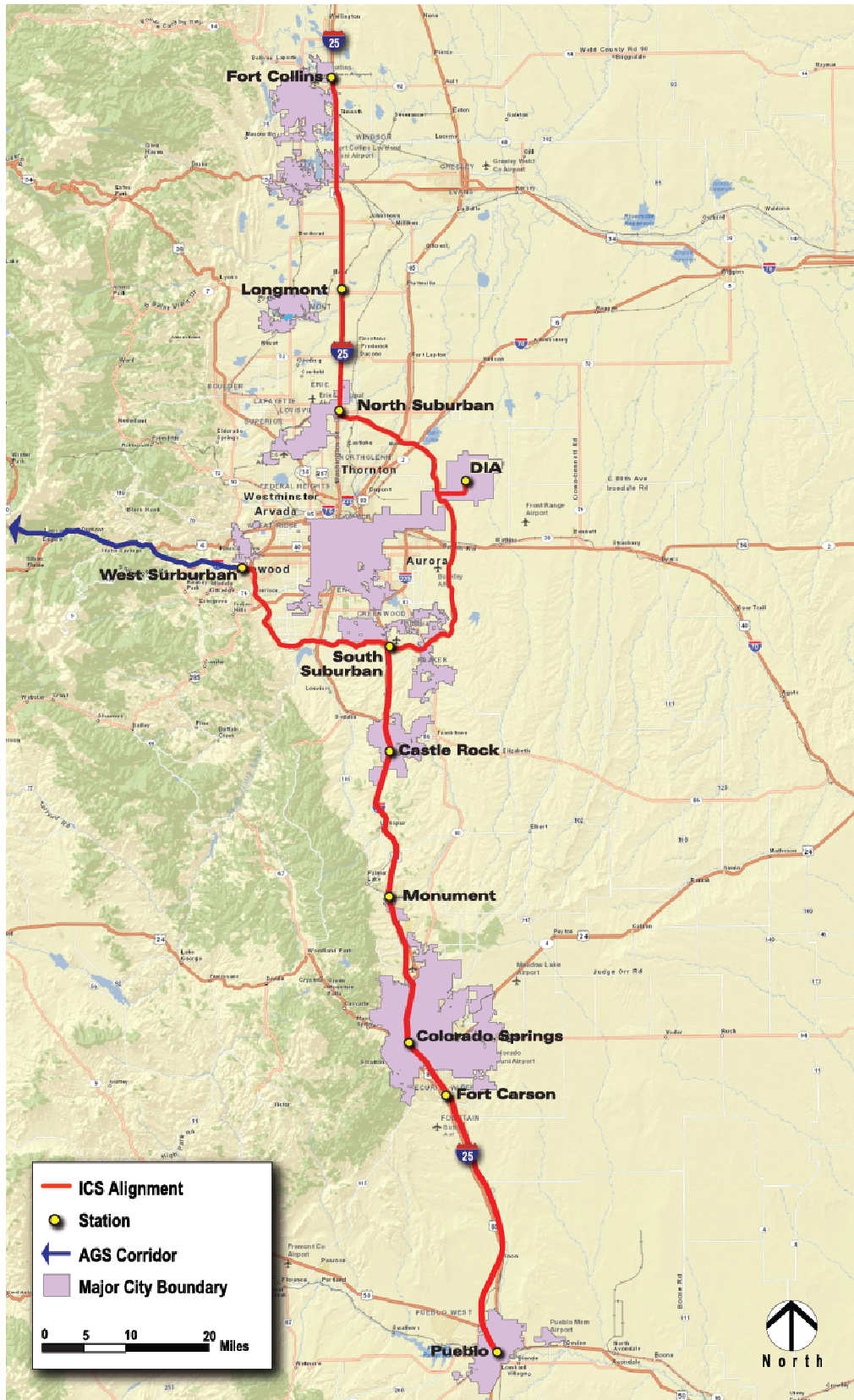

EXHIBIT 5-6: SCENARIO B-2A: DENVER PERIPHERY EXCLUDING NORTHWEST QUADRANT



5.4.4 Scenario B-5: Denver Periphery Excluding the Southwest Quadrant

Similar to Scenario B-2A, Scenario B-5 is configured to carry HST around the populated areas of the Denver metro area and relies on the RTD system to serve as a collector/distributor of transit patrons to and from the HST system. However, Scenario B-5 tests the differences in ridership and environmental impact by traveling across the northwest quadrant of the Denver metro area compared to the southwest quadrant for Scenario B-2A.

Outside of the Denver metro area, this scenario is analogous to the other Level 2 scenarios.

Scenario B-5 (also refer to Exhibit 5-7)

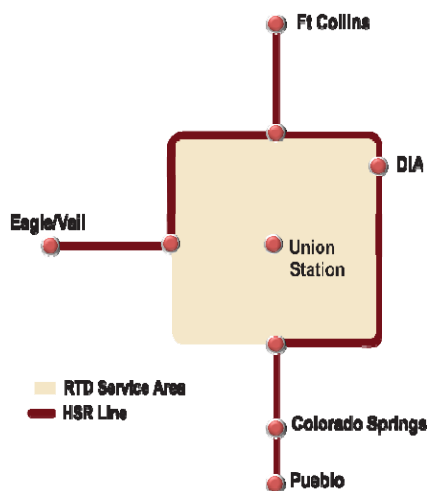

Technology

Outside of the Denver metro area, both FRA compliant and non-compliant vehicles could be used. Inside the RTD service area, RTD technologies would be used.

Alignment (See Exhibit 5-7)

The only alignment for Scenario B-5 that has not been discussed for the previous scenarios is the Northwest Quadrant, as described below.

West Suburban Station to North Suburban Station

From the West Suburban Station near the I-70/C-470 interchange, this alignment proceeds north along the west side of US 6 on a combination of at-grade, retained fill, and elevated structure until it reaches SH 58. The alignment flies over SH 58, then follows the west ROW of SH 93 to just south of Indian Head Road, where it flies over SH 93 to the south side of West 82nd Avenue. The alignment follows and

crosses 82nd Avenue just west of Indiana Street. From this point, the alignment travels north and parallel to Indiana Street, then proceeds to the northeast where it flies over SH 128 at Simms Street. It continues on elevated structure to cross to the east side of Interlocken Loop and over Eldorado Boulevard, Environmental Way, Interlocken Boulevard, and East Flatirons Crossing. It then flies over US 36 and onto the south side of Northwest Parkway. The alignment follows the tollway to and over I-25 and east to the North Suburban Station.

North Suburban Station to DIA

The alignment from the North Suburban Station to DIA is analogous to that described for Scenarios A-5 and B-2A.

DIA to the South Suburban Station

The alignment from DIA to the South Suburban Station is analogous to that described for Scenarios A-5 and B-2A.

North to Fort Collins

The alignment options for Scenario B-5 is the same as those described for the previous scenarios.

South to Pueblo

The alignment option for Scenario B-5 is the same as that described for the previous scenarios.

Stations

The stations modeled for this Scenario B-5 are the same as those described above for Scenarios A-1 and A-5, with one exception: Scenario B-5 does not provide a station at DUS.

Operating Strategy

The headways and hours of service for operation of Scenario B-5 are the same as described above for Scenario A-1. The details of the Basic Service Plan are given in both narrative and schematic form below:

- **Fort Collins to Pueblo:** 18 round trips daily - Stations: Fort Collins, Berthoud, North Suburban, DIA, South Suburban, Castle Rock, Monument, Colorado Springs, Fort Carson, Pueblo
- **DIA to Eagle Airport:** 12 round trips daily - Stations: DIA, North Suburban, West Suburban, Georgetown, Silverthorne, Vail, Eagle County Regional Airport

- **Fort Collins to Eagle Airport:** 6 round trips daily - Stations: Fort Collins, Berthoud, North Suburban, West Suburban, Georgetown, Silverthorne, Vail, Eagle County Regional Airport
- **Pueblo to Breckenridge:** 6 round trips daily - Stations: Pueblo, Fort Carson, Colorado Springs, Monument, Castle Rock, South Suburban, DIA, North Suburban, West Suburban, Georgetown, Silverthorne, Breckenridge

Resulting trunk service levels are 24 round trips, consistent with basic service levels defined for Scenarios A-1 and A-5.

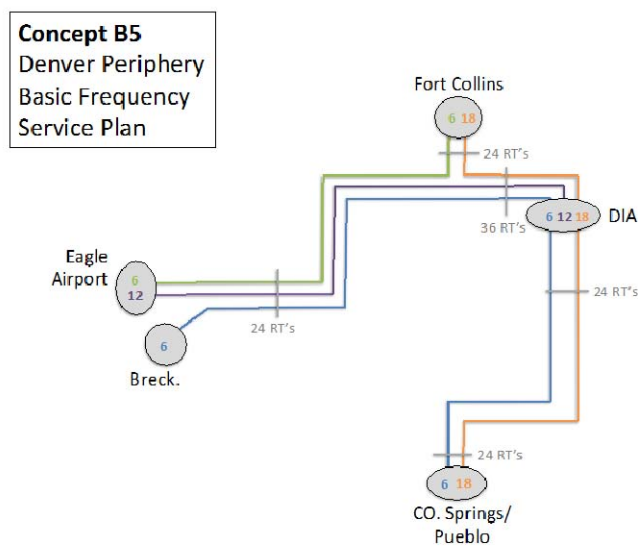
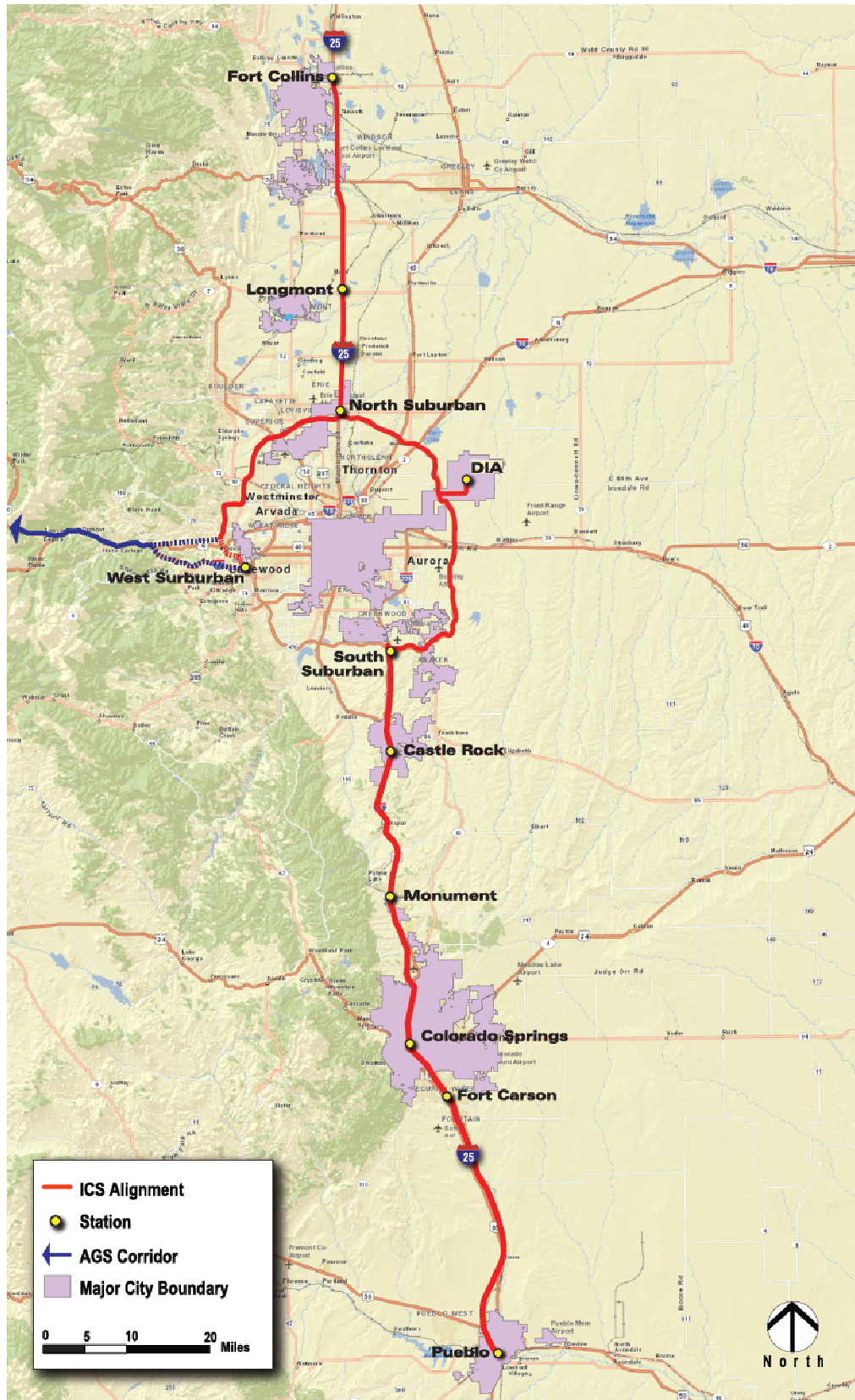

EXHIBIT 5-7: SCENARIO B-5: DENVER PERIPHERY NORTHWEST QUADRANT



5.4.5 Scenario C-1: Denver Periphery Shared Track with RTD

Scenario C-1 was modeled to test the effectiveness of using RTD's rail system to move patrons through the Denver metro area, connecting to the HST system. Shared track with the North Metro CRT to DUS from the North Suburban Station, the East Rail CRT from DIA to DUS, and the Gold Line CRT from DUS to the West Suburban Station is possible assuming an operating agreement that is acceptable to RTD and its Concessionaire. Because RTD's Southeast Corridor uses LRT vehicles that cannot run with FRA compliant technology, an independent alignment was provided along E-470 from DIA to the South Suburban Station.

Scenario C-1 (also refer to Exhibit 5-8)

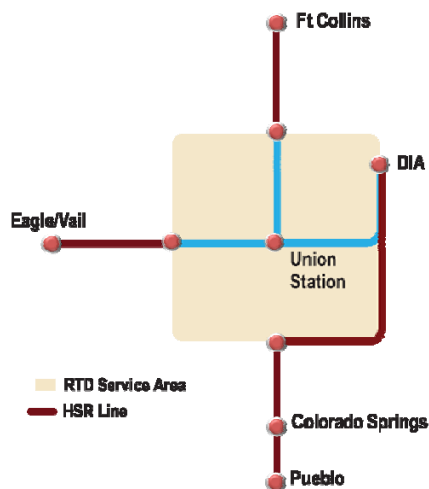

Technology

Scenario C-1 would require FRA compliant technologies for a one-seat ride. If a different technology were deployed for the I-70 mountain corridor, a transfer at the West Suburban Station would be required.

Alignment (See Exhibit 5-8)

Around Denver Metro Area

No new alignment would be provided around the Denver metro area except for the segment from DIA to the South Suburban Station, which is the same alignment along E-470 as described for Scenarios A-5, B-2A, and B-5.

North to Fort Collins

The alignment options north to Fort Collins for Scenario C-1 are the same as those described previously for the other scenarios.

South to Pueblo

The alignment option south to Pueblo for Scenario C-1 is the same as that described previously for the other scenarios.

Stations

The stations modeled for Scenario C-1 are the same as those described above for the previous scenarios. Access to DUS and DIA would be direct, with access provided by HST vehicles traveling on RTD-owned track.

Operating Strategy

Outside of the Denver metro area, the operating strategy for Scenario C-1 is generally the same as described above for the other scenarios.

Within the Denver metro area, the operating strategy is for HST to share track with RTD's Eagle project (East Rail and Gold Line) and the RTD North Metro Corridor. This would require negotiation of an operating window between the HST Authority and RTD and the use of FRA compliant technologies since both systems operate within freight rail corridors.

As mentioned above, HST could not operate on RTD's Southwest Corridor or Southeast Corridor since both systems use LRT, which is not FRA compliant. This would require the construction of a new alignment from DIA to the South Suburban Station along the E-470 ROW, described earlier. Specific service plan details are given below in both narrative and schematic form below:

- **Fort Collins to DUS:** 24 round trips daily - Stations: Fort Collins, Berthoud, North Suburban, DUS
- **DIA to Pueblo:** 24 round trips daily - Stations: DIA, South Suburban, Castle Rock, Monument, Colorado Springs, Fort Carson, Pueblo
- **DIA to Eagle Airport:** 21 round trips daily - Stations: DIA, DUS, West Suburban, Georgetown, Silverthorne, Vail, Eagle County Regional Airport
- **DIA to Breckenridge:** 3 round trips daily - Stations: DIA, DUS, West Suburban, Georgetown, Silverthorne, Breckenridge

Concept C1
Shared Track with RTD
Basic Frequency
Service Plan

----- = Shared Track with RTD

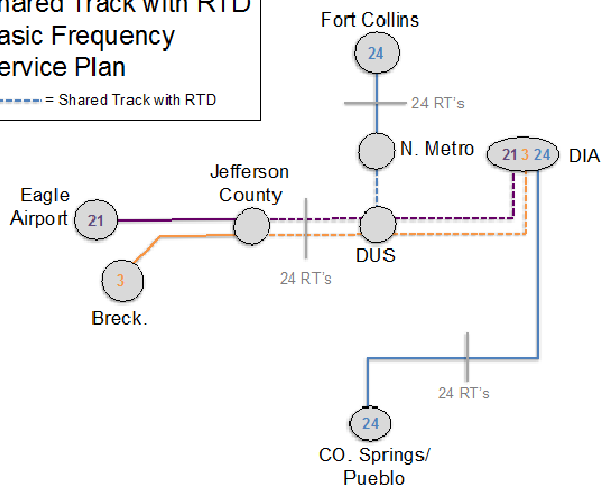
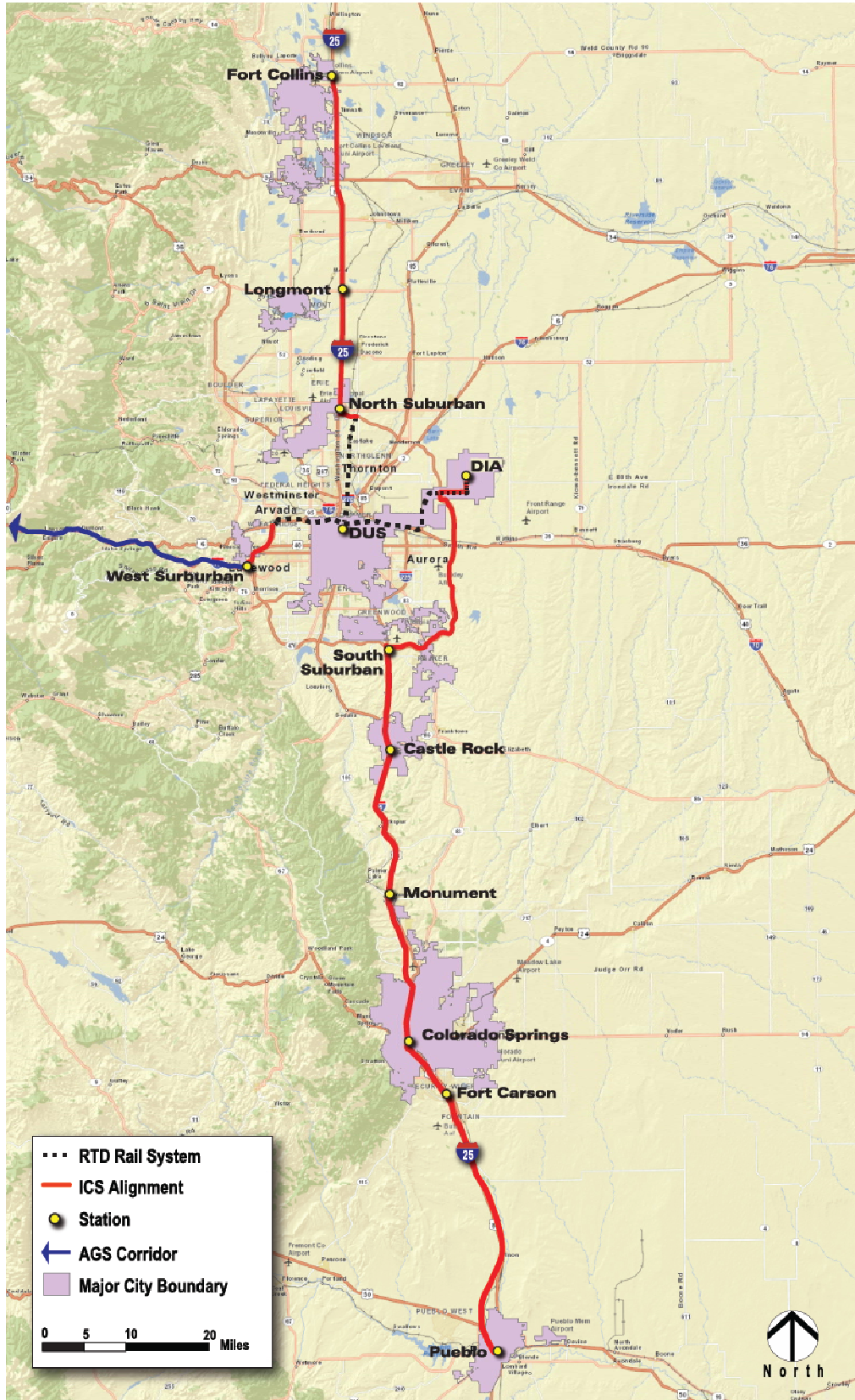

EXHIBIT 5-8: SCENARIO C-1: SHARED TRACK WITH RTD



Vital statistics for all of the scenarios are presented in **Exhibit 5-9**. This information shows that, in the big picture, the scenarios are similar with respect to miles of alignment, acres required, number of stations, and support facilities.

EXHIBIT 5-9: LEVEL 2 VITAL STATISTICS

		A-1		A-5		B-2A	B-5	C-1
		Option A (I-76)	Option B (US 6)	Option A (I-76)	Option B (US 6)			
Total Cost (ICS)		\$ 15.3 B	\$ 14.9 B	\$ 14.1 B	\$ 14.3 B	\$ 13.4 B	\$ 13.9 B	\$ 11.5 B
Corridor Length		219.4 miles	208.6 miles	214.7 miles	215.4 miles	208.4 miles	215.5 miles	172.6 miles
Right of Way	Alignment Acreage	1,267 acres	1,135 acres	1,135 acres	1,114 acres	981 acres	1,226 acres	904 acres
	Station & Facility Acreage²	320 acres	310 acres	270 acres	285 acres	260 acres	270 acres	250 acres
	Total Acreage	1,587 acres	1,445 acres	1,405 acres	1,399 acres	1,241 acres	1,496 acres	1,154 acres
Track and Structures	Miles at-Grade	119.3 miles	113.1 miles	120.7 miles	120.2 miles	113.3 miles	117.1 miles	97.4 miles
	Miles on Retained Fill	46.2 miles	42.5 miles	47.8 miles	47.2 miles	50.7 miles	55.3 miles	38.2 miles
	Miles Elevated	51.9 miles	51.0 miles	42.6 miles	44.3 miles	41.2 miles	39.5 miles	35.3 miles
	Miles in Retained Cut	1.4 miles	1.4 miles	2.7 miles	2.7 miles	2.3 miles	2.7 miles	1.3 miles
	Miles in Cut and Cover Tunnel	0.6 mile	0.6 mile	0.9 mile	1.0 mile	0.9 mile	0.9 mile	0.4 mile
	Miles in Bored Tunnel	0.0 mile	0.0 mile	0.0 mile	0.0 mile	0.0 mile	0.0 mile	0.0 miles
Stations	Primary	5 each	5 each	4 each	5 each	4 each	4 each	4 each
	Secondary	7 each	6 each	7 each	6 each	6 each	7 each	5 each
Support Facilities	Maintenance Facilities	2 each	2 each	1 each	1 each	1 each	1 each	1 each
	Layover Facilities	3 each	3 each	4 each	4 each	4 each	4 each	4 each

5.5 Evaluation of Level 2 Scenarios

This section presents the findings of the Level 2 Evaluation for the remaining five scenarios and associated design options.

5.5.1 Level 2 Evaluation Criteria

The criteria used to evaluate the scenarios were presented earlier in **Exhibit 3-3**. Further detail is shown in the matrix evaluation included in Appendix A, Level 1 and 2 Evaluation Matrices.

The Level 2 Evaluation findings for each of the principle criteria are summarized below:

- Public Benefits
- Transportation Benefits
- Environmental Issues
- Engineering Feasibility
- Operations and Maintenance Costs
- Planning Feasibility
- Benefit/Cost Analysis
- Financial Considerations

For each evaluation, only the criteria that serve as discriminators are discussed. For a full discussion, refer to Appendix A, Level 1 and 2 Evaluation Matrices.

5.5.2 Public Benefits

Evaluation of the Public Benefits criterion at Level 2 focused on how well each scenario addressed:

- The project Purpose and Need
- The level of public and agency support

Project Purpose and Need

At this level of evaluation, all of the scenarios fulfill the elements of the ICS Purpose and Need Statement. A key element of the ICS Purpose and Need is that the HST ***offers statewide social, environmental, and economic benefits that are greater than the capital and operating costs of its implementation***. All of the final five scenarios have benefit/cost ratios of about 2.0, meaning that for every dollar invested, two dollars are returned. Likewise, all five scenarios have operating ratios of greater than 1.0, and most are in the range of 1.2 to 1.3.

Public and PLT Support

Public support for HST appears to be positive statewide, but funding of the system presents concerns. In general, support has been strong based on PLT and public workshop processes. That said, the scenarios that travel around the Denver metro area (B-2A and B-5) appear to be better supported than those that traverse the urban area (A-1 and A-5). Because the alignments for all of the scenarios are the same once they leave the Denver metro area, there is no public preference.

Public Workshops

The following public input was received at the Level 2 Evaluation public workshops:

- **Fort Collins Area** – Many Fort Collins area residents have a strong interest in maintaining the vision established by the North I-25 EIS. The EIS recommended commuter rail transit (CRT) on the SH 287 alignment, with direct service to Longmont, Berthoud, Loveland, and Fort Collins. HST located on the I-25 alignment fulfills different objectives than the CRT, with a focus on intercity travel. However, so long as the HST does not eliminate the concept of CRT along the SH 287 corridor, it appeared to be well supported. The public suggested that perhaps the CRT system could function as a feeder system to the HST system. It was emphasized that there is a need to connect the HST more directly to the city centers along the route, either via a bus shuttle system or some other transit service.

If the HST were implemented, residents of Fort Collins and surrounding northern communities have stated a preference for the scenarios that follow E-470 to DIA (A-5, B-2A, and B-5) because the access is more direct and the travel times are faster. Access to DIA is considered more important than access west to the mountain communities. Additionally, several members of the public mentioned the desire to use the HST system to commute to downtown Denver.

- **Denver Area** – The reaction of Denver area residents to the five scenarios is mixed. Many recognize the benefit of avoiding the impacts of constructing HST through the Denver metro area, as required for Scenario A-1 and to a lesser extent Scenario A-5. Others are concerned that the scenarios that travel the beltways (B-2A and B-5) provide little direct access to the HST from urban

Denver. Some members of the PLT are concerned that omission of the DUS from the service plan will remove the economic benefits provided by HST. Other members of the PLT feel that any of the scenarios involving construction through the Denver metro area will not survive the NEPA environmental review process. There was no consensus on a preferred scenario at the public workshops or at PLT meetings.

- **Colorado Springs Area** – The public meetings in the Colorado Springs area suggest that the most significant concern revolves around an earlier segment (S-1) traveling through the Black Forest community. Once the alignment through Black Forest was eliminated at the conclusion of the Level 1 Evaluation, the residents’ previous concerns also were eliminated. Some members of the public expressed concern about the high cost of the HST. Based on the input, there is little support for a tax increase to fund an HST system.

Many believe that while 100 percent of the citizens would have to pay for the system, only a small percentage would use it. Feedback from both the public and the PLT indicated a preference for Scenario B-2A, assuming it could be funded. Others at the meeting suggested that providing rail service from Colorado Springs to Denver was the number one public transportation priority that has repeatedly surfaced in prior planning documents.

- **Pueblo Area** – Public meeting attendees in the Pueblo area were very supportive of HST. There was some concern that funding for the program would not be available in the near future. It was also suggested that the alignment through Pueblo should not be so constrained that it precludes expansion of the HST further south into New Mexico.
- **Mountain Corridor Area** – The mountain corridor residents and PLT members emphasized they do not want a conventional “steel wheel” HST program. There has been consistent insistence on an AGS featuring Maglev technology. There is concern that the scenarios proposed in the ICS may prevent the implementation of an AGS. This is especially true for Scenario C-1, which would require conventional FRA compliant technology

since it operates on existing and planned RTD track. Scenario A-1 with either Option A or B and Scenario A-5A are favored because they provide the most direct route to DIA. Scenario B-5 is also acceptable to this community. Residents of the mountain communities generally place lower importance on accessing DUS. There is much less preference for Scenario B-2A as it would direct travelers to the southern periphery of the Denver metro area en route to DIA.

5.5.3 Transportation Benefits

For the purpose of evaluation alternative scenarios in the Level 2 Evaluation, the assessment of Transportation Benefits included the following:

- System ridership
- Travel times
- Impacts on freight
- Impacts on aviation

System Ridership

As described below, HST system ridership directly affects revenue, reductions in vehicle miles traveled (VMT), and vehicle hours of travel (VHT).

Ridership and Revenue

Assuming political and public support, HST system ridership is the most important criterion considered in this study. Ridership drives revenue generation and the B/C studies and potentially relieves congestion on the highway system. There is also a direct correlation between ridership and the reduction of automobile use, resulting in air quality improvements. **Exhibit 5-10** presents the results of the Level 2 ridership and revenue estimation studies.

- As shown on the exhibit, Scenarios B-2A and B-5 represent the highest ridership at 13.8 and 13.7 million per year, respectively. Scenario A-1B produces the highest revenue even though the ridership at 13.1 million per year is about 5 percent lower. This is due to the difference in trip distribution and distance, and zone to station assignment.

EXHIBIT 5-10: AGS AND ICS ANNUAL RIDERSHIP, REVENUE, VEHICLE MILES TRAVELED, AND REDUCTION IN HOURS OF TRAVEL BY SCENARIO

Scenario	Ridership in Millions/Year	Revenue in Millions/Year	Reduction in Vehicles Miles Traveled	Reductions in Vehicle Hours of Travel (VHT)
A-1A	12,149,142	\$ 293,776,963	360,441,204	868,700
A-1B	13,162,834	\$ 323,101,495	395,965,041	1,233,382
A-5A	12,965,726	\$305,025,470	351,230,940	949,096
A-5B	13,137,458	\$306,777,970	351,361,395	992,042
B-2A	13,848,747	\$318,978,788	373,844,381	1,249,621
B-5	13,714,955	\$310,293,016	357,444,192	1,166,586
C-1	10,844,306	\$242,698,592	271,174,960	447,918

Scenario A-1B has longer-distance trips compared to Scenarios B-2A or B-5 because, in general, station-to-station distances are longer. Because the fares are calculated on a distance basis, longer trips mean higher fares, notwithstanding the decrease in ridership for Scenario A-1B compared to Scenarios B-2A or B-5.

- Scenario A-5B performs about the same as Scenario A-1B, with just under 13.2 million riders per year. Although slightly lower at 12.9 million riders per year, Scenario A-5A performs nearly as well but does not provide direct access to DUS.
- Scenario A-1B performs better than Scenario A-1A due to a long transfer time between the 72nd Avenue Station and DUS.
- Scenario C-1 performs the poorest of the scenarios considered due to the much slower travel times on the RTD alignments. Nonetheless,

this scenario will likely serve as a component of any future phasing strategy for HST in Colorado.

Reduction in Vehicle Miles Traveled and Vehicle Hours of Travel

- VMT** - Reductions in VMT and VHT represent benefits to the public in terms of reduced air emissions and travel times, respectively. As shown on **Exhibit 5-10**, the results are not always intuitive. For example, the scenario with the highest ridership, B-2A, does not have the highest reduction in VMT, but is second behind Scenario A-1B. Scenario A-1A has the third highest reduction in VMT but the fifth highest ridership. Scenario B-5 has the second highest ridership but the fourth highest reduction in VMT.

The VMT reduction is the difference between the end-to-end automobile travel distance and the sum of the access/egress distances (when the auto trip is diverted to HST) divided by the vehicle

occupancy summed over all the person trips. In this instance, Scenario A-1B has longer distance rail trips in general (as described above), which means shorter distance access/egress trips to and from rail stations by auto. As a result, diversions to the HST from auto result, in general, in greater reductions in miles traveled and hence lower VMT.

- **VHT** – With respect to VHT, on the other hand, Scenario B-2A has the greatest reduction, followed by Scenarios A-1B and B-5.

VHT reduction is the difference between the end-to-end travel time with the auto mode and the HST mode (when the auto trip is diverted to HST and includes the access/egress time by auto to and from the rail station, any transfer time, terminal times, and the HST line haul times) divided by the vehicle occupancy (to get vehicle level statistics) summed over all the person trips.

Because Scenario B-2A provides, in general, lower end-to-end travel times (and hence higher ridership) with the HST option compared to Scenario A-1B, the VHT reduction is higher for B-2A (and disproportionately lower for B-5) compared to A-1B even though it is the opposite for the VMT reduction. The main reasons that the end-to-end travel time is lower for Scenario B-2A or B-5 is the shorter or no transfer times and shorter station-to-station times in many cases. The short station-to-station time is due to the reassignment of stations; for example, a DUS to Eagle County trip may now be a Suburban West to Eagle County trip. Therefore, even though the auto access/egress times to and from the HST stations may be higher for Scenario B-2A or B-5 compared to Scenario A-1B, the travel time decreases related to HST more than offset the access/egress time increases in general.

Distribution of Ridership

Of the total system ridership, approximately 80 percent represent intercity trips, with the remaining trips occurring within the Denver metro area. Overall, as discussed in more detail below, the average split of riders is 18 percent I-70 mountain corridor, 18 percent I-25 north, 43 percent I-25 south, and 20 percent Denver metro area.

Impact on Mountain Corridor Ridership (I-70)

A review of **Exhibit 5-11** shows that the distribution of riders traveling to the mountains ranges from about

16 to nearly 22 percent, with the average of all scenarios being 18 percent. The highest ridership to the mountains is with Scenarios B-2A and B-5, with 21.6 and 20.4 percent, respectively; Scenarios A-1B and A-5A are close behind at about 19 percent each. The lowest ridership to the mountains is with Scenario C-1, at 15.6 percent, which is due to the slow travel times through metro Denver resulting from operations on shared RTD track.

Exhibits 5-12 through 5-18 provide a graphical display of the scenarios, showing which scenarios provide the best inter-regional and intra-regional ridership to the different markets. As discussed above, Scenarios B-2A and B-5 provide the highest inter-regional ridership to the mountains. These scenarios also provide the highest intra-regional ridership within the I-70 corridor, at 1.65 million riders per year. However, these scenarios provide the lowest ridership between the mountain corridor and downtown Denver. The highest ridership between the mountain corridor and Denver is with Scenarios A-1B and A-5B at 1.23 million riders per year (see **Exhibits 5-13 and 5-15**).

Impact on North Ridership (I-25)

Ridership to the north and Fort Collins averages 18 percent of the total (see **Exhibit 5-11**). With 22.7 percent of the total, Scenario B-5 realizes the highest ridership due to its broad access across the northern Denver metro area. The lowest ridership traveling north is represented by Scenario C-1 because of the need to travel to DUS on the RTD East Rail, than transfer to the RTD North Metro alignment heading north.

While Scenario B-5 provides the highest inter-regional ridership to the north, Scenario A-1B provides the highest inter-regional ridership between the north and south corridors, at 1.15 million riders per year. Scenarios A-5B, B-2A, B-5, and C-1 provide equal intra-regional ridership within the I-25 north corridor, at 820,000 riders per year.

Exhibits 5-12 through 5-18 provide a graphical representation of ridership by market.

Impact on South Ridership (I-25)

The largest volumes of HST riders travel south, generally averaging 43 percent of the total (see **Exhibit 5-11**). The highest ridership, 6,220,862, is realized with Scenario B-2A. This is because the alignment provides strong access to both the mountains and north to DIA and Fort Collins. The highest percentage, 46 percent, is realized with

EXHIBIT 5-11: AGS AND ICS DISTRIBUTION OF RIDERSHIP BY SCENARIO





Scenario	A-1A	A-1B	A-5A	A-5B	B-2A	B-5	C-1
Ridership							
Mountains							
Annual	2,168,094	2,516,754	2,430,662	2,136,961	2,995,866	2,792,520	1,696,330
Daily	7,227	8,389	8,102	7,123	9,986	9,308	5,654
Percent of Scenario Total	17.85%	19.12%	18.75%	16.27%	21.63%	20.36%	15.64%
North of Denver							
Annual	2,069,642	2,472,297	2,326,763	2,620,094	2,498,178	3,107,216	1,909,081
Daily	6,899	8,241	7,756	8,734	8,327	10,357	6,364
Percent of Scenario Total	17.04%	18.78%	17.95%	19.94%	18.04%	22.66%	17.60%
South of Denver							
Annual	5,451,251	5,674,676	5,584,849	5,514,986	6,220,862	5,596,993	4,994,421
Daily	18,171	18,916	18,616	18,383	20,736	18,657	16,648
Percent of Scenario Total	44.87%	43.11%	43.07%	41.98%	44.92%	40.81%	46.06%
Denver Metro							
Annual	2,460,154	2,499,106	2,623,452	2,865,417	2,133,840	2,218,226	2,244,474
Daily	8,201	8,330	8,745	9,551	7,113	7,394	7,482
Percent of Scenario Total	20.25%	18.99%	20.23%	21.81%	15.41%	16.17%	20.70%
Total	12,149,141	13,162,833	12,965,726	13,137,458	13,848,747	13,714,955	10,844,306

EXHIBIT 5-12: SCENARIO A-1A RIDERSHIP

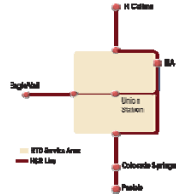
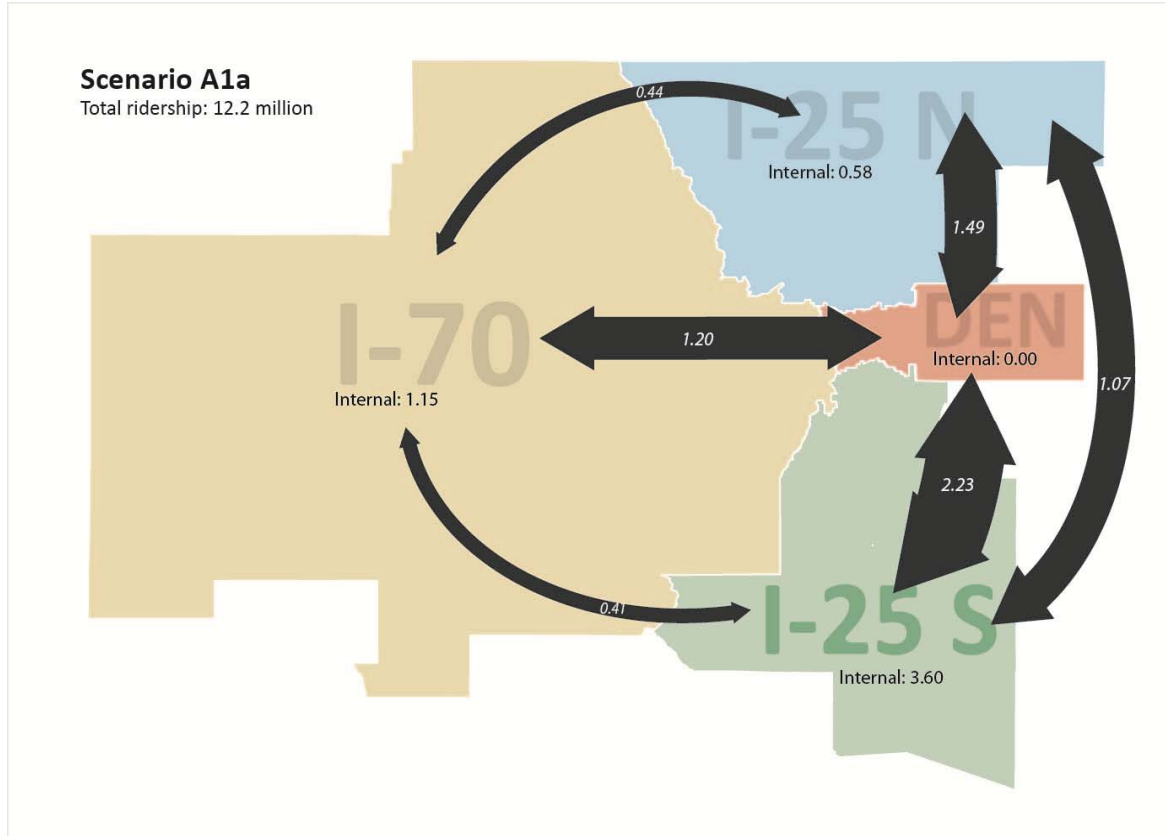

EXHIBIT 5-13: SCENARIO A-1B RIDERSHIP

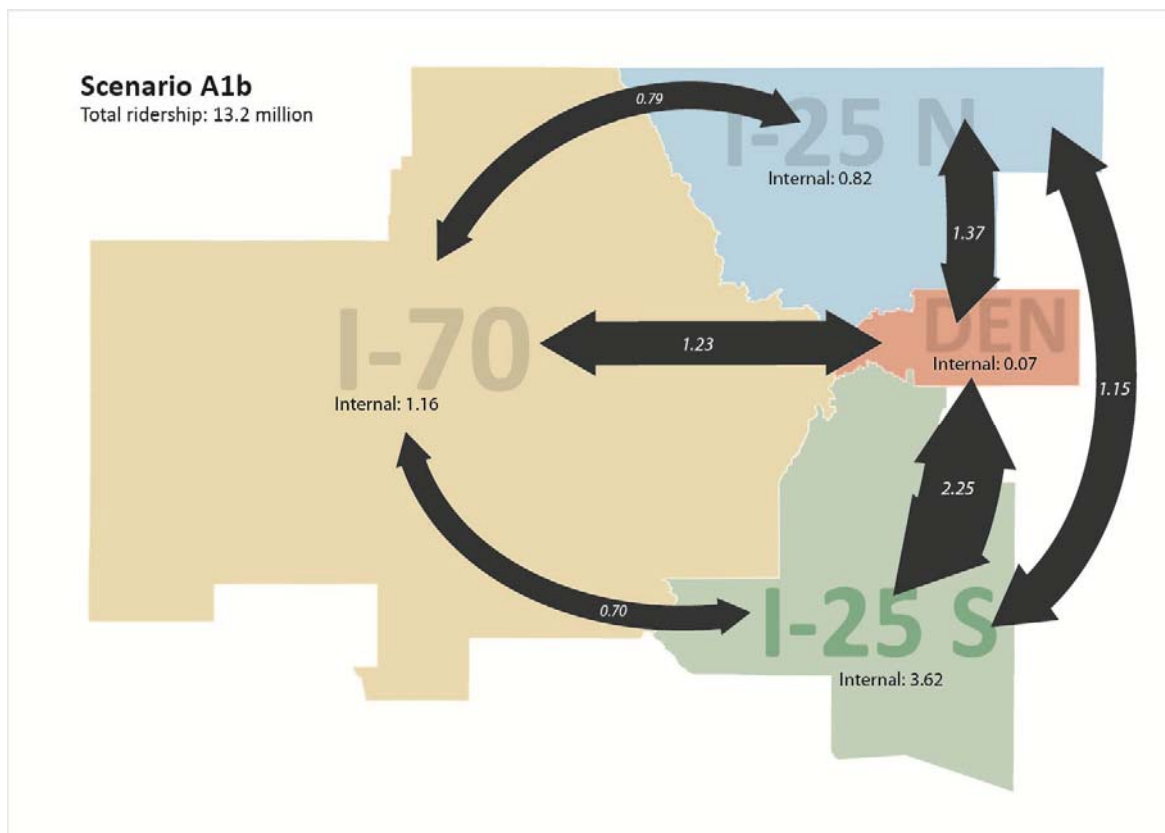

EXHIBIT 5-14: SCENARIO A-5A RIDERSHIP

Scenario A5a

Total ridership: 13.0 million

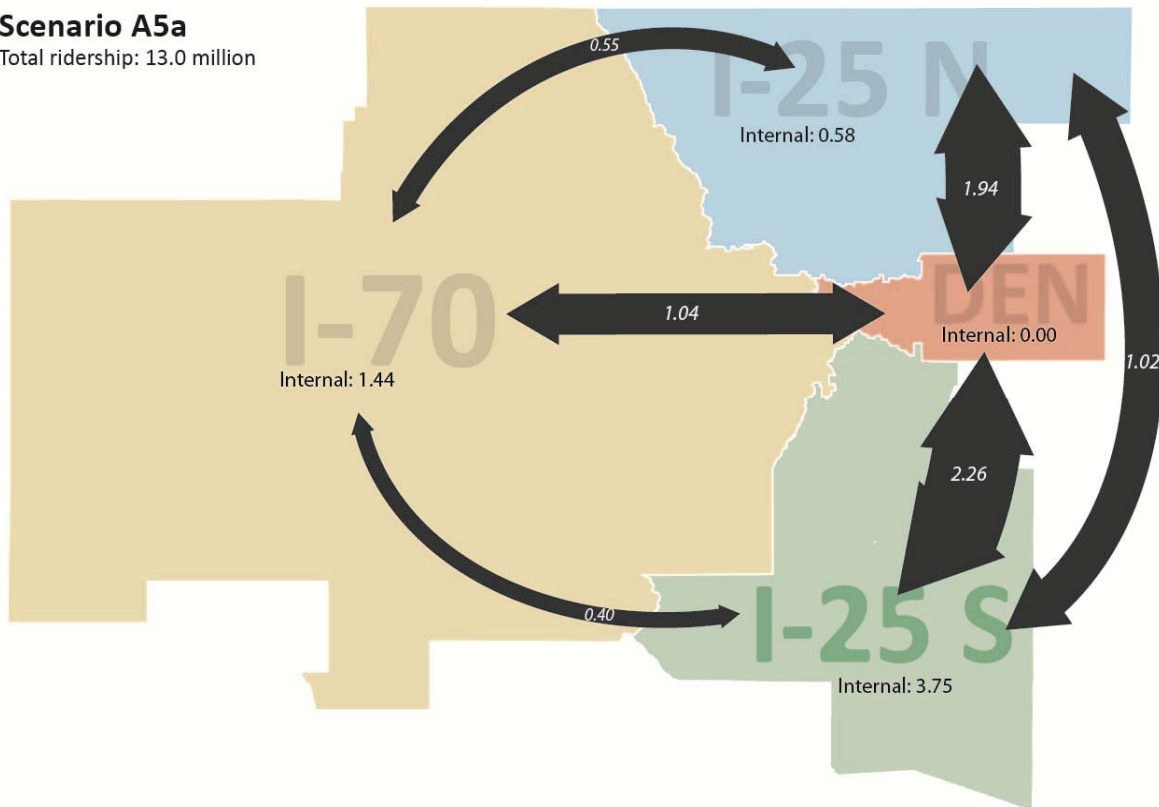

EXHIBIT 5-15: SCENARIO A-5B RIDERSHIP

Scenario A5b

Total ridership: 13.1 million

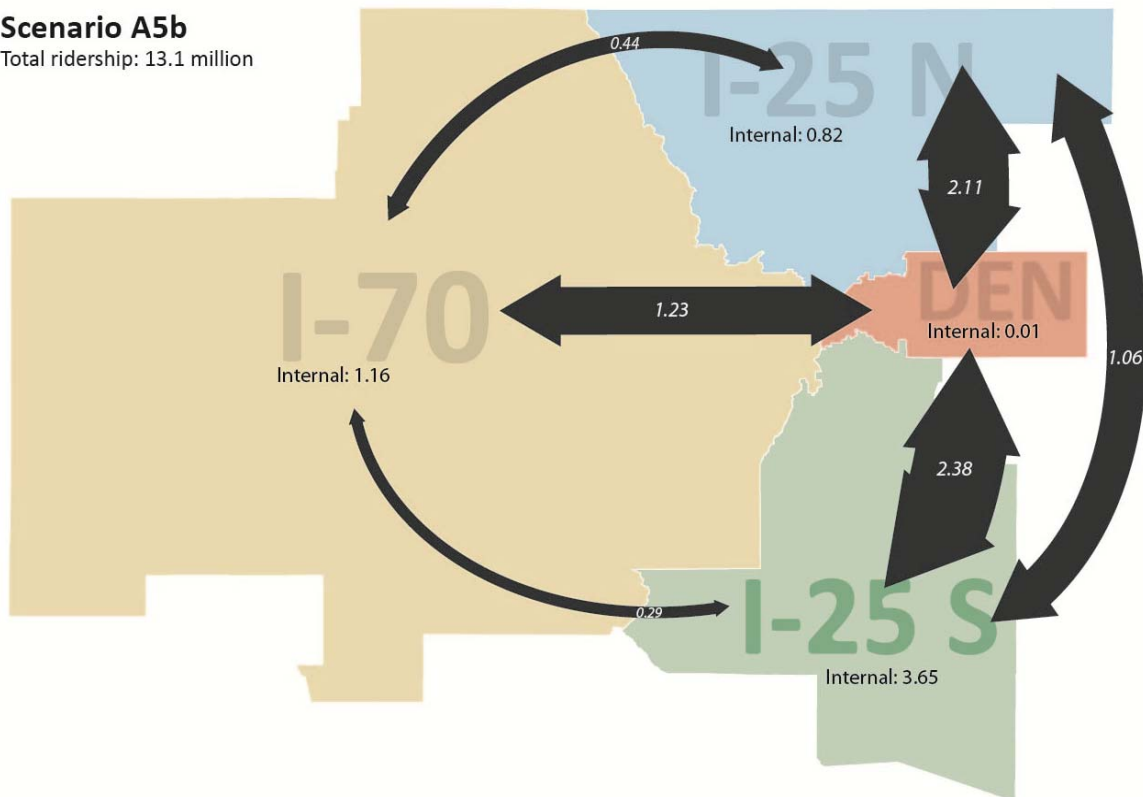

EXHIBIT 5-16: SCENARIO B-2A RIDERSHIP

Scenario B2a

Total ridership: 13.8 million

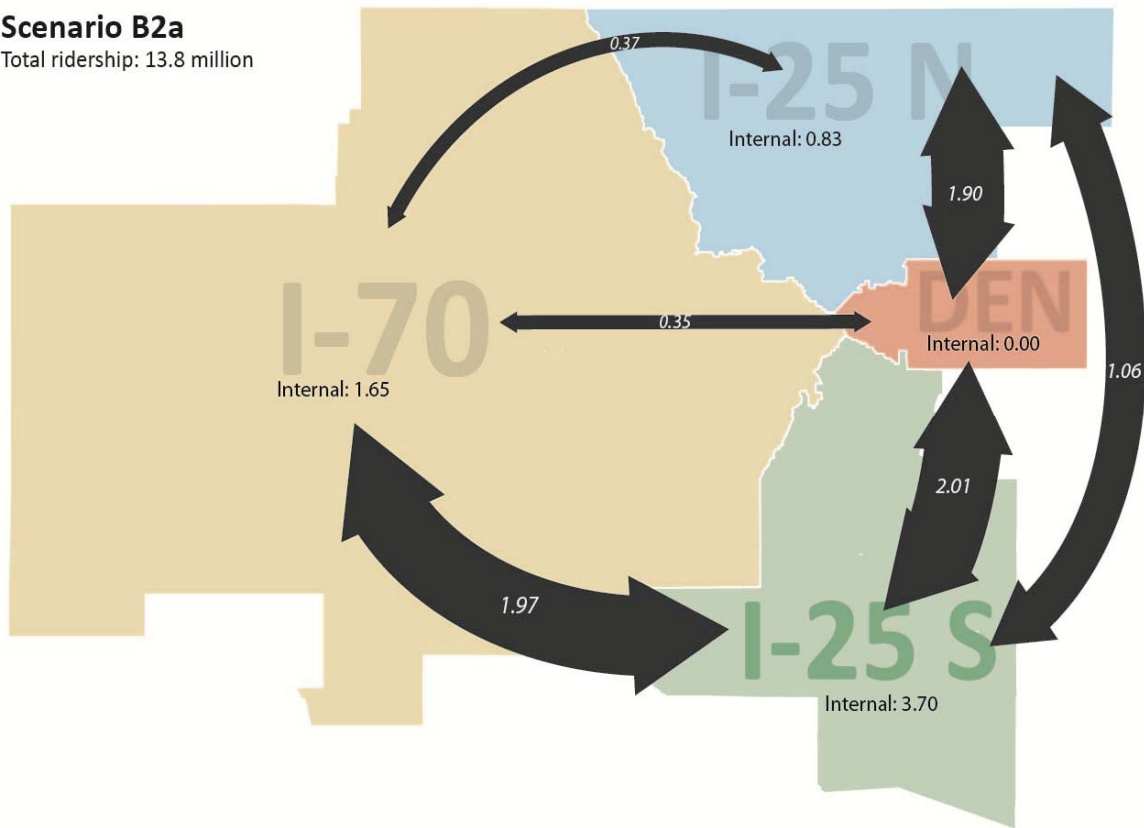

EXHIBIT 5-17: SCENARIO B-4 RIDERSHIP

Scenario B4

Total ridership: 13.7 million

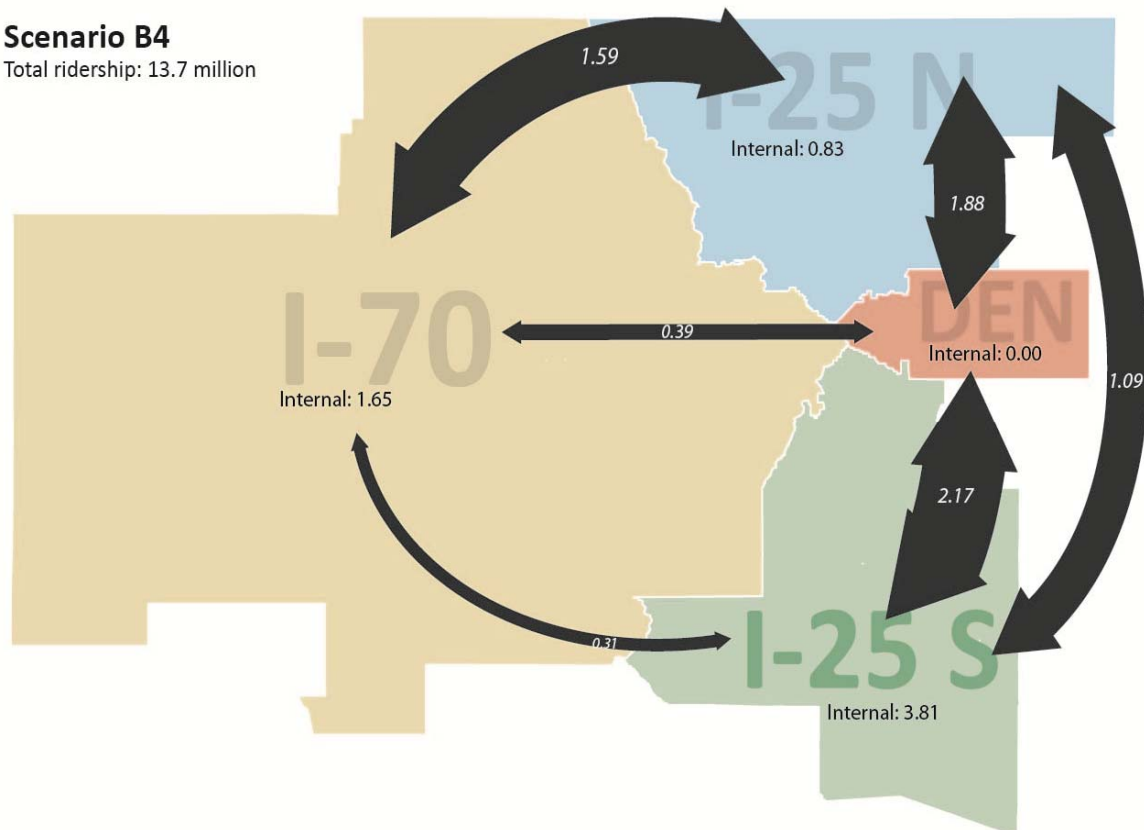
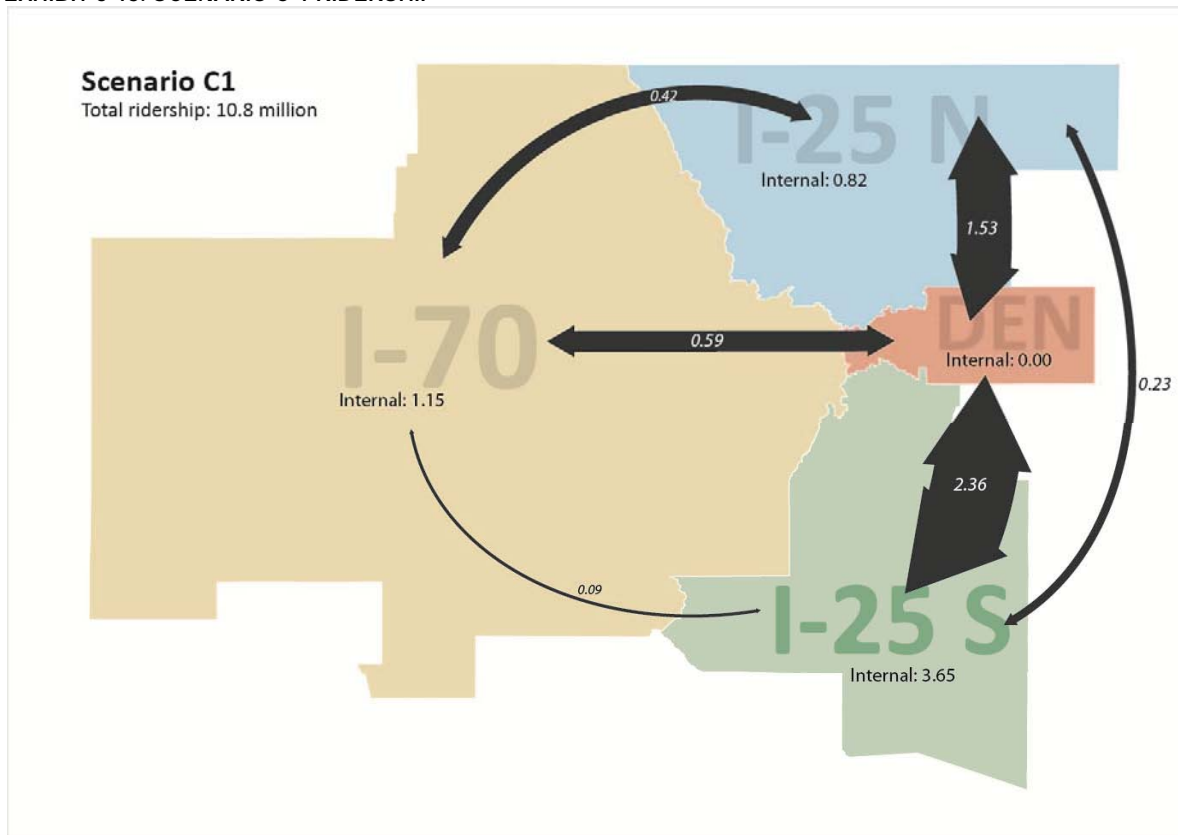

EXHIBIT 5-18: SCENARIO C-1 RIDERSHIP



Scenario C-1, due to the direct connection along E-470 to DIA. However, the absolute ridership, 4,994,421, is lower than for any of the other scenarios. The highest intra-regional ridership within the I-25 south corridor is provided by Scenario B-5 at 3.81 million riders per year (see **Exhibit 3-8**).

Exhibits 5-12 through 5-18 provide a graphical representation of ridership by market.

Impact on Denver Area Ridership

As stated above, the Denver metro area ridership averages about 20 percent (see **Exhibit 5-11**). The best ridership is provided by Scenario A-5A or Scenario A-5B, with 2,623,452 and 2,865,417 riders per year, respectively. The beltway scenarios, B-2A and B-5, generate the lowest ridership values, at 15 and 16 percent, respectively. The comparative absolute values are 2,133,840 and 2,218,226 per year.

To expand further on ridership between downtown Denver and the other corridors, Scenario A-5B provides the best ridership between Denver and the north corridor at 2.11 million riders, as well as the best ridership to the south corridor at 2.38 million riders per year. Scenarios A-1B and A-5B provide the

best ridership to the mountain corridor at 1.23 million riders per year. Within the Denver metro area, Scenario A-1B realizes the highest ridership at 70,000 riders per year due to the transfer between the I-76/72nd Station and DUS (see **Exhibit 5-13**).

Exhibits 5-12 through 5-18 provide a graphical representation of ridership by market.

Station Boarding

Exhibit 5-19 depicts station boarding by scenario, indicating that the major activity (defined as stations that have over 1 million riders per year) is located at the following stations:

- Fort Collins
- North Suburban
- DIA
- Denver Union Station
- South Suburban
- Castle Rock
- Colorado Springs

EXHIBIT 5-19: AGS AND ICS STATION BOARDINGS BY SCENARIO

Station	A-1A	A-1B	A-5A	A-5B	B-2A	B-5	C-1
Berthoud	386,992	422,349	357,393	366,126	312,573	452,567	282,497
Breckenridge	169,282	185,456	172,060	164,956	189,263	165,547	130,262
Castle Rock	945,886	985,272	1,072,147	1,062,746	1,034,161	1,083,894	1,014,947
Colorado Springs	1,298,310	1,357,422	1,265,060	1,259,533	1,478,361	1,245,389	1,128,475
Denver - I-76/72 nd	338,206	--	589,928	--	--	--	--
Denver - Union Station	1,463,284	1,621,610	--	732,198	--	--	956,729
DIA*	658,622	877,496	2,033,524	2,133,219	2,133,840	2,218,226	1,287,745
Eagle Airport	591,377	654,587	589,253	560,359	549,180	540,183	405,094
Fort Carson	475,121	496,857	473,112	474,407	545,265	470,728	425,272
Fort Collins	1,221,262	1,370,281	1,144,980	1,259,077	1,132,901	1,458,643	1,142,896
Georgetown	203,247	224,483	192,378	200,514	192,623	193,767	175,426
Silverthorne	260,455	303,484	275,999	268,138	301,124	281,059	204,453
South Suburban	1,295,597	1,348,359	1,415,994	1,346,603	1,566,632	1,448,317	1,200,321
Monument	677,197	709,043	617,278	620,451	794,024	599,633	512,214
North Suburban	469,738	679,667	832,686	994,891	1,052,705	1,196,005	483,687
Pueblo	767,052	777,723	749,154	751,246	802,418	749,034	713,192
West Suburban	579,968	726,573	811,194	560,457	1,364,369	1,238,402	502,542
Vail Station	369,594	422,171	395,604	382,537	399,307	373,561	278,553
Total	12,171,190	13,162,834	12,987,744	13,137,458	13,848,747	13,714,955	10,844,306

Busiest HST Stations

Fort Collins Station – This station realizes the highest boarding levels with Scenario B-5 at 1,458,643 riders per year, 29 percent higher than Scenario C-1, which has the lowest boardings at 1,142,896 riders per year. The second highest boardings at the Fort Collins Station is with Scenario A-1B, at 1,370,281 riders per year. The higher ridership experienced with Scenarios B-5 and A-1B is the result of slightly better access to HST provided by the alignment locations of these scenarios.

North Suburban Station – This station produces the highest ridership with Scenarios A-5B, B-2A, and B-5. This is due to the strong direct connections north and south that these scenarios provide. The lowest ridership is with Scenario C-1 due to the limited indirect connections north from DIA. Scenario A-1A also performs poorly for this station due to a long transfer at DUS.

DIA Station – The DIA station is the most dependent on the selection of a given scenario than any other station. The difference between the high and low ridership values is 237 percent. Scenarios A-5A, A-

5B, B-2A, and B-5 all generate over 2 million riders per year. Scenario A-1B produces the lowest ridership due to the east-west transfer required at DUS for riders traveling from the area north and south of the Denver metro area.

DUS Station – This station performs the best with Scenario A-1, with ridership ranging from 1,463,284 to 1,621,610, depending on the design option chosen. Option A (US 6) produces about 158,000 more annual riders than Option B (I-76), suggesting the importance of the direct north-south access provided by the CML freight rail alignment. Scenario C-1 produces 956,729 riders per year due to the direct connection between DIA and regions south. Scenario A-5B generates 732,198 riders per year. Scenarios A-5A, B-2A, and B-5 do not stop at DUS.

South Suburban Station – This station realizes high ridership with all the scenarios considered. The highest ridership is provided with Scenario B-2A, with 1,566,632 riders per year, due to the high level of access provided to the south, combined with high access to DIA and the north and direct routing to the mountain corridor.

Castle Rock Station – Like the South Suburban Station, this station realizes about 1 million riders per year with all scenarios. The ridership is high due to the volume of trips between Denver and Colorado Springs and the growing population in the Castle Rock area. The highest ridership is with Scenario B-5, generating 1,083,894 riders per year.

Colorado Springs Station – This station receives the highest ridership with Scenario B-2A, at 1,478,361 riders per year. This is due to the high levels of access to DIA and north to Fort Collins and the direct access to the mountain corridor provided by its beltway alignment. The other full-build scenarios produce annual ridership ranging from 1,245,389 to 1,357,422. Scenario C-1 produces the lowest annual ridership at 1,128,475 due to slower travel times to central Denver, the mountain corridor, and Fort Collins resulting from the use of shared RTD track.

Other Key Stations

As the end of line (EOL) stations, the Pueblo and Eagle County Regional Airport stations also merit discussion.

Pueblo Station – The Pueblo Station performs consistently at about 750,000 riders per year regardless of the scenario. This is largely attributed to being an EOL station. The ridership is the highest with Scenario B-2A because this alternative produces the highest absolute ridership and allows for direct access to the mountain communities, DIA, and Fort Collins.

Eagle County Regional Airport Station – The EOL station ridership is fairly consistent among the full-build scenarios, ranging from 540,183 riders per year for Scenario B-2A to 654,587 riders per year for Scenario A-1B.

Travel Times

Travel times are critical to the ridership success of each scenario. The following narrative presents the travel times from each major market.

Fort Collins Market

As shown in **Exhibit 5-20**, the travel time from Fort Collins to the North Suburban Station is the same for all scenarios. This is because all scenarios share the same alignment between the Fort Collins Station and the North Suburban Station. Scenarios A 5A, A-5B, B-2A, and B-5 all provide a travel time of 37 minutes to DIA because they share a common alignment along E-470 to DIA. Scenarios A 1A and A-1B produce a

much slower 1 hour 22 minute and 1 hour 14 minute travel time, respectively, to DIA because of the transfer requirements at I-76/72nd Avenue and DUS. The travel time for C-1 is slowest due to the reduced travel speeds required on the shared RTD track.

EXHIBIT 5-20: FORT COLLINS TO/FROM TRAVEL TIMES

	A-1A	A-1B	A-5A	A-5B	B-2A	B-5	C-1
North Suburban	0:23	0:23	0:23	0:23	0:23	0:23	0:23
DIA	1:22	1:14	0:37	0:37	0:37	0:37	1:41
Colorado Springs	1:33	1:33	1:34	1:34	1:34	1:34	2:59
Pueblo	2:00	2:00	2:01	2:01	2:01	2:01	3:26
Eagle Airport	2:55	2:47	3:01	3:01	2:52	2:26	3:09

Travel times from Fort Collins south to Colorado Springs and Pueblo are comparable for all of the full-build scenarios. Scenario C-1 has the longest travel time due to the reduced travel speeds required on the shared RTD track.

From Fort Collins to Eagle County Regional Airport, Scenario B-5 provides the fastest trip due to the direct routing of its alignments to the western markets. Scenario B-2A provides a slower travel time because of its indirect routing of passengers south along the beltways to the mountains. Again, Scenario C-1 is slowest because of the reduced travel speeds required on the shared RTD track.

Colorado Springs Market

As shown in **Exhibit 5-21**, the travel time from Colorado Springs to DIA is comparable at 55 minutes for all of the scenarios with the exception of A-1A and A-1B, which are slower due to the need to transfer at I-76/72nd Avenue and DUS.

EXHIBIT 5-21: COLORADO SPRINGS TO/FROM TRAVEL TIMES

	A-1A	A-1B	A-5A	A-5B	B-2A	B-5	C-1
DIA	1:34	1:26	0:55	0:55	0:55	0:55	0:55
Fort Collins	1:33	1:33	1:34	1:34	1:34	1:34	2:59
South Suburban	0:33	0:33	0:33	0:33	0:33	0:33	0:33
Pueblo	0:25	0:25	0:25	0:25	0:25	0:25	0:25
Eagle Airport	3:10	3:02	3:17	3:17	2:31	3:13	3:45

The trip to Fort Collins is similar for all scenarios except C-1, which is much slower due to the need to

transfer at DIA to DUS and then again at DUS to Fort Collins.

Travel to the South Suburban Station and to Pueblo is the same for all scenarios because the alignment is the same for all scenarios.

The best travel time to the mountain communities is provided by Scenario B-2A, which has direct access along C-470. All other scenarios provide similar travel times to Eagle County Regional Airport, with the exception of Scenario C-1, which has reduced travel speeds due to the shared RTD track. Scenario B-5 has a longer travel time to Eagle County Regional Airport than Scenario B-2A because travelers from the south follow an indirect route along the beltway segments to the east, then north and northwest before heading west to the mountains.

Pueblo Market

As shown in **Exhibit 5-22**, travel times from Pueblo to DIA are the same for Scenarios A-5A, A-5B, B-2A, B-5, and C-1 because the alignments all follow E-470 to the airport. Scenarios A-1A and A-1B are slower due to transfers required at I-76/72nd Avenue and DUS.

Travel times to Fort Collins are similar for all scenarios except C-1, which requires transfers at DIA and DUS due to the use of shared RTD track. Because all scenarios share the same alignment south, travel to the South Suburban Station and Colorado Springs is the same for each scenario.

Travel to the mountain communities is fastest with Scenario B-2A due to its direct routing. Scenario A-1B is the second fastest; although a direct route, it requires a transfer at DUS. Scenarios A-5A, A-5B, B-5, and C-1 are considerably slower due to out-of-direction routing.

EXHIBIT 5-22: PUEBLO TO/FROM TRAVEL TIMES

	A-1A	A-1B	A-5A	A-5B	B-2A	B-5	C-1
DIA	2:01	1:53	1:22	1:22	1:22	1:22	1:22
Fort Collins	2:00	2:00	2:01	2:01	2:01	2:01	3:26
South Suburban	1:00	1:00	1:00	1:00	1:00	1:00	1:00
Colorado Springs	0:25	0:25	0:25	0:25	0:25	0:25	0:25
Eagle Airport	3:37	3:29	3:46	3:46	2:58	3:40	4:12

Mountain Markets

As shown in **Exhibit 5-23**, the best travel times from Eagle County Regional Airport to DIA are provided by Scenarios A-1A, A-1B, A-5A, and A-5B as these have the most direct routes. The use of I-76 versus US 6 (Scenarios A-1A, A-1B, A-5A, and A-5B) makes little difference in travel time from the mountains to DIA. Scenarios B-2A and B-5 are comparable but longer distances than others due to the more circuitous routing. Scenario C-1 has the longest travel time due to the use of RTD shared track through metro Denver.

Travel time to the West Suburban Station is equal for all scenarios as they share a common alignment.

The shortest trip to Fort Collins is with Scenario B-5 as it provides the most direct route. Scenarios A-5A and A-5B provide long travel times to Fort Collins due to the transfer at DIA. The longest trip time is provided by C-1 due to slower travel times through metro Denver on the shared RTD track and a transfer at DUS.

The shortest travel times from the mountains to Colorado Springs and Pueblo is provided by Scenario B-2A because of its direct routing. Scenarios A-5A, A-5B, and B-5 are less direct since they route travelers out of direction to the E-470 alignment east of the Denver metro area before proceeding south. Scenario C-1 is the slowest because travelers need to transfer at DUS and DIA and because train speeds are slower on the RTD shared track.

EXHIBIT 5-23: EAGLE COUNTY REGIONAL AIRPORT TO/FROM TRAVEL TIMES

	A-1A	A-1B	A-5A	A-5B	B-2A	B-5	C-1
DIA	2:02	2:03	2:02	2:03	2:13	2:16	2:28
West Suburban	1:34	1:34	1:34	1:34	1:34	1:34	1:34
Fort Collins	2:55	2:47	2:59	2:59	2:52	2:26	3:09
Colorado Springs	3:10	3:02	3:17	3:17	2:31	3:13	3:45
Pueblo	3:37	3:29	3:46	3:46	2:58	3:40	4:12

Impacts on Freight

To allow the use of both FRA compliant and non-compliant technology, the scenarios for the Level 2 Evaluation have been configured to avoid freight railroads. Due to the design protocol, none of the scenarios would affect freight operations.

Impacts on Aviation

HST can often relieve congestion at airports in the same market area, resulting in the deferment of new airport expansion; however, that is not the case here. As shown on **Exhibit 5-24**, the volume of trip diversion to aviation is 4 to 6 percent. This is not sufficiently significant to defer investment in new construction at DIA, Eagle County Regional Airport, or Colorado Springs Airport.

EXHIBIT 5-24: IMPACT ON AVIATION BY SCENARIO

Scenario	Trip Type Breakdown		
	Intercity	Intra-Urban	Connect Air
A-1A (I-76)	84%	12%	4%
A-1B (US 6)	84%	12%	4%
A-5A (I-76)	75%	20%	5%
A-5B (US 6)	76%	19%	5%
B-2A	77%	19%	4%
B-5	75%	21%	4%
C-1	78%	16%	6%

5.5.4 Environmental Issues

The purpose of the Level 2 Evaluation is to ensure that environmental criteria are considered in the selection of a preferred scenario. More detailed environmental analysis that complies with NEPA and other federal, state, and local regulations will be required as the project moves toward implementation.

The Level 2 Evaluation used quantitative but broad measures to compare the scenarios. The environmental evaluation considered impacts to the following resource areas:

- Community disruption
- Park and recreation facilities
- Historic resources
- Environmental justice
- Wetlands and water resources, including stream crossings
- Air quality (benefits and impacts)
- Noise
- Energy and congestion (benefits and impacts)
- Land use and development effects, including TOD potential
- Initial and permanent employment changes
- Safety
- Hazardous waste

Environmental consequences associated with the Level 2 scenarios are presented for the following areas:

- ICS Study Area
- Denver Metro Area
- North of Denver Metro Area
- South of Denver Metro Area

ICS Study Area

With the exception of their configuration through the Denver metro area, the five scenarios (and two design options) are essentially the same. As major projects, construction of any of the scenarios is expected to create environmental impacts. On average, the full-build scenarios involve about 214 miles of guideway construction and, with stations, could require about 1,430 acres of property acquisition. Scenario C-1, which shares track with RTD in the Denver metro area, would disturb about 1,154 acres or about 276 fewer acres than the other full-build scenarios. Of the full-build scenarios, B-2A would have the smallest construction footprint, requiring about 87 more acres of disturbance than Scenario C-1. Further, the total construction footprint is probably not as important as the location of the impact. Under this assumption, the scenarios that travel through the Denver metro area (A-1A, A-1B, A-5A, and A-5B) are predicted to have a much greater impact than the scenarios that operate in the periphery (B-2A and B-5), as discussed below.

With respect to environmental benefits, the operation of all of the scenarios would encourage more compact development around the HST stations, thus reducing urban sprawl and encouraging the use of transit. Both of these benefits would reduce VMT, resulting in a modest positive impact on air quality. Because the ridership among the full-build scenarios differs only by about 6 percent, the relative differences in benefits are also modest.

Denver Metro Area

Potential environmental impacts of the different scenarios vary in the Denver metro area primarily because this is the most populated area within the state. Scenarios that travel directly through the Denver metro area (A-1A, A-1B, A-5A, and A-5B) have much greater community impacts than those that traverse around the metro area (B-2A and B-5). Scenario C-1 involves minimal construction within

the Denver metro area and thus has few construction impacts.

Alignments through the Denver Metro Area (Scenarios A-1A, A 1B, A-5A, and A-5B)

All of the alignments through metro Denver have the potential for adverse community and environmental impacts. High-speed trains moving through developed communities raise concerns over noise, vibration, and safety at crossings, as well as the visual impacts of tracks and guideways that are elevated to minimize ROW needs and avoid at-grade crossings with roads, trails, and other transit lines.

Based on the current alignments, average speeds through Denver would be approximately 100 to 110 mph, with top speeds in some stretches reaching 150 mph. The study team obtained input from communities about what speeds might be acceptable, and it is likely that the estimated speeds would be too high to be compatible with residential neighborhood settings. However, for the Level 2 Evaluation, speeds were modeled as fast as alignment curvature and grades would allow in order to improve travel times and ridership. Reductions in speeds would increase travel times, making it difficult for HST to be competitive with automobile travel times.

Additionally, insufficient ROW is available within transportation corridors in the Denver metro area in both highway and rail corridors. In some stretches, HST alignments can be located within the transportation corridors; however, in most locations, HST alignments must parallel the corridors and would require minimum adjacent ROW of about 60 feet. Constrained areas are present throughout all of the east-west and north-south alignments through metro Denver but are especially problematic along the east-west alignments (A-1B and A-5B) into DUS and along US 6 between I-25 and Kipling Boulevard. Along US 6, ROW is constrained by the frontage road system along US 6, which provides access to homes that are located at the edge of the public ROW.

An example segment of US 6 (6th Avenue), shown in **Exhibit 5-25**, illustrates the extent of potential impacts to the adjacent neighborhoods.

EXHIBIT 5-25: CONSTRAINED ROW ON US 6 - OPTION B (US 6)



North-south alignments are also highly constrained, as development abuts the railroad corridor throughout the metro area. ROW is especially tight in the central section of the alignment into DUS and in the Santa Fe corridor south of Denver. In addition, Denver's urban core is home to older, established residential neighborhoods that may have many properties eligible for or listed on the National Register of Historic Places. There is also high potential for additional historic properties and districts to be identified during future intensive surveys.



Many of the neighborhoods in central Denver, particularly north and west Denver, have higher concentrations of minority or low-income populations that have been previously affected by transportation projects bisecting their communities and may be impacted by HST.

The key environmental and community impacts for the segments through metro Denver are summarized in **Exhibit 5-26**. Of the impacts evaluated these five presented the greater discriminators among the segments being evaluated.

Alignments around Denver (Scenarios B-2A and B-5)

Alignments around Denver also traverse communities and neighborhoods, but transportation corridors are less constrained, with wider buffers between corridors and development, as depicted in **Exhibit 5-27**.

EXHIBIT 5-26: ENVIRONMENTAL AND COMMUNITY IMPACTS OF OPTIONS THROUGH METRO DENVER

	East West Options (A-1A, A-1B, A-5A, and A-5B)		North-South Option (A-1 only)
	A-1A and A-5A: I-76 through Denver	A-1B and A-5B: US 6 through Denver	Railroad/ Santa Fe Corridor
			
Community Disruption*	8.3 linear miles	11.32 linear miles	18.31 linear miles
Parks and Recreation	<ul style="list-style-type: none"> 6 parks potentially affected 4.84 linear miles adjacent to parks 	<ul style="list-style-type: none"> 8 parks potentially affected 5.35 linear miles adjacent to parks 	<ul style="list-style-type: none"> 1 park potentially affected 0.15 linear miles adjacent to parks
Historic Resources	<p>Medium Potential</p> <ul style="list-style-type: none"> No known sites affected Much of corridor is adjacent to industrial and warehousing operations; some older residential homes are present between Pecos and Sheridan 	<p>High Potential</p> <ul style="list-style-type: none"> 3 National Register listed sites potentially affected Neighborhoods and residential homes along US 6 maintain high degree of integrity and are generally post-War or older 	<p>Medium/High Potential</p> <ul style="list-style-type: none"> 2 National Register listed properties potentially affected Potential for historic properties high along established neighborhoods in central Denver
Environmental Justice	<p>Medium Potential</p> <p>Low income/minority populations concentrated in central Denver. Residential development along I-76 further from corridor compared to other alignments.</p>	<p>High Potential</p> <p>Low income/minority populations concentrated along US 6 corridor between Wadsworth and I-25.</p>	<p>High Potential</p> <p>Low income/minority populations concentrated in central Denver, particularly west of I-25 and east of Sheridan.</p>
Stream Crossings	<ul style="list-style-type: none"> 13 stream crossings 1.5 linear miles adjacent to streams 	<ul style="list-style-type: none"> 12 stream crossings 0.55 linear miles adjacent to streams 	<ul style="list-style-type: none"> 23 stream crossings linear miles adjacent to streams

Note: *Community disruption is measured by (miles adjacent to residential/ mixed use development).

EXHIBIT 5-27: OPEN CONSTRUCTION ON E-470

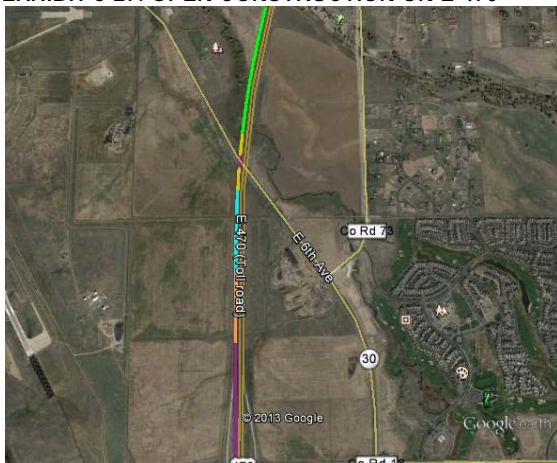

This separation between transportation facilities and development occurred in large part because transportation corridors were developed before residential and mixed-use developments. Land uses were planned around the transportation corridors, including planning for future expansion and even

transit. The exception is the Northwest Quadrant, which is the missing link to the beltway system around Denver. Disagreement about whether or how to develop the Northwest Quadrant has persisted for decades. The beltway segments serving north-south around Denver’s eastern perimeter generally present fewer environmental impacts than the segments along the western perimeter, in part because a high-speed transportation facility has not been developed in the Northwest Quadrant, but also because the Southwest Quadrant alignment follows open space and developed residential areas, such as Chatfield State Park and Highlands Ranch.

Exhibit 5-28 compares the environmental and community impacts of the beltway options that are included in Scenarios A-5A, A-5B, B-2A, and B-5.

EXHIBIT 5-28: ENVIRONMENTAL AND COMMUNITY IMPACTS OF OPTIONS AROUND DENVER

	North-South Options (A-5A, A-5B, B-2A, and B-5)		East-West Option (B-5 only)
	Beltway east around Denver	Beltway west around Denver	Beltway north around Denver
Community Disruption*	5.05 linear miles	9.98 linear miles	7.02 linear miles
Parks and Recreation	None	<ul style="list-style-type: none"> • 12 parks potentially affected • 11.28 linear miles adjacent to parks 	<ul style="list-style-type: none"> • 9 parks/designated open space potentially affected • 6.73 linear miles adjacent to parks
Historic Resources	<p>Low Potential</p> <ul style="list-style-type: none"> • One National Register listed site is potentially affected • Corridor traverses newer developments with low potential for historic importance 	<p>Low Potential</p> <ul style="list-style-type: none"> • No known historic resources affected • Corridor traverses newer developments with low potential for historic importance 	<p>Low Potential</p> <ul style="list-style-type: none"> • No known historic resources affected • Corridor traverses newer developments with low potential for historic importance
Environmental Justice	<p>Low Potential</p> <p>No minority or low-income populations located along alignment</p>	<p>Low Potential</p> <p>No minority or low-income populations located along alignment</p>	<p>Low Potential</p> <p>Corridor generally traverses less developed, newer, and more affluent areas</p>
Stream Crossings	<ul style="list-style-type: none"> • 11 stream crossings • 0.49 linear miles adjacent to streams 	<ul style="list-style-type: none"> • 20 stream crossings • 0.76 linear miles adjacent to streams 	<ul style="list-style-type: none"> • 13 stream crossings • 0.71 linear miles adjacent to streams

Note: *Community disruption is measured by (miles adjacent to residential/mixed-use development)

North of Denver

The N-1 alignment traverses the developed communities of Longmont, Berthoud, Loveland, and Fort Collins, and bisects numerous residential neighborhoods, as shown in **Exhibit 5-29**. Insufficient ROW exists on the freight rail corridor to allow HST to be wholly within the freight ROW, and HST ROW requirements are high.

The N-2 alignment generally follows I-25, and in most locations can be fit within CDOT ROW, as shown in **Exhibit 5-30**. CDOT is open to considering use of the I-25 ROW for HST. The relatively straight alignment allows trains to achieve high speeds, providing good travel times for northern communities making intercity trips. Even outside the highway ROW, community impacts would be minimal because very few residences are located with 1,000 feet of the I-25 corridor. Stream crossings and impacts to farmlands and natural areas occur generally in the same locations that are already impacted by the highway, and new impacts would be minimal.

EXHIBIT 5-29: HST CONSTRUCTION THROUGH LONGMONT (N-1)

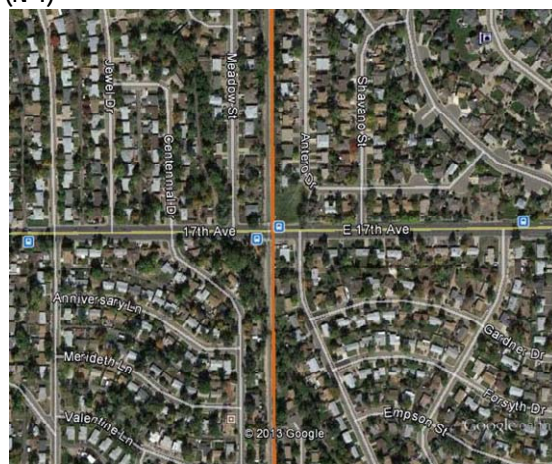

EXHIBIT 5-30: HST ALONG I-25 (N-2)

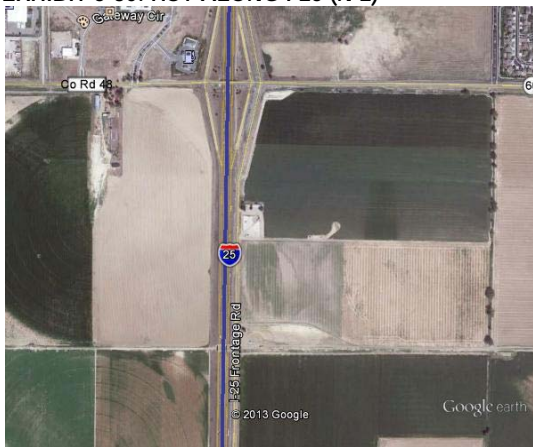

Exhibit 5-31 summarizes the impacts for the alignments north of Denver. The N-2 alignment is preferred and is common to all scenarios.

South of Denver

South of Denver, only one alignment was evaluated in Level 2; therefore, the impacts are identical for all scenarios.

The alignment generally follows I-25 and/or the freight rail corridor from Lone Tree to Castle Rock, Monument, Colorado Springs, Fort Carson, and Pueblo. The S-3 alignment was modified and refined in Level 2 engineering to reduce environmental and community impacts, especially in the Black Forest area of Colorado Springs.

As with the other ICS alignments, environmental and community impacts are greater in developed urban areas where new ROW is needed. Natural resource impacts are greater in the south corridor than the north or Denver area alignments because more open space, habitat, streams, wetlands, and other natural resources are located along this segment compared with other segments of the ICS. However, impacts are the same for all scenarios because all share the same alignment from Denver to Colorado Springs and Pueblo.

Exhibit 5-32 summarizes the impacts of the alignment south of Denver common to all five scenarios.

EXHIBIT 5-31: ENVIRONMENTAL AND COMMUNITY IMPACTS OF N-1 VERSUS N-2

	N-1: Railroad Alignment Segment (I-25 North EIS Commuter Rail)	N-2: I-25 Alignment Segment
Community Disruption*	10.8 linear miles	None
Parks and Recreation	<ul style="list-style-type: none"> 8 potentially affected parks 4.62 linear miles adjacent to parks 	<ul style="list-style-type: none"> 3 potentially affected parks 0.88 linear miles adjacent to parks
Historic Resources	<p>Medium Potential</p> <ul style="list-style-type: none"> Two National Register properties potentially affected Historic property potential in developed areas more than 50 years old 	<p>Low Potential</p> <ul style="list-style-type: none"> No known historic properties affected Potential for historic properties within CDOT right-of-way very low
Environmental Justice	<p>High Potential</p> <p>Low income/minority populations concentrated adjacent to the US 287 corridor within communities of Longmont, Berthoud, Loveland, and Fort Collins</p>	<p>Low Potential</p> <p>Some residential areas north of Timnath, but far from HST alignment</p>
Stream Crossings	<ul style="list-style-type: none"> 12 stream crossings 2.77 linear miles of streams adjacent to HST alignment 	<ul style="list-style-type: none"> 12 stream crossings 0.15 linear miles of streams adjacent to HST alignment

Note: *Community disruption measured by (miles adjacent to residential/ mixed use development).

EXHIBIT 5-32: ENVIRONMENTAL AND COMMUNITY IMPACTS OF THE I-25 SOUTH SEGMENT

S-3: I-25 South Segment	
	
Community Disruption*	2.01 linear miles
Parks and Recreation	<ul style="list-style-type: none"> • 2 potentially affected parks • 1.17 linear miles adjacent to parks
Historic Resources	Medium Potential <ul style="list-style-type: none"> • 3 potentially affected National Register listed properties • Traverses older, established neighborhoods in Pueblo
Environmental Justice	Medium Potential <p>Low income or minority populations concentrated adjacent to much of the corridor through Colorado Springs and along a small (approximately 1.5 linear miles) portion of the alignment through Pueblo</p>
Stream Crossings	<ul style="list-style-type: none"> • 52 stream crossings • 4.96 linear miles of streams adjacent to alignment

Note: *Community disruption measured by (miles adjacent to residential/ mixed use development).

5.5.5 Engineering Feasibility

Engineering feasibility includes the general constructability, capital cost, and operating cost of the finalist scenarios, as discussed below.

General Constructability

Although the degree of challenge varies, all of the proposed scenarios can be constructed. The discriminators are limited to how the HST negotiates the Denver metro area. Scenarios A-1 and A-5 present the greatest challenges because they both penetrate through developed urban areas. Because decisions for moving forward into the Level 3 Evaluation are needed, this evaluation focuses on the choices that have the greatest effect on these key recommendations.

Scenario A-1A (I-76)

Scenario A-1A presents many construction challenges. The difference between this design option and Scenario A-1B is that Scenario A-1A is generally more remote from development, especially east of I-25.

From I-70/C-470 to US 6, the alignment for both Scenario A-1A and A-1B is the same. From US 6 traveling north to SH 58, the Scenario A-1A alignment is located to the south of I-70, largely within the CDOT ROW. However, construction conditions are constrained by a high potential for partial acquisition of private parcels. Most of the construction is at-grade and adjacent to residential areas.

From SH 58 to the I-70/I-76 interchange, a distance of 3.4 miles, the alignment continues on the south side of I-70 in constrained ROW conditions. Approximately 1.25 miles of the alignment are adjacent to residential land uses. The alignment also needs to fly over Ward Road, Kipling Street, and the I-70/I-76 interchange, which would be a major structure approximately 1 mile in length, including the approach ramps. The flyover structure is illustrated in **Exhibit 5-33**.

The alignment continues on the south side of I-76, transitioning from retained fill to grade. It then elevates over 52 Avenue, lowers to grade, and becomes elevated over Clear Creek and Sheridan Boulevard. Near Sheridan Boulevard, construction would pass within 100 feet of a mobile home park. From Tennyson Street to Federal Boulevard, a distance of about 1.2 miles, construction would be challenged by the presence of gravel ponds and other riparian areas. However, this area is fairly remote

from residential areas. From Federal Boulevard to I-25, approximately 2 miles of the alignment is on structure through industrial areas with fairly open construction area. After its elevation over I-25 and then I-270, the alignment is principally at-grade to 96th Avenue. This is industrial land use that includes gravel ponds and an irrigation ditch. Conflicts with residential uses are not apparent. The issues with residences along the north side of 96th Avenue are the same as those discussed for Scenario A-1B.

EXHIBIT 5-33: THREADING THE ALIGNMENT THROUGH THE I-70 AND I-76 INTERCHANGE



North-to-South: The north-south alignment from DUS to DIA has the same challenges as described for Scenario A-1B as the routing is the same. Likewise, the alignment from DUS south to US 6 is the same as described for Scenario A-1B. South of US 6, construction conditions are extremely constrained as the alignment follows the CML/Joint line on a separate ROW to Jewell Avenue, a distance of nearly 4 miles. Further, the majority of the alignment is elevated in this segment, and commercial and industrial properties would need to be acquired to allow construction of the HST. The impacts on private property are lessened once the alignment transitions to the ROW of Santa Fe Boulevard. However, the guideway is elevated for the next 7 miles, generally in the median of Santa Fe Boulevard, as illustrated in **Exhibit 5-34**, complicating construction and affecting worker productivity due to maintenance of traffic and safety issues.

Access to the south side of C-470 would require a long curvilinear aerial structure over the Santa Fe/C-470 interchange, as illustrated in **Exhibit 5-35**. Once on the south side of C-470, the alignment would follow the CDOT ROW and would be the same as required for Scenario B-2A, discussed later in this section.

EXHIBIT 5-34: ALIGNMENT IN MEDIAN OF SOUTH SANTA FE BETWEEN HAMPDEN AND OXFORD

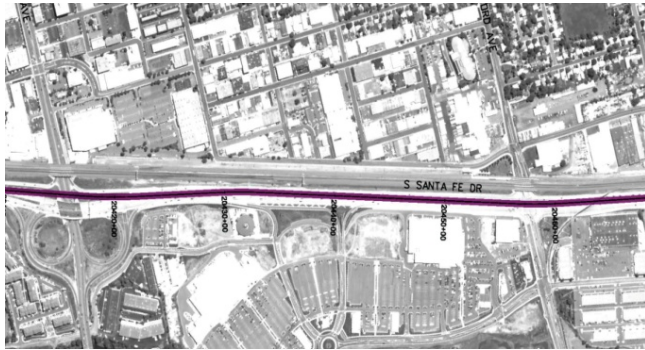

EXHIBIT 5-35: FROM MEDIAN OF SANTA FE, ELEVATED ALIGNMENT OVER NORTHBOUND LANES, COUNTY LINE ROAD, TWO RAILROADS, C-470, AND THE SANTA FE/C-470 FLYOVER RAMP



Scenario A-1B (US 6)

The construction of Scenario A-1B (US 6) is the most challenging. The US 6 alignment would require property acquisition for the majority of its length. The most problematic area would be along US 6 from near Kipling Street to Sheridan Boulevard, where the HST would be elevated for a distance of 4 miles. From Sheridan to I-25, a distance of about 1 mile, the alignment is largely at-grade but would still require extensive private property acquisition. From the I-25 flyover to DUS, constructing 3 miles of elevated structure adjacent to the CML on newly acquired ROW would be highly disruptive to the adjoining industrial and commercial properties. North of DUS to I-270, the construction conditions continue to be challenging as all new ROW is required and conflicts with existing structures, the railroads, and RTD's North Metro and East Rail alignments, which need to be avoided. Near Sand Creek, the alignment becomes elevated over the railroads, the creek, and I-270.

North of this point, the construction would progress through low income and minority neighborhoods from Vasquez Boulevard to East 80th Avenue, a distance of 2.7 miles. Once the alignment approaches 96th Avenue, there is the potential for conflicts with residential units to the north and Rocky Mountain Arsenal to the south. As described above, Scenario A-1A would reduce many of these constructability issues.

Scenarios A-5A and A-5B

Scenarios A-5A and A-5B deploy the same east-west options to DIA –I-76 and US 6, respectively – as described for Scenarios A-1A and A-1B above.

North-to-South: Scenarios A-5A and A-5B follow the E-470 alignment from DIA northwest to the North Suburban Station and from the airport south to the South Suburban Station. It is anticipated that all of the construction would occur within the E-470 ROW. The major constructability challenges would involve elevating the alignment over 20 existing interchanges and/or other structures along E-470.

Scenarios B-2A and B-5

In contrast to Scenarios A-1A, A-1B, A-5A, and A-5B, the construction of Scenarios B-2A and B-5 would largely occur in the C-470 and E-470 ROW in comparatively uncongested areas. However, the beltway construction would involve elevating the HST over numerous interchange ramps along the highway alignment. Scenario B-2A would need to clear 34 structures, and Scenario B-5 would need to clear 22 structures. The aligned is illustrated in **Exhibit 5-36**.

EXHIBIT 5-36: SHIFTING FROM ONE SIDE OF E-470 TO THE OTHER THROUGH CHAMBERS ROAD AND JORDAN ROAD INTERCHANGES SETS UP FLATTER ALIGNMENT TO AVOID SHARP S-CURVES AT PARKER ROAD INTERCHANGE



One key discriminator is that Scenario B-5 would involve construction through the Northwest Quadrant, where many unknowns remain regarding public

acceptance, permitting, and other environmental approvals.

Institutional requirements aside, B-5 appears to represent a slight constructability advantage over B-2A because construction in the Northwest Quadrant is felt to be technically less difficult than what is anticipated along C-470 in the Southwest Quadrant. The C-470 alignment involves 14 structures over interchanges and other roadways, and ROW conditions are expected to be constrained given CDOT's plans for highway expansion. Further, the C-470 alignment is constrained by parkland between the West Suburban Station and Santa Fe Boulevard and limited by urban development from Santa Fe to I-25. The flyover of the C-470/I-25 interchange is expected to be a complicated structure.

North to Fort Collins and South to Pueblo

Construction of the segments north to Fort Collins and South to Pueblo is not a discriminator because these segments are common to all five scenarios.

North to Fort Collins

All scenarios include two segment options for travel north to Fort Collins: N-1: North I-25 EIS Segment and N-2: I-25 Segment. N-1 is not feasible for a HST project due to the very high community impacts of passing through Longmont, Loveland, and Fort Collins, as discussed previously under the Environmental section. Additionally, the cost of N-1, at \$4.2 billion, is much greater than N-2 at \$1.1 billion, and the respective travel times to the North Suburban Station are 41 and 19 minutes. Further, of the two options, N-2 would be much more constructible because essentially all of the work would occur within the I-25 median. Although this would require extensive maintenance of traffic, it would be less complicated than constructing HST through the cities of Longmont, Loveland, and Fort Collins.

Exhibit 5-37 shows the comparison chart for the N-1 and N-2 options presented at a public workshop held in June 2013.

EXHIBIT 5-37: COMPARISON CHART FOR NORTH ROUTE TO FORT COLLINS FROM PUBLIC WORKSHOP NO. 2 ON JUNE 5, 2013

The N1 (EIS) Alignment is Not Compatible with HSIPR	
<u>N1 (EIS)</u>	<u>N2 (I-25)</u>
• Cost = \$2.9 B to \$4.2 B	• Cost = \$1.1 B
• Travel Time to North Suburban Station = 41 minutes	• Travel Time to North Suburban Station = 20 minutes
• Average Travel Speed = 75 mph	• Average Travel Speed = 147 mph
• Much higher community impacts	• Minimal community impacts
• Not compatible with HSIPR	• Compatible with HSIPR

South to Pueblo

Compared to the N-2 (I-25) alignment, construction to the south from the South Suburban Station to Colorado Springs is much more complicated due to severe topography and restricted ROW through Castle Rock and Colorado Springs, as shown on **Exhibit 5-38**. As such, the construction cost per mile (\$52.6 million) is about 44 percent more than for the segment north to Fort Collins, assuming the N-2 (I-25) alignment (\$30.0 million).

EXHIBIT 5-38: RESTRICTED ROW IN RAILROAD ALIGNMENT THROUGH CENTRAL COLORADO SPRINGS

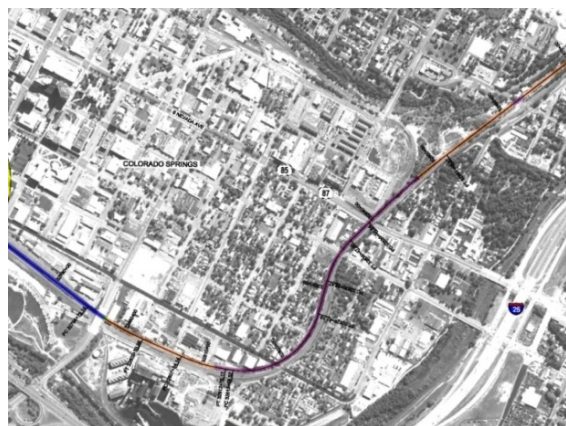

Capital Costs (CAPEX)

This section presents a comparison of the capital costs for the Level 2 Evaluation scenarios. The cost estimates were based on the alignment drawings shown in Appendix B, ICS Engineering Reports and Supporting Information. The values provided are “parametric” estimates – in the first step, the engineering team developed standard cross sections for at-grade track, track on retained fill, track on elevated structure, etc., and in the second step, the team prepared a detailed estimate for each cross section. The costs can then be defined as dollars per lineal foot, dollars per mile, and so forth. In the third step of the process, the engineering team determined the number of miles of each of the standard cross sections required within a given segment. The CAPEX estimates are for the ICS study area only. AGS CAPEX costs will be added to the total when they are available.

Assumptions

The assumptions that served as the baseline for the estimates are given below, by FRA Standard Cost Category (SCC).

SCC 10: Track and Guideway

- Double ballasted track was used at all locations with the exception of elevated structures and tunnels in excess of 500 feet.
- New double track with direct fixation was used for guideway on elevated structures and tunnels in excess of 500 feet. When direct fixation track is utilized, a 100-foot transition length on either side of the structure is identified as direct fixation and the rest of the approach structure is ballasted track.
- New double track on prepared subgrade was used for retained fill sections.
- New double track on new embankment was used for guideway outside of urban areas.
- In the N-2: I-25 corridor, because the alignment traveled within the median of the highway, the proposed track and guideway was designed to minimize the amount of cut-and-fill sections and match the existing terrain for a majority of the alignment. The maximum grade allowed was 3.64 percent for a 0.10 mile segment.
- In the S-3: I-25 South corridor, a combination of elevated structures, retained fill, and 5-foot embankment was utilized. Generally, elevated structures were used in urban areas and retained fill/5-foot embankments were used in non-urban areas. Elevated structures 30 feet in height were used to cross over single-level structures such as at-grade roadways. Elevated structures 60 feet in height were used to cross over multi-level structures such as an elevated highway crossing over I-25. In non-urban areas with relatively level terrain, 5-foot embankments were employed. Retained fill was used in non-urban areas with non-level terrain.
- Below-grade structures for railroad over roadway were used for spans up to 300 feet. Structures longer than 300 feet were considered elevated structures.
- In the Denver Metro area, the ability to get the alignment to an at-grade condition for at least 1,000 feet was considered to be a worthwhile grade change.
- New double track on cut/fill was used for at-grade conditions adjacent to major highways in the Denver Metro area where a bench situation will exist.
- Denver Metro approach structures were assumed to have a 2 percent grade. For an average 30-foot high aerial structure, 800 feet of the approach used retaining walls with 10-foot average wall height, and 700-feet of the approach used retaining walls with 20-foot average wall height.
- For individual segment quantities and costs, the entire segment was included. When these were rolled up to the scenario level, any shared infrastructure (or overlap) was only carried on one segment. An example of this is between E-470 and DIA; while segments B-3 and B-4 and all east segments utilize the same alignment between E-470 and DIA, the infrastructure was only carried on one segment when combined into a scenario.
- Design speeds were held as high as possible within reason through the Denver Metro area. A balance between speed and impact was used in congested areas. All areas of design speeds in excess of 79 mph were assumed to have no vehicular grade crossings.

SCC 20: Stations, Terminals, Intermodal

- Two types of station facilities are assumed: Primary Stations and Secondary Stations. Primary stations are located in areas to accommodate riders from areas where another station is not easily geographically accessible or in highly populated areas to accommodate a large service demand. Primary station sites and associated development require 25 acres of land and accommodate a 2,000-space parking facility. Secondary stations are located between primary stations and in areas with a smaller service demand. Secondary station sites and associated development require 10 acres of land.
- Within the N-2: I-25 corridor, a primary station is located in Fort Collins. In the S-3: I-25 corridor, primary stations are assumed in Pueblo and Colorado Springs. The Denver Metro area has primary stations at DUS and DIA. Note that stations are only carried if the scenario alignments service the area.
- A secondary station for the N-2: I-25 corridor is located in Berthoud. In the S-3: I-25 corridor, secondary stations are located in Castle Rock, Monument, and near Fort Carson. The Denver Metro area has secondary stations at South Suburban (I-25 and E-470 intersection south of Denver) and North Suburban (I-25 and E-470 intersection north of Denver). In some scenarios, an additional secondary station is located at either the Denver National Western Stock Show complex area or I-76/72nd Avenue to facilitate connections between the north-south and east-west alignments.

SCC 30: Support Facilities: Yards, Shops, Administration Buildings

- Four layover facilities are assumed for each scenario, one each in the north, south, east, and central areas. Specific locations were not identified in the Level 2 analyses. Each layover facility requires 5 acres of land.
- One maintenance facility is assumed for each scenario. A specific location was not identified in the Level 2 analyses. The maintenance facility requires 40 acres of land.

SCC 40: Sitework, Right of Way, Land, Existing Improvements

- In rural areas where open drainage can be achieved, a 100-foot ROW was applied to the

entire corridor. In urban areas that are not following a major highway corridor, a 60-foot ROW width was applied to the corridor.

- In areas where the alignment is following a major highway, a 100-foot ROW width was applied in order to help facilitate realignment of any adjacent roads that might be required.
- The exception to the above is in the N-2: I-25 corridor, where the alignment runs in the median of I-25 and no additional ROW is required. Additionally, portions of the S-3: I-25 corridor utilize I-25 ROW and no additional land is needed.

SCC 50: Communications and Signaling

- Automatic Train Control, wayside protection system, and communications with fiber optic backbone will be installed over the entire length of each alignment.

SCC 60: Electric Traction

- Electrification of track will be applied to the entire length of each alignment.

SCC 70: Vehicles

- Vehicle cost was calculated using the total number of trainsets required by the proposed operating plan. An estimate of eight cars per trainset was assumed at a cost of \$70 million for each trainset.

SCC 80: Professional Services

- Project elements included in the Professional Services category are environmental planning, design engineering, program management, construction management and inspection, engineering services during construction, insurance, and testing and commissioning.
- Professional services and other soft costs required to develop the project have been estimated as a percentage of the estimated construction cost as a separate line item:

– Design Engineering	10%
– Insurance and Bonding	2%
– Program Management	4%
– Construction Management and Inspection	6%
– Engineering Services During Construction	2%
– Integrated Testing and Commissioning	2%

- A total Professional Services cost of 26 percent of the total construction cost was applied.

SCC 90: Unallocated Contingency

- Contingencies are an allowance added to the estimate of costs to account for items and conditions that cannot be realistically anticipated.
- Contingency costs were added as an overall percentage of the total construction cost.
- An overall design and construction contingency of 30 percent of the total construction cost was applied.
- Unallocated contingency also includes reserves for utility relocation. Utility relocation costs were calculated as a percentage of the total construction cost for urban and non-urban relocation. Urban relocation is 6 percent of the total construction cost, and non-urban relocation is 3 percent of the total construction cost.
- Environmental mitigation is also considered a contingency cost. Environmental mitigation has been estimated as a percentage of the construction cost:
 - Noise Mitigation 1%
 - Hazardous Waste 1%
 - Erosion Control 0.5%

SCC 100: Finance Charges

The approach to financing has not been determined for Colorado's HST system. For comparison, financial charges during the construction of FTA-funded projects typically range between 5 and 10 percent of the capital cost. For the purposes of this Level 2 Evaluation, 7.5 percent is assumed.

Estimating Results

Exhibit 5-39 presents the capital cost estimates in 2013 dollars. With the exception of Scenario C-1, all of the full-build scenarios are within 12 percent in capital cost. This is because the total mileage of all four of the remaining scenarios is between 208 and 216 miles, or 4 percent. Scenario A-1 with either Option A (I-76) or Option B (US 6) has the highest cost due to the complicated construction through the Denver metro area, both east to west and north to south. The average cost per mile for this scenario is \$71.4 million per mile compared to about \$65 million per mile for the other scenarios.

Scenarios B-2A and B-5 have respective costs of \$13.4 billion and \$13.9 billion, and Scenarios A-1A and A-5A have respective costs of \$15.3 billion and \$14.1 billion. Scenario C-1 is estimated to cost \$11.5 billion. Scenario B-2A costs approximately 17 percent more than the low-cost scenario, C-1, but has ridership that is 28 percent greater. From a capital cost standpoint, B-2A is considered the most cost-effective, and Scenario B-5 ranks second.

5.5.6 Operations and Maintenance Costs

Exhibit 5-40 shows the estimated OPEX by scenario for five different train technologies. As described earlier, the unit costs were taken from the 2010 RMRA Study and updated to 2013 dollars. In general, the Maglev technologies were predicted to have lower O&M cost per train mile than the steel wheel rail technologies.

The train miles were generated based on the service plans developed for each scenario. Scenarios that require the highest number of miles to address their service plans have the highest operating cost (OPEX). Thus, because Scenarios B-2A and B-5 have the highest annual train miles, they also realize the highest OPEX. However, as noted earlier, these Scenarios also produce the highest annual ridership of 13.8 and 13.7 million, respectively.

For the purposes of the Level 2 Evaluation, the average cost per mile for the five technologies, \$50.85, was used for the B/C studies since a technology has not yet been chosen.

5.5.7 Planning Feasibility

Each of the remaining scenarios is feasible from a planning standpoint. All are in conformance with the State Rail Plan, and the concept of HST is consistent with regional planning documents, all of which endorse the concept of increased mode share by transit. The degree to which the scenarios would fulfill local land use plans depends on station location. At the Level 2 Evaluation, station location specifics were not addressed other than general locations for the purpose of travel demand modeling.

The greatest determinant of planning feasibility will be the political will to fund any of the proposed scenarios. The implementation of any scenario will require a major non-federal funding source, such as an increase in sales tax, fuel tax, property tax, etc.

EXHIBIT 5-39: CAPITAL COSTS BY SCENARIO (ICS PROJECT ONLY)

Scenario	A-1A	A-1B	A-5A	A-5B	B-2A	B-5	C-1
							
Total Miles	219.35	208.63	214.67	215.42	208.40	216.00	173.00
Cost Category							
10-TRACK	\$5,519,667,470	\$5,326,576,400	\$5,036,768,660	\$5,141,407,060	\$4,918,755,000	\$5,028,948,790	4,099,736
20-STATIONS	\$425,000,000	\$400,000,000	\$375,000,000	\$400,000,000	\$350,000,000	\$375,000,000	325,000
30-FACILITIES:	\$243,048,000	\$243,048,000	\$243,048,000	\$243,048,000	\$243,048,000	\$243,048,000	243,048
40-SITWORK, RIGHT OF WAY	\$1,151,551,490	\$1,018,332,400	\$965,121,920	\$939,232,550	\$740,776,780	\$876,376,160	736,301
50-COMM/SIGNALS	\$452,085,300	\$429,038,360	\$461,519,000	\$463,131,500	\$448,038,500	\$463,260,500	371,154
60-ELECTRIFICATION	\$1,093,415,620	\$1,037,674,180	\$1,116,232,000	\$1,120,132,000	\$1,083,628,000	\$1,120,444,000	897,676
70-PROFESSIONAL SER	\$2,265,615,810	\$2,155,940,700	\$2,090,410,840	\$2,118,272,530	\$1,083,628,000	\$2,067,304,750	1,701,593
80-UTILITY RELO	\$426,347,660	\$398,169,040	\$373,106,880	\$373,975,450	\$1,984,982,800	\$349,571,980	304,002
90-ENV. MITIGATION	\$222,199,200	\$211,366,740	\$204,942,240	\$207,673,780	\$341,563,050	\$202,676,940	166,822
CONTINGENCY	\$3,539,655,170	\$3,366,043,770	\$3,259,844,860	\$3,302,061,860	\$3,091,619,490	\$3,217,989,330	2,653,600
Total	\$15,338,505,720	\$14,586,189,680	\$14,125,994,410	\$14,308,934,740	\$13,397,017,780	\$13,944,620,440	\$11,498,937
Cost Per Mile	\$69,926,370	\$69,913,240	\$65,803,300	\$66,423,430	\$64,285,110	\$64,705,210	\$66,606,460

EXHIBIT 5-40: OPEX BY SCENARIO (ICS PROJECT ONLY)

Corridor	Concept	Rev. Train-Miles	110 mph Rail	125 mph Maglev	150 mph Rail	220 mph Rail	300 mph Maglev
Cost per Rev. Train-Mile Rates -->			\$54.61	\$49.58	\$53.79	\$54.73	\$41.56
Front Corridor	A1a Basic	3,599,400	\$196,559,000	\$178,462,000	\$193,615,000	\$196,991,000	\$149,608,000
	A1b Basic	3,610,200	\$197,149,000	\$178,997,000	\$194,196,000	\$197,582,000	\$150,057,000
	A5a Basic	3,659,600	\$199,847,000	\$181,447,000	\$196,853,000	\$200,286,000	\$152,110,000
	A5b Basic	3,670,400	\$200,437,000	\$181,982,000	\$197,434,000	\$200,877,000	\$152,559,000
	B2A Basic	4,050,500	\$221,194,000	\$200,828,000	\$217,880,000	\$221,680,000	\$168,358,000
	C1 Basic	3,719,780	\$203,133,000	\$184,431,000	\$200,091,000	\$203,580,000	\$154,612,000
	B5 Basic	4,067,800	\$222,138,000	\$201,686,000	\$218,811,000	\$222,626,000	\$169,077,000
Mountain	A1a Basic	1,486,900	\$81,198,000	\$73,722,000	\$79,982,000	\$81,376,000	\$61,803,000
	A1b Basic	1,485,500	\$81,122,000	\$73,653,000	\$79,906,000	\$81,300,000	\$61,744,000
	A5a Basic	1,486,900	\$81,198,000	\$73,722,000	\$79,982,000	\$81,376,000	\$61,803,000
	A5b Basic	1,485,500	\$81,122,000	\$73,653,000	\$79,906,000	\$81,300,000	\$61,744,000
	B2A Basic	1,490,300	\$81,384,000	\$73,891,000	\$80,165,000	\$81,563,000	\$61,944,000
	C1 Basic	1,488,500	\$81,285,000	\$73,801,000	\$80,068,000	\$81,464,000	\$61,869,000
	B5 Basic	1,490,000	\$81,367,000	\$73,876,000	\$80,149,000	\$81,546,000	\$61,931,000
TOTAL	A1a Basic	5,086,300	\$277,757,000	\$252,184,000	\$273,597,000	\$278,367,000	\$211,411,000
	A1b Basic	5,095,700	\$278,271,000	\$252,650,000	\$274,102,000	\$278,882,000	\$211,801,000
	A5a Basic	5,146,500	\$281,045,000	\$255,169,000	\$276,835,000	\$281,662,000	\$213,913,000
	A5b Basic	5,155,900	\$281,559,000	\$255,635,000	\$277,340,000	\$282,177,000	\$214,303,000
	B2A Basic	5,540,800	\$302,578,000	\$274,719,000	\$298,045,000	\$303,243,000	\$230,302,000
	C1 Basic	5,208,280	\$284,418,000	\$258,232,000	\$280,159,000	\$285,044,000	\$216,481,000
	B5 Basic	5,557,800	\$303,505,000	\$275,562,000	\$298,960,000	\$304,172,000	\$231,008,000

Funding from sources other than the federal government will likely need to approach 50 percent of the total capital cost of the scenario to attract private and/or federal funding. Absent the political will to increase revenues, a HST for Colorado will not be feasible. This conclusion holds true for all of the scenarios and is not a discriminator for selection.

5.5.8 Benefit/Cost Analysis

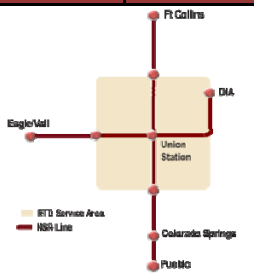
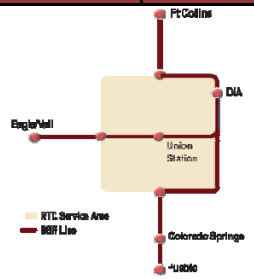
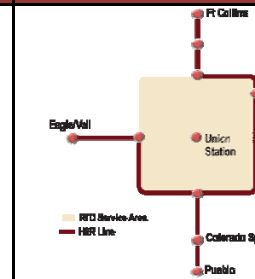
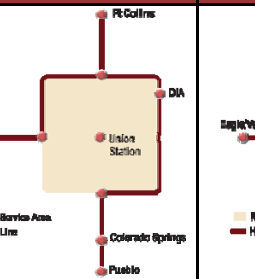
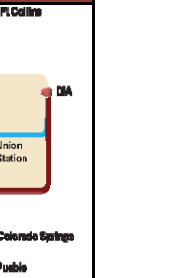
BCA is a widely used analytical technique that provides a common denominator for comparing costs and benefits of public investments in order to assist policymakers in making decisions about public expenditures. This analysis considers the benefits and costs of alternative alignments as well as whether the benefits of HST outweigh the costs. It is a technique that considers the long-term benefits and shorter-term costs, which is important given the multi-year timeframe of the project. The BCA also incorporates the time value of money in order to capture future values and benefits.

Assumptions

The B/C studies evaluate the feasibility of the ICS portion of the statewide HST program only. The AGS portion of the system will be added once CAPEX estimates have been developed.

Dollar figures in this analysis are expressed in constant 2013 dollars. In order to adjust the future value of cash flows, a discount rate was used. The discount rate used for the evaluation of public projects differs from the interest rate employed in private investments and is an often-debated topic. For comparison purposes, the 10-year U.S. Treasury bond rate is currently under 2 percent. A discount rate of 4 percent was used in the analysis over a period of 30 years. The higher the discount rate, the lower the present-value estimate.

Costs

- *Capital Expenditures (CAPEX) and Annual Operating Expenditures (OPEX) were based on the estimates presented earlier in this section.*

- *Interest payments* were assumed at 4 percent interest and a 30-year repayment period, using a simple amortization schedule, for 50 percent of the capital costs. The analysis assumes that half of the upfront capital costs for this project will be bonded with repayment to a governmental entity. It should be noted that repayment does not typically follow a simple principal and interest schedule for these types of large capital projects; however, at this level of analysis, it was deemed an appropriate method for calculating interest. The repayment schedule is often based on the timing of grants and other factors.

Benefits

Basic Data

- **Ridership** - Calculated based on the travel demand model.
- **Ticket Revenue** - Based on an assumption of revenues of \$.35 per mile and ridership.
- **Reduction in Vehicle Miles Traveled (VMT)** - VMT and the associated benefits calculations are based on the results of the travel demand model and are driven by the impacts of people switching from other modes to HST.
- **Reduction in Vehicle Hours Traveled (VHT)** - Relates to the amount of time individuals spend traveling to their destinations. In order for benefits to be counted, vehicle-hours have been translated into dollar figures. While time can be valued at different rates depending on the activity (leisure, work, etc.), an average wage rate of \$23 per hour was used for purposes of this analysis. The average wage rates for Colorado and the United States were similar at approximately \$23 per hour (U.S. Bureau of Labor Statistics, 2012).
- **Fatalities Avoided** - Results from a reduction in VMT and the corresponding reduction in automobile accidents and associated fatalities. The number of fatalities is based on 1.1 fatalities per 100 million miles driven (National Highway Traffic Safety Administration 2011 estimates). Fatalities are valued at \$6.2 million per life saved (Trottenberg, 2011).
- **Pollution Benefits** – With decreased VMT, there would be fewer harmful particulates and greenhouse gas emissions. Both businesses and the general public would benefit from a better environment and better overall public health. The benefits are estimated at \$0.199 per reduction in VMT based on research into public health and environmental benefits by the Victoria Transportation Policy Institute (Victoria Transportation Policy Institute, 2012).

Calculated Benefits (Present Worth Basis)

The Present Worth (PW) for the majority of benefits was calculated based on a 4 percent discount rate over a 30-year period, as explained above. Any exceptions are noted in the narrative.

- **Increase in Real Estate Value** – Calculated for the ICS stations only. At this level, very general assumptions were made about the development readiness of the sites and future densities since specific locations have not been discussed. It was assumed that there would be 15 to 25 acres of land immediately around the future station areas directly influenced by the presence of the station. These land areas were adjusted assuming that significant infrastructure would be needed at most of the locations. Floor to Area Ratios (FARs) were used to estimate density assuming FARs of 3 to 5; a FAR of 1 would be seen at newer pedestrian-oriented suburban mixed-use neighborhoods such as Belmar in Lakewood. Valuations of \$180 per square foot were used based on commercial real estate sales in different parts of the Front Range tracked by the *Colorado Real Estate Journal* in early 2013.
- **Operations Jobs** – The value of labor or jobs was assumed to be half of the overall OPEX estimate. It was also valued at a 4 percent discount rate over a 30-year period.
- **Non-Basic Jobs** – Operations jobs were assumed to have a 1.5 multiplier effect throughout the economy, creating indirect and induced benefits. These impacts include the jobs, incomes, and output of people involved in operating the system, and the additional jobs and earnings created by the operations. It also includes an estimate of the induced impacts related to the spending of operations workers. For every operations job, a total of 1.5 jobs would be created (including the original operations jobs) based on Bureau of Economic Analysis (BEA) Regional Input-Output Modeling System (RIMS II) multipliers.
- **50 Percent Federal Funding and Multiplier Effect** – It was assumed that 50 percent of the capital expenditures would come from the federal

government. Because the source of the funds is from outside of the state economy, this funding would have a potentially higher multiplier than spending from local sources. Recent research conducted by economists at the Federal Reserve Bank in San Francisco estimate an overall multiplier of 3 for these types of projects (Leduc and Wilson, 2012).

- **50 Percent Construction Jobs and Multiplier Effect** – It was assumed that half of the CAPEX would be for labor and that construction would take place over a 10-year time period. The present-worth calculation was adjusted accordingly. For every construction job, a total of two jobs would be created (BEA RIMS II multipliers).

Benefit/Cost Results

The results from the B/C studies are not a strong discriminator at the Level 2 Evaluation, as shown on **Exhibit 5-41**, as all scenarios experience ratios of around 2.0. This is because the largest contributing benefits – employment and the multiplier effects of large federal grants – are comparable among the scenarios. It is important to emphasize that with the exception of how the scenarios penetrate the Denver metro area, the physical configurations are the same for each.

Operating Ratio Results

A positive operating ratio is important because the surpluses can be used to help pay for the annualized capital payment for the system. Compared to the B/C, there is more variability with the operating ratios realized by the Level 2 scenarios, which range from a high of 1.45 for Scenarios A-1B and A-5B (US 6) to 1.05 for Scenario C-1. Scenarios A-1A, A-5A, A-5B, B-2A, and B-5 have operating ratios of 1.32, 1.32, 1.35, 1.21, and 1.19, respectively. Scenarios B-2A and B-5 have lower ratios because their beltway alignments generate additional annual train miles, and hence a higher OPEX. At the Level 2 Evaluation, the OPEX ratios are based on an average of the unit prices assumed for each technology.

5.5.9 Financial Considerations

At the Level 2 Evaluation, the financial consequence of implementing one of the ICS scenarios was presented to the PLT and at the public workshops. It was communicated that even considering federal funding that the local obligation will likely amount to several

hundred million dollars per year. Further, it was stated that a major new source of state funding will be required. Funding options such as increases in fuel taxes, vehicle registration taxes, VMT taxes, sales taxes, income taxes, development fees and so forth were presented to the PLT and at the public workshops. None of these sources of funding received a high level of support. Fees such as HST ticket revenue, lodging taxes, lottery taxes and ‘sin’ taxes were more supported. However, these taxes will not generate the needed level of revenue to fund a HST system in Colorado. More information on the refinements to project financing is provided in Section 8, Implementation Plan.

5.6 Recommendations for Level 3 Evaluation

This section provides recommendations for the Level 3 Evaluation.

5.6.1 Scenarios Retained

Based on the Level 2 Evaluation, three of the scenarios are recommended for further refinement in the Level 3 Evaluation:

- Scenario A-5A (I-76)
- Scenario B-2A
- Scenario C-1

Scenario A-5A was retained because it best serves DIA with one-seat ride from all markets and provides better connections to the central Denver area than Scenario B-2A. While it requires a transfer from RTD’s North Metro CRT to DUS, it could also provide a strong connection to the Gold Line Commuter Rail and eventual Northwest Commuter Rail project at the Pecos Station for an alternate trip to DUS. Scenario A-5A is recommended because it results in fewer community impacts than Scenario A-5B. It was also determined that one “through Denver” scenario needed to be carried into the Level 3 Evaluation, and Scenario A-5A costs less and has fewer impacts than Scenario A-1A while producing comparable ridership.

Scenario B-2A was recommended for Level 3 Evaluation because it produces the best ridership at the lowest cost of all scenarios with the exception of C-1. It would also avoid the impacts of construction through the Denver metro area. It provides the best access for populations from the southern markets and would have strong access from the northern markets.

EXHIBIT 5-41: SUMMARY B/C RESULTS BY SCENARIO (ICS ONLY)

B/C Element	Scenario A-1a	Scenario A-1b	Scenario A-5a	Scenario A-5b	Scenario B-2a	Scenario B5	Scenario C-1
	Basic	Basic	Basic	Basic	Basic	Basic	Basic
Costs							
CAPEX	15,338,506,000	\$ 14,586,189,000	14,125,994,000	14,308,935,000	13,397,000,000	13,945,000,000	11,499,000,000
Annual OPEX	\$ 183,047,000	\$ 183,596,200	\$ 186,108,600	\$ 186,657,800	\$ 205,988,000	\$ 206,867,600	\$ 189,200,000
OPEX Cost (30 year)	\$ 3,164,882,630	\$ 3,174,378,298	\$ 3,217,817,694	\$ 3,227,313,362	\$ 3,561,532,520	\$ 3,576,740,804	\$ 3,271,268,000
Interest payments	\$ 5,511,815,439	\$ 5,241,474,086	\$ 5,076,105,314	\$ 5,141,844,248	\$ 4,814,144,965	\$ 5,011,066,025	\$ 4,132,108,155
Total Cost	\$ 24,015,204,069	\$ 23,002,041,384	\$ 22,419,917,008	\$ 22,678,092,610	\$ 21,772,677,485	\$ 22,532,806,829	\$ 18,902,376,155
Benefits							
Basic Data							
Ridership	9,981,048	10,817,411	10,486,660	10,760,464	10,853,263	10,922,590	8,811,343
Ticket Revenue	\$ 241,102,808	\$ 265,529,561	\$ 246,469,103	\$ 251,271,850	\$ 249,983,676	\$ 247,117,358	\$ 197,850,186
Reduction in Vehicle-Miles ¹	296,118,104	325,409,895	284,075,042	287,788,682	292,981,842	284,668,554	220,233,121
Reduction in Vehicle-Hours ¹	713,675	1,013,611	767,627	812,549	979,328	929,069	357,502
VMT Benefit	\$ 165,826,138	\$ 182,229,541	\$ 159,082,023	\$ 161,161,662	\$ 164,069,831	\$ 159,414,390	\$ 123,330,548
VHT Benefit	\$ 16,414,519	\$ 23,313,060	\$ 17,655,427	\$ 18,688,636	\$ 22,524,544	\$ 21,368,581	\$ 8,222,543
Fatality Avoided	\$ 20,195,255	\$ 22,192,955	\$ 19,373,918	\$ 19,627,188	\$ 19,981,362	\$ 19,414,395	\$ 15,019,899
Calculated Benefits (PW basis)							
Increase in Real Estate Value - one time deal, no PW calc.	\$ 3,100,000,000	\$ 3,100,000,000	\$ 3,100,000,000	\$ 3,100,000,000	\$ 3,100,000,000	\$ 3,100,000,001	\$ 3,100,000,000
Fare Box Revenue (30 year)	\$ 4,168,667,548	\$ 4,591,006,112	\$ 4,261,450,797	\$ 4,344,490,279	\$ 4,322,217,762	\$ 4,272,659,117	\$ 3,420,829,717
PW of VMT	\$ 2,867,133,930	\$ 3,150,748,764	\$ 2,750,528,185	\$ 2,786,485,134	\$ 2,836,767,384	\$ 2,756,274,811	\$ 2,132,385,176
PW of VHT	\$ 283,807,033	\$ 403,082,807	\$ 305,262,332	\$ 323,126,524	\$ 389,449,369	\$ 369,462,769	\$ 142,167,775
PW of Fatality Avoided	\$ 349,175,954	\$ 383,716,189	\$ 334,975,040	\$ 339,354,082	\$ 345,477,742	\$ 335,674,897	\$ 259,694,052
Pollution benefits	\$ 1,018,856,522	\$ 1,119,641,078	\$ 977,419,837	\$ 990,197,396	\$ 1,008,065,553	\$ 979,461,942	\$ 757,758,303
PW of Operations Jobs	\$ 1,582,441,315	\$ 1,587,189,149	\$ 1,608,908,847	\$ 1,613,656,681	\$ 1,780,766,260	\$ 1,788,370,402	\$ 1,635,634,000
PW of Non-basic jobs (1.5 multiplier)	\$ 791,220,658	\$ 793,594,575	\$ 804,454,424	\$ 806,828,341	\$ 890,383,130	\$ 894,185,201	\$ 817,817,000
50% Federal funding	\$ 7,669,253,000	\$ 7,293,094,500	\$ 7,062,997,000	\$ 7,154,467,500	\$ 6,698,500,000	\$ 6,972,500,000	\$ 5,749,500,000
Multiplier effect of Federal funding (3.0 multiplier)	\$ 15,338,506,000	\$ 14,586,189,000	\$ 14,125,994,000	\$ 14,308,935,000	\$ 13,397,000,000	\$ 13,945,000,000	\$ 11,499,000,000
Construction Employment	\$ 6,219,764,183	\$ 5,914,699,640	\$ 5,728,090,567	\$ 5,802,273,143	\$ 5,432,483,500	\$ 5,654,697,500	\$ 4,662,844,500
Non-basic jobs (2.0 multiplier)	\$ 4,105,044,361	\$ 3,903,701,762	\$ 3,780,539,774	\$ 3,829,500,274	\$ 3,585,439,110	\$ 3,732,100,350	\$ 3,077,477,370
Total Benefits	47,493,870,503	\$ 46,826,663,575	\$ 44,840,620,801	\$ 45,399,314,353	\$ 43,786,549,811	\$ 44,800,386,990	\$ 37,255,107,893
Sum of Benefits (PW Cost Basis)	\$ 47,493,870,503	\$ 46,826,663,575	\$ 44,840,620,801	\$ 45,399,314,353	\$ 43,786,549,811	\$ 44,800,386,990	\$ 37,255,107,893
Sum of Costs (PW Cost Basis)	\$ 24,015,204,069	\$ 23,002,041,384	\$ 22,419,917,008	\$ 22,678,092,610	\$ 21,772,677,485	\$ 22,532,806,829	\$ 18,902,376,155
B/C Ratio	1.98	2.04	2.00	2.00	2.01	1.99	1.97
Operating Ratio	1.32	1.45	1.32	1.35	1.21	1.19	1.05

This is partially offset by the fact that travel from the mountains, while still a one-seat ride, is longer than for Scenarios A-1 or A-5.

Scenario C-1 was retained because it accommodates phasing of a HST program for the state.

5.6.2 Scenarios Set Aside

Based on the Level 2 Evaluation, the following scenarios have been set aside:

- Scenario A-1A and A-1B
- Scenario A-5B
- Scenario A-6
- Scenario B-5

Scenarios A-1A and A-1B were set aside due to the anticipated high level of community impacts from constructing a HST system north-south and east-west through the Denver metro area. This system is also more likely to be construed as competition and redundancy to RTD's FasTracks program. Using the less impactful Option A (I-76), the ridership is the lowest of the full-build scenarios. With Option B (US 6), the ridership is competitive but the impacts are too damaging.

Scenario A-5B was set aside because of the high level of community impacts associated with constructing HST along US 6 (Option B) and into DUS. The PLT advised the project team that attempts to construct this alignment would not be approved through NEPA. Scenario A-5A was considered much easier to implement since the I-76 alignment (Option A) would have fewer community impacts than the US 6 alignment.

Scenario A-6 was set aside early in the Level 2 Evaluation because the \$20-billion cost was not considered implementable. Further, the community impacts of this scenario are similar to those of Scenarios A-1A and A-1B, with the addition of the impacts associated with the beltway segments.

Scenario B-5 was set aside because of a lack of support from the City of Golden and because it provided poor connections for travelers from the southern markets.

5.6.3 Segments Set Aside

Based on the Level 2 Evaluation, the following segments have been set aside:

- Segment S-1 (Greenfield)
- Segment N-1 (EIS)

Segment S-1 (Greenfield) south to Colorado Springs and Pueblo was set aside between the end of Level 1 Evaluation and the initiation of Level 2 Evaluation due to intensive public opposition for constructing HST through the Black Forest community north of Colorado Springs. It was replaced with Segment S-3, shown in **Exhibit 5-42**, which closely follows the I-25 alignment.

EXHIBIT 5-42: SEGMENT S-3: I-25



Segment N-1 (EIS), was set aside because it is not suitable for HST from cost, travel time, or environmental standpoints. Constructing HST with competitive travel times through the cities of Longmont, Berthoud, Loveland, and Fort Collins would have required extensive elevated structure and private property acquisition, increasing community impacts to unacceptable levels and escalating the cost to over three times that of Segment N-2 (I-25), shown in **Exhibit 5-43**.

EXHIBIT 5-43: SEGMENT N-2: I-25



The operation of HST was also considered unacceptable. Further, the North I-25 EIS ROD has committed the SH 287 corridor to commuter rail, which is supported publicly. HST on the SH 287 segment is not supported by the public.

Exhibit 5-44 provides a summary of the HST scenarios that are recommended for Level 3 Evaluation.

EXHIBIT 5-44: SUMMARY OF HST SCENARIOS RECOMMENDED FOR LEVEL 3 EVALUATION

Scenarios Recommended for Level 3 Evaluation		
<p>A-1A and A-1B: Direct Alignments through Denver</p> <ul style="list-style-type: none"> • CAPEX - \$14.6 - \$15.3 billion • OPEX - \$183 million/year • Ridership - 12.1 to 13.1 million/year • Revenue - \$250 million/year • OPEX Ratio - 1.32/Option A to 1.45/Option B • B/C Ratio - 1.98/Option A to 2.04/Option B <p>SET ASIDE:</p> <ul style="list-style-type: none"> ▪ Performs well but results in high community impacts to the Denver metro area. ▪ Scenarios A-5A, A-5B, B-2A, and B-5 perform as well or better and generally cost less. ▪ Obtaining environmental clearances through the Denver metro area would take a long time and be potentially contentious, eroding public support for the HST program. ▪ It does not serve DIA from north or south well due to a lengthy transfer at DUS and competition from RTD's lower fares and good travel times. 	<p>A-5A and A-5B: Eastern Beltway</p> <ul style="list-style-type: none"> • CAPEX - \$14.1 - \$14.3 billion • OPEX - \$186 million/year • Ridership - 12.9 (Option A) to 13.1 million/year (Option B) • Revenue - \$257 million/year • OPEX Ratio - 1.32/Option A to 1.35/Option B • B/C Ratio - 2.0/with either Option A or Option B <p>CARRY FORWARD: A-5A</p> <p>SET ASIDE: A-5B</p> <ul style="list-style-type: none"> ▪ Scenario A-5A performs nearly as well as Scenarios A-1A, A-1B and A-5B but with fewer community impacts. Construction and operation of HST on the US 6 alignment is considered by both the project team and the PLT to be un-implementable. ▪ The impacts of A-5A are greater than for Scenarios B-2A, B-5, or C-1 because construction and operation of HST on the I-76 alignment is believed to result in more impact than construction and operation of HST on the beltways around developed areas. ▪ A-5A serves DIA with one-seat ride from all the mountain markets but requires more out-of-direction travel to and from the mountains from the north and south markets due to the need for a transfer at DIA. 	<p>A-6: Complete Beltway</p> <ul style="list-style-type: none"> • CAPEX: \$20.3 billion • OPEX: \$588 million/year • Ridership - Not evaluated • Revenue - Not evaluated • OPEX Ratio - Not evaluated • B/C Ratio - Not evaluated <p>SET ASIDE:</p> <ul style="list-style-type: none"> ▪ While this scenario would provide the most thorough transit coverage of the scenarios considered, it comes with extremely high capital and operating costs. ▪ Community and environmental impact of construction through and around the Denver metro area are the highest of all of the scenarios considered and would likely prevent the implementation of this scenario.

EXHIBIT 5-44: SUMMARY OF HST SCENARIOS RECOMMENDED FOR LEVEL 3 EVALUATION

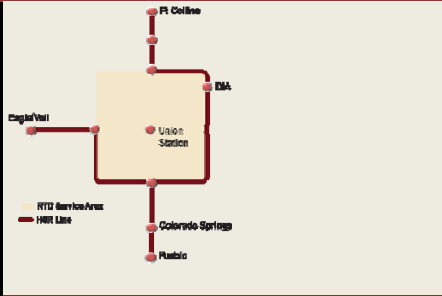
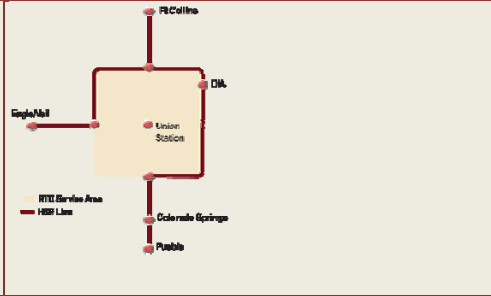
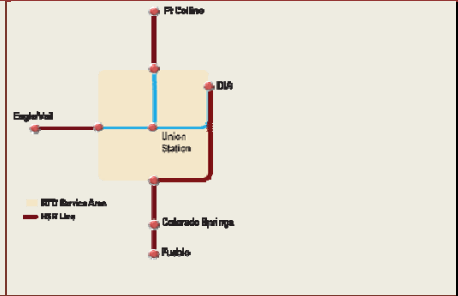
		
<p>B-2A: Denver Periphery Excluding the Northwest Quadrant</p> <ul style="list-style-type: none"> • CAPEX - \$13.4 billion • OPEX - ~\$205.0 million/year • Ridership – 13.8 million/year • Revenue - \$249.0 million/year • OPEX Ratio – 1.21 • B/C Ratio – 2.01 <p>CARRY FORWARD:</p> <ul style="list-style-type: none"> ▪ Generates the highest ridership, and the highest revenue; however, the operating ratio is lower than Scenario A-1 or A-5. ▪ Lowest capital cost of any of the full-build scenarios. ▪ Avoids the community and environmental impacts of construction and operation through the Denver metro area. ▪ The one key disadvantage of this scenario is that it does not provide service to DUS. 	<p>B-5: Denver Periphery Excluding the Southwest Quadrant</p> <ul style="list-style-type: none"> • CAPEX - ~\$13.9 billion • OPEX – \$207.0 million/year • Ridership – 13.7 million/year • Revenue - ~\$248.0 million/year • OPEX Ratio – 1.19 • B/C Ratio – 1.99 <p>SET ASIDE:</p> <ul style="list-style-type: none"> ▪ While this scenario has many of the benefits of B-2A, <u>it is not supported by many of the Northwest Quadrant stakeholders</u> and is considered to be much more difficult to implement than Scenario B-2A. ▪ The benefits of B-5 include: <ul style="list-style-type: none"> ▪ Generates the second highest ridership and the second highest revenue; like B-2A the operating ratio of B-5 is lower than either A-1 or A-5. ▪ Second lowest capital cost of any of the full-build scenarios. ▪ Like B-2A, avoids the community and environmental impacts of construction and operation through the Denver metro area. ▪ Like B-2A, the key disadvantage of this scenario is that it does not provide service to DUS. 	<p>C-1: Shared Track with RTD</p> <ul style="list-style-type: none"> • CAPEX: - \$11.5 billion • OPEX - \$189.2 million/year • Ridership - 10.8 million/year • Revenue - \$205 million/year • OPEX Ratio – 1.05 • B/C Ratio – 1.97 <p>CARRY FORWARD:</p> <ul style="list-style-type: none"> ▪ Represents a possible phasing strategy to the other full-build scenarios. ▪ While it has the lowest capital cost, it also has the weakest ridership and the lowest OPEX ratio. ▪ Maintains a B/C ratio comparable to the other scenarios. ▪ Provides very strong access to DIA from southeast Denver, Colorado Springs and Pueblo due to the one-seat ride available to these locations. Because it requires a transfer to communities north and west, its ridership is weaker.

This page intentionally left blank.

Section 6: Level 3 Evaluation

The section presents the process used to both select and improve the cost-effectiveness of the Locally Preferred Alternative (LPA) for the ICS (ICS LPA). A separate study has recommended an LPA for the AGS program. While this section focuses on the ICS LPA, many of the travel demand modeling studies combined both projects as a full statewide system. The combination of the ICS and AGS projects is referred to as the High Speed Transit (HST) Vision.

During Level 3, the ICS LPA was refined by undertaking additional engineering using digital terrain mapping and further analysis of environmental issues. The refined ICS LPA was then re-modeled to determine the impact of refinements on ridership and operations. Additional environmental analyses were conducted to determine “show stoppers” to avoid and impacts to mitigate.

The following subsections support the Level 3 Evaluation findings:

- Level 3 Evaluation Commitments
- What We Have Learned
- Selection and Configuration of the ICS LPA
- Value Engineering Inputs to the ICS LPA
- Consequences of Implementing the ICS LPA

6.1 Level 3 Evaluation Commitments

At the completion of each phase of analysis, the ICS team has made commitments for the succeeding phase based on inputs from the PLT and the public. The Level 3 Evaluation commitments made at the conclusion of Level 2 Evaluation are given below.

6.1.1 Planning Studies

- Define the system performance, engineering, political and environmental advantages and disadvantages of the remaining alternative scenarios so that discriminators are readily apparent to the PLT and stakeholder groups

- Optimize the alignment for the north-south corridor outside of the Denver metro area (north of E-470 and south of C-470)
- In conjunction with the AGS Team, optimize the alignment for the I-70 mountain corridor outside of the Denver metro area (west of C-470)
- Identify the best alignment through the Denver metro area to DIA
- Identify the projected ridership, revenues, and operating surplus for the ICS LPA
- Define a phasing strategy for the ICS LPA
- Define a funding and financial strategy for the ICS LPA
- Define a regulatory strategy for the ICS LPA
- Define a cost-effective Minimum Operating Segment (MOS) for Phase I implementation

6.1.2 Engineering Studies

- Recommend a preferred technology
- Value engineer the remaining scenarios to improve cost-effectiveness
- Analyze the potential for single-track configuration
- Further refine the alignments based on additional terrain data
- Better define ROW requirements
- Revise the CAPEX estimates to account for engineering refinements
- Prepare a phasing strategy

6.1.3 Public Involvement

- Hold public meetings in Fort Collins, Denver, Colorado Springs, and Pueblo at the conclusion of the Level 3 Evaluation
- Hold PLT meetings in August, September, and October 2013
- Update the project website as needed

6.2 What We Have Learned

Through the completion of the Level 1, 2, and 3 Evaluations, the study team developed the conclusions presented in subsections 6.2.1 through 6.2.5.

6.2.1 Public Benefits

- All of the Level 3 scenarios investigated met the project Purpose and Need.
- The cost/benefit ratio of implementing HST is positive – that is, the economic, environmental, and community benefits are greater than the cost to implement the system.
- Station development is expected to result in dramatic increases in local assessed valuation.
- Ridership demand and operating plans indicate that fares (ticket sales) would generate excess revenue that could offset some capital costs of expanding the system.
- If federal funding were obtained to match local investments, HST would generate substantial economic benefits for Colorado as a whole in the form of construction and spin-off jobs.

6.2.2 Transportation Benefits

- Ridership of 18 million per year is expected with the HST Vision program.
- Alignments around the Denver metro area have as much or more projected ridership than alignments through the urban area.
- About 72 percent of projected ridership is Front Range related, but the AGS segments are important for revenue.
- About 80 percent of the ridership is expected to be intercity.
- Diversion of aviation trips to transit trips is expected to be comparatively minor.
- A “one seat ride” from Eagle County Regional Airport to DIA is possible only with Maglev technology.
- Cross-platform transfers are expected to reduce ridership by about 5 percent system-wide.

6.2.3 Environmental Considerations

- All scenarios and MOS options considered would have positive effects on vehicle miles traveled (VMT) and vehicle hours traveled (VHT).
- All scenarios would have a positive effect future land use.
- At this point, the study team identified no environmental “show stoppers.”
- The ICS LPA will have direct impacts on 1,200 to 1,500 acres.
- Alignments around the Denver metro area dramatically reduce community impacts.
- All of the alignments through and around the Denver metro area have environmental constraints, but construction on the I-76 segment is expected to have more impacts than construction on the C-470 and Northwest Quadrant segments.
- Truncating the HST alignment at Briargate reduces impacts in Colorado Springs (COS).
- Future construction through COS will be challenging.
- Federal funding and other areas of federal involvement (i.e., permitting, approvals, etc.) require compliance with NEPA and other federal environmental laws and regulations. Completing environmental studies will be complicated and time consuming due to the geographic scope of the ICS LPA.

6.2.4 Engineering

- While high-speed rail (HSR) technology will most likely be used for the Front Range segments, both HSR and Maglev technologies are carried into the final report.
- High-speed Maglev technology appears to be the most likely technology for the I-70 mountain corridor segments.
- The HST Vision program is anticipated to cost about \$70 million to \$80 million per mile for HSR (steel wheel) technology and \$90 million to \$100 million per mile for Maglev technology in 2013 dollars).
- The use of double track only at stations (hence single track for the remainder of the alignment)

- would save up to 30 percent of CAPEX but significantly reduce ridership.
- There is opportunity to “single track” portions of the system, resulting in anticipated cost savings of over \$1 billion with no impact on ridership.
- The ICS LPA will require 1,200 to 1,500 acres of ROW.
- The beltway segments are more constructible than the I-76 segment.
- The I-25 median to Fort Collins is no longer available for HST due to future widening of I-25, significantly increasing costs for that portion of the project.
- Because of the potential advantages of Maglev technology in the future, both that technology and HSR will be carried to the final report.

6.2.5 Financial

- Federal funding is a must to implement the HST Vision in Colorado.
- Low-interest loans from Railroad Rehabilitation and Improvement Financing (RRIF) and Transportation Infrastructure Finance and Innovation Act (TIFIA) could be used to keep interest rates below 4 percent.
- Private-sector financing would carry interest charges of 10 to 12 percent and would be limited to approximately 25 percent of the total project capital cost.
- Any scenario or MOS would require a major new source of funding at the state level; generally, a sales tax of at least \$0.005 (½ cent) per dollar is needed.
- All 16 counties that would benefit from the HST need to participate in funding as the leverage of the populated Front Range is needed.
- A “pay to play” strategy is impossible for a mountain system, increasing the sales taxes needed to nearly \$0.30 per dollar.
- A sales tax dedicated to a state transportation program appears to be the best mechanism for fulfilling the State match to fund the HST Vision.
- Local government contributions would optimistically be limited to covering station costs.



- The economics of the system are not sufficient to attract a public-private partnership (P3) concessionaire without significant federal and state investment.

6.3 Selection and Configuration of the ICS LPA

This section details the process for selecting and configuring the ICS LPA. A technical description of the ICS LPA is also provided.

At the end of the Level 2 Evaluation, three scenarios had PLT endorsement, as shown in **Exhibit 6-1**:

EXHIBIT 6-1: REMAINING SCENARIOS

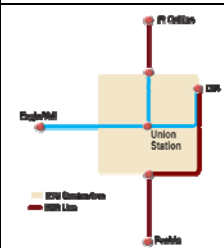
Scenario	Concept
A-5A (I-76): Eastern Beltway	
B-2A : Denver Periphery Excluding the Northwest Quadrant	
C-1: Shared Track with RTD	

Scenario B-5 was reintroduced into the Level 3 Evaluation as the project team felt that the Northwest Quadrant (NWQ), from I-25 North to near Golden, should remain as a potential east-to-west alignment choice in the future.

For the Level 3 Evaluation, these four remaining scenarios were packaged into one ICS LPA (Scenario B-2A) with two design options (Scenarios A-5A [I-76] and B-5(NWQ)). Scenario A-5A, using the I-76 alignment, serves as a Denver metro area and Scenario B-5, with the NWQ, serves the northwest

portion of the Denver metro area. Scenario C-1, which uses portions of the RTD rail system, provides elements of a possible phasing scenario.

The selection of either east-to-west design option (C-470, I-76 or the NWQ) can logically be postponed until a future time without any effect on near-term phasing of HST construction. Further, any of the HST configurations assume connectivity to the RTD system at the North Suburban, West Suburban, South Suburban, and DIA stations. This would apply regardless of the east-to-west design option selected. Interconnectivity with central Denver is a high priority from the City and County of Denver; assuring a high level of connection between the City and a future HST system will remain a priority.

Combining the scenarios into a single ICS LPA is justified due to the fact that:

- All share the same north-to-south alignment, at approximately 190 miles between Fort Collins and Pueblo
- All share the same I-70 AGS mountain corridor alignment, at approximately 150 miles
- All share the same general station locations

Of the four finalist scenarios, Scenario B-2A on the C-470 alignment (see **Exhibit 6-2**) realized better ridership than either Scenario A-5A or Scenario C-1 and comparable ridership to Scenario B-5. Therefore, the study team determined that this scenario would serve as the logical basis as the Front Range component of the HST Vision for Colorado. It was presented to the PLT and the public for endorsement as the ICS LPA, recognizing that, as stated above, the future decision on routing an HST system east to west through the Denver metro area to the mountains could deploy any of the following options:

- **ICS LPA B-2A Base (LPA-Base).** This option uses the E-470 segment from east to west and assumes a transfer to AGS technology (Maglev) at the West Suburban Station.
- **ICS LPA B-2A with I-76 (LPA-I-76).** This option is preferred by the AGS study team because they believe it provides a more direct trip from Eagle County Regional Airport to DIA using Maglev technology. This option is modeled both with a mix of HSR and Maglev vehicles and with 100 percent Maglev vehicles for comparison

purposes as detailed under Section 6.5.2, Transportation Benefits.

- **ICS LPA B-2A with Northwest Quadrant (LPA-NWQ).** This option would use the Northwest Quadrant segment and assumes a transfer to AGS technology (Maglev) at the West Suburban Station. At the writing of the final report, this option had the least PLT support of the three. The reasons for retaining it are given below.

These three east-to-west alignment options for the ICS LPA are presented in **Exhibits 6-2 to 6-4**.

6.3.1 Description of the ICS LPA

Technology

Two technologies are carried forward in the ICS LPA: HSR and high-speed Maglev. For the purposes of service planning and OPEX estimating, the assumed HSR technology is the Siemens Velaro vehicle. The service plan is based on 17 trainsets consisting of 8 cars each. Assuming 70 seated passengers per car, each train would carry up to 560 passengers.

For high-speed Maglev, the Transrapid International (TRI) technology has been assumed. No cost estimate for Maglev vehicles is provided in the ICS.

Alignment

The general alignment for the ICS LPA is presented in Section 5, Level 2 Evaluation. During the Level 3 Evaluation, refinements were made to the alignment to reduce costs or respond to program changes, as discussed below.

North to Fort Collins

Between the Level 2 and Level 3 Evaluations, horizontal and vertical geometry changes were made to the HST alignment between Fort Collins and the North Suburban Station. As discussed above, the I-25 median between Fort Collins and the North Suburban Station is no longer available to the project. As a result, the HST alignment was moved to the east side of I-25, which caused significant changes to the vertical profile of the alignment. Costs were calculated for the ICS LPA options with double tracking for the entirety of each alignment. Compared to Level 2 costs, where the alignment was within the median, the costs for an alignment on the east side of I-25 are estimated to be \$1.375 billion greater. (As described later, value engineering of the alignment has reduced this cost increase.)

EXHIBIT 6-2: LPA-BASE

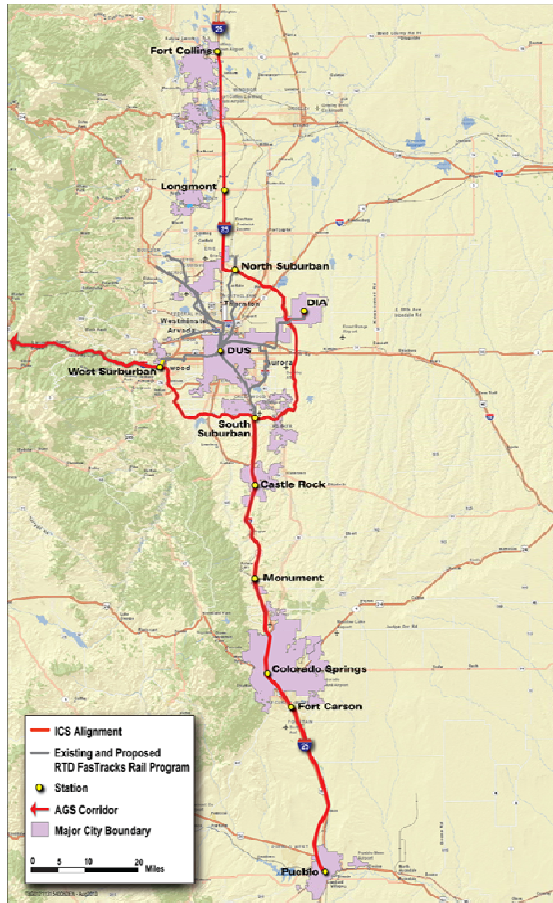
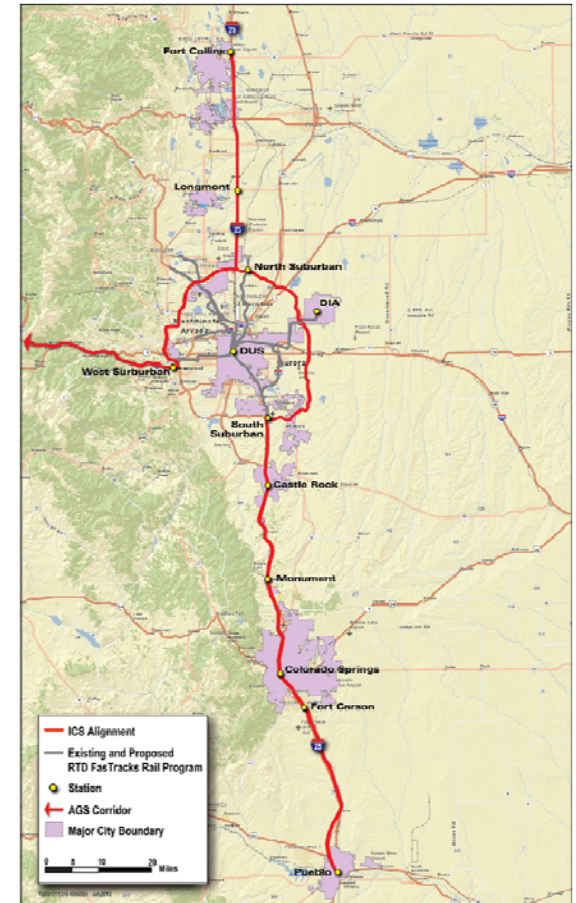

EXHIBIT 6-3: LPA-I-76



EXHIBIT 6-4: LPA-NWO



The new I-25 north alignment was then value engineered to reduce the amount of double track and elevated structures. VE cost savings are discussed under 'Impact on Cost'.

Denver Metro

The Denver Metro area alignments also were adjusted vertically between the Level 2 and Level 3 Evaluations; the horizontal alignments remained the same. The vertical changes on the alignments were primarily due to the more accurate vertical data provided by Digital Terrain Mapping (DTM). Grade-separated interchanges were analyzed in more detail to take advantage of existing terrain conditions. Because high-speed geometry is more restrictive than that of highways, the Level 2 plan to get the alignment back to grade to minimize structure costs could not be achieved in many cases due to existing site features.

South to Colorado Springs to Pueblo

Between the Level 2 and Level 3 Evaluations, horizontal and vertical geometry changes were made to the HST alignment between the South Suburban and Pueblo stations. These changes were made in order to optimize the horizontal and vertical profiles to minimize costs. In addition to determining locations where single track was possible, areas where the alignment could operate at-grade rather than on structure were identified. In the Level 2 Evaluation, elevation data was gathered from Google Earth and U.S. Geological Survey mapping to create a vertical profile. For Level 3, more accurate DTMs were used to create existing vertical profiles. From the existing profiles, proposed vertical profiles were designed to maximize the amount of new track construction on 5 feet of roadbed, minimize the amount of elevated structure and retained fill sections, and provide grades of less than 4 percent.

In the south corridors, where the HST alignment is adjacent to I-25, there are many instances of the alignment encountering an interchange where a roadway crosses over I-25. Instead of using retained fill to build the alignment to fly over the interchange as was proposed in Level 2, HST alignments in Level 3 generally are proposed to remain at-grade under the overhead bridge. This will necessitate the rebuilding of entrance and exit ramps and the overhead bridge. Other methods of constructing the

HST alignment through overhead interchanges include tunneling under entrance and exit ramps.

Stations

Station locations were further evaluated during the Level 3 Evaluation. With the selection of LPA-I-76, one additional station located at I-76/72nd Avenue is provided. Discussion of changes made to station locations is included in subsection 6.4.2. The station locations are shown in **Exhibits 6-2 to 6-4**.

Operating Strategy

The operating strategy has not changed from the recommended for Scenario B-2A made during the Level 2 Evaluation. However, the Level 3 OPEX estimate reflects several significant cost efficiencies as described in Section 6.4.

6.4 Value Engineering Inputs to the ICS LPA

Value Engineering (VE) is defined as fulfillment of the desired function at the lowest lifecycle cost. It does not eliminate project components unless they are found to not address the basic function of the project. For example, any VE proposal must maintain both the intended travel speeds and the service planning requirements of the HST Vision program.

The study team conducted VE for the HST system in order to optimize the alignment for operational efficiency and reduce the cost wherever possible.

The following VE options were evaluated:

- Single-track alignments assuming the same service plan and travel speeds
- Use of cut-and-cover tunnels or structure reconstruction versus use of flyovers to cross existing highway ramps and structures
- Reduction of the amount of ROW required
- Local participation for station funding

By contrast, cost-reduction can often eliminate scope from a project. For example, service and/or travel speed would be reduced by using a diesel versus electrified HST system.

The following cost-cutting proposals were evaluated:

- Reduced travel speed and provision of passing track only at stations

- Reduced travel speed through the use of diesel technology to eliminate electrification
- Use of dual-mode (electric/diesel) technology to allow interoperation with existing RTD track (evaluated for phasing only)

These VE options are discussed below.

VE Options 1 and 2: Single-Track Alignments

The ICS operations plan of 30-minute peak and 60-minute off-peak service would permit the use of single track in many locations. In general, single track was found to cost about 35 percent less than double track. It also offers the advantages of reduced ROW requirements, with a minimum of 30 feet in width versus 60 feet in width in urban areas and 50 feet versus 100 feet in rural areas. This reduced ROW would result in fewer impacts and improved constructability in constrained urban areas. Two basic single-track configurations were assessed:

- VE Option 1: HSR/single track where possible
- VE Option 2: HSR/passing track at stations

VE Option 1: HSR/Single Track Where Possible

The revised horizontal and vertical profiles described above in Section 6.3.1 were used to calculate costs for VE Option 1.

Changes from the Original Scenario B-2A

The original Scenario B-2A provided a double-track configuration for its entire alignment. VE Option 1 calls for the application of single track where possible and only using double track when necessary. The segments where double track is necessary would be determined by identifying locations where trains traveling in opposite directions meet within the corridor. First, a schedule is created based on the proposed operations plan. Using the proposed schedule, locations where two trains intersect can be identified. A double-track passing siding is required to be placed with its center at the location of the meet; its length is based on maximum operating speeds in the corridor.

VE Option 1 assumed no reduction to the original service plan – trains would travel at up to 220 mph using the 30-minute peak and 60-minute off peak service. The intent was to preserve the same ridership with some reduction in cost. The average percentage of double track under this scenario is 73

percent, meaning that the remaining 27 percent is single track. However, should the I-76 design option (LPA-I-76) be selected, the amount of single track can be increased to 36 percent due to the operating characteristics of that segment.

Impact on Cost

North to Fort Collins

As described above, a new I-25 north alignment was designed between Level 2 and Level 3 because of programmatic agreements made by CDOT for managed lanes in the median of I-25. The cost of a fully double-tracked section between the North Suburban Station and Fort Collins Station on an alignment on the east side of I-25 is estimated to be \$3.051 billion. By reducing the amount of double track to about 45 percent and eliminating as much elevated structure as possible, the VE cost was \$2.512 billion, a savings of \$539 million over the theoretical worst case. A majority of the cost savings is captured in Standard Cost Category (SCC) 10 – Track Structures and Track. However, the total cost is still greater by \$784 million than when the alignment was located in the median of I-25 with a cost of \$1.728 billion during the Level 2 Evaluation.

Denver Metro Area

Project costs of HST in the Denver Metro area increased as a result of receiving more accurate vertical profile information. In Level 2, it was assumed that many sections could be at-grade, but with better vertical geometry, it was determined that elevated and retained sections were necessary. While the amount of double track in the Denver Metro area remained the same in Level 2 and Level 3, the amount of at-grade track was reduced by 15 percent, and overall Denver metro area costs increased by \$2.675 billion.

South to Colorado Springs and Pueblo

Reducing the amount of double track to about 63 percent and reducing the amount of elevated track sections by 14 percent from the Level 2 to Level 3 Evaluations produced a cost savings of \$433 million. A majority of the cost savings is captured in SCC 10 – Track Structures and Track.

Impact of VE Option 1 on LPA-Base

As shown in **Exhibit 6-5**, the LPA-Base with VE Option 1 results in a capital cost of \$15.4 billion. This compares to a worst case cost of \$16.5 billion with 100 percent double track, resulting in a savings of

\$1.1 billion. However, the \$15.4 billion at Level 3 Evaluation is still \$2.0 billion more than the \$13.4 billion estimate at Level 2 Evaluation. This is due to the more detailed Digital Terrain Mapping information that resulted in the need for more elevated structure.

The estimate is for the HST system and excludes vehicles. The AGS system has been estimated separately at between \$13.5 billion and \$16.7 billion.

EXHIBIT 6-5: LPA-BASE WITH VE OPTION 1 (WITHOUT VEHICLES)

Category	Vision LPA - VE Option 1	
CORRIDOR LENGTH (MILES)		209.9
10 TRACK STRUCTURES & TRACK	\$	5,314.33
20 STATIONS, TERMINALS, INTERMODAL	\$	350.00
30 SUPPORT FACILITIES: YARDS, SHOPS, ADMIN. B	\$	243.05
40 SITEWORK, RIGHT OF WAY, LAND, EXISTING IMPROVEMENTS	\$	1,616.77
50 COMMUNICATIONS & SIGNALING	\$	420.59
60 ELECTRIC TRACTION	\$	1,017.24
PROFESSIONAL SERVICES	\$	2,285.30
UTILITY RELOCATION	\$	379.59
ENVIRONMENTAL MITIGATION	\$	224.05
CONTINGENCY	\$	3,555.28
SUB-TOTAL SCENARIO COST (in Millions)	\$	15,406.19

Impact on Operations

VE Option 1 has been configured to have no negative impact on travel speeds or the service plan.

Recommendation

This option has been carried forward into the ICS LPA.

VE Option 2: HSR/Passing Track at Stations

As with VE Option 1, revised horizontal and vertical profiles were used to calculate costs for VE Option 2.

Changes from the Original Scenario B-2A

The original Scenario B-2A provided a double-track configuration for its entire alignment. VE Option 2 calls for the construction of double track only at the HST stations – a total of 0.5 mile of double track centered on the stations. As a result, approximately 95 percent of the guideway would be single track and 5 percent double track. Limiting passing track to the station areas requires that HST trains be “held back” at the stations while the train traveling in the opposite direction passes.

Following FRA guidance on the preparation of passenger train schedules, the Train Performance Calculations modeled trains being “held back” at stations by adding a “pad” to the base travel time. FRA’s manual on Railroad Corridor Transportation Plans states that a schedule must have a pad to reflect real-world operating conditions, such as trains operating in a single-track corridor. The manual gives a formula for calculating pad based on the number of meets with other passenger trains, the distance between passing tracks, average speed, and general increases in train performance run time due to human operation, delays, congestion, and weather conditions. Holding back the trains at the stations dramatically increases travel time and reduces projected ridership by approximately 30 percent.

Impact on Cost

As shown in **Exhibit 6-6**, VE Option 2 significantly reduces capital cost, from \$16.5 billion with full double track to \$11.5 billion, a savings of \$5 billion. This estimate excludes vehicles.

EXHIBIT 6-6: LPA-BASE WITH VE OPTION 2 (WITHOUT VEHICLES)

Category	B2A VE Opt 2	
CORRIDOR LENGTH (MILES)		209.8
10 TRACK STRUCTURES & TRACK	\$	3,725.00
20 STATIONS, TERMINALS, INTERMODAL	\$	350.00
30 SUPPORT FACILITIES: YARDS, SHOPS, ADMIN. B	\$	243.05
40 SITEWORK, RIGHT OF WAY, LAND, EXISTING IMPROVEMENTS	\$	1,184.45
50 COMMUNICATIONS & SIGNALING	\$	341.96
60 ELECTRIC TRACTION	\$	827.06
PROFESSIONAL SERVICES	\$	1,701.24
UTILITY RELOCATION	\$	282.57
ENVIRONMENTAL MITIGATION	\$	166.79
CONTINGENCY	\$	2,646.64
TOTAL SCENARIO COST (in Millions)	\$	11,468.75

Impact on Operations

VE Option 2 dramatically increases travel times. For example, the travel time from Colorado Springs to DIA would increase from 52 minutes with the original double track configuration to 1 hour 32 minutes with VE Option 2, an increase of 77 percent. As a result, projected ridership and revenue went down sufficiently to degrade the operating ratio to below 1.0, which does not support the project Purpose and Need.

Recommendation

Due to the negative impact on ridership and revenue, VE Option 2 was set aside.

VE Option 3: Local Participation for Station Funding

Changes from the Original Scenario B-2A

The Benefit/Cost Analyses suggests that the HST stations will have a local benefit of approximately \$600 million to \$700 million per station.

Consequently, it is reasonable to assume that local governments would be responsible for funding the local secondary stations. This would be considered the local governments' contribution to the project. It would also provide an incentive for developing cost-effective stations. Currently, the project carries up to \$25 million per secondary station in 2013 dollars.

Impact on Cost

VE Option 3 would not reduce the cost of the ICS LPA. However, the cost of the HST stations would be funded and financed by local government.

Impact on Operations

This option has no anticipated impact on operations.

Recommendation

VE Option 3 is carried forward into the Financial Planning assumptions for the ICS LPA.

VE Option 4: Use of Dual-Mode Technology

Changes from the Original Scenario B-2A

The ICS LPA remains technology neutral because either HSR or Maglev could eventually be incorporated into the system, depending on market conditions. It should be noted that, at this point in the planning process, HSR technology appears to cost \$10 million to \$15 million per mile less to construct than Maglev in the ICS study area.

However, since a first phase of the project would not be ready to bid for at least 8 years, it is felt that the technology recommendation should remain open to allow for technological advancements that could result in a more competitive position between steel wheel and Maglev technologies.

VE Option 4 calls for substituting the high-speed systems with a lower-speed dual-mode technology that:

- Could interoperate with RTD's rail system
- Would be lower cost due to the elimination of catenary

- Would allow the use of more single track than HSR allows due to lower, 110-mph travel speeds

The advantage of this concept is that it facilitates additional usage of RTD rail transit. Further, it would provide a 'one seat' ride from Fort Collins to Pueblo. The disadvantage is that dual-mode technologies do not perform at the same speeds as HSR. The Stadler GTW 2/6 vehicle, shown below, has a top speed of 110 mph, which is the value that was used in ridership modeling.

It should also be noted that the FRA has allowed waiver of its collision criteria for these vehicles, based on the use of crash energy management techniques, allowing them to operate in alignments normally requiring FRA-compliant vehicles, defined as vehicles with 800,000 pounds of "buff strength."

Properties that have successfully received FRA waivers include:

- Trenton, NJ – LRT/DMU operation over freight line
- Austin, TX – LRT/DMU operation over freight line
- Oceanside, CA – LRT/DMU operation over freight line
- San Diego, CA – Electric LRT operation over freight line
- San Jose, CA – Approved Joint Operation of Electric HSR and Electric CRT with temporal freight operation

Nonetheless, there are still challenges with dual-mode technologies. VE Option 4 would require further engineering modifications of RTD existing systems to assure that the selected dual-mode technology that is selected can operate within the tight curves in RTD's Southeast LRT guideway, that catenary required by both vehicles are compatible



with pantograph geometry, and that the existing LRT station configuration is compatible or can be modified to be compatible with the dual-mode vehicles. Lastly, some modifications to the signal systems may be required, although they are not expected to render VE Option 4 infeasible.

Impact on Cost

In general, the cost of the dual-mode starter system is about one half the capital cost of the full HSR system, although there is some variation depending on the segment being considered.

Impact on Operations

Although the cost savings appear to be promising, the reduced travel speeds with the 110-mph technology have a significant impact on projected ridership. As discussed in more detail in Section 8, Implementation Plan, the ridership realized with this VE option is less than one-half that of the HSR. As a result, the project would not produce an OPEX ratio above 1.0 and thus did not meet the project Purpose and Need.

Recommendation

Due to the negative impact on ridership and revenue, VE Option 4 was set aside.

6.4.2 Other Modifications to the ICS LPA at Level 3

Station Locations

Station locations were modified in Level 3 to account for the new alignments north and south of Denver. The following stations shifted location to better fit the system's proposed vertical profile:

- The South Suburban Station was moved 1.2 miles south of its Level 2 location
- The Castle Rock Station was moved 1.16 miles south of its Level 2 location
- The Monument Station was moved 0.65 mile north of its Level 2 location
- The Colorado Springs Station was moved 0.86 mile north of its Level 2 location
- The Fort Carson Station was moved 1.14 miles south of its Level 2 location
- The Longmont/Berthoud Station was moved 2.31 miles south of its Level 2 location

The Pueblo, North Suburban, DIA, Fort Collins, and I-76 at 72nd Avenue stations remained in the same locations as in Level 2.

Two new stations were added as MOS-only stations. Loveland, located approximately 10.26 miles north of the Longmont/ Berthoud Station and 11.40 miles south of the Fort Collins Station, was added as a possible MOS end-of-line station for the north alignment. Briargate, located approximately 10.88 miles south of the Monument Station and 9.56 miles north of the Colorado Springs Station, was added as a possible MOS end-of-line station for the south alignment.

Specifics on the station locations used for travel demand modeling are provided in the ICS Conceptual Plan Set included as Appendix G.

6.4.3 OPEX Cost Reductions

Having remained constant from the Level 2 Evaluation, the service plan is based on an 18-hour daily span of service, 7 days per week. For highest-demand days (considered Monday through Friday for the Front Range corridor and Thursday through Sunday for the mountain corridor), 30-minute frequencies are assumed for 6 hours per day, with hourly service assumed for the remaining 12 hours. For lighter days (weekends for Front Range corridor, Monday through Wednesday for the mountain corridor), an hourly frequency is assumed for the bulk of the day.

While service plan refinements were considered in Level 3 Evaluation, it was ultimately determined that the assumed level of service already is streamlined. Therefore, no adjustments were made to further reduce or refine service levels at the Level 3 Evaluation.

Value Engineered Operations and Maintenance Costs and Organizational Structure

While previous OPEX estimates were based on applying a single unit cost per train-mile, an operations and maintenance (O&M) cost model was subsequently developed and employed. Elements of the O&M cost model were based on costs and productivity information from the Utah Transit Authority (UTA) and other peer system commuter rail data, adjusting those unit costs to account for differences in the transit modes under consideration. UTA was used as the benchmark

partner because their rail operation is among the most cost-effective in the nation.

The O&M cost model reflects the following assumptions to reduce the costs of HST service:

- Relatively flat organizational structure with a compact general administrative labor force
- Managers/supervisors with many duties and responsibilities, thus avoiding multiple layers of management
- Two-person crews on each train
- Contracting of certain functions (e.g., car cleaning, station and train security, ROW maintenance)
- Ownership of ROW to eliminate "use of ROW" costs

Another area that led to significant reductions in the estimated O&M costs was propulsion assumptions. A power analysis prepared for the AGS study suggests that propulsion power is related more to route miles (distribution) than to usage (consumption) (*AGS Feasibility Study Subtasks 9.5 & 9.9 Revision 2*, August 26, 2013). The impact of this finding is reduced overall costs, with greater savings in costs for operating the full system, relative to phasing options.

6.5 Consequences of Implementing the ICS LPA

6.5.1 Public Benefits

Evaluation of the Public Benefits criterion at Level 3 is the same as for Level 2. However, due to revisions to the ICS LPA, some of the results have changed slightly, as discussed below under two categories:

- Project Purpose and Need
- Level of Public and Agency Support

Purpose and Need

The ICS LPA meets the project Purpose and Need the best of any of the scenarios evaluated. The ICS LPA offers statewide social, environmental, and economic benefits that are greater than the capital and operating costs of its implementation, with a final Benefit Cost ratio of 1.7. The Purpose and Need Statement included in Section 2 lists five needs.

Exhibit 6-7 validates that the selected ICS LPA fulfills each of these needs.

Public and PLT Support

The degree of public support statewide for the HST Vision program appears to be positive, but how the system will be funded presents concerns. In general, support has been strong based on the PLT and public workshop processes. The ICS LPA was selected in part due to the greater support received for alignments that travel around the Denver metro area rather than through the urban area. A major element of support for alignments around rather than through Denver was the recognition that the alignments through Denver had high environmental and community impacts, and in many locations these impacts were borne disproportionately by minority and low-income communities. The PLT also recognized that the environmental process would likely be prolonged given the likelihood for significant adverse impacts and the need for community involvement and input along the densely populated alignments.

The PLT has offered the following insight regarding implementation of a first phase of the HST Vision:

- The first phase needs to be successful to attract support for future phases.
- The first phase needs to have wide geographic public support in order to gain commitment for a new funding source (likely a tax initiative).
- Although they are easier to fund, smaller phases (for example, North Suburban to Fort Collins) will realize insufficient public monetary support.
- Given the above, a larger first phase is believed to be needed to gain the needed level of public support and enthusiasm.
- While the majority of the population and ridership is in the front range of Colorado, the mountain corridor provides a visionary segment that may receive a high level of public support in the future.
- Within Front Range communities, there is a need to maintain collaboration and a common vision to position for future federal funding. Communities need to believe in the broad program to feel confident that investment

EXHIBIT 6-7: ICS LPA'S FULFILLMENT OF THE PROJECT PURPOSE AND NEED

Need	Is the Need Fulfilled by the LPA?
1. Address the mobility demands of future populations	<ul style="list-style-type: none"> ▪ Yes. The ICS LPA will provide as many as 18.4 million riders in 2035, or about 61,333 riders per day. This is the highest level of ridership of any of the Scenarios investigated. ▪ ICS LPA will address, in part, projected severe highway congestion between Fort Collins and Colorado Springs as the State's population increases from 5 to 8 million people.
2. Improve mobility and system capacity through provision of a travel option	<ul style="list-style-type: none"> ▪ Yes. Of the 18.4 million annual riders in 2035, about 80 percent of the trips are inter-city trips, demonstrating the ability of the system to connect <i>interregional</i> business and tourism travel. ▪ The ICS supports local transit investments, especially RTD's FasTracks system in metro Denver, by connecting new out-of-area riders to existing local transit networks. ▪ The ICS LPA will afford those who do not want to drive, cannot drive, or those who do not have an automobile a different travel option. ▪ Increasing transit options (in lieu of or in addition to highway options) has been identified as a high priority for citizens of Colorado in state-wide transportation planning efforts.
3. Enhance economic growth and development through improved connectivity	<ul style="list-style-type: none"> ▪ Yes. The ICS LPA will reduce Vehicle Hours Travelled (VHT) by 1,848,000 hours per year, resulting in a time savings of \$735 million over 30 years. ▪ Development around the proposed HSIPR stations is project to increased assessed valuation by \$69 billion. ▪ The provision of a high-speed travel option will facilitate commerce and personal commuting between Fort Collins and Pueblo, a distance of 190 miles. ▪ The ICS LPA will provide travel times that will average one half that required by automobiles virtually every origination and destination in the ICS study area.
4. Improve the State's environmental quality and energy efficiency	<ul style="list-style-type: none"> ▪ Yes. The ICS LPA-Basic will eliminate 550,370,000 Vehicle Miles Travelled (VMT) annually resulting in benefits that are valued at \$5.3 billion over 30 years. ▪ The ICS LPA-Basic will provide the opportunities for TOD around 12 major stations along the Front Range of Colorado. ▪ The ICS LPA will result in 27,519,000 less gallons of petroleum products annually based on an average consumption of 20 miles per gallon.
5. Provide economic benefits sufficient to attract new funding sources	<ul style="list-style-type: none"> ▪ To Be Determined. The ICS LPA provides an OPEX ratio that is sufficient to attract new funding sources. However, implementing the ICS LPA will require a voter commitment for a major new funding source. With this voter commitment, the ICS LPA is anticipated to be able to qualify for federal funding if and when these funds become available.

improves local communities and not just the largest population centers.

- Any first phase must connect to DIA.
- A connection to Denver Union Station appears to be less important to the overall system's success. This is likely because RTD is more cost-effective in serving intra-city trips and provides more options (stations). Providing HST service to the RTD perimeter allows riders to choose a transfer location closer to their final destination, for example, using the South Suburban Station to access employment centers such as the Denver Tech Center.

Livable Communities

- As reported in the Level 2 Evaluation, all of the scenarios support livable communities and Transit Oriented Development (TOD), with only minor differences in benefits among the scenarios. As updated for the Level 3 Evaluation, implementation of the LPA-Base is estimated to generate approximately \$6.9 billion in real estate development. The comparative value for the HST Vision program (ICS + AGS projects) is \$10.6 billion.

Employment

- The LPA-Base is projected to result in 118,500 construction jobs plus (assuming an employment multiplier of 2.0) an additional 118,500 temporary spin-off jobs during its 10-year construction period. As discussed in Section 8, Implementation Plan, implementation of separate phases of the project would have proportionately smaller employment benefits.
- New operational and related permanent spin-off jobs are estimated at 1,400 and 700, respectively (assuming an employment multiplier of 1.5).

6.5.2 Transportation Benefits

High-level schematic diagrams of the alignments for each of the ICS LPA options are shown in **Exhibit 6-8**.

System Ridership and Ticket Revenue

System ridership and revenue were estimated based on the assumption that the ICS and the AGS would work as a statewide HST Vision program. Definitely splitting out the ridership between the two projects is difficult because, to some extent, each project supports the other. For example, ridership to the mountains is higher if people from Pueblo, Colorado Springs, and Fort Collins can access the system and travel west. Likewise, ICS ridership is higher if Front Range riders can travel to the mountains. When the LPA-Base includes the AGS system (HST Vision program), the combined project has an estimated 18 to 19 million riders per year in 2035, with corresponding revenues from \$335 million to \$380 million annually. In general, the ICS portion of the total ridership is 70 to 80 percent, and the AGS portion is 20 to 30 percent.

EXHIBIT 6-8: SCHEMATIC DIAGRAMS OF THE ALIGNMENTS AND RIDERSHIP MARKETS FOR THE ICS LPA OPTIONS

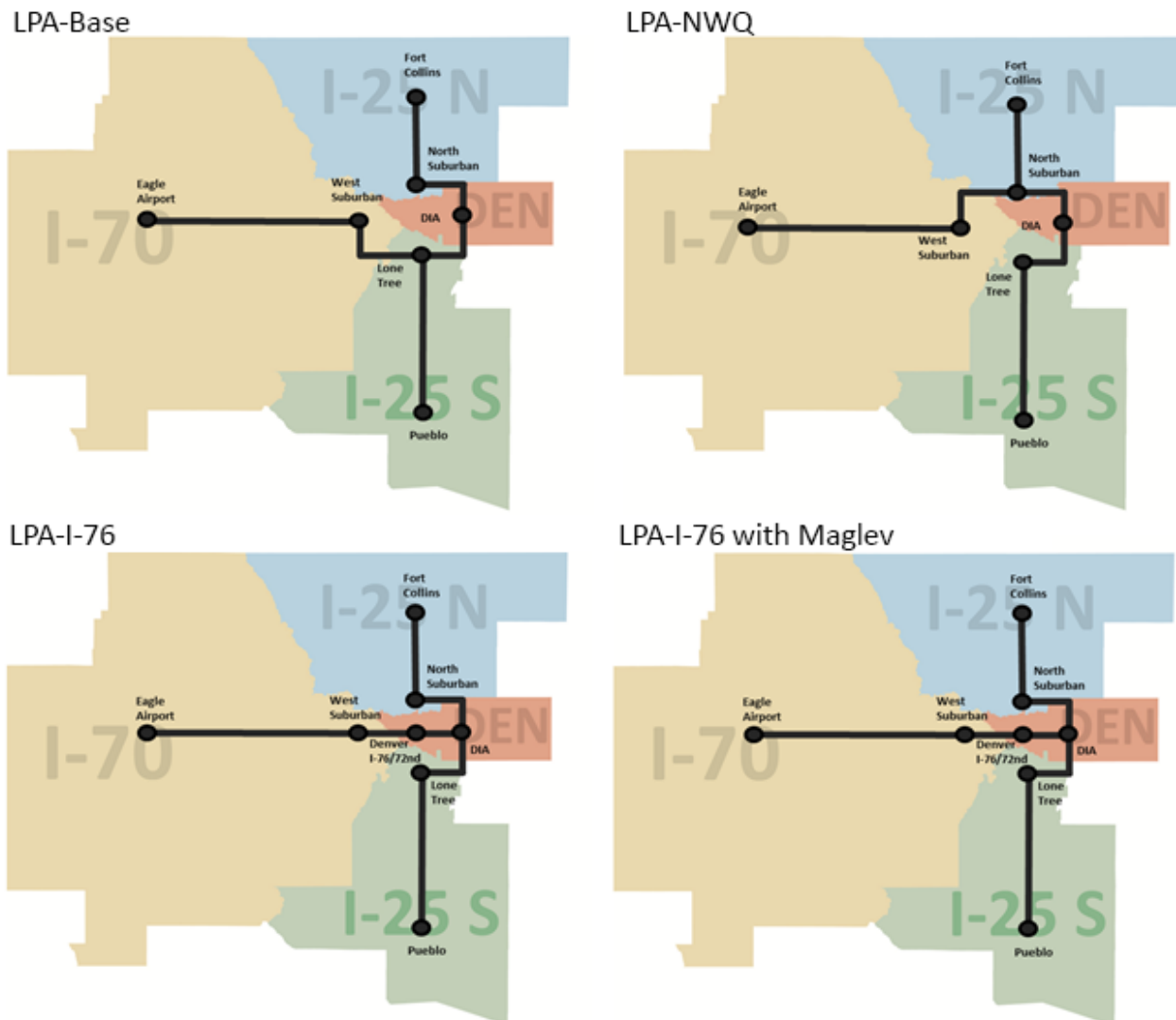

Ridership and ticket revenue was estimated for each of the ICS LPA options (LPA-Base, LPA-I-76, LPA-NWQ, and LPA-I-76 Maglev). As shown in **Exhibit 6-9**, the differences in ridership and revenue are modest. LPA-NWQ realizes ridership and revenues that are slightly lower than LPA-Base; this is because travel between the strongest market south of Denver and the mountain communities requires longer travel times and higher fares. As shown later, this option also has higher capital costs than the other options.

EXHIBIT 6-9: 2035 RIDERSHIP FORECAST SUMMARY FOR THE HST VISION PROGRAM

Scenario	Ridership (millions/year)	Ticket Revenue (millions/year)
LPA-Base	18.3	\$344
ILPA-I-76	17.9	\$353
LPA-NWQ	18.1	\$335
LPA-I-76 Maglev	19.1	\$381

By comparison, LPA-I-76⁴ realizes approximately 2 percent lower ridership than LPA-Base even though this option provides a more direct connection between DIA/Denver metro and the mountain corridor (as illustrated in **Exhibit 6-8**). This is mainly due to two reasons. First, the transfer involved at DIA between the ICS and the AGS systems negatively impacts ridership. Second, travel from south of Denver to the mountains and vice versa requires longer time and higher fares due to longer distances compared to LPA-Base. However, the higher fares for some of the major markets translate to marginally higher total revenue for the LPA-I-76 option compared to the LPA-Base option.

If LPA-Base deploys an all-high-speed Maglev fleet, projected ridership and revenue increase by about 4.4 percent and 10.7 percent, respectively, compared to LPA-Base with an all-HSR (steel wheel/steel rail) fleet. This is due to faster travel times in the ICS corridor and between the ICS and AGS corridors, especially for the longer-distance (i.e., higher-fare) markets, resulting in disproportionately higher revenue. Conversely, the use of all-Maglev technology increases the capital cost of the ICS

alignments by approximately \$10 million to \$15 million per mile depending on the location.

Ridership and Revenue by Market

The ICS study area was divided into four high-level mutually exclusive and collectively exhaustive markets in order to more systematically analyze the ridership and revenue patterns based on geographic location. The four market areas are: mountain corridor (I70), I-25 north of the Denver metro area (I25N), I-25 south of the Denver metro area (I25S), and Denver metro area including DIA (DEN). Each station was assigned to one of these four markets based on its location, and ridership and revenue were subsequently aggregated to each market pair. **Exhibit 6-10** shows these four markets and the corresponding stations; **Exhibit 6-11** and **Exhibit 6-12** present ridership and revenue, respectively, by market pair for each option.

It should be noted that revenue differences may be more or less pronounced compared to the corresponding ridership differences among various options, as seen in some instances comparing **Exhibits 6-11** and **6-12**. This is due to the differential distance distribution of the various station pairs and the fact that the station pair level fares for HST service are calculated based on distances. In other words, similar ridership changes for a long- and short-distance station pair will be accompanied by a higher absolute revenue change for the longer-distance station pair (e.g., Fort Collins to Pueblo: a station pair in the I25N-I25S market, as shown in **Exhibit 6-10**) compared to the shorter-distance station pair (e.g., Fort Collins to North Suburban: a station pair in the I25N-I25N market, as shown in **Exhibit 6-10**).

For example, although LPA-I-76 has lower ridership than LPA-Base, it generates higher revenue. This is because it produces disproportionately higher longer-distance trips (with higher fares) compared to LPA-Base, resulting in higher revenue. To illustrate this at the market level, the ridership decrease of about 72 percent (0.86 million versus 3.03 million riders, as shown in **Exhibit 6-11**) for the I70-I25S market between LPA-Base and LPA-I-76 is accompanied by a disproportionately lower (58 percent) revenue increase (\$78.67 million versus \$32.48 million, as shown in **Exhibit 6-12**).

⁴ Assumes high-speed Maglev technology in the mountain corridor to the Denver metro area and DIA.

EXHIBIT 6-10: I70, I25N, I25S AND DEN MARKETS AND THEIR STATIONS

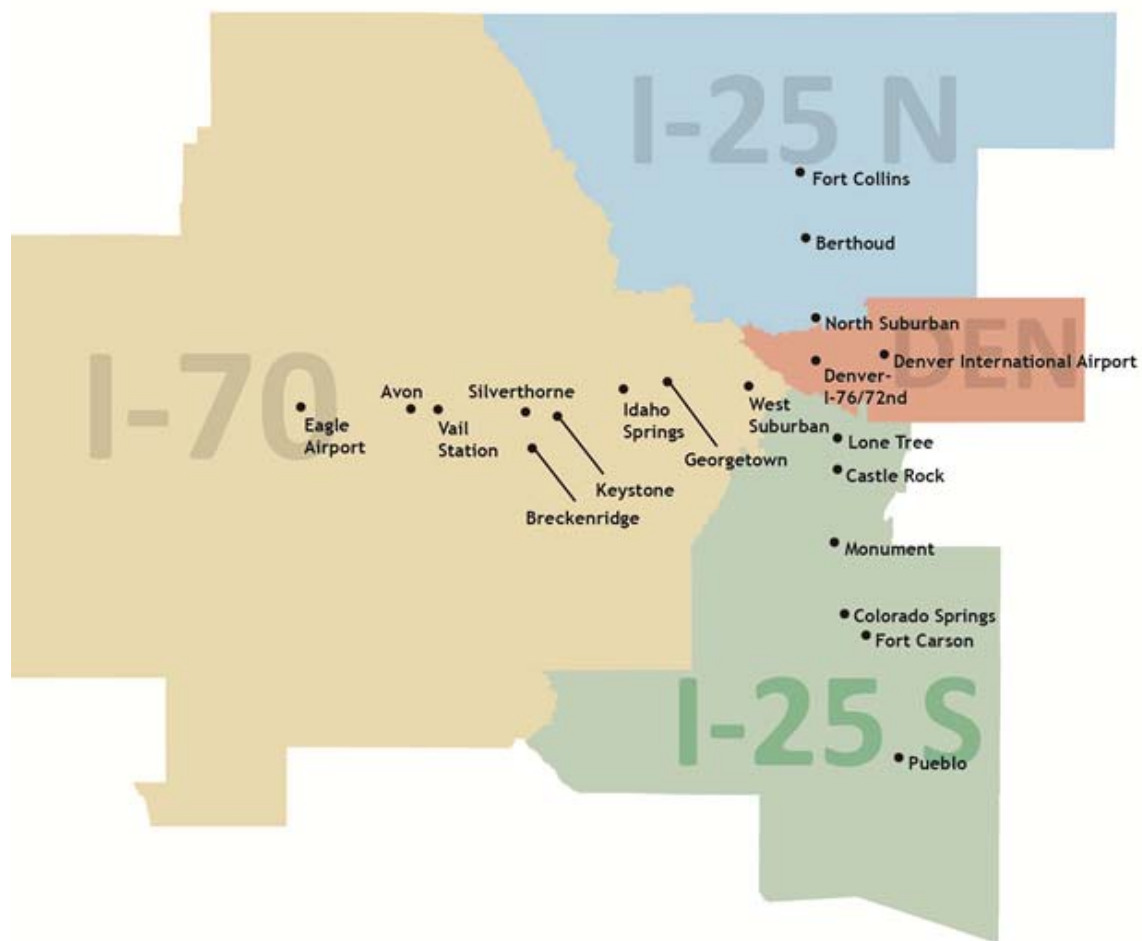

EXHIBIT 6-11: 2035 RIDERSHIP (MILLIONS) BY MARKET

Market Pair	LPA-Base	LPA-I-76	LPA-NWQ	LPA-I-76 Maglev
I70-I70	2.19	2.12	2.17	2.12
I70-I25N	0.67	1.09	2.10	1.16
I70-I25S	3.03	0.86	0.42	0.95
I70-DEN	0.46	1.57	0.52	1.50
I25N-I25N	0.89	0.61	1.10	0.64
I25N-I25S	1.86	1.77	1.44	2.04
I25N-DEN	2.35	2.59	2.48	2.77
I25S-I25S	4.35	4.41	5.04	4.64
I25S-DEN	2.48	2.86	2.86	3.27
DEN-DEN	0	~0	0	~0
Total	18.3	17.9	18.1	19.1

EXHIBIT 6-12: 2035 REVENUE FORECASTS (MILLIONS 2012 \$) BY MARKET

Market Pair	LPA-Base	LPA-I-76	LPA-NWQ	LPA-I-76 Maglev
I70-I70	\$ 39.41	\$ 40.42	\$ 41.34	\$ 40.42
I70-I25N	\$ 24.50	\$ 35.12	\$ 55.41	\$ 37.25
I70-I25S	\$ 78.67	\$ 32.48	\$ 17.65	\$ 36.01
I70-DEN	\$ 17.33	\$ 48.05	\$ 20.30	\$ 47.44
I25N-I25N	\$ 9.44	\$ 6.44	\$ 13.65	\$ 6.72
I25N-I25S	\$ 54.91	\$ 52.34	\$ 45.07	\$ 60.68
I25N-DEN	\$ 24.90	\$ 33.20	\$ 28.24	\$ 35.74
I25S-I25S	\$ 49.54	\$ 49.06	\$ 57.89	\$ 52.59
I25S-DEN	\$ 45.57	\$ 55.77	\$ 55.35	\$ 64.13
DEN-DEN	-	\$ 0.01	-	\$ 0.01
Total	\$ 344.28	\$ 352.89	\$ 334.90	\$ 380.98

The market-level analysis provides further insight into the ridership and revenue distribution. Generally, the ICS area along the I-25 corridor has higher ridership and revenue than the mountain corridor along I-70 due to the presence of several higher-population and employment centers, including the Denver metro area. With few exceptions, markets with at least one end in I25S consistently realize high ridership and revenue.

For all the LPA options, the I25S-I25S market (which includes all the stations from Lone Tree to Pueblo) has relatively high ridership compared to other markets. However, because the station pairs in this market are of relatively shorter distances compared to those of other markets (I70-I25S and I25N-I25S), the ticket revenue is also lower. For the station pairs in this market, rail service constitutes a fairly competitive travel mode compared to auto usage – much more so than in the other markets. This market also has major population centers, including Colorado Springs, the second largest metro area in Colorado; Pueblo; and many of the metro area’s southern suburbs, including Lone Tree and Castle Rock. In addition, high future population growth is expected south of Denver. By comparison, I25N-I25N (which includes all the stations from Fort Collins to the North Suburban Station) generates low ridership and revenue. This market consists of few stations and includes station pairs with the shortest relative distances, resulting in shorter trips and therefore lower revenue.

The I70-DEN market represents a relatively low ridership market in the LPA-Base and LPA-NWQ options. In part, this is because the DEN market consists only of the DIA Station (there is no I-76/72nd Street Station in these options, as seen in **Exhibit 6-8**). In addition, travel times and distances between DEN and I70 are higher due to the significantly longer beltway alignment for these options (as seen in **Exhibit 6-8**). This is in contrast to the more direct alignment to DEN station(s) through the metro area for the LPA-I-76 and LPA-I-76 with Maglev options, both of which also include the I-76/72nd Street Station, increasing the potential ridership and revenue to DEN. The I70-I70 market (which includes all the stations from Eagle County Regional Airport to the West Suburban Station) also exhibits generally lower ridership than the ICS markets (on or along I-25) due to the absence of major population and employment centers.

The I70-I25S market is strong in the LPA-Base Option due to a direct route (as seen in **Exhibit 6-9**) that provides lower travel times and distances between the station pairs in the I70 and I25S markets compared to other options. In addition, it attracts the recreational travelers to the mountains from the southern suburbs and other major population centers south of the Denver metro area. This market also has the highest ticket revenue (followed by the I25N-I25S market) of all the LPA-Base markets as it includes many of the longer-distance station pairs. In contrast, the I70-I25S market generates low ridership for all other options, where the routes between this market pair are always longer because they go through the beltway via DIA (as seen in **Exhibit 6-9**), which also involves a transfer at DIA. This is especially true for the LPA-NWQ option where the connection between the I70 and I25S markets is even longer as the proposed alignment goes through the NWQ to DIA in addition to the beltway (as seen in **Exhibit 6-9**), resulting in significantly higher travel times and distances. By comparison, the I70-I25N market is fairly strong in the LPA-NWQ option, but exhibits relatively lower ridership in all other options. This is because LPA-NWQ offers a direct connection between the station pairs in the I70 and I25N markets. In all other options, travel between these markets requires long distances around the beltway and a transfer at DIA, resulting in longer travel times and higher fares. Due to higher fares for its station pairs (because of relatively long distances) this market generates disproportionately higher revenue.

Station Boardings

Exhibit 6-13 shows the annual boardings in 2035 at each station for all the LPA options. An analysis of the station boardings supports the ridership observations made in the market-level ridership analysis, and in some cases provides new insights into the ridership distribution because it describes patterns at a disaggregate station level. Station boardings are highest closest to the metro areas of Denver, Fort Collins, and Colorado Springs, or areas with high population and employment concentrations. These metro areas are along the I-25 corridor, which generally has higher ridership, as noted in the market-level analysis. DIA realizes the highest station boardings in all options due to its proximity to a major metropolitan area and international airport.

EXHIBIT 6-13: 2035 STATION BOARDINGS FOR THE HST VISION PROGRAM

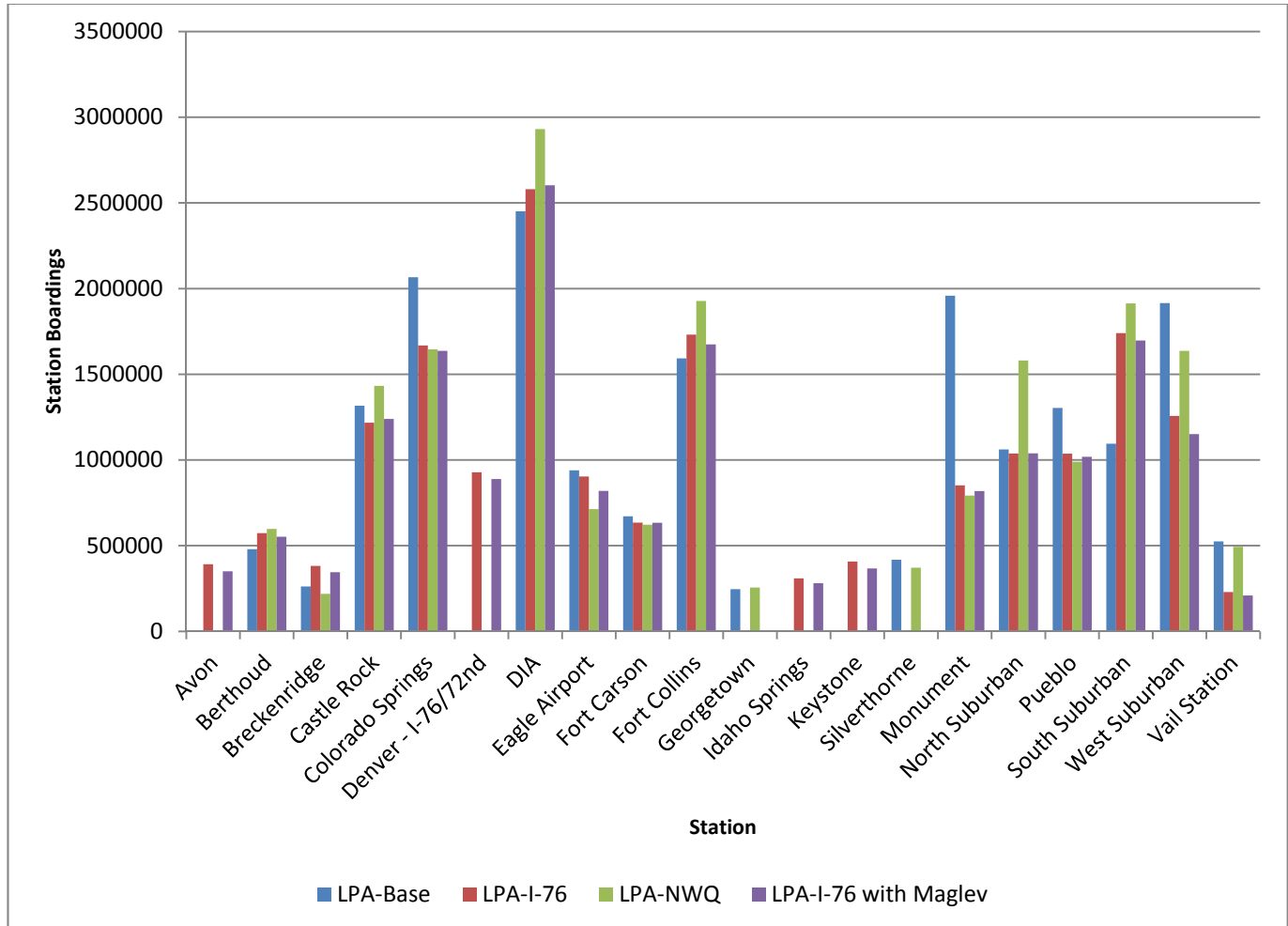

Segment Volumes

Exhibit 6-14 presents the segment volumes for HST service in 2035 for all LPA options. These volumes provide useful insights in comparing expected ridership and available seating capacities. In general, segment volumes are higher along the I-25 corridor than the I-70 corridor and increase for segments closer to the Denver metro area. This is because most trips either begin or end in the Denver metro area, or pass through the Denver area on the way to destinations. In particular, the highest volumes are for the segments south of Denver, between Lone Tree and Colorado Springs. This distribution is expected given that I25S markets consistently represent strong markets in all options.

The Breckenridge-Silverthorne segment in the LPA-Base and LPA-NWQ options has significantly lower segment volumes than the others due to the low frequency of service between Breckenridge and other stations and a forced transfer at Silverthorne

for trips made to/from Breckenridge and stations west of Silverthorne.

A few overall conclusions can be drawn from the analysis of ridership and revenue for the LPA options:

- Ridership and revenue in the I-25 corridor is generally higher compared to the I-70 corridor.
- Ridership increase/decrease may not be accompanied by proportional revenue increase/decrease at the station/market-pair level due to the use of distance-based fares.
- Market pairs with at least one end in the I25S market consistently have the strongest ridership and revenue. The strongest market pair varies depending on the option under consideration.
- Although the LPA-I-76 Maglev option has the highest overall modeled ridership, it is not highest for all market pairs. Varying alignments represent trade-offs; in some options, certain markets are served better than others.

EXHIBIT 6-14: 2035 SEGMENT VOLUMES FOR THE HST VISION PROGRAM

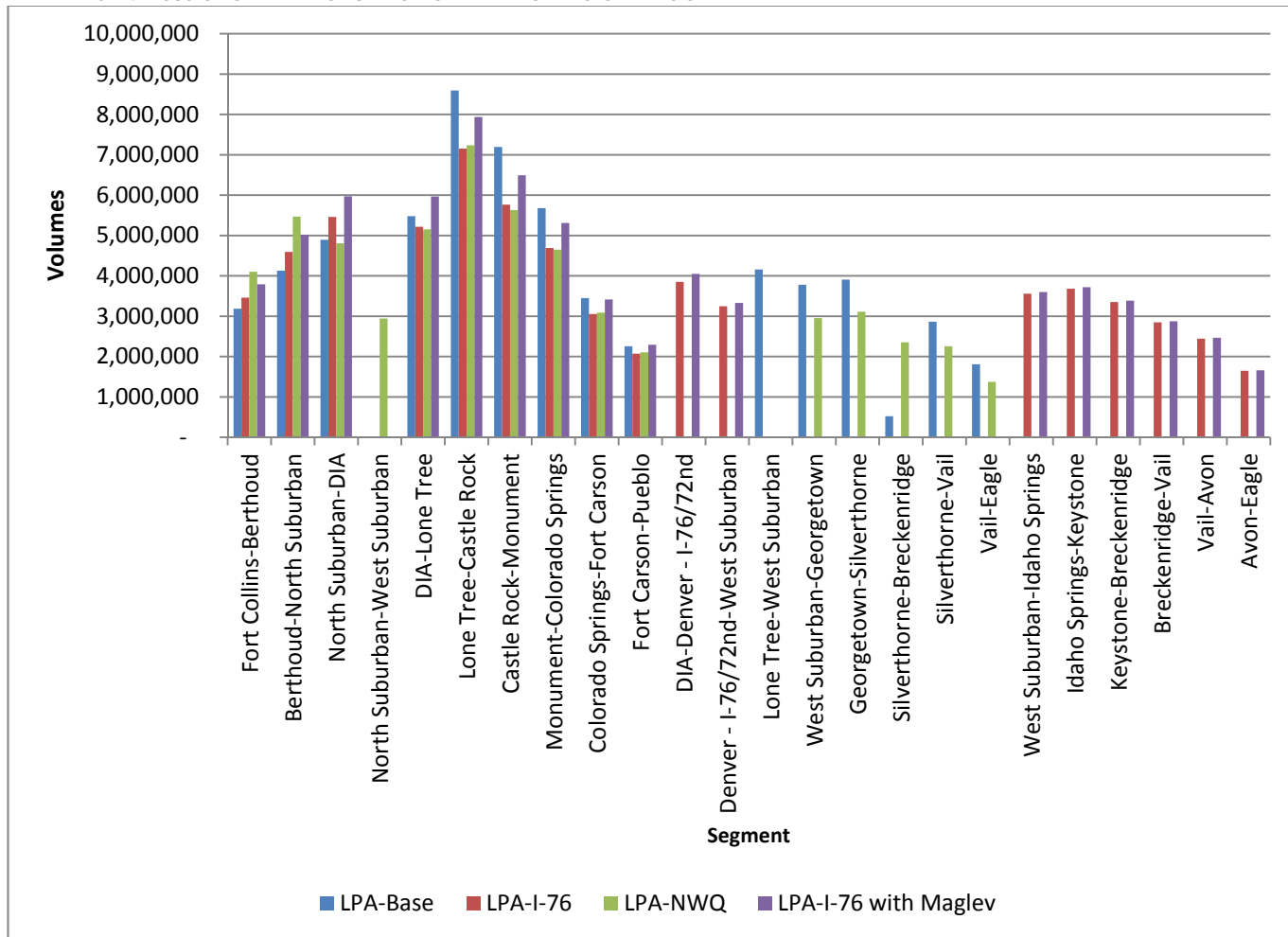

Vehicle Miles Traveled/Vehicle Hours Traveled Reductions

Reduction in VMT and VHT were calculated for all LPA options. To calculate reduction in VMT, the distances of the automobile portions of the trips (auto access and egress to/from train stations) for all diverted train trips were subtracted from the end-to-end distances for the corresponding automobile trips that would occur if the same trip were made by auto. To calculate VHT, the total times for end-to-end (trip origin to trip destination) train trips were subtracted from the end-to-end times for the corresponding automobile trips that would occur if the same trip were made by auto.

Exhibit 6-15 details the VMT and VHT savings for each option.

EXHIBIT 6-15: VMT AND VHT REDUCTIONS (MILLIONS) FOR THE HST VISION PROGRAM

	LPA-Base	LPA-I-76	LPA-NWQ	LPA-I-76 Maglev
VMT Reduction	550.4	537.5	526.2	575.9
VHT Reduction	1.85	1.53	1.73	2.19

As evident in Exhibit 6-15, LPA-I-76 Maglev has the highest VMT and VHT reductions, followed by the LPA-Base, LPA-I-76, and LPA-NWQ options. Although the results vary by scenario due to differences in diverted ridership from automobile to train, it is important to note that VMT and VHT reductions do not strictly correlate to ridership and revenue. Riders diverting for longer trips (in terms of distance and time) results in a proportionally higher reduction in VMT/VHT than the same number of riders diverting for relatively shorter trips.

Revenue Maximizing Analysis

As mentioned previously, an unconstrained revenue-maximizing analysis was performed for the LPA-Base option as part of the Level 3 Evaluation. The revenue-maximizing analysis determined the per-mile fare that maximizes the intercity revenue for proposed train service. Given that intercity long-distance travel constitutes more than 80 percent of the ridership and revenue, the revenue-maximizing analysis was only performed for the intercity travel market. Subsequently, the revenue-maximizing per-mile fare was used for the short-distance intra-urban and airport choice markets (these two markets are described in more detail in Appendix D, ICS Demand Forecast Model Documentation), in addition to the intercity market in all of the Level 3 LPA options (described above).

To identify the revenue-maximizing fare, per-mile train fares were varied in +/-5 percent (\$0.0175 per mile) increments to +/-50percent from the Level 2 fare of \$0.35 per mile.

Exhibit 6-16 graphically presents the results of the revenue-maximizing analysis for the intercity travel markets.

As expected, with the increase or decrease in train fare, intercity train ridership also increases or decreases. However, at the revenue-maximizing fare level, the ticket revenue generated is the highest, and any further increase or decrease in fare levels from the revenue-maximizing point is accompanied by a corresponding reduction in revenue. As the fare decreases, the slope of the ridership curve steepens, representing greater increases in ridership per fare unit. The ticket revenue curve is quite flat around the revenue-maximizing fare levels (i.e., at higher or lower fares in the vicinity of the revenue-maximizing fares), meaning that corresponding ticket revenue losses are minimal. This follows the same trend that has been observed in many other HST studies around the country and abroad.

EXHIBIT 6-16: REVENUE MAXIMIZING FARE ANALYSIS FOR THE INTERCITY MARKET ONLY

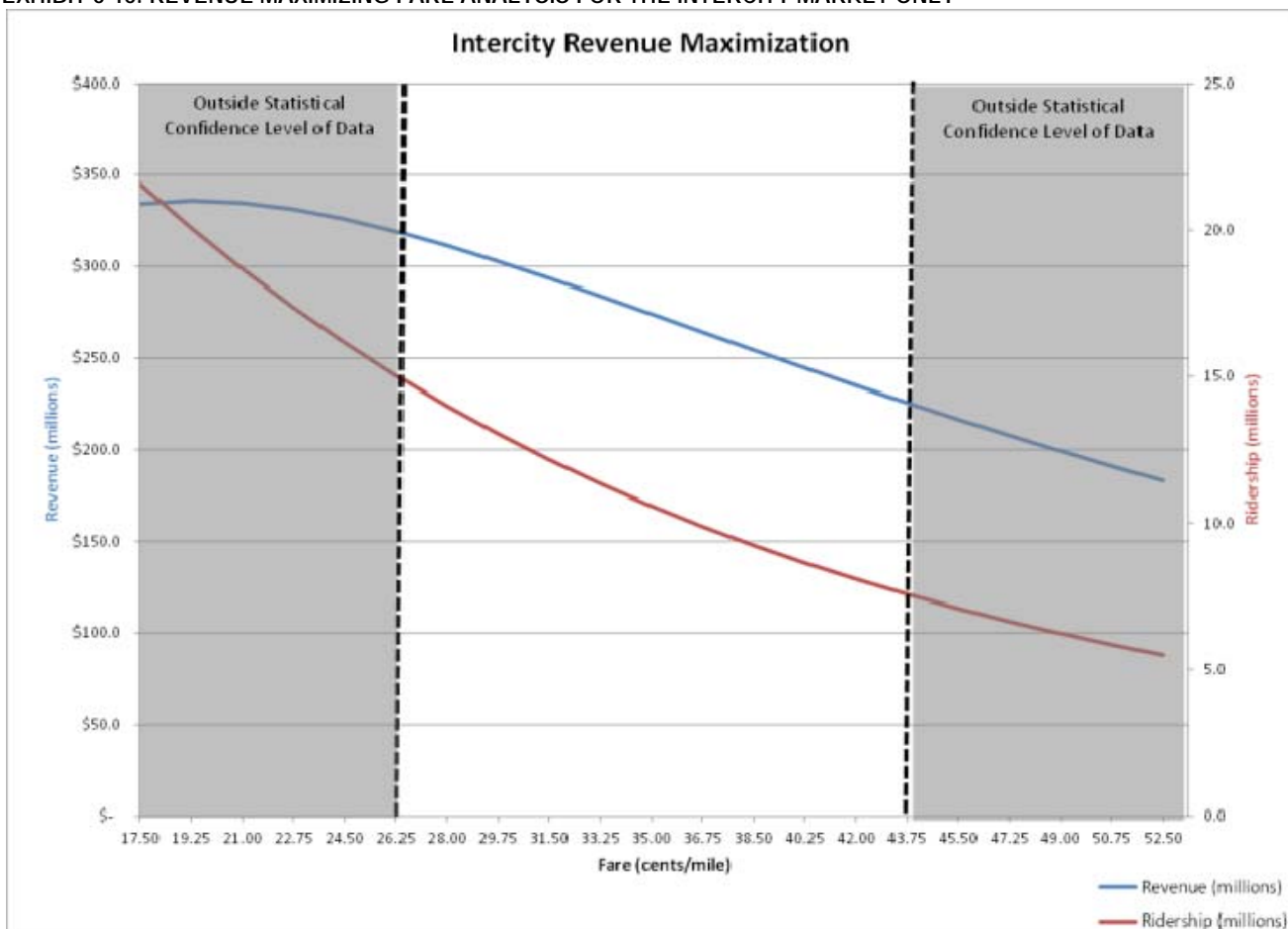

As seen in **Exhibit 6-16**, the revenue-maximizing fare level for the intercity travel market is approximately \$0.1925 per mile. However, in the Stated Preference Survey (data from which was used in estimating the parameters of the mode choice models, described in more detail in Appendix D, ICS Demand Forecast Model Documentation), respondents were asked to choose between their existing mode and the proposed train mode by making trade-offs among various level-of-service characteristics of the modes, including fare.

None of the survey questions tested respondents' behavior at fare levels lower than -25 percent (below \$0.2625/mile) or higher than +25 percent (above \$0.4375/mile) from the base fare level (\$0.35/mile) used for the survey analysis. As a result, fares above and below these levels are considered outside of the statistical confidence level of the data. Therefore, model results with fare levels outside of this range are considered unreliable. Existing fare levels for similar Amtrak services or comparable systems internationally also fall within this range. The shaded regions in **Exhibit 6-16** represent the fare levels that fall outside the accepted range.

Although \$0.1925 per mile (-45 percent of the base fare value) represents the revenue-maximizing fare level, it was not applied in the Level 3 Evaluation as it lies outside the statistical confidence level of data. Because the \$0.2625 per mile fare produces the highest revenue within the acceptable fare range, it was selected as the per-mile revenue-maximizing fare for the subsequent Level 3 Evaluation.

Exhibit 6-17 breaks down the results of the revenue-maximizing analysis at the market-pair level (previously defined) for the LPA-Base option⁵ (the scenario for which the revenue-maximizing analysis was performed). It shows that the system revenue-maximizing fare of \$0.2625 per mile may not always result in higher revenue for each market pair compared to the base fare level of \$0.35 per mile.

All the longer-distance market pairs generate higher revenue (I25N-I25S and trips to/from I70) at the revenue-maximizing fare level. For the shorter-distance market pairs (I25N-I25N, I25N-DEN, I25S-I25S and I25S-DEN), there are revenue losses at the system revenue-maximizing fare level of \$0.2625 per

mile. As all the station pair level fares are distance-based, these shorter-distance market pairs include station pairs that have lower fares in absolute terms. The ridership sensitivity to further lowering fares from \$0.35 per mile is small. The combined effects of this low ridership sensitivity and the low fares in absolute value result in no increase in ticket revenue for the shorter distance markets at lower fare levels.

EXHIBIT 6-17: LPA-BASE REVENUE-MAXIMIZING ANALYSIS AT MARKET-PAIR LEVEL

Market Pair	Ridership (millions)		Revenue (millions \$2012)	
	26.25 cents/mile	35 cents/mile	26.25 cents/mile	35 cents/mile
I70-I70	2.16	1.62	\$ 38.95	\$ 37.80
I70-I25N	0.77	0.36	\$ 28.87	\$ 16.97
I70-I25S	3.00	1.93	\$ 78.10	\$ 62.63
I70-DEN	0.57	0.35	\$ 21.64	\$ 17.40
I25N-I25N	0.99	0.82	\$ 11.35	\$ 12.58
I25N-I25S	1.78	1.06	\$ 53.68	\$ 41.02
I25N-DEN	2.28	1.90	\$ 25.05	\$ 26.68
I25S-I25S	4.40	3.69	\$ 49.97	\$ 53.07
I25S-DEN	2.45	2.01	\$ 45.17	\$ 47.84
DEN-DEN	-	-	-	-
Total	18.40	13.74	\$ 352.77	\$ 315.99

6.5.3 Environmental

Background

As discussed in Section 5, Level 2 Evaluation, the purpose of environmental analysis for the ICS was to include and document environmental considerations in developing alignments and ultimately selecting alignments that have fewer environmental constraints.

Several alignment options were eliminated during Level 2, primarily based on high environmental impacts. These included the US 6 alignment (A-1) west through Denver, the railroad alignments (NS-1 and NS-2) north and south through Denver, and the US 287 alignment (N-1) north to Fort Collins. The complete beltway concept, Scenario A-6, which included segments A-1, NS-1, and NS-2, also was eliminated, both because it included these high-impact segments and because of high costs. The eliminated alignments traversed densely developed residential neighborhoods and were thus considered "show stoppers," particularly because less impactful

⁵ Includes the total system ridership and revenue for the intercity, intra-urban, and airport choice travel markets combined.

alignments were available, and in most cases had better performance – higher speeds and ridership. (See Section 5, Level 2 Evaluation, for additional detail.)

Level 3 Evaluation Results

The Level 3 analysis included field reviews of the remaining segments to more thoroughly assess environmental impacts, refine the understanding of environmental constraints, and look for opportunities to further minimize environmental impacts through the VE process. The following narrative reflects the environmental discriminators among the LPA options. As described below the only discriminators occur with the east-to-west alignment options through the Denver metro area.

Impacts in the Denver Metro Area will Drive Future Decisions

The selection of an LPA option will ultimately be determined by the environmental consequences of constructing and operating through the Denver metro area. The objective of the Level 3 Evaluation was to assess the tradeoffs associated with each of the LPA options traveling east to west through the Denver metro area.

Providing new transportation facilities through and around the Denver metro area is challenging on any alignment. Although all of the LPA alignments (C-470, I-76, and NWQ) developed for this study generally follow established transportation corridors – highway or rail – excess ROW is generally not available within these corridors. Therefore, private property acquisition will be required from adjacent areas, most of which are developed, and some densely developed.

LPA-Base (C-470) Option

Environmental and other natural constraints are present throughout the southwest beltway C-470 alignment. The topography is varied, and both grades and curves present engineering challenges. Additionally, options to negotiate through or around interchanges and associated ramps are problematic, including costly tunnels or structures, more curves in the alignment, and/or encroaching onto adjacent properties. An overview of the horizontal alignment and its many curves is shown in **Exhibit 6-18**.

EXHIBIT 6-18: C-470 ALIGNMENT



As illustrated in **Exhibit 6-19**, properties adjacent to the west end of the alignment (shown in red) include Section 4(f)-protected park properties, including two that already extend across C-470.

EXHIBIT 6-19: POTENTIAL IMPACTS TO PARKLAND

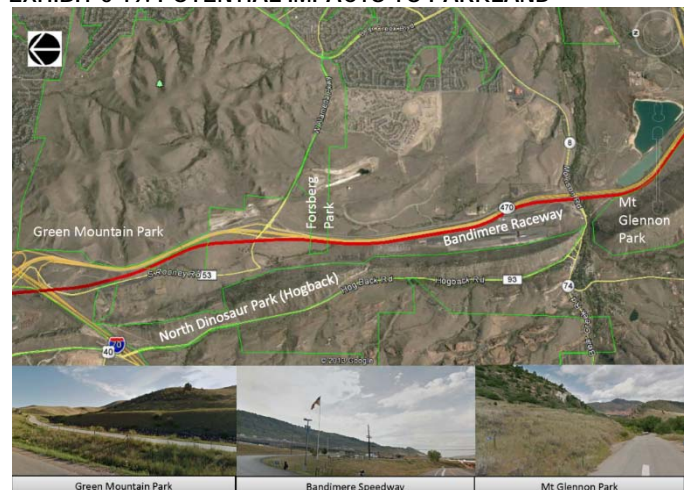

Moving south along the alignment, the southwest beltway traverses between neighborhoods on the north and Chatfield State Park and other parks on the south. South of Chatfield State Park, sizable existing residential developments are located on both sides of C-470 in the Highlands Ranch area, as illustrated in **Exhibit 6-20**.

EXHIBIT 6-20: C-470 ALIGNMENT NEAR HIGHLANDS RANCH



Although the C-470 alignment presents geographical constraints, it also offers opportunities to connect communities in the southwest area to rail options, as this portion of the metro area is underserved by FasTracks.

LPA-I-76 Option

Starting from DIA, the I-76 alignment transitions to the west just to the north of 96th Avenue. Although not as densely developed compared to other Denver metro area corridors, Commerce City views 96th Avenue as a major mixed-use corridor and does not support the I-76 alignment.

Additionally, the 96th Avenue alignment runs immediately north of and parallel to the boundary of the Rocky Mountain Arsenal National Wildlife Refuge, a Section 4(f)-protected wildlife property. The Refuge also has registered concerns with this alignment. Should the I-76 segment be selected in the future, additional work will be needed to refine or change the alignment in order for it to be supported by these stakeholders and other affected residents. As described in Section 8, Implementation Plan, the recommended Initial Operating Segment (IOS) would not include any of the east-to-west options (C-470, I-76, or NWQ) as part of the first phase, so decisions about selecting or refining any of these options can be deferred without affecting the overall HST system implementation.

West of 96th Avenue, the I-76 alignment may appear to drivers as a mostly industrial corridor; however, residential developments are interspersed throughout. These neighborhoods contain higher than average percentages of low-income and minority populations, and many mobile home parks are located near the highway. **Exhibit 6-21** illustrates a portion of the alignment (shown in turquoise) on the east end near Sheridan Boulevard. Similar situations exist from Federal Boulevard to Lowell Boulevard.

EXHIBIT 6-21: ALIGNMENT NEAR SHERIDAN BOULEVARD



West of Wadsworth Boulevard, the I-76 alignment joins with I-70. Adjacent to this stretch of highway is a frontage road system that provides access to numerous homes and businesses located along the Frontage Road. Noise walls have been constructed between the neighborhoods and I-70.

Placing HST along I-70 in this area would require reconstruction of both the frontage roads and noise walls, and acquisition of substantial ROW, including numerous relocations.

Exhibit 6-22 and **Exhibit 6-23** illustrate these conditions from Lowell Boulevard west to Ward Road.

EXHIBIT 6-22: ALIGNMENT NEAR WADSWORTH BOULEVARD



EXHIBIT 6-23: ALIGNMENT BETWEEN KIPLING STREET AND WARD ROAD



As the alignment moves west, it affects the more affluent and politically active Applewood neighborhood, which has historically been skeptical of transportation and development projects. Although no groups have raised opposition to the alignment, it is anticipated that as the project moves into the NEPA phase, public awareness of the specific alignments and impacts will increase, as will controversy.

As illustrated in **Exhibit 6-24**, this segment is very close to homes. In some cases, even without frontage road, HST implementation would require acquisition of a full row of homes.

EXHIBIT 6-24: POTENTIAL RESIDENTIAL IMPACTS

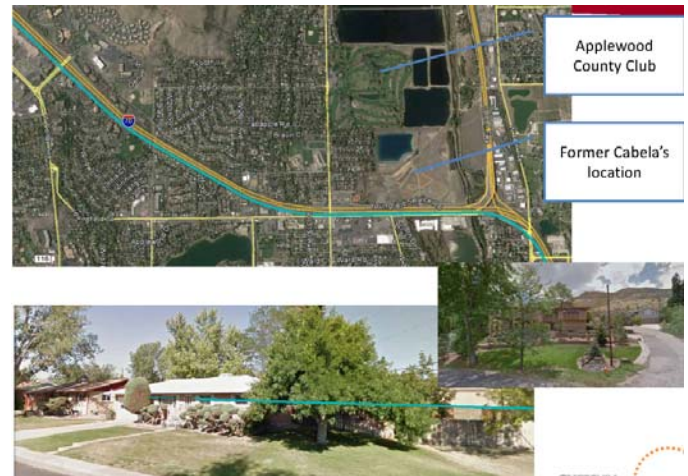

Due to the proximity of residential development along the I-76 alignment area and the likely need to relocate numerous homes and businesses, the LPA-I-76 option is likely to have greater environmental impacts and be more difficult to implement than the beltway options.

LPA-NWQ Option

In the Level 2 Evaluation, the ICS identified concerns with the NWQ design option due to historical controversy with the Jefferson Parkway (Northwest Parkway) transportation corridor. However, due to some interest from the public and elected officials in providing rail options in this area, the alignment was retained for further consideration in Level 3. As noted previously, Golden has registered concerns that the alignment conflicts with the agreed-upon cross section for the Jefferson Parkway, as well as concerns with the location of the West Suburban Station generally and how the station would be accessed from this alignment.

The NWQ alignment would follow the Northwest Parkway/proposed Jefferson Parkway corridor, which is generally characterized by limited development and substantial areas of open space. The corridor bisects or is adjacent to many large park and recreation areas, including the following (from north to south):

- Anthem Community Park
- Rock Creek Farm
- Glacier Park
- Colorado Hills Open Space
- Rocky Flats National Wildlife Refuge

- Pattridge Open Space
- North Table Mountain Park
- White Ash Mine Park
- Mount Gailbraith Park
- Windy Saddle Park
- Beverly Heights Park
- Tin Cup Hogback Park
- Apex Park Trailhead/Parking
- Thunder Valley Park

In addition, several large holdings of Boulder County open space and areas of smaller park properties are present along the alignment. The constraints of such a large number of Section 4(f)-protected properties, along with a potentially high level of neighborhood opposition in the Golden area along State Highway 93, makes this corridor challenging. However, the west alignments are unlikely to be included in a first phase of the project, and investment of additional time and engineering in this corridor could refine the alignment sufficiently to minimize impacts and achieve a socially acceptable design.

Issues Traveling North

All of the LPA options follow the same I-25 alignment north to Fort Collins, resulting in no discriminators, or preference for one option over another.

Since the Level 2 evaluation, CDOT has determined that an alignment in the median of I-25 would conflict with the North I-25 EIS recommendations for highway expansion. With highway widening planned toward the median, insufficient space would remain for HST to operate in the median. Consequently, the ICS study team re-engineered the alignment to the east side of I-25. As stated earlier, this change resulted in a substantial cost increase. However, from an environmental perspective, this segment still presents the fewest environmental concerns of any of the segments that make up the LPA options.

Issues Traveling South

Similar to traveling north, all of the LPA options follow the same I-25 alignment south to Castle Rock, Monument, Colorado Springs, and Pueblo, resulting in no discriminators, or preference for one option over another.

The Level 2 Evaluation identified a relatively high number of stream crossings (52) and miles (5) of alignment next to streams as one of the biggest impacts of the I-25 south alignment. Additionally, impacts to parks, communities, and low-income and minority populations were identified along the alignment through most of Colorado Springs and a portion of Pueblo. The Level 3 field review confirmed these impacts, identified additional impacts to parks and open space in Douglas County, and acknowledged greater concerns with the alignment coming into Colorado Springs, particularly near the proposed station at the old train station along I-25 south of Bijou Street in downtown Colorado Springs.

Based on the field review and further review of Douglas County open space maps, CDOT contacted Douglas County to obtain current GIS data for parks and open space in Douglas County. Comparing the current mapping to the refined alignment, large portions of the I-25 south alignment are within or adjacent to park or open space lands in the 30-plus miles of the alignment that is in Douglas County.

6.5.4 Engineering Feasibility

Revised Capital Costs

Exhibit 6-25 presents the Level 3 Evaluation CAPEX for the LPA-Basic, LPA-I-76, and LPA-NWQ options. All three options assume the use of single track where possible. Further, the estimates include the cost of the HST vehicles. (Note that Exhibits 6-6 and 6-7 do not include the cost of vehicles, resulting in cost differences.)

EXHIBIT 6-25: REVISED CAPEX ESTIMATES (BILLION \$)

ICS LPA Options	ICS LPA	AGS LPA	HST Vision
LPA- Base	\$16.6	\$13.5	\$30.1
LPA- I-76	\$13.4	\$16.7	\$30.1
LPA-NWQ	\$17.8	\$13.5	\$31.3

The revised estimates also include revised horizontal and vertical profiles based on DTM information. The revised cost estimates were based on the re-engineered alignment drawings prepared for the Level 3 Evaluation, using the same “parametric” estimating methodology presented in the Level 2 Evaluation. While the unit costs are the same as used for the Level 2 Evaluation, the quantities have changed considerably.

The major difference among the options is that with LPA-I-76, the I-76 segment from DIA to the West Suburban Station (near Golden) is included in the AGS estimate since it would carry the Maglev technology to the mountain communities. This effectively removes \$1.9 billion from the ICS cost and adds \$3.2 billion to the AGS cost. The reason for the difference in costs in this segment is the greater cost for the Maglev technology.

Revised Operations and Maintenance Costs

Exhibit 6-26 presents the Level 3 Evaluation OPEX in 2013 dollars for the LPA-Basic, LPA-I-76, and LPA-NWQ options. Annual OPEX for the HST Vision system is calculated to be from \$198 million to approximately \$209 million, assuming HSR for the ICS and Maglev for the AGS. An all-Maglev system is somewhat less costly at \$164 million.

Details regarding O&M cost methodology and O&M cost breakdowns are provided in a separate report, *ICS O&M Methodology*, November 2013 in Appendix C, Service Plans and OPEX Estimating Support Materials.

EXHIBIT 6-26: REVISED OPEX ESTIMATES

ICS LPA Options	ICS LPA OPEX	AGS LPA OPEX	Total HST Vision OPEX
LPA- Basic	\$144	\$63	\$207
LPA- I-76	\$120	\$78	\$198
LPA- NWQ	\$146	\$63	\$209
LPA-I-76 Maglev	\$101	\$63	\$164

While Level 2 OPEX estimates used a simple method of multiplying calculated train-miles by a single unit cost based on the RMRA Study (see *Level 2 Operating & Maintenance Cost Estimates*, May 2013), Level 3 OPEX costs were calculated using a cost allocation model. The cost allocation model assumes that each expense is “driven” by a key supply variable such as revenue hours, revenue miles, and peak vehicles. Three functional areas are addressed in the model: operations, maintenance (vehicle and ROW), and general administration. Labor and non-labor expenses are identified in each functional area. Major maintenance such as future capital costs for rebuilding HST vehicles are not included in the OPEX estimate. These costs are

carried as future capital expenses, as discussed in Section 8, Implementation Plan.

Typical development of an OPEX model involves developing productivity ratios based on actual expenses and system characteristics from established systems. However, very scant information is available due to the limited application or lack of HST technologies currently operating revenue services in the United States. Therefore, the OPEX model builds on actual costs and data available for more traditional rail systems, tailoring specific line items to account for technology differences. Information on traditional rail systems included UTA’s Frontrunner North and South Commuter Rail service, which has been able to maintain lower OPEX costs relative to other properties, as stated earlier. Information provided by Transrapid International-USA, Inc. (TRI) and American Maglev Technology, Inc. (AMT) was incorporated as applicable for Maglev technologies.

Certain elements in the OPEX model were standardized regardless of technology, such as administration staffing, train crews (one operator and one train attendant per train), station operations and maintenance, on-board and station security, and vehicle cleaning. Other elements were distinguished according to technology, such as propulsion power, vehicle maintenance, and ROW maintenance.

After establishing appropriate unit costs, the OPEX model requires the development of operating statistics that are based on service plans for each LPA option. Each of the LPA options has a distinct operating plan, as described below.

LPA-Base Option

The LPA- Base operating plan involves five basic route patterns:

- Fort Collins to Pueblo (18 round trips daily)
- DIA to West Suburban (12 round trips daily); connect with AGS service at West Suburban Station
- Pueblo to West Suburban (6 round trips daily); connect with AGS service at West Suburban Station
- Fort Collins to Golden via DIA (6 round trips daily); connect with AGS service at West Suburban Station

- AGS West Suburban to Eagle County Regional Airport (24 round trips daily)

The combined service frequencies for each corridor leads to 24 round trips daily, which translates to 6 hours of 30-minute service frequencies and 12 hours of hourly frequencies daily, for a total span of 18 hours of service daily, with some tapering of service for lighter-use days.

For the LPA- Base concept, the ICS system is considered to be HSR, whereas the AGS service from West Suburban station to Eagle County Regional Airport is evaluated as Maglev.

LPA –I-76 Option

The LPA- I-76 operating plan involves two basic route patterns:

- Fort Collins to Pueblo (24 round trips daily)
- DIA to Eagle via I-76 (24 round trips daily)

The 24 daily round trips translate to 6 hours of 30-minute service during peak times and 12 hours of hourly service, for a total span of 18 hours of service daily, with some tapering of service for lighter-use days.

For the LPA-I-76 concept, the ICS system assumes high-speed rail, whereas the AGS service assumes Maglev from DIA to ECRA.

LPA -NWQ Option

The LPA- NWQ operating plan involves the same five basic route patterns as described for the LPA- Base operating plan. However, the route to West Suburban is via the northwest quadrant of C-470 rather than the southwest quadrant, leading to different distances and travel times for those routes.

LPA-I-76 Maglev Option

This option is the same as the LPA-I-76 option except with the assumption that the ICS alignments from Fort Collins to Pueblo would operate with Maglev technology.

6.5.5 Planning Feasibility

The LPA, regardless of the option chosen, is feasible from a transportation planning standpoint. It is in conformance with the State Rail Plan and will be in conformance with the State Transit Plan now under preparation. Likewise, while not in the Regional Transportation Plans of the five member MPOs

within the ICS study area, these organizations support the LPA. As discussed below, the greatest challenge to the planning feasibility of the LPA will be the ability to gain voter support to fund it.

6.5.6 Level 3 Evaluation Benefit/Cost Analysis (BCA)

Changes from the Level 2 Evaluation were made in the following categories at the Level 3 Evaluation, based on further research and discussion.

- **Increase in Real Estate Value** –The Level 2 BCA assumed 15 to 25 acres of land and future development directly influenced by the presence of a station. Based on Denver metro area TOD studies and developments that have occurred around light rail stations within the region, the land area potentially influenced by the presence of a future station was increased to 30 to 50 acres per station for the Level 3 Evaluation BCA. The unit prices for real estate values assumed in the Level 2 Evaluation remained consistent for the Level 3 Evaluation.
- **Operations and Non-Basic Jobs** – The Level 2 BCA counted operations jobs as a project benefit. However, upon further analysis of the literature on the topic, the BCA was revised and does not include these jobs as a benefit because they can be considered part of the project cost. However, the operations jobs have a 1.5 multiplier effect throughout the economy, creating indirect and induced jobs and benefits. These spin-off jobs are counted as a benefit in the BCA.
- **50 percent Federal Funding and Multiplier Effect** – It was assumed that 50 percent of the CAPEX would come from federal government funding. Because the source of the funds is outside of the State’s economy, it would have a potentially higher multiplier than funding from local sources. The BCA does not incorporate the infusion of direct federal funds as a benefit; however, it does take credit for the indirect benefits resulting from the federal investment. While the Level 2 Evaluation BCA estimates the overall multiplier for these types of projects to be 3, in order to not overstate the potential benefits, a multiplier of 2 was used in the Level 3 Evaluation BCA.

- **50 percent Construction Jobs and Multiplier Effect** – The Level 2 Evaluation BCA took credit for the actual construction jobs created. Similar to operations jobs, these are considered a project cost. Accordingly, the Level 3 Evaluation BCA does not take credit for the construction jobs; however, the indirect jobs created as a result of the project are counted as a benefit.

Final Benefit/Cost Analysis Results

Exhibit 6-27 presents the BCA prepared for the Level 3 Evaluation. The BCA was run for the entire HST Vision, each of the LPA options, and for the proposed Initial Operating Segment (IOS) for the ICS system (Fort Collins to DIA to Briargate). The IOS is discussed in more detail in Section 8, Implementation Plan.

With an assumption of 50 percent federal funding, all B/C ratios for the LPA options are well above 1.0. The LPA-I-76 option performs the best with a B/C of 1.75, compared to the LPA-Base and LPA-NWQ options with respective values of 1.54 and 1.48. This is because the CAPEX of the I-76 segment (DIA to West Suburban Station near Golden) is included in the AGS project since it is part of the Maglev system traveling to the mountain communities. As might be expected, this results in a reduction of the BCA for the AGS project due to the increase in its capital cost.

With no federal funding, the B/C ratios for the LPA-Base, LPA-I-76, and the IOS – ICS remain above 1.0, while the B/C ratios for the HST Vision and LPA-NWQ fall below 1.0.

EXHIBIT 6-27: BENEFIT/COST ANALYSIS RESULTS FOR LEVEL 3 EVALUATION

B/C Element	Scenario	Scenario	Scenario	Scenario	Scenario IOS for ICS
	LPA-Base	LPA-I-76	LPA-NWQ	HST Vision	FC/DIA/Briargate
Costs					
CAPEX	\$16,600,000,000	\$13,400,000,000	\$17,800,000,000	\$30,100,000,000	\$ 9,810,000,000
PW Rebuild Vehicles (Year 18)	\$ 271,480,000	\$ 190,036,000	\$ 271,480,000	\$ 351,443,200	280,000,000
PW CAPEX Replacement Systems @3.3% Systems CAPEX	1,041,860,820	841,020,180	1,117,176,060	1,889,157,270	615,702,087
CAPEX Replacement Guideway @.005%	875,392,700	706,642,300	938,674,100	1,587,308,450	517,325,445
Annual OPEX	\$ 144,000,000	\$ 120,000,000	\$ 146,000,000	\$ 198,485,000	\$ 88,000,000
OPEX Cost (30 year)	\$ 2,489,760,000	\$ 2,074,800,000	\$ 2,524,340,000	\$ 3,431,805,650	\$ 1,521,520,000
Interest payments on 50% locally funded	\$ 5,965,127,000	\$ 4,815,223,000	\$ 6,396,341,000	\$ 10,816,284,500	\$ 3,525,174,450
Finance during construction @ 5%	\$ 830,000,000	\$ 670,000,000	\$ 890,000,000	\$ 1,505,000,000	\$ 490,500,000
Total Cost	\$ 28,073,620,520	\$ 22,697,721,480	\$ 29,938,011,160	\$ 49,680,999,070	\$ 16,760,221,982
Benefits					
Calculated Benefits (PW basis)					
Increase in Real Estate Value - one time deal, no PW calc.	\$6,931,267,200	\$7,746,710,400	\$6,931,267,200	\$ 10,626,244,200	\$ 4,790,728,800
Pw of Fare Box Revenue (30 year)	\$ 5,952,543,241	\$ 6,101,534,002	\$ 5,790,455,874	\$ 5,905,455,927	\$ 3,425,783,975
PW of Ancillary Revenue	\$ 178,576,297	\$ 183,046,020	\$ 173,713,676	\$ 177,163,678	\$ 102,773,519
PW of VMT	\$ 5,328,904,037	\$ 5,204,368,863	\$ 5,095,130,196	\$ 5,104,029,000	\$ 2,970,132,038
PW of VHT	\$ 734,892,967	\$ 609,857,566	\$ 686,060,284	\$ 655,097,300	\$ 431,759,465
PW of Fatality Avoided	\$ 648,984,385	\$ 633,817,779	\$ 620,514,070	\$ 621,597,817	\$ 361,719,652
Pollution benefits	\$ 1,893,664,113	\$ 1,849,409,650	\$ 1,810,590,909	\$ 1,813,753,162	\$ 1,055,457,635
PW of Non-basic jobs (1.5 multiplier)	\$ 622,440,000	\$ 518,700,000	\$ 631,085,000	\$ 857,951,413	\$ 380,380,000
Multiplier effect of Federal funding (3.0 multiplier)	\$ 16,600,000,000	\$ 13,400,000,000	\$ 17,800,000,000	\$ 30,100,000,000	\$ 9,810,000,000
Non-basic jobs (2.0 multiplier)	\$ 4,442,658,000	\$ 3,586,242,000	\$ 4,763,814,000	\$ 8,055,663,000	\$ 2,625,450,300
Total Benefits	\$ 43,333,930,240	\$ 39,833,686,280	\$ 44,302,631,210	\$ 63,916,955,497	\$ 25,851,411,894
Sum of Benefits (PW Cost Basis)	\$ 43,333,930,240	\$ 39,833,686,280	\$ 44,302,631,210	\$ 63,916,955,497	\$ 25,851,411,894
Sum of Costs (PW Cost Basis)	\$ 28,073,620,520	\$ 22,697,721,480	\$ 29,938,011,160	\$ 49,680,999,070	\$ 16,760,221,982
B/C Ratio with Federal Funding Benefit	1.54	1.75	1.48	1.29	1.54
Operating Ratio	2.39	2.94	2.29	1.72	2.25
Without Federal Funding					
Sum of Benefits (PW Cost Basis)	\$ 26,733,930,240	\$ 26,433,686,280	\$ 26,502,631,210	\$ 33,816,955,497	\$ 16,144,185,385
Sum of Costs (PW Cost Basis)	\$ 28,073,620,520	\$ 22,697,721,480	\$ 29,938,011,160	\$ 49,680,999,070	\$ 16,760,221,982
B/C Ratio w/o Federal Funding Benefit	0.95	1.16	0.89	0.68	0.96

Section 7: Public Process

7.1 Results of the Level 1 Evaluation Public Involvement Process

This section describes the approach CDOT is taking to engage stakeholders in the ICS process. This approach focuses on ways to reach out to local, regional, state, and federal agencies and presents methods for involving the general public who have an interest in HST.

Once the public involvement process is established, a description of how this process was used for the Level 1 Evaluation is presented. These findings include the feedback received from the Project Leadership Team (PLT) during two formal workshops and input from the general public during four open houses sponsored in Windsor (south of Fort Collins), Denver, Colorado Springs, and Pueblo.

7.1.1 Stakeholder Engagement

At the inception of the ICS, the study team developed a structure for communications and engagement to support sound decision making throughout the study process. A goal of the public involvement process is to consider and incorporate input from local government entities, resource/regulatory agencies, and the public. Collectively, these groups are referred to as stakeholders. Given the significant geography covered by the study, the range of stakeholders reflects the diversity of the study area.

Corridor Coordination Plan – The study team developed a Corridor Coordination Plan in June 2012 as a guide for stakeholder coordination and engagement. This plan describes the role and responsibilities of local governments, agencies, and the public in decision making, discusses a format for coordination, and establishes procedures that support timely input at key milestones throughout the study process.

Decision Structure – Stakeholder input is focused around major study milestones. Each milestone includes engagement with key stakeholders to review the study recommendations and obtain

input. This involves seeking feedback from a Project Management Team (PMT), a Project Leadership Team (PLT), and the general public. Descriptions of these three groups are provided below.

Project Management Team – The PMT includes CDOT project leadership along with representatives from federal and regional agencies and a representative from the AGS study. PMT meetings are conducted at each milestone. The PMT includes:

- CDOT Project Manager
- CDOT Transit and Rail Division Director
- CDOT Transit and Rail Staff
- Consultant Project Manager
- AGS representative
- FRA representative
- FTA representative
- FHWA representative
- RTD representative

Project Leadership Team – The PLT includes representatives from local, regional, and state governments and agencies along the Front Range from Fort Collins to Pueblo, such as:

- Representatives from study area cities and counties
- CDOT region program engineers and planners
- Transportation planning regions, represented by the Chairperson of the Statewide Transportation Advisory Committee (STAC)
- Metropolitan Planning Organization (MPO) representatives
- Railroad representatives
- Colorado Association of Transit Agencies representatives
- Transit and Rail Advisory Committee (TRAC) representatives
- RTD representatives
- Denver International Airport representatives

Public Stakeholders – Public stakeholders include the diverse range of stakeholders within the study area who could benefit and/or be impacted by HST.

As with the PMT and PLT, CDOT is engaging the public at each study milestone. The study team uses a variety of methods to engage the public in study details, including the media, a website, email information blasts, and public open houses.

7.2 PMT and PLT Engagement

This section focuses on how PMT and PLT input was received and incorporated during the Level 1 Evaluation. The process began with an internal team chartering meeting, followed by two PLT workshops, and concluded with four public open houses to introduce the ICS and obtain input for evaluation.

7.2.1 Internal Team Chartering

In May 2012, members of the PMTs from the ICS and AGS studies met at CDOT Headquarters to charter the study team and confirm the overall vision for the ICS. In addition to PMT members, CDOT's Transit and Rail Director, the Project Manager, the consultant Project Manager, and staff from FRA, FTA, FHWA, and RTD attended. CDOT staff and the consultant team were in attendance to kick off the study, charter the team, discuss the scope, and confirm the vision.

Attendees of the team chartering brainstormed multiple study goals, critical success factors, risks, and mitigations. A few of the key themes identified include the need to:

- Maintain a holistic view of the study (this impacts the entire Front Range and I-70 mountain corridor)
- Maintain clear and ongoing communication with stakeholders
- Develop transparency in the ridership modeling process
- Achieve effective coordination and decision making between the ICS and AGS studies
- Identify implementable projects that generate stakeholder support
- Develop credible, transparent, and defensible conclusions
- Work cooperatively with existing transit systems to develop ridership and success for all

7.2.2 PLT Workshop – June 2012

The first PLT workshop was conducted at CDOT Headquarters in June 2012. The study team

introduced the study scope, background, and methods for engagement for the PLT and other stakeholders. A presentation was given on the study vision, a proposed project purpose statement, potential HST segments and scenarios, and criteria for the Level 1 evaluation. The PLT members discussed their thoughts regarding the Purpose and Need, criteria, and segments that were presented by the study team. Written feedback was also provided following the meeting. Examples of a few of the key themes identified include:

- Concerns related to how the selection of train technology will impact the AGS corridor
- Desire that land use be a key consideration for location of the HST stations
- Questions regarding the potential fares and whether they will cover operating costs
- Desire for criteria to support local communities and regional land use, sustainability, and mobility goals
- Ensure that the planned system adheres to FRA requirements for HST
- Maintain the study's focus at a regional level
- Maintain compatibility with existing environmental planning documents such as the North I-25 EIS, etc.
- Acknowledge that stations cannot and probably should not be located in every city, otherwise this is not HST
- Consider survey research, focus groups, or other adequate methods to address public misperceptions about the costs and advantages of mobility modes
- Develop early understanding and ongoing support among key political leaders, interest groups, and media
- Ensure present and future freight rail capacity is maintained
- Promote an integrated Colorado transportation network
- Ensure station locations and corridors complement present and future street, road, and highway networks
- Consider affordability in the initial evaluation as it relates to the demand for other critical services/projects in the state

The Vision Plan of the Pikes Peak Area Council of Governments (PPACG) supports an inter-regional passenger commuter rail alignment along the existing rail line alongside I-25, linking the downtowns of Monument, Colorado Springs, and Fountain.

Based on the feedback received, the study team refined the segments and began to evaluate each using criteria developed for the Level 1 Evaluation.

7.2.3 PLT Workshop – July 2012

The second PLT workshop was held in July 2012 at CDOT Headquarters. The PLT reviewed the progress made since the previous workshop, modifications to the Purpose and Need, details of the scheduled public open houses, and the Level 1 Evaluation results. Again, the opportunity for follow-up written feedback was provided.

At this workshop, the revised Purpose and Need statement generated a fair amount of discussion. While the ICS is not a National Environmental Policy Act (NEPA) study, a Purpose and Need has been requested to ensure consistency should the project be advanced to NEPA in the future. Key discussion themes surrounding the Purpose and Need statement included:

- Ensure the statement is broad enough to cover interregional commuters, business, and tourism travel
- Consider both existing and future mobility demands
- Consider multiple modal options
- Consider land use
- Focus the Purpose and Need toward HST
- Ensure the Purpose and Need is closely aligned with NEPA

The PLT also reviewed the current segments and the initial evaluation results to be presented to public stakeholders at future Level 1 Evaluation open houses. Key themes of these comments include:

- Identify how options are integrated with the RTD system
- Clarify whether ridership is considered at the Level 1 Evaluation stage
- Ridership to DIA will potentially be stronger than to Denver Union Station (DUS).

- Define how economic benefit is considered for each of the scenarios.
- Focus on FRA standards for HST.
- Support exists for the RMRA station locations
- Locating a station at the National Western Complex would likely not be feasible or generate ridership
- Stopping HST on the perimeter of the Denver metropolitan area and relying on RTD service to make final connections may negatively impact ridership
- Focus on formal population and employment statistics as published by the MPOs
- Clarify for the public that this network is high speed and not a commuter operation with multiple stops
- Outline the next major steps for the public during the open houses

The comments received from the PLT have been considered and were incorporated into the Level 1 Evaluation.

7.3 Public Stakeholder Engagement

Integral to the study process is input from the public at each milestone, as illustrated in **Exhibit 7-1**. This input was obtained through a series of open houses with a variety of techniques used to inform participants about the study and to document their thoughts regarding the study vision, a proposed Purpose and Need statement, potential HST segments and scenarios, and criteria for Level 1 Evaluation.

EXHIBIT 7-1: PUBLIC PROCESS



7.3.1 Public Open Houses

The first series of public open houses were conducted at four sites along the Front Range. Members of the public and the media were invited to learn more about the study and provide input to guide the study team's work. Multiple CDOT databases from past projects, including the CDOT *State Rail Plan*, *RMRA High-Speed Rail Feasibility Study*, and *I-70 Mountain Corridor PEIS*, were used to notify stakeholders of the open houses. Formal press releases were sent to multiple media outlets two weeks prior to the open houses. Media outlets across the Front Range included notices and articles in local newspapers, radio, and television news broadcasts as a result of the press release. Notifications were also sent to major business organizations (Chambers of Commerce) throughout the Front Range to encourage additional stakeholders to attend. Finally, the PLT members were requested to distribute open house announcements to their constituents.

Each open house presented the same information and utilized the same graphic materials. A 30-minute overview presentation provided information on the study background, segments considered, and Level 1 Evaluation. The open houses were conducted from 4:00 pm to 7:00 pm, with the 30-minute overview presentation at 4:30 pm and repeated at 6:00 pm. Accommodations for persons with physical limitations and Spanish-speaking stakeholders were offered at each open house. The open house dates and locations are noted below.

Colorado Springs Area

July 16, 2012

Pikes Peak Area Council of Governments
15 South Seventh Street, Colorado Springs, CO

Pueblo Area

July 17, 2012

Pueblo Convention Center
320 Central Main Street, Pueblo, CO

Fort Collins Area

July 18, 2012

Windsor Recreation Center
250 North 11th Street, Windsor, CO

Denver Metropolitan Area

July 19, 2012

CDOT Region 1 Offices – Trail Ridge Room
425 C Corporate Circle, Golden, CO

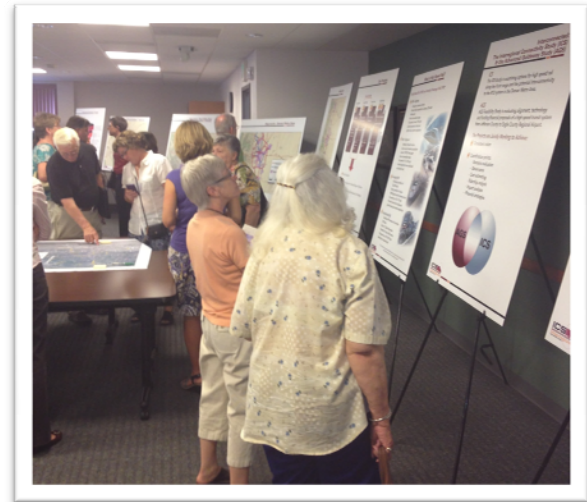

Each open house included a series of presentation boards providing a study overview, details of the segments and scenarios, the study process, the Level 1 Evaluation results, and the study schedule. Detailed aerial maps of the study area were provided to aid discussion with stakeholders and allow stakeholders to write comments directly on the maps. Computer projections of the segment being considered were shown in Google Earth format to aid discussion.

The open houses were well attended and garnered media coverage in local newspapers, radio, and television news outlets. A total of approximately 240 stakeholders attended the four open houses.



Comments were collected through a variety of methods. A comment area was provided at each open house. A hard copy comment form was available, as well as laptop computers for people to

type comments directly into the comment database. Study team staff were available throughout the open houses to have one-on-one conversations with stakeholders. Mail in and online website comments were also accepted following the open houses.

Key stakeholder comments by geographic area are highlighted below:

- **Colorado Springs Area** – Many attendees were opposed to the greenfield segment as it crosses through the Black Forest area. They expressed a preference for a segment that follows I-25 or parallels the existing rail corridor and provides service to downtown Colorado Springs. Alternatively, a segment east of the Black Forest was also suggested. Additional noted concerns included noise, forest fires, property impacts, cost, and the appropriateness of HST versus commuter rail for the Front Range. Attendees suggested several additional criteria, including a cost/benefit comparison of implementing HST.
- **Pueblo Area** – Some attendees were in favor of a HST connection along the Front Range extending south to Pueblo and linking to the Pueblo Union Depot. Of those in favor, one concern expressed was the lack of reliable public transit connections to medical services in Denver, especially for the disabled. Others expressed concern over the lack of demand and population density between Colorado cities to support HST. There were noted reservations regarding Colorado’s financial state, the current economic downturn, and the cost to construct and operate HST.
- **Fort Collins Area** – Attendees were well informed of the I-25 North EIS process and the potential transit improvements related to that study. They expressed a mix of support and concern for HST service. Attendees noted support for extending service to Fort Collins’s downtown Transit Center regardless of the segment selected. Attendees expressed interest in utilizing the existing BNSF railroad segment between Longmont and Fort Collins and avoiding the I-25 segment as the latter misses the major population centers. Concerns regarding the cost to construct and maintain a HST system were voiced.
- **Denver Area** – Attendees did not indicate any preference for segments through the Denver

metropolitan area over segments on the periphery as a route to DIA. Several comments were made that serving the urban population centers is critical and that HST is essential to tourist travel and the state and local economies. Some attendees noted that DIA may be the key destination, not central Denver or DUS.



- A comment form was provided at the workshops to focus stakeholder comments on key questions relevant for this stage of the study. The form also allowed stakeholders to add their general comments on the study. The questions on the form are included below, along with a brief summary of responses received for each question.
- **What do you see as the benefits of High Speed Rail in Colorado?** Many of the responses indicated benefits such as providing connectivity, connecting four major cities along the Front Range, and providing transportation options other than driving, thus bringing Colorado into the 21st Century. Some responses noted that there are no benefits to HST, there is not enough population in Colorado, and that the concept is not a wise expenditure of tax-payer money.
- **Do you have additional evaluation criteria that should be considered? If yes, what are they?** Over 85 percent of the respondents answered “yes” and suggested additional criteria, including costs (cost/benefits, cost effectiveness), property impacts, and the ability to provide connectivity within the cities. The study team incorporated these criteria into the increasingly detailed Level 2 and Level 3 Evaluations.

- **Do we have a reasonable range of segments? If not, what additional segments should be considered?** Just over 60 percent of respondents felt that additional segments should be considered. Respondents suggested new segments east of the Colorado Springs area (outside of Black Forest), along I-25 both north and south of the Denver metropolitan area, along the existing railroad corridors, and to city centers or downtowns.
- **Do you have any other comments or concerns about this study?** Responses to this question varied widely. Generally, some were supportive while others were skeptical about the ability of CDOT to provide a workable, cost-effective HST solution for the Front Range.
- The formal comment period for the Level 1 Evaluation closed on August 13, 2012. General study comments can still be made at the study's website at: <http://www.coloradodot.info/projects/ICS>. Study background details and the materials presented at the public open houses are also available on the website.

The comments received from the public stakeholders were considered and incorporated into the study as appropriate.



7.4 Level 2 Evaluation Public Involvement Process

The public process for Level 2 Evaluation was carried forward from the Level 1 Evaluation. As described below, it included four PLT meetings and five public workshops.

7.4.1 Project Leadership Team Engagement

This section focuses on the continued dialogue with PLT through Level 2 and their input toward the Level 2 Evaluation. The study process continued on from the Level 1 Evaluation with a PLT workshop and 3 PLT meetings, and concluded with four public open houses to obtain public input for further evaluation.

7.4.2 PLT Workshop 3 – December 10, 2012

The first PLT workshop was conducted at the Jefferson County Administration Building in December 2012. The study team discussed the project update, results from Level 1 Evaluation, Level 2 evaluation criteria, ridership modeling, benefit/cost studies, an update on the AGS Study, and had break-out sessions to discuss alignment alternatives. The break-out sessions were held for the PLT members in the North Metro Area, east-west through metro Denver, north-south through metro Denver, Colorado Springs/Pueblo, and Northern/Fort Collins. During the break-out sessions, the PLT members discussed their thoughts regarding the Level 2 evaluation and criteria, and alignments that were presented by the study team. Written feedback was also provided following the meeting. Examples of a few of the key themes identified are provided below.

North Metro Area Key Comments

- Commerce City opposes anything along 96th Avenue because of platted and soon-to-be developed land.
- Thornton opposes the use of I-25 between the RTD ROW crossing (north of Erie exit, south of Hwy 52) and E-470. Maintain this area for auto-oriented development.
- A station at Pecos would provide connections between North West Rail, ICS and Gold Line.

East-West Through Denver Metro Area Key Comments

- I-70 mountain corridor representatives do not support an alignment that shares track with the Gold Line as it is not technology agnostic.
- Does not make sense to model Golden to DUS to DIA because it is a duplication of RTD service and does not leverage those investments.

North-South Through Denver Metro Area Key Comments

- Denver and RTD support having the passenger rail service go through downtown Denver and into the DUS.

Colorado Springs to Pueblo Key Comments:

- Castle Rock would prefer a station, not in downtown due to impacts, but further north between US 85 and I-25 near the new interchange slated to be built in 2013.
- Pueblo generally agrees with the ICS proposal to enter downtown from the northwest and affirms that CDOT should not be coming in along the railroad alignment from the northeast.



Northern/Fort Collins Key Comments

- Longmont would prefer that the alignment serve downtown Longmont
- The North I-25 EIS identifies the 287 corridor as commuter rail with stations in each community. There is strong community support for alignment, as commuter rail.

Based on the feedback received, the study team refined the segments and began to evaluate each using criteria developed for the Level 2 Evaluation.

7.4.3 PLT Meeting 4 – February 26, 2013

The fourth PLT meeting was held in February 2013 at CDOT Headquarters. The PLT reviewed the progress made since the previous December workshop, discussed input received at the December workshop in more detail, and conducted a group revenue exercise. The group was also informed of the AGS Study progress. Key themes of the comments received include:

- Standards for grade separation and grade crossing protections should be a strong consideration through the Denver Metro area and would likely slow speeds significantly. (Note: the HST system would have no at-grade crossings)
- Interest in the importance of a direct connection to DIA over Downtown Denver or even the Denver Tech Center. Broad origin/destination information and trip shares should be considered.
- Interest in more detail at Level 3 including cut/cover tunnel costs vs. bored tunnel costs, engineering modifications and value engineering and phasing.
- Remember to consider community impacts; elevation through Castle Rock or other communities would have big impacts, explore COS airport connections and implications.
- With regard to funding sources, the group voiced interest in oil and gas severance taxes, including the coal portion, lift ticket taxes or other visitor fees.
- Tax Increment Financing (TIF) is interesting politically
 - Suggest future slide or discussion on sharing of TIF funding with local governments.
 - Sliding scale of revenue sharing: maybe in the early years 100 percent of funds go to pay off bonds/debt for HST system. Later years transition to something like 20 percent for HST O&M costs, and 80 percent for local use on local projects.
- Most stations will be new stations, so Public-Private Partnerships (P3) should be explored to create them. May be separate from the rail/guideway infrastructure to be the most successful.
- VMT tax or mileage-based user fee (MUBF), if implemented, would likely mean the removal of the gas tax as we know it. VMT/MUBF would be a more efficient overall solution if the privacy issues and logistical complexities of implementing it could be addressed.
- HST will add to sprawl so development fees are important. Development around future stations should generate development fee revenues, TIF or other funding sources.

- Sources of funding should reflect the areas that receive service.
- Each segment needs to pay its way – geographic equity is important.
- If the effect on DIA is to reduce parking demand, then dollars that would have been used by airport to fund parking structures/service should be applied to HST.

The comments received from the PLT were considered and incorporated into the Level 2 Evaluation and revenue and funding considerations.

7.4.4 PLT Meeting 5 – April 17, 2013

The fifth PLT meeting was held in April 2013 at CDOT Headquarters. The PLT discussed Level 2 operating expense (OPEX) estimates, preliminary ridership results, Level 2 results-scenario evaluations, and Level 2 early benefit/cost (B/C) results. Key themes of the meeting included the following discussion points and comments:

- PLT member voiced interest and concern over the source data for the modeling effort as a key element of buying into the results. Source data included existing local data, CDOT Traffic count data, new data developed for this effort and anonymous cell phone location data from Sprint. Data was processed for three segments of time: February, July and October and for weekend and weekday and for traveler type: resident, visitor, and through traveler. A Stated Preference Survey (SPS) was conducted in 2012, and AGS was selected as choice for time savings (30 percent), environmental or congestion reasons.
- PLT members were concerned that often SPS tend to not provide accurate results. The team worked with a specialty firm that designs these, made efforts to avoid leading questions, tried not to paint unnecessarily negative views. We did what we could to minimize those effects.
- How was RTD system demand and ridership integrated? Intra-urban model predicted connectivity between RTD routing and HST routes. Possibility of completion of routes between systems, and also feeding the system.
- There would be an interface potential at Pecos Street station with Northwest and Gold Line. These are going to be major decision points, and it is important to show connecting points and pros/cons of the connecting points with the RTD system.

pros/cons of the connecting points with the RTD system.

- Connecting with the north-south segment is also critical – connecting Fort Collins to Summit County and Vail will require a super intermodal center that accommodates north-to-south and east-to-west connectivity.
- Shared track option produces a reduction in cost just in the metro area. To get to the mountains, HST would be using steel wheel, which cannot get to as many destinations and would likely have lower ridership.

7.4.5 PLT Meeting 6 – May 1, 2013

The sixth PLT meeting was held in May, 2013 and the PLT reviewed the scenarios presented at the April PLT, along with additional scenarios that travel around the Denver metro area, rather than through it. PLT member comments about scenario preferences were captured in the break-out session:

- Going through the center of Denver would have significant environmental, construction and social impacts and may delay progress of an HST line altogether.
- Service through the Denver metro area and to DUS directly is not compatible with the density in the area.
- Scenarios B-2A and B-5 provide the best options for avoiding Denver impacts and successfully implement HST. In fact, the majority of the PLT members stated that it is likely that the options traveling through the Denver metro area would not survive the NEPA environmental review process, or that the approvals would so dramatically delay a proposed HST project that it would kill any momentum for implementation.
- Marrying up with RTD's Denver service makes sense.
- When considering an alignment around Denver (B-2A or B-5) a 10-15 minute travel time difference to the mountains may not be unacceptable.
- The mountain corridor stakeholders would prefer the fastest, most direct service between DIA and the mountains and would like to see Maglev modeled for all scenarios.

- Direct service from the south to DIA would be preferred; direct service from Fort Collins to DIA would also be preferred.
- The need to address access to the Central Business District in Denver is still a critical element of an overall system according to some PLT members.
- An optional Denver-based scenario would include traveling east-west on I-76 and modifying Scenario A-5A to go to Pecos Street Station rather than DUS, serving Northwest Rail and the Gold Line with a quicker transfer.
- DIA is a major state investment and connections between this facility and the rest of the state are important; airport officials strongly support more modal options to DIA.
- In general the PLT was more supportive of the scenarios that travel around the Denver metro area (Scenarios B-2A and B-5) than those that travel through it (Scenarios A-1A, A-1B, A-5A and A-5B). A key concern of the PLT, however, continues to be the need to move riders into downtown Denver in addition to DIA. All comments were incorporated into the Level 2 Evaluation.

7.5 Public Engagement

Integral to the study process is input from the public at each milestone, as illustrated in **Exhibit 7-2**. This input was obtained through a series of open houses with a variety of techniques used to inform and update participants about the study and to document their thoughts regarding the potential HST segments and scenarios, and criteria for the Level 2 Evaluation.

EXHIBIT 7-2: MILESTONE WORKSHOP PROCESS



7.5.1 Public Open Houses – May/June 2013

Members of the public and the media were invited to attend the second series of public open houses to learn more about the ICS, as well as the AGS and provide input to guide the team's findings on the Level 2 Evaluation.

As with the Level 1 public workshops, multiple CDOT databases from past projects, including the CDOT *State Rail Plan*, the RMRA *High-Speed Rail Feasibility Study*, and the I-70 Mountain Corridor PEIS, were used to notify the public of the Level 2 Evaluation of the open houses. Formal press releases were sent to multiple media outlets prior to the open houses. Media outlets across the Front Range included notices and articles in local newspapers, radio, and television news broadcasts as a result of the press release. Notifications were also sent to major business organizations (Chambers of Commerce) throughout the Front Range to encourage additional stakeholders to attend. Finally, the PLT members were requested to distribute open house announcements to their constituents.

Each of the scheduled open houses presented the same core content, with some specific issue-focused information targeted for the specific location.

All open houses were scheduled from 5 p.m. to 7:30 p.m. with a 30 minute informational presentation provided at 6 p.m. The schedule of meetings hosted is below:

- Colorado Springs Area
 - May 29th, 2013 from 5 p.m. to 7:30 p.m.
 - Pikes Peak Area Council of Governments – 15 South Seventh Street, Colorado Springs
- Pueblo Area
 - May 30th, 2013 from 5 p.m. to 7:30 p.m.
 - Pueblo Convention Center – 310 Central Main St., Pueblo
- Fort Collins Area
 - May 5th, 2013 from 5 p.m. to 7:30 p.m.
 - Windsor Recreation Center - 250 North 11th Street, Windsor
- Denver Metropolitan Area
 - June 6th, 2013 from 5 p.m. to 7:30 p.m.
 - CDOT Headquarters Auditorium 4201 E Arkansas Ave, Denver

- Mountain Corridor (ICS/AGS)
 - June 11th, 2013 from 5 p.m. to 7:30 p.m.
 - Silverthorne Library 651 Center Circle, Silverthorne

Each open house included a series of presentation boards providing a study overview, details of the segments and scenarios, the study process, the Level 1 Evaluation results, and the study schedule. Computer projections of the segments being considered were shown in Google Earth format to aid discussion. The open houses were well attended and garnered media coverage in local newspapers, radio, and television news outlets.

Comments were collected through a variety of methods. A comment area was provided at each open house. A hard copy comment form was available, as well as laptop computers for people to type comments directly into the comment database. Study team staff was available throughout the open houses to have one-on-one conversations with stakeholders. Mail-in and online website comments were also accepted following the open houses. Key stakeholder comments by geographic area are highlighted below:

- **Colorado Springs** – Public meeting participants were pleased with the dismissal of the alignment through the Black Forest. There was interest in the alignment that provided service to both DIA and the mountain corridor, although there appeared to be a preference for getting to downtown Denver over getting to DIA on a regular basis. One key concern was that the implementation of any of the scenarios would require new taxes for funding. New taxes were not supported by most of the group.
- **Pueblo** – No real preference was stated by the group, but there was recognition that the scenarios around the Denver metro area provide access to DIA without the delays of going through the Denver metro area.
- **Fort Collins** – Stakeholders in this portion of the study area were most concerned that the commuter rail option on SH 287 be retained if HST is built in the I-25 ROW. They preferred alignments that linked the northern cities with DIA and Colorado Springs but also provided a direct link to the mountain corridor.
- **Mountains** – The mountain corridor stakeholders expressed support for alignments that provide a direct link from their communities to DIA. One –seat ride and direct, convenient service between DIA and the mountain communities is preferred, with or without direct service through Downtown Denver.

7.5.2 Written Feedback

A comment form was provided at the workshops to focus stakeholder comments on key questions relevant for this stage of the study. The form also allowed stakeholders to add their general comments on the study. The questions on the form are included below, along with a brief summary of responses received for each question. In total, 33 responses were collected.

- Based on the information presented at the open house, please choose the three high speed rail or advanced guideway scenarios you feel would best address the state's needs:
 - What do you see as your first choice scenario for the alignments? Approximately 27 percent of the respondents chose Scenario B-2A, 15 percent of the respondents chose Scenario A-1A (I-76), 12 percent chose Scenario A-1B (US 6), and another 12 percent chose Scenario B-5.
 - What do you see as your second choice scenario for the alignments? Approximately 27 percent of the respondents chose Scenario A-1B (US 6), 15 percent chose Scenario B-5, and 12 percent chose Scenario A-1A (I-76).
 - What do you see as your third choice scenario for the alignments? Approximately 24 percent of the respondents chose Scenario C-1, 12 percent chose Scenario B-2A, and 12 percent chose Scenario A-5.
- Do you have comments on the Northern alignments between Denver and Fort Collins? Responses to this question varied widely. Generally, most were supportive of the I-25 alignment while others were skeptical about connectivity to communities and the need for HST.
- Do you have comments on the Southern alignments between Denver through Colorado Springs to Pueblo? Responses to this question varied widely. Generally, most were supportive of the new I-25 alignment, away from the Black

Forest while others were skeptical about connectivity to communities and the need for HST.

- Do you have any additional comments?
Responses to this question varied widely. Generally, many were supportive of HST while others were skeptical about the ability of CDOT to provide a workable, cost-effective HST solution for the Front Range.

The comments received from the public stakeholders were considered and incorporated into the Level 2 Evaluation.

7.6 Level 3 Evaluation Public Involvement Process

The Level 3 Evaluation Process carried forward the public involvement process performed in Level 1 and Level 2. Dialogue continued with the PLT at four PLT meetings and the findings and recommendations for Level 3 were shared and discussed with the public at four public open houses.

7.6.1 Project Leadership Team Engagement

The PLT played an important role in the refinement of the alternatives and phasing of future operating segments in Level 3. Their input helped guide the project team toward accepted outcomes reflective of regional interests.

7.6.2 PLT Meeting 7 – August 13, 2013

The seventh PLT meeting was held in August at CDOT Headquarters and included a review of the project's Critical Success Factors, project progress and the intent and definition of the Level 3 Evaluation. The PLT also reviewed the Level 3 scenarios, value engineering efforts and an initial range of minimum operating segments. Key themes of comments related to the presentation and materials included the following:

- Interest in retaining options that bring service directly into DUS and Downtown Denver and not only east of downtown to DIA, access to Denver being an important piece of the picture
- Questions over the state of Maglev technology and a desire to stay open to technology options as they mature, and not limit the study to steel wheel alternatives

- Interest in phasing first operational segments in a way that builds political support and ensures that all areas get something tangible out of the process.
- Interest in improved interoperability of the system so that passenger transfers between HST and the RTD system are minimal.
- Interest in initial potential MOSs that reflect the strongest ridership – such as alignments south that include connections to DIA and still address the need to serve downtown Denver – presenting equitable opportunities for service for all areas.

The comments received from the PLT were considered heavily in the assessment of IOS options.

7.6.3 PLT Meeting 8 – September 17, 2013

The eighth PLT meeting was held in September at CDOT Headquarters and examined the revised phasing and potential financing of the minimum operating segment options. The PLT voiced the following interests and concerns:

- Concern that a sales tax may not be attractive to voters or may be delayed with the passing of MPACT 64, and optional revenue sources should be considered.
- Desire to keep the use of the I-25 north median for HST as a possibility for now as it lowers the cost of running an MOS north to Fort Collins.
- Interest in an IOS that connects to Pueblo; Pueblo will want service or an explanation of how that part of the state will be served.
- Interest in looking at ICS and AGS as a whole system with a systematic approach; ensure that a fully built-out system for AGS means DIA to Eagle County Regional Airport.
- Need to keep the full system on the table as not every area will be part of the IOS, and understanding the HST Vision will be critical to gaining support for the long-term system.
- Interest in hearing response from the public on the potential scenarios and phasing.

The PLT input was important to refining the initial operating scenarios and phasing recommendations for presentation to the public.

7.6.4 PLT Meeting 9 – October 15, 2013

The ninth PLT was held in October at the CDOT Headquarters and included a review of the ridership elasticity study results, the value engineering results for the full build scenarios, revised benefit/cost results and a discussion of the minimum operating segments including segments to the north, south, and DIA. The PLT comments and discussion followed these common themes:

- Interest in the value engineering results, single track configuration in some locations, and ability to operate the system and retain schedule.
- Interest in the relationship between reducing costs and related train performance and ridership numbers, especially with regard to the effect of transferring between the ICS and AGS systems.
- Discussion regarding the cost effectiveness of an MOS to the north that would require use of the CDOT ROW and likely include managed lanes versus an MOS to the south where stronger ridership exists and no other improvements are currently anticipated.
- Interest in continuing to accommodate all technologies at this phase of study.
- Concern over the elimination of direct service to DUS and service instead around the perimeter to DIA only.
- Recommendations that the MOS must be successful, not just cost effective, that we need a vision and great political will, and we need to begin to understand that we must pay for our future transportation system.
- Recommendations that the MOS include DIA and provide the best equitable distribution of service to garner broadest support.
- Interest and debate over the MOS approach – a more cost-effective segment-by-segment approach versus a “go big or go home” longer MOS that includes service to more people and garners stronger political support.
- Interest in the mountain corridor as an initial segment because of the political organization in the corridor and the visionary operation it brings to relieve congested conditions.

The PLT input was weighed heavily in study recommendations and final materials for the public meetings.

7.6.5 PLT Meeting 10 – December 18, 2013

The final PLT meeting was held in December at the CDOT HQ Auditorium. The PLT reviewed the key comments from PLT Meeting 9 and the public input received at the November and December round of public open houses. The PLT received updated cost and performance metrics and reviewed key engineering, financial, and environmental conclusions of the study. Finally, the PLT reviewed the Next Steps for future implementation of ICS and AGS systems.

Over 200 people attended the four public meetings held in Windsor, Denver, Colorado Springs, and Pueblo. Generally, support was high for the ICS HST Vision, and attendees agreed with the recommended phasing of the MOS, with the exception that Pueblo would like to be included in the initial phase. PLT members were pleased with the overall public input and level of support.

Key themes of PLT comments at PLT Meeting 10 included:

- Implementing the Front Range first, before the mountain corridor, makes sense and ensures stronger ridership for the system. However, CDOT needs to address the traffic congestion in the mountain corridor and the politics of maintaining their support. Is it possible to serve a portion of the corridor to Silverthorne or Dillon in order to address the public need?
- There is a rapidly increasing recreational user group in the I-70 mountain corridor, and by not including this corridor in the IOS, CDOT is not addressing that growing demand and related transportation issue.
- Some believe that riders would pay a higher cost-per-mile ticket price for service to the mountain corridor than they would for service in the Front Range.
- The FasTracks vote committed local governments to a local contribution to the system. It would be helpful to certain PLT members to understand the anticipated local contribution for ICS and the economics of how local governments might pay for stations when

potential tax increment funds would likely already be committed to the development surrounding the station.

- Maglev and steel wheel technologies are both part of the HST Vision and would ideally be looked at together or remain on the table as technology options.
- To succeed, CDOT needs to address the full system needs. The IOS should show Phase 1 with bus transportation to locations where rail is to be implemented in later phases.
- Local transit system connections will be particularly important to communities with a station.
- Lobbying of the HST Vision will be important, and a “road show” for local governments, communities, and legislators would be a telling way to share information and gather feedback on the issue throughout the state. The Mayor’s Caucus and Metro Economic Development Coalition would be good first stops for such a road show.

7.6.6 Public Open Houses – November 2013

The public and media were invited to attend the final series of public open houses to review the results of the Level 3 Evaluation and study recommendations.

Formal press releases were sent to multiple media outlets prior to the open houses, and notices and articles in local newspapers, as well as radio and television news broadcasts resulted. Notifications were sent to major stakeholders and PLT members for further distribution. The open houses were held as follows:

- Windsor/Fort Collins Area
 - November 4, 2013 from 5:00 pm to 7:00 pm
 - Windsor Library, 730 3rd Street Windsor, CO
- Denver Metropolitan Area
 - November 19, 2013 from 5:00-7:00 pm
 - CDOT Golden Office, 425C Corporate Circle, Golden CO
- Colorado Springs Area
 - November 20, 2013 from 5:00-7:00 pm

- Pikes Peak Council of Governments (PPACG), 15 South Seventh Street, Colorado Springs

- Pueblo Area

- November 21, 2013 from 5:00-7:00 pm
- Pueblo Convention Center – Heroes Pavilion, 320 Central Main Street, Pueblo

Each open house included a short updated series of presentation boards illustrating the LPA and potential MOS. The project team gave an extended presentation highlighting the project purpose, outcome of the Level 2 Evaluation and Level 3 recommendations for the LPA, efforts to improve the



performance of the LPA, and the recommended phasing and possible financing of the IOS and MOS. The team also reviewed the cost/benefit analysis for the HST system and likely next steps for ICS.

The open houses were well attended by the public, stakeholders, and elected officials, and support for the ICS Vision was strong. The team held lengthy discussions with the public during the course of the presentation and developed a good sense of the level of interest or support by the public. Verbal, paper, and website comments were collected. Key comments and statements by geographic area from each open house included the key themes described below.

Windsor/Fort Collins Area

Public meeting participants were supportive of the HST Vision program for the state and recognized it as a great way to address future congestion and move people along the Front Range. There was a continued interest in ensuring that commuter rail and HST can both exist in the northern area, and concerns that HST does not offer the additional stops, frequency and flexibility of commuter rail desired along the 287 corridor. Both should be planned together as a system. It was noted that the northwest communities are focused on smart growth and do not want to see sprawl associated with the development of stations. Participants generally agreed with the phasing of MOS as shown by the project team.

Denver Metropolitan Area

Public meeting participants generally felt the numbers behind the study and analysis were solid and decision-making was sound. It



was stated that the recommended phasing was supported, but consideration should be given to the corridor with the greatest traffic congestion and need for an alternative mode of transportation. It was also noted that construction of the MOS should occur opposite that of the commuter rail and that linking to DIA should be the highest priority.

Colorado Springs Area

Colorado Springs participants were very supportive of moving toward a HST system and thinking of the state's future transportation system in a different way. Participants expressed concern over paving more and more lanes on I-25 and looking like Los Angeles. There was support for linking HST service from the south to DIA as that was a critical missing component of the former FREX system. Additionally, the need for more expansive local transit systems that provide local connectivity from the HST station was noted.

Pueblo Area

Participants in Pueblo were strongly supportive of the full Fort Collins to Pueblo ICS LPA that connects the state's population centers with commercial and tourism industry and major airports. Participants were very concerned that Pueblo be included as the southernmost station in the IOS – AGS and first phases of construction so as to ensure critical connections to the Colorado Springs and Denver markets. Participants noted the local interest in providing manpower and steel rail for implementation of the HST system and asked that this become a reality, not just a vision. They also noted a need to think about transportation differently and support modes beyond roadway infrastructure.

In all cases, the verbal and written input at the public meetings was supportive of the study and helped to refine the final ICS LPA.

Section 8: Implementation Plan

This section discusses the challenges and solutions in implementing Colorado’s HST Vision. Specifically, the narrative addresses the methodology for setting phasing priorities, two levels of screening, configuration changes to the Minimum Operating Segments (MOS) to improve cost effectiveness, and the packaging of the MOS options into what was found to be the best performing Initial Operating Segment (IOS). The IOS is defined as an HST system from Fort Collins, south to DIA, and continuing south to Briargate, approximately 10 miles north of downtown Colorado Springs.

This section also includes a Conceptual Financial Plan, which presents the operational viability, simple project payback and performance, projected cash flows, potential sources of funding, and strategies for financing. It is shown that successfully implementing HST in Colorado will rely on federal funding complemented with a new, stable, and secured State funding source, most likely an increase in the sales tax from ½ to 1 cent of each dollar spent.

8.1 Phasing Recommendations

Implementation of Colorado’s HST Vision must be phased due to the large investment required. Nearly every HST system operating in the world has been phased due to financial realities. While HST would be new to Colorado, its phasing can be modeled after decades of experience in other parts of the world and by the California High Speed Rail program. Introducing the state’s population to HST will be necessary to build support for subsequent phases of the program. Based on precedent in other parts of the world, once HST is introduced to the public, demand for the service increases. As the economic success of the program is demonstrated, private investors may be incented to participate.

8.1.1 Levels of Phasing Considered

On the advice of the PLT, the first phase of Colorado’s HST system needs to be an exciting step forward into the future, sufficient to generate support for the revenue enhancements required for implementation. The PLT stated that any initial phase of the HST system has to be successful, which they defined as having a

positive operating ratio, benefits greater than costs, and wide use by the citizens of the State.

Two levels of phasing were considered in the ICS:

1. **Minimum Operating Segment** – Defined as a smaller project that would serve as a component of an IOS and ultimately the ICS LPA.
 - a. MOS Fort Collins to DIA (shown in blue)
 - b. MOS DIA to Briargate (shown in red)
2. **Initial Operating Segment** – A larger project with broad geographic representation that would meet the PLT requirements listed above. Two IOS projects were considered:
 - a. IOS – ICS: Fort Collins to DIA to Briargate
 - b. IOS – AGS: DIA to Eagle County Regional Airport

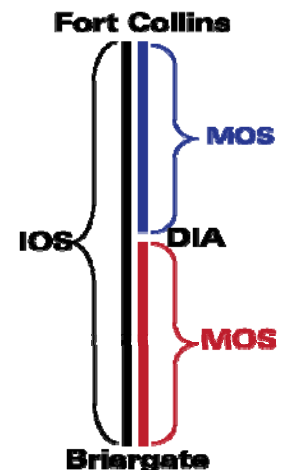

As described below, the screening process started with the review of MOS options, followed by a packaging of the best options into the IOS program.

8.1.2 Methodology for Setting MOS Priorities

Development and recommendation of the best MOS options took place during PLT meetings in August, September, and October 2013. During the August meeting, the group discussed the process for selecting an MOS, possible alternatives, and strategies for reducing costs. The MOS technical evaluations were presented at the September and October 2013 PLT meetings.

8.2 Initial MOS Screening

The six MOS options considered in the Level 3 Evaluation are shown in **Exhibit 8-1**.

EXHIBIT 8-1: MOS OPTIONS CONSIDERED IN THE LEVEL 3 EVALUATION

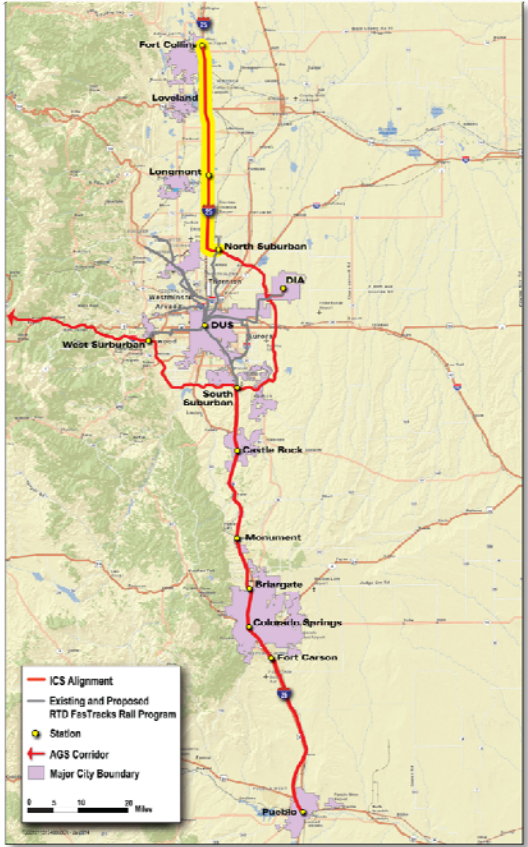
Scope of Project	Description
	<p>MOS 1: North Suburban to Fort Collins</p> <ul style="list-style-type: none"> From the North Suburban Station, the alignment utilizes Union Pacific Railroad (UPRR) ROW, traveling northwest until it reaches I 25. It then continues on ROW on the east side of I-25 through Longmont and Loveland to the end-of-line station near East Prospect Road in Fort Collins, a distance of 40 miles. Stations are located at North Suburban, Longmont/Berthoud, and Fort Collins.

Scope of Project

Description

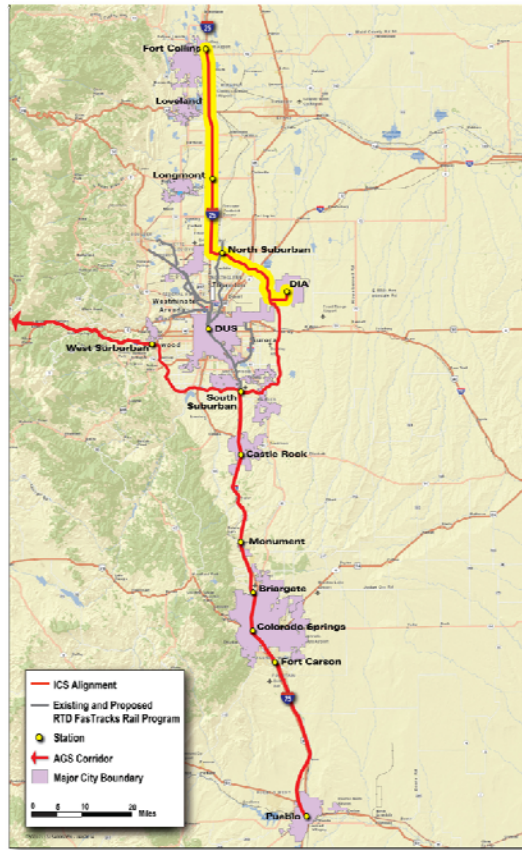
**MOS 1A: DIA to Fort Collins**

- From DIA, the alignment follows E-470 to the North Suburban Station, then travels northwest on UPRR ROW until it reaches I-25. It then travels north using ROW on the east side of I-25 through Longmont and Loveland to the end-of-line station near East Prospect Road in Fort Collins, a distance of 61 miles.
- Stations are located at DIA, North Suburban, Longmont/Berthoud, and Fort Collins.

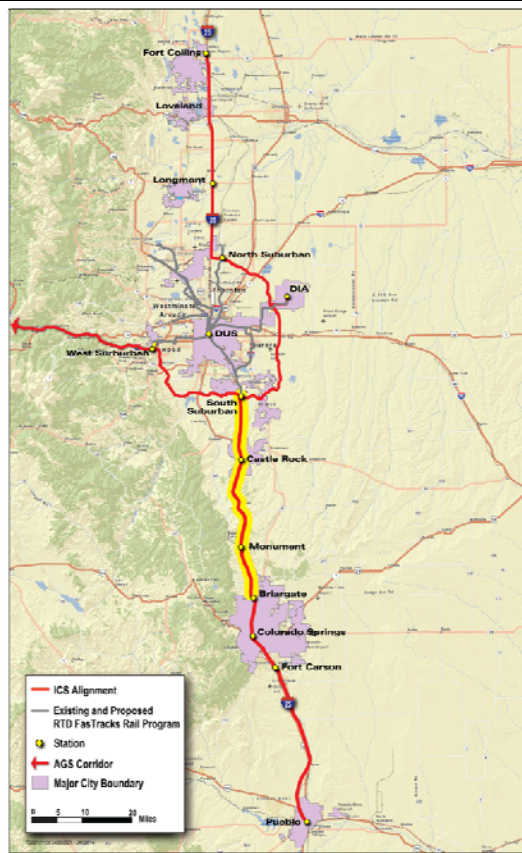
**MOS 2: South Suburban to Colorado Springs (changed to Briargate as shown)**

- From the South Suburban Station, the alignment uses ROW on the east side of I-25 through Castle Rock and Monument until it reaches the Briargate/I-25 Interchange. The interchange is approximately 10 miles north of downtown Colorado Springs. This MOS has a distance of 40 miles.
- Stations are located at South Suburban, Castle Rock, Monument and Briargate.

Scope of Project	Description
	<p>MOS 3: DIA to Colorado Springs (changed to Briargate as shown)</p> <ul style="list-style-type: none"> From DIA, the alignment follows E-470 south to the South Suburban Station, and then uses ROW on the east side of I-25 through Castle Rock and Monument until it reaches the Briargate/I-25 Interchange. The interchange is approximately 10 miles north of downtown Colorado Springs. MOS 3 has a distance of 71 miles. Stations are located at DIA, South Suburban, Castle Rock, Monument and Briargate.
	<p>MOS 4: South Suburban to Monument</p> <ul style="list-style-type: none"> This alignment is exactly the same as MOS 2 except that it terminates in Monument. MOS 4 has a distance of 30 miles. Stations are located at South Suburban, Castle Rock, and Monument.

Scope of Project

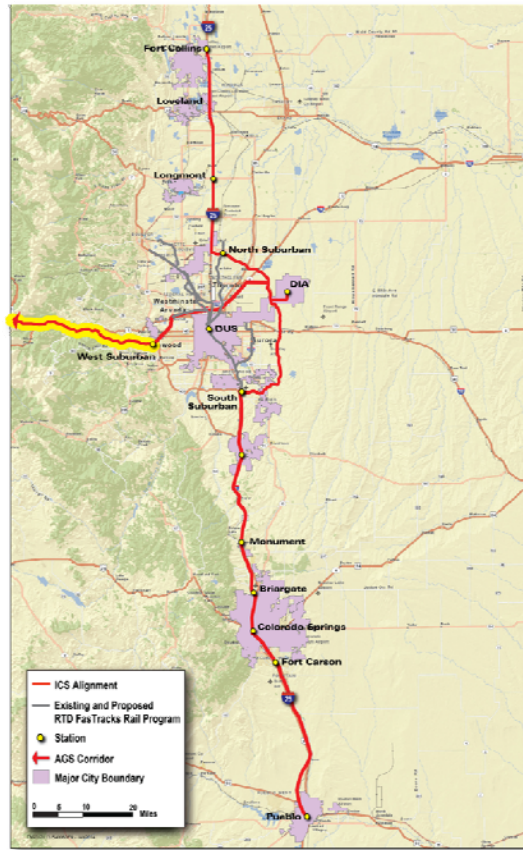

Description

AGS MOS: West Suburban to Breckenridge or Keystone

- Several alignments were forwarded to the ICS team from the AGS team, including segments from the West Suburban Station near Golden to either Keystone or Breckenridge.
- As discussed later in this section, it was found that an MOS would not work well for the AGS corridor because the success of the project is dependent on the capture of the entire market from DIA to Eagle County Regional Airport.
- Stations are located at West Suburban (Golden), Idaho Springs/Georgetown, Keystone, and Breckenridge.

MOS options traveling to Pueblo were not considered for early implementation because of cost – extending the system through the Colorado Springs area south to Pueblo would require about \$3.5 billion. However, based on the public workshop in Pueblo, there is considerable interest in a HST connection to that City.

At the request of the PLT, several AGS MOS options from the West Suburban Station to Keystone, to Breckenridge, and to Eagle County Regional Airport were compared to the ICS MOS options. However, it was determined that an MOS to the mountain communities needed to terminate at the Eagle County Regional Airport in order to capture significant ridership.

8.2.1 Evaluation Criteria

The evaluation criteria used to rank the MOS options included:

- Ability to start construction by 2020
- Cost limited to maximum of \$3 billion (first screening, based on one-third of 1 percent sales tax (0.33 percent) across a 16-county area)
- Supportive of the State’s HST Vision
- Meet cost-effectiveness measures for:
 - Capital Cost (CAPEX)
 - Ridership
 - Revenue
 - Cost per Ride (\$/Ride)
 - Cost per Rider Mile (\$/Rider Mile)

8.2.2 Methods to Improve Cost-Effectiveness

It was also determined that the MOS should be value engineered to optimized its performance. This involved the same cost optimization alternatives considered for the ICS LPA:

- VE Option 1: Single Track Where Possible
- VE Option 2: Passing Track at Stations Only
- VE Option 3: Starter System: Dual-Mode Technology (Starter System)
- VE Option 4: Local Participation for Station Funding

Regarding the single-track analysis, it was generally concluded that VE Option 1 realized superior performance over VE Option 2 due to the latter’s increased travel times.

As documented here, VE Option 3 resulted in lower CAPEX, but its impact on ridership was so severe that it actually reduced cost-effectiveness. Therefore, this option was dismissed from further consideration. VE Option 4 was not pursued; it was assumed that station costs would be paid by local governments, as detailed in Section 8.3, Conceptual Financial Plan.

8.2.3 Initial MOS Screening Results

Exhibits 8-2 through 8-5 present the results of the first full screening analysis conducted using the listed evaluation criteria. A summary of the results is provided below. It should be noted that the CAPEX estimates changed between the initial and final MOS evaluation due to the use of Digital Terrain Mapping (DTM) and refinements to the alignments.

North Suburban Station or DIA to Fort Collins

As shown in **Exhibit 8-2**, using the capital cost per rider-mile (\$/Rider Mile) as an indicator of cost-effectiveness, connecting to DIA under MOS 1A with either VE Option 1 or 2 realizes much greater ridership than MOS 1, which connects the North Suburban Station to Fort Collins. For both MOS 1 and 1A, the use of VE Option 2 saved about 14 percent of CAPEX; however, ridership went down by about 20 percent. In both instances, the MOS options assume that the HST technology would be able to interoperate with RTD’s future North Metro CRT. This assumption was found to generally increase ridership by about 10 percent for all the options evaluated. Thus, interoperability with RTD should be pursued wherever possible for any future Fort Collins segment.

With either MOS 1 or MOS 1A, VE Option 3, the “Starter System”, which assumes the use of dual-mode 110 mph vehicles, resulted in a CAPEX savings but is actually less cost-effective than the other alternatives. This is because the lower cost also resulted in lower ridership causing the \$/Rider Mile metric to increase dramatically as shown on Exhibit 8-2.

It is important to note that the economics of the Fort Collins MOS options changed significantly between the September and October 2013 PLT meetings as new CDOT requirements required movement of the rail alignment from the median of I-25 to the east side of the highway, increasing cost by about \$1.375 billion. This has been found to reduce the cost-effectiveness of all the Fort Collins MOS options.

EXHIBIT 8-2: INITIAL SCREENING OF MOS OPTIONS: NORTH TO FORT COLLINS (BASED ON LEVEL 2 EVALUATION COST ESTIMATES)

ICS MOS Options	CRITERIA				
	CAPEX (B\$)	Ridership	Revenue	\$/Ride	\$/Rider Mile
ICS MOS #1: North Suburban to Fort Collins					
VE Option 1- HSR : Passing track where possible - interoperate with RTD	\$1,728,774,848	\$2,025,559	\$28,550,783	\$49	\$1.13
VE Option 2 - HSR: Passing Track at stations only - interoperate with RTD	\$1,498,287,094	\$1,627,363	\$23,191,899	\$53	\$1.22
VE Option 3 - Starter System (110 mph) - interoperate with RTD	\$1,317,321,448	\$1,142,423	\$16,641,415	\$67	\$1.53
ICS MOS #1A: DIA to Fort Collins					
VE Option 1- HSR : Passing track where possible - interoperate with RTD	\$2,782,092,441	\$3,557,246	\$42,595,706	\$45	\$0.70
VE Option 2 - HSR: Passing Track at stations only - interoperate with RTD	\$2,336,131,972	\$2,294,084	\$29,246,971	\$59	\$0.92
VE Option 3 - Starter System (110 mph) - Interoperate with RTD	\$2,205,426,419	\$1,644,666	\$20,654,307	\$78	\$1.21

EXHIBIT 8-3: INITIAL SCREENING MOS OPTIONS: SOUTH TO COLORADO SPRINGS (BASED ON LEVEL 2 EVALUATION COST ESTIMATES)

ICS MOS Options	CRITERIA				
	CAPEX (B\$)	Ridership	Revenue	\$/Ride	\$/Rider Mile
ICS MOS # 2: South Suburban to Colorado Springs					
VE Option 1- HSR : Passing track where possible - Forced transfer at DIA	\$4,151,721,819	\$2,953,956	\$28,963,434	\$81	\$1.59
VE Option 2 - HSR: Passing Track at stations only - Forced transfer at DIA	\$2,832,433,198	\$2,147,543	\$20,890,973	\$76	\$1.49
VE Option 3 - Starter System (110 mph), interoperable with RTD at S. Suburban	\$1,924,765,778	\$841,243	\$7,859,542	\$132	\$2.58
ICS MOS # 3: DIA to South Suburban to Colorado Springs					
VE Option 1- HSR : Passing track where possible - Forced transfer at DIA	\$5,528,207,452	\$4,340,528	\$53,346,512	\$74	\$0.95
VE Option 2 - HSR: Reduced Service Plan (Passing track at stations only - Forced transfer at DIA)	\$3,992,032,586	\$3,364,479	\$41,683,577	\$69	\$0.88
VE Option 3 - Starter System (110 mph) - interoperable with RTD at DIA and S. Suburban	\$2,908,060,815	\$1,482,192	\$17,380,912	\$113	\$1.46

EXHIBIT 8-4: INITIAL SCREENING MOS OPTIONS: DIA TO MONUMENT (BASED ON LEVEL 2 EVALUATION COST ESTIMATES)

ICS MOS Options	CRITERIA				
	CAPEX (B\$)	Ridership	Revenue	\$/Ride	\$/Rider Mile
ICS MOS # 4: DIA to South Suburban (via E-470) to Monument					
VE Option 1- HSR : Passing track where possible - Forced transfer at DIA	\$4,396,939,141	\$2,553,343	\$22,700,839	\$100	\$1.57
VE Option 2- HSR: Passing track at stations only - Forced transfer at DIA	\$3,229,104,451	\$2,133,702	\$19,853,560	\$87	\$1.39
VE Option 3: Starter System (110 mph), interoperable with RTD at DIA and S. Suburban	\$2,473,657,028	\$1,344,532	\$13,618,764	\$106	\$1.69

EXHIBIT 8-5: INITIAL SCREENING MOS OPTIONS: AGS: WEST SUBURBAN STATION TO BRECKENRIDGE (BASED ON LEVEL 2 EVALUATION COST ESTIMATES)

AGS MOS Options	CRITERIA				
	CAPEX (B\$)	Ridership	Revenue	\$/Ride	\$/Rider Mile
AGS MOS # 1: West Suburban to Breckenridge					
High Speed Rail	\$19	\$515,000	Not calculated	\$2,135	\$35
High Speed Maglev	\$14	\$616,000	Not calculated	\$1,327	\$23
120 mph Maglev	\$6	\$491,400	Not calculated	\$652	\$11

South Suburban to Colorado Springs

As shown in **Exhibit 8-3**, the MOS 3 options connecting DIA to Briargate all exhibit lower \$/Rider Mile performance than the MOS 2 options that connect South Suburban to Briargate. This demonstrates the importance of the DIA connection.

MOS 3 combined with VE Option 2 produced the lowest \$/Rider Mile, at \$0.88. This option had a CAPEX \$1.54 billion lower than the next-best performing option, MOS 3 with VE Option 1, which produced a \$/Rider Mile of \$0.95. However, both options, with respective costs of \$5.5 billion and \$4.0 billion, are greater than the desired \$3 billion MOS budget developed earlier by the PLT.

It should also be noted that the use of MOS 3 with VE Option 3, Starter System, reduced cost by about \$1 billion, but disproportionately lost ridership, resulting in a \$/Rider Mile of \$1.46, which was about 50 percent higher than the best performing options mentioned above. As a result, the Starter System was dismissed from further consideration.

MOS 3 using VE Option 2 was found to be the best candidate for early implementation of a HST system to Briargate.

DIA to Monument

As shown in **Exhibit 8-4**, all of the MOS 4 options from South Suburban to Monument had weaker cost performance than the MOS 3 options from DIA to Briargate, exhibiting \$/Rider mile cost of about 50 percent more. Because the MOS 4 options had no advantage over the MOS 3 options, they were dismissed from further consideration.

AGS MOS: West Suburban Station to Breckenridge

The AGS MOS from the West Suburban Station to Breckenridge or Keystone is not cost-effective when compared to any of the ICS MOS options, as shown in **Exhibit 8-5**. The best performing option assuming high-speed Maglev technology realized a \$/Rider Mile cost more than 20 times higher than the best performing MOS options evaluated for the ICS. However, a HST option to the mountain communities has a high level of localized public support, which may justify it for further consideration.

8.2.4 Final MOS/IOS Screening

At the conclusion of the initial screening, the following determinations set the framework for the final screening of the MOS/IOS options:



1. The concept of high speed should be preserved; thus, any MOS should represent a component of a future HST.
2. HSR or Maglev technologies should be assumed.
3. All the MOS/IOS alignments were designed assuming VE Option 1 (Single Track Where Possible).
4. VE Option 2: (Passing Track at Stations Only) and VE Option 3: Starter System: Dual-Mode Technology (Starter System), were both eliminated from further consideration.
5. Any selected MOS should connect to DIA.
6. The MOS should have a positive OPEX ratio.
7. Additional VE should be performed to further reduce CAPEX.
8. While interoperability with RTD is not critical to the success of the MOS, it should be accommodated where possible, e.g., north to Fort Collins (as interoperation of HST with RTD's Southeast LRT is not probable).
9. The initial project needs to be sufficiently broad geographically to attract statewide support.



8.2.5 Configuration Changes

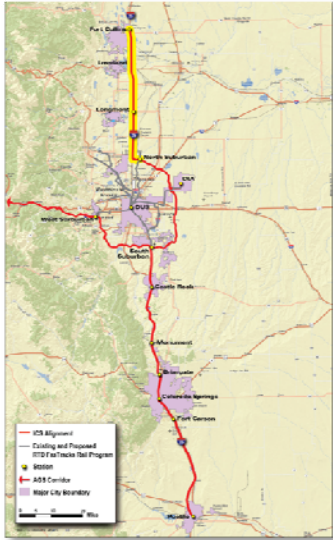

The final MOS/IOS options were reconfigured and further engineered to refine costs and impacts. The MOS options to Fort Collins have been shifted from the median of I-25 to the east side of the highway, which has increased the cost by approximately \$1.375 billion. The MOS options to Colorado Springs have been truncated at Briargate, approximately 10 miles north of downtown Colorado Springs. This was done to reduce environmental impacts and high costs due to constrained ROW conditions entering the urban areas of the City. Further, it is recognized that a future alignment through Colorado Springs to Pueblo will present many environmental and engineering challenges.

Exhibit 8-6 presents the results of the final screening of the MOS/IOS options.

EXHIBIT 8-6: FINAL MOS/IOS SCREENING (BASED ON LEVEL 3 COST ESTIMATES)

Concept	Name	Length (Miles)	CAPEX (Billions)	Annual OPEX (Millions)	Annual Ridership (Millions)	Annual Revenue (Millions)	OPEX Ratio
	<p>MOS 1:</p> <p>North Suburban to Fort Collins</p>	39	\$3.17	\$33.1	2.2	\$28.0	<1.0
	<p>MOS 1A:</p> <p>DIA to Fort Collins</p>	61	\$4.52	\$45.0	4.0	\$46.0	1.02

Concept	Name	Length (Miles)	CAPEX (Billions)	Annual OPEX (Millions)	Annual Ridership (Millions)	Annual Revenue (Millions)	OPEX Ratio
	MOS 2: South Suburban to Briargate	39	\$3.58	\$33.0	5.1	\$39.8	1.2
	MOS 3: DIA to Briargate	61	\$6.03	\$52.0	7.0	\$84.3	1.6

Concept	Name	Length (Miles)	CAPEX (Billions)	Annual OPEX (Millions)	Annual Ridership (Millions)	Annual Revenue (Millions)	OPEX Ratio
	IOS – ICS: Fort Collins to Colorado Springs	132	\$9.81	\$88.2	13.6	\$198.0	2.3
	IOS – AGS: DIA to Eagle County Regional Airport	151	\$16.5	\$78.5	3.5	\$79.3	1.01

8.2.6 Small (<\$3 Billion) MOS Options

It is projected that the implementation of a \$3 billion MOS would require an increase of about 0.33 percent ($\frac{1}{3}$ of a cent for every dollar spent) in new sales taxes assuming no federal funding. With 50 percent federal funding, the amount would be reduced to less than 0.20 percent ($\frac{1}{5}$ th of a cent for every dollar spent).

Of the remaining options, only MOS 1: North Suburban to Fort Collins and MOS 2: South Suburban to Briargate fulfill the under \$3 billion criteria. However, MOS 1 does not have a positive OPEX ratio, whereas MOS 2 has a ratio of 1.2 and is thus favored. MOS 1 has the advantage of interoperability with RTD's North Metro CRT, which is included in the estimate of ridership. Conversely, MOS 2 would require a forced transfer onto RTD's Southeast Corridor LRT due to the likelihood that the HST technology would not be compatible with LRT.

The MOS 2 provides the best cost-effectiveness of the small MOS options. However, limiting the first phase of the HST Vision to MOS 2 was considered to be too small in geographic representation to attract widespread support for funding the project.

8.2.7 Medium (>\$3 to \$6 Billion) MOS Options

It is projected that the implementation of one of the medium-sized MOSs would require an increase of about 0.65 percent ($\frac{2}{3}$ of a cent per dollar spent) in new sales taxes assuming no federal funding. This amount would be reduced with federal funding.

Adding the connection to DIA shows that both the MOS 1A and MOS 3 options have improved performance, with respective ridership of 4 million and 7 million. The MOS 1A option improves to a 1.02 OPEX ratio, and the MOS 3 option improves to an OPEX ratio of about 1.6, which is on the margin of feasibility, as discussed later in this section. The MOS 1A option has the advantage of interoperability with RTD's North Metro CRT for direct access to DUS. The MOS 3 option would require a forced transfer at either the South Suburban or DIA stations to access DUS. Nonetheless, MOS 3 generates more than 3 million additional riders over MOS 1A. Additionally, because CDOT is planning managed lanes along I-25 North, the HST would be forced to the east side, which is anticipated to complicate construction and increase environmental issues, along with the cost increase discussed previously.

Consequently, MOS 3 is considered the best medium-range option. (It is interesting to note that that the RMRA Study also recommended a DIA to Fort Collins MOS as the first phase.)

8.2.8 IOS Options

It is projected that the implementation of one of the IOS projects (several MOS together) would require an increase of about 0.5 percent to nearly 1 percent ($\frac{1}{2}$ to 1 cent per dollar spent) in new sales taxes assuming no federal funding. With federal funding, the amount would be reduced proportionately.

As shown on **Exhibit 8-6**, the IOS – ICS project is significantly more cost-effective than the IOS – AGS project. The capital cost is less than 50 percent, the ridership is nearly four times higher, and the operating ratio is 2.3 versus 1.01. Conversely, the IOS – AGS enjoys very strong local support, has been endorsed by the Programmatic EIS process, and is incorporated into the Record of Decision (ROD). However, because the success of the program is dependent on meeting competitive financial metrics for federal funding, the IOS – ICS program is recommended for initial implementation.

8.2.9 Recommendations

Under ideal conditions, the entire IOS – ICS would be constructed at once. However, based on the anticipated cost of \$9.8 billion, it will likely need to be phased. Based on the criteria used throughout the ICS, the strongest phasing program would include:

- Phase 1: DIA to Briargate
- Phase 2: DIA to Fort Collins
- Future Phase: Briargate to Pueblo
- Future Phase: IOS – AGS: DIA to Eagle County Regional Airport

The completion of Phases 1 and 2 would fully implement IOS – ICS, which realizes the strongest financial performance of the MOS elements evaluated. It also shows stronger financial performance than the HST Vision. It is likely that the start of construction for either Phase 1 or Phase 2 could not occur until 2020 under a best-case scenario. This assumes that a Tier 1 NEPA document would be completed in 2015 and a Tier 2 NEPA document completed by 2018. It also assumes 1.5 years for the preparation of the Request for Proposals (RFP) and bidding of the project. To start

construction in 2020, a design-build project delivery approach is assumed. Under a best-case scenario, the project could be constructed in 5 years, but 6 years is more likely. Based on these assumptions, opening day would occur no sooner than 2025.

The start dates for the Future Phases would depend on funding sources and political support. The phase from Briargate to Pueblo has an estimated cost of \$3.5 billion and an accompanying ridership of about 1 million per year in 2035. The IOS – AGS to the mountain communities has a cost of \$17 billion and an additional annual ridership of 3.5 to 4 million in 2035.

8.3 Conceptual Financial Plan

This section presents the financial analysis and funding strategy for the ICS portion of the HST Vision. The initial narratives describe the operational viability, payback, and performance of the best performing MOS options compared to the full IOS – ICS (Fort Collins/DIA/Briargate).

The financial analysis for the ICS program concludes that:

- The HST Vision, IOS, and recommended MOS options all realize positive operating ratios and have BCA results greater than 1.0; however, the full IOS – ICS performs much better in total than do the two individual component MOS options: MOS 1A and MOS 3.
- A new source of State-enabled funding will be required to implement any portion of the HST system.
- A sales tax increase of from 0.50 to 1 percent ($\frac{1}{2}$ to 1 cent on the dollar) will be required to fund the IOS – ICS, depending on the level of federal funding.
- State support for a new funding source is critical to successfully obtain a federal grant, and both sources will be needed to attract private capital.
- All 16 counties that stand to benefit from HST need to participate in funding (as the leverage of the populated Front Range is needed).
- Local government contributions will optimistically be limited to covering station costs.
- Low-interest funding from RRIF and possibly TIFIA could be used to keep interest rates below 4 percent.

The Conceptual Financial Plan presents the following information:

- Operational Viability
- Project Payback, Cash Flow, and Performance
- Potential Sources of Funding
- Sources of Public Financing

8.3.1 Operational Viability

Revenue and OPEX are discussed in Section 6, Level 3 Evaluation, with more technical detail provided in Appendix C. In general, MOS 1A, MOS 3, and the full IOS – ICS have positive operating ratios in the design year, 2035. These surpluses conservatively assume the high range of the calculated OPEX and are based on a fare of \$0.26 per mile. If the low range of OPEX is considered, revenues would be approximately 30 percent higher. Due to the amount of uncertainty, the more conservative projections form the basis for calculating operating margins in this report.

OPEX does not include major maintenance items such as rebuilding vehicles, or other major capital replacements. These costs are carried as CAPEX and are revealed in the Project Cash Flow Analysis in Section 8.3.3. Additionally, ancillary revenues, advertising, potential income from light freight, etc., are estimated at 3 percent of total fare box revenues. Finally, the operational analysis assumes 2035 revenues. Should any of these phases be operational earlier than that date, the early-year projections will be overstated for the first 10 years and have been adjusted accordingly. It is anticipated that the earliest an initial phase would be operational is 2025.

8.3.2 Project Payback

Exhibits 8-7 through 8-10 show the projected revenue projections for MOS 1A, MOS 3, and the full IOS - ICS. A simple payback calculation is also provided. The simple payback analysis shows the number of years of operation surplus required to pay for the initial CAPEX of the project. While this is a comparatively simplistic financial metric, it does predict the general financial strength of the investment. By comparison, the simple payback for the IOS for the California High Speed Rail program, which is federally funded, is 35 years from the revenue service date.

EXHIBIT 8-7: NET CASH FLOW FROM OPERATIONS – MOS 1A: DIA TO FORT COLLINS

Inputs	Total	Start											Finish 2055
		2026	2027	2028	2029	2030	2031	2032	2033	2034	2035	2036	
Fare Box	\$1,305.48	30.36	32.2	34.04	35.88	37.72	39.56	41.4	43.24	45.08	46	46	46
Ancillary Revenue	\$41.4	1.38	1.38	1.38	1.38	1.38	1.38	1.38	1.38	1.38	1.38	1.38	1.38
Less: OPEX	\$1,350.0	45	45	45	45	45	45	45	45	45	45	45	45
Net Cash	-\$3.1	-\$13.3	-\$11.4	-\$9.6	-\$7.7	-\$5.9	-\$4.1	-\$2.2	-\$0.4	\$1.5	\$2.4	\$2.4	\$2.4
Simple Pay Back													
CAPEX	\$4,250.0												
With Fed \$	NA	Does not have a simple payback											
W/O Fed \$	NA												

EXHIBIT 8-8: NET CASH FLOW FROM OPERATIONS – MOS 3: DIA TO BRIARGATE

Inputs	Total	Start											Finish 2055
		2026	2027	2028	2029	2030	2031	2032	2033	2034	2035	2036	
Fare Box	\$2,392.40	55.6	59.01	62.382	65.754	69.126	72.498	75.87	79.242	82.614	84.3	84.3	84.3
Ancillary Revenue	\$75.9	2.53	2.53	2.53	2.53	2.53	2.53	2.53	2.53	2.53	2.53	2.53	2.53
Less: OPEX	\$1,560.0	52	52	52	52	52	52	52	52	52	52	52	52
Net Cash	\$908.3	\$6.1	\$9.5	\$12.9	\$16.3	\$19.7	\$23.0	\$26.4	\$29.8	\$33.1	\$34.8	\$34.8	\$34.8
Simple Pay Back													
CAPEX	\$6,034.0												
With Fed \$	87 years												
W/O Fed \$	173 years												

EXHIBIT 8-9: NET CASH FLOW FROM OPERATIONS – IOS - ICS

Inputs	Total	Start											Finish	
		2026	2027	2028	2029	2030	2031	2032	2033	2034	2035	2036	2055	
		86,248.8												
Fare Box	\$5,619.2	130.68	138.6	146.52	154.44	162.36	170.28	178.2	186.12	194.04	198	198	\$198.0	
Ancillary Revenue	\$177.0	\$5.9	\$5.9	\$5.9	\$5.9	\$5.9	\$5.9	\$5.9	\$5.9	\$5.9	\$5.9	\$5.9	\$5.9	
Less: OPEX	\$2,646.0	\$88.2	\$88.2	\$88.2	\$88.2	\$88.2	\$88.2	\$88.2	\$88.2	\$88.2	\$88.2	\$88.2	\$88.2	
Net Cash	\$3,150.2	\$48.4	\$56.3	\$64.2	\$72.1	\$80.1	\$88.0	\$95.9	\$103.8	\$111.7	\$115.7	\$115.7	\$115.7	
Simple Pay Back														
CAPEX	\$9,810.0													
With Fed \$	42 years													
W/O Fed \$	84 years													

EXHIBIT 8-10: NET CASH FLOW FROM OPERATIONS – HST VISION

Inputs	Total	Start											Finish
		2026	2027	2028	2029	2030	2031	2032	2033	2034	2035	2036	2055
Fare Box	\$9,691.20	224.4	238	251.6	265.2	278.8	292.4	306	319.6	333.2	342	342	342
Ancillary Revenue	\$306.0	10.2	10.2	10.2	10.2	10.2	10.2	10.2	10.2	10.2	10.2	10.2	10.2
Less: OPEX	\$5,952.0	198.4	198.4	198.4	198.4	198.4	198.4	198.4	198.4	198.4	198.4	198.4	198.4
Net Cash	\$4,045.2	\$36.2	\$49.8	\$63.4	\$77.0	\$90.6	\$104.2	\$117.8	\$131.4	\$145.0	\$153.8	\$153.8	\$153.8
Simple Pay Back													
CAPEX	\$30,100.0												
With Fed \$	98 years												
W/O Fed \$	195 years												

MOS 1A: DIA to Fort Collins

As shown in **Exhibit 8-7**, MOS 1A would run at a deficit for the entire 30-year (to 2054) planning period, with a net operating margin of -\$3.1 million. The deficits are most significant during the first 10 years of operation, starting with -\$13.3 million in the first year (assumed late 2025 to early 2026). The deficit is reduced to -\$5.9 million at year 5 (2030) and is assumed to generate a margin of \$2.4 million in year 10 (2035). MOS 1A does not achieve a simple payback.

MOS 3: DIA to Briargate

As shown in **Exhibit 8-8**, MOS 3 would produce a net operating income of \$6.1 million in the first year of operation. By 2035, this project would realize a net operating margin of \$34.8 million. The net operating margin is \$908 million over the 30-year planning period.

MOS 3 has a simple payback of 87 years with federal funding and 173 years without federal funding.

IOS – ICS: Fort Collins/DIA/Briargate

As shown in **Exhibit 8-9**, the IOS – ICS project would produce a net operating income of \$48.4 million in the first year of operation. By 2035, this project would realize a net operating margin of \$116 million. The net operating margin is \$3.15 billion over the 30-year planning period.

The IOS – ICS has a simple payback of 42 years with federal funding and 84 years without federal funding. While this is longer than the 35 years realized by the California High Speed Rail system, it is respectable considering that the IOS – ICS is a considerably larger project (\$9.8 billion versus \$6.0 billion) than the IOS for the California High Speed Rail program.

HST Vision

As shown in **Exhibit 8-10**, the HST Vision project would produce a net operating income of \$36.2 million the first year of operation, which is about \$12 million less than the IOS – ICS discussed above. By 2035, this project would realize a net operating margin of \$152 million each year of operation. The net operating margin is \$4.0 billion over the 30-year planning period, or about 25 percent greater than the IOS - ICS. However, the HST Vision has a CAPEX approximately three times greater than the IOS – ICS.

The HST Vision has a simple payback of 98 years with federal funding and 187 years without federal

funding. It does not perform as well as the IOS – ICS due to the inclusion of the more costly and comparatively less utilized AGS project.

8.3.3 Project Cash Flow

Conceptual cash flow requirements were calculated for MOS 2, MOS 3, and the IOS – AGS. These results were compared against the HST Vision. The intent of the calculation was to determine the equivalent sales tax required to fund the program.

The cash flow analysis is founded on the following assumptions:

- 50 percent federal funding of initial capital and financial expenses during construction
- Major vehicle overhauls at years 17 to 20 at 50 percent of initial vehicle cost
- Complete replacement of the project systems elements (11 percent of CAPEX) over the 30 years of operation
- Routine maintenance of guideway elements (61 percent of CAPEX) at 0.05 percent of CAPEX per year
- Financial costs during construction of 5 percent of CAPEX
- Local government support of transit station costs at an average of \$25 million per station
- Project operational by late 2025 to early 2026, with a 30-year life to 2055
- Fare box revenue of 66 percent of the design-year (2035) in the initial year of operation, increasing by 4 percent to the 10th year of operation (2034); 100 percent revenues starting in 2035 (which is conservative considering that revenues would actually increase with population and demand after 2035)
- Sales taxes paid by the 12 front range and 4 mountain counties

8.3.4 Project Performance

As stated, under ideal conditions, the full IOS – ICS would be constructed at once as the HST system performs considerably better as a unit than the individual MOS elements. Further, the IOS – ICS outperforms the HST Vision. A discussion of the two MOS options, the IOS – ICS, and the HST Vision is provided below. Cash flow requirements are shown in **Exhibits 8-11 through 8-14**.

EXHIBIT 8-11: CONCEPTUAL CASH FLOW REQUIREMENTS – MOS 1A: DIA TO FORT COLLINS

Inputs	Total	Start							Finish
		2026	2035	2041	2042	2043	2044	2055	
Requirements									
CAPEX	\$4,516.0								
CAPEX Replacement - Vehicles (Yr 17 - 20)	\$140.0			\$35.0	\$35.0	\$35.0	\$35.0		
CAPEX Replacement - Systems @ 3.3% of Systems CAPEX	\$491.7	\$16.4	\$16.4	\$16.4	\$16.4	\$16.4	\$16.4	\$16.4	\$16.4
CAPEX Replacement - Guideway @.005% CAPEX	\$406.5	\$13.6	\$13.6	\$13.6	\$13.6	\$13.6	\$13.6	\$13.6	\$13.6
Financial Cost During Construction @5%	\$225.8								
Total CAPEX	\$5,780.0								
Funding Sources									
Federal Funding @ 50%	\$2,370.9								
Local Contributions (stations)	\$100.0								
Remaining CAPEX	\$3,309.1								
Capital Recovery	\$191.27	\$191.27	\$191.27	\$191.27	\$191.27	\$191.27	\$191.27	\$191.27	\$191.27
Income									
Fare Box	\$1,305.48	30.36	46	46	46	46	46	46	46
Ancillary Revenue @ 3% of fare box	\$41.40	1.38	1.38	1.38	1.38	1.38	1.38	1.38	1.38
Less: OPEX	\$1,350.0	\$45.0	\$45.0	\$45.0	\$45.0	\$45.0	\$45.0	\$45.0	\$45.0
Net Cash	-\$3.1	-\$13.3	\$2.4	\$2.4	\$2.4	\$2.4	\$2.4	\$2.4	\$2.4
Shortfall		-\$204.53	-\$188.89	-\$188.89	-\$188.89	-\$188.89	-\$188.89	-\$188.89	-\$188.89

EXHIBIT 8-12: CONCEPTUAL CASH FLOW REQUIREMENTS: MOS 3: DIA TO BRIARGATE

Inputs	Total	Start							Finish
		2026	2035	2041	2042	2043	2044	2055	
Requirements									
CAPEX	\$6,034.0								
CAPEX Replacement - Vehicles (Yr 17 - 20)	\$200.0			\$50.0	\$50.0	\$50.0	\$50.0		
CAPEX Replacement - Systems @ 3.3% of Systems CAPEX	\$657.0	\$21.9	\$21.9	\$21.9	\$21.9	\$21.9	\$21.9	\$21.9	\$21.9
CAPEX Replacement - Guideway @.005% CAPEX	\$543.0	\$18.1	\$18.1	\$18.1	\$18.1	\$18.1	\$18.1	\$18.1	\$18.1
Financial Cost During Construction @5%	\$301.7								
Total CAPEX	\$7,735.7								
Funding Sources									
Federal Funding @ 50%	\$3,167.9								
Local Contributions (stations)	\$125.0								
Remaining CAPEX	\$4,442.9								
Capital Recovery	\$256.80	\$256.80	\$256.80	\$256.80	\$256.80	\$256.80	\$256.80	\$256.80	\$256.80
Income									
		55.638	84.3						
Fare Box	\$2,392.40	55.6	84.3	84.3	84.3	84.3	84.3	84.3	84.3
Ancillary Revenue @ 3% of fare box	\$75.90	2.53	2.53	2.53	2.53	2.53	2.53	2.53	2.53
Less: OPEX	\$1,560.0	\$52.0	\$52.0	\$52.0	\$52.0	\$52.0	\$52.0	\$52.0	\$52.0
Net Cash	\$908.3	\$6.1	\$34.8	\$34.8	\$34.8	\$34.8	\$34.8	\$34.8	\$34.8
Shortfall		-\$250.67	-\$221.97	-\$221.97	-\$221.97	-\$221.97	-\$221.97	-\$221.97	-\$221.97

EXHIBIT 8-13: ICS IOS: (FORT COLLINS/DIA/BRIARGATE)

Inputs	Total	Start							Finish
		2026	2035	2041	2042	2043	2044	2055	
Requirements									
CAPEX	\$9,810.0								
CAPEX Replacement - Vehicles (Yr 17 - 20)	\$280.0			\$70.0	\$70.0	\$70.0	\$70.0		
CAPEX Replacement - Systems @ 3.3% of Systems CAPEX	\$1,079.1	\$36.0	\$36.0	\$36.0	\$36.0	\$36.0	\$36.0	\$36.0	\$36.0
CAPEX Replacement - Guideway @.005% CAPEX	\$882.9	\$29.4	\$29.4	\$29.4	\$29.4	\$29.4	\$29.4	\$29.4	\$29.4
Financial Cost During Construction @5%	\$490.5								
Total CAPEX	\$12,542.5								
Funding Sources									
Federal Funding @ 50%	\$5,150.3								
Local Contributions (stations)	\$175.0								
Remaining CAPEX	\$7,217.3								
Capital Recovery	\$417.16	\$417.16	\$417.16	\$417.16	\$417.16	\$417.16	\$417.16	\$417.16	\$417.16
Income									
Fare Box	\$5,619.2	130.68	198	\$198.0	\$198.0	\$198.0	\$198.0	\$198.0	\$198.0
Ancillary Revenue @ 3% of fare box	\$178.2	5.94	5.94	5.94	5.94	5.94	5.94	5.94	5.94
Less: OPEX	\$2,646.0	\$88.2	\$88.2	\$88.2	\$88.2	\$88.2	\$88.2	\$88.2	\$88.2
Net Cash	\$3,151.0	\$48.4	\$115.7	\$115.7	\$115.7	\$115.7	\$115.7	\$115.7	\$115.7
Shortfall		-\$368.74	-\$301.42	-\$301.42	-\$301.42	-\$301.46	-\$301.46	-\$301.46	-\$301.46

EXHIBIT 8-14: HST VISION

Inputs	Total	Start							Finish
		2026	2035	2041	2042	2043	2044	2055	
Requirements									
CAPEX	\$30,100.0								
CAPEX Replacement - Vehicles (Yr 17 - 20)	\$550.0			\$137.5	\$137.5	\$137.5	\$137.5		
CAPEX Replacement - Systems @ 3.3% of Systems CAPEX	\$3,168.5	\$109.3	\$109.3	\$109.3	\$109.3	\$109.3	\$109.3	\$109.3	\$109.3
CAPEX Replacement - Guideway @.005% CAPEX	\$2,618.7	\$90.3	\$90.3	\$90.3	\$90.3	\$90.3	\$90.3	\$90.3	\$90.3
Financial Cost During Construction @5%	\$1,505.0								
Total CAPEX	\$37,942.2								
Funding Sources									
Federal Funding @ 50%	\$15,802.5								
Local Contributions (stations)	\$425.0								
Remaining CAPEX	\$21,714.7								
Capital Recovery	\$1,255.11	\$1,255.11	\$1,255.11	\$1,255.11	\$1,255.11	\$1,255.11	\$1,255.11	\$1,255.11	\$1,255.11
Income									
Fare Box	\$9,349.20	224.4	342	342	342	342	342	342	342
Ancillary Revenue	\$295.8	10.2	10.2	10.2	10.2	10.2	10.2	10.2	10.2
Less: OPEX	\$5,753.6	198.4	198.4	198.4	198.4	198.4	198.4	198.4	198.4
Net Cash	\$3,891.4	\$36.2	\$153.8	\$153.8	\$153.8	\$153.8	\$153.8	\$153.8	\$153.8
Shortfall		-\$1,218.91	-\$1,101.31	-\$1,101.31	-\$1,101.31	-\$1,101.31	-\$1,101.31	-\$1,101.31	-\$1,101.31

MOS 1A: DIA to Fort Collins

As shown in **Exhibit 8-11**, MOS 1A would require a total capital outlay of \$5.78 billion. Of this amount, federal funding would cover \$2.37 billion, leaving \$3.31 billion to be financed. (Note that future capital replacement costs are not included in federal funding assumptions.) At 4 percent interest, this would result in a capital recovery requirement of \$191.27 million per year. After operating revenues are included (discussed earlier), the projected shortfall is \$204 million in the initial 5 years of operation and levels off to -\$188.9 million per year by 2035. The sales tax equivalent required to fund the project shortfall is 0.34 percent.

MOS 3: DIA to Briargate

As shown in **Exhibit 8-12**, MOS 3 would require a total capital outlay of \$7.73 billion. Of this amount, federal funding would cover \$3.17 billion, leaving \$4.44 billion to be financed. At 4 percent interest, this would result in a capital recovery requirement of \$256.8 million per year. After operating revenues are included (discussed earlier), the projected shortfall is as much as \$250.7 million in the initial year of operation, levels off to \$221.9 million by year 10, and remains at this value for the remainder of the project life. The sales tax equivalent required to fund the project shortfall is 0.39 percent.

IOS - ICS

As shown in **Exhibit 8-13**, IOS – ICS would require a total capital outlay of \$12.54 billion. Of this amount, federal funding would cover \$5.15 billion, leaving \$7.22 billion to be financed. At 4 percent interest, this would result in a capital recovery requirement of \$417.16 million per year. After operating revenues are included (discussed earlier), the projected shortfall is as much as \$368.74 million in the initial year of operation, levels off to \$301.42 million by year 10, and remains at this value for the remainder of the project life. The sales tax equivalent required to fund the project shortfall is 0.53 percent.

HST Vision

As shown in **Exhibit 8-14**, the HST Vision would require a total capital outlay of \$37.94 billion. Of this amount, federal funding would cover \$15.80 billion, leaving \$21.71 billion to be financed. At 4 percent interest, this would result in a capital recovery requirement of \$1.26 billion per year. After operating revenues are included (discussed earlier), the

projected shortfall is as much as \$1.22 billion in the initial year of operation, levels off to \$1.10 billion by year 10, and remains at this level for the remainder of the project life. The sales tax equivalent required to fund the project shortfall is 1.9 percent.

8.3.5 Potential Sources of Funding

At the writing of this ICS Final Report, there are no known committed sources of funding for any portion of the HST Vision. As stated earlier, the success of the program is predicated on State-enabled support for a new revenue source, which in turn is anticipated to develop support for federal funding.

A variety of funding options and sources were assessed to determine the potential level of revenue that could be used to help fund HST in Colorado. There was a broad-based discussion at the PLT meetings about different resources, including a wide variety of alternative funding sources. Possible sources of funding are discussed below.

Local Funding

In general, local sources of funding are limited for an HST system. However, the use of local funds demonstrates public support and commitment to the program, which are important factors for successful award of a federal grant. The sources discussed below could demonstrate local support; however, as of the conclusion of this ICS, none are committed. As a proxy for a local source of funding, it has been assumed that local government will fund the construction and maintenance of the HST stations. For the purposes of cost estimating, the budgetary allowance for a HST station is \$25 million. Local governments would be empowered to modify the budgets for their stations, so long as they fulfill industry standards for operation and safety.

Local sources of funding are those that apply only to limited geographic areas, usually a county, city, or special district. In effect, the sources listed below (for informational purposes only) could potentially be implemented on a localized scale to fund specific projects or portions of a project within the jurisdiction where the dollars were generated. The sources typically require voter approval, constitutional amendments, property owner approval, or some combination of these.

- **Local Tax Increase** – Local taxes could be increased to generate revenue specifically designated for use in the effected jurisdiction.

- **Special Taxing Districts** – New taxing districts could be created from which the revenue generated could be applied to improvements within a specific part of the HST corridor.
- **Urban Renewal Districts** – Urban Renewal Authorities are quasi-municipal organizations created to halt the spread of “blight” and redevelop deteriorating areas. The Authorities have a broad array of powers including the use of eminent domain and tax increment financing (TIF). A HST Urban Renewal Corridor District could potentially be considered to capture the tax increment generated from new development adjacent to the corridor.
- **Tax Increment Financing** – Commonly used with special districts, such as Urban Renewal Districts, this public financing method leverages future revenue sources from property and sales tax increments to pay for public infrastructure improvements today. The tax increment is the increase in taxes resulting from an increase in site values and private investments from redevelopment in a district.
- **Other Special Districts**
 - **Business Improvement District (BID)** – A BID can be created for the purpose of constructing public improvements and supporting economic and business development. It can only cover commercial properties. It can levy and collect property taxes and impose fees or charges for services. A BID can also issue general obligation and revenue bonds.
 - **General/Public Improvement Districts (GIDs/PIDs)** – Cities create GIDs and counties can create PIDs. These districts are most useful in financing public improvements for a specific designated area. The districts can issue general obligation or revenue bonds. Property tax revenues, rates, tolls, and charges can be used pay back the bonds.
 - **Special/Local Improvement Districts (SIDs/LIDs)** – Cities create SIDs and counties create LIDs. This type of district is most useful in financing public improvements where the benefits enhance a designated area and can be attributable to properties along the improvement (i.e., streetscapes).
- Special assessments or general obligation bonds can be used as financing tools.
- **Real Estate Transfer Tax** – A tax on real estate sales along the HST corridor could be implemented and the revenues applied to improvements in the corridor. While widely used, particularly in the mountain communities, TABOR (the Taxpayer’s Bill of Rights) would need to be amended in order to put new taxes into place. In addition to mandating a vote on any new tax increase, TABOR bars four types of taxes, including new or increased real estate transfer taxes.
- **Lodging Tax** – These taxes are typically instituted by municipalities with proceeds often going toward marketing, promotional events, and other activities to help promote tourism, which benefits the lodging industry. Because any HST system would benefit the State’s tourism industry, a regional lodging tax could be considered for use in the HST corridor.

State Funding

Due to the potential to leverage larger populations, State sources are the most promising for funding an HST system. Possible increases in the State sales tax have been considered as a complementary funding source for transportation projects in recent years. Special taxing entities, such as Regional Transportation Authorities (RTA), also have been considered. To date, there are no imminent commitments for a new State funding source for transportation and no defined RTA.

The study team examined the following State sources for funding HST:

- User Fees
 - Transit Fares
 - Motor Fuels Tax Increase
 - VMT Fees
 - Utility fees
- General Revenues
 - Sales and Use Taxes
 - State Income Taxes
 - Property Taxes
 - Lodging Taxes
 - Lottery Tax Reallocation
- Value Capture Mechanisms
 - Development Fees

The Level 2 Evaluation more specifically outlined the potential revenues that could be generated from each of these sources.

Each of the potential funding sources has pros and cons, which were assessed using the following criteria:

- **Stability** – Will the revenue sources remain relatively constant with the ebb and flow of the economic cycle?
- **Revenue Potential** – Will the source generate sufficient amounts of revenue?
- **Growth Potential** – Will the source grow commensurately with inflation?
- **Transportation Efficiency** – Are the revenues structured in such a way to encourage efficient use of the transportation system?
- **Fiscal Efficiency** – Are the taxes, fees, etc. easy to collect and understand and easy to administer?
- **Equity** – Does the source disproportionately impact lower income people? Do users who use the system more pay more for the benefits?
- **Impact on Competitiveness** – Would the tax/fee place an onerous burden on residents, businesses, and visitors, creating a disincentive to live, work, or recreate in the area?

In order to help assess the relative attractiveness of the State funding sources, a matrix was created of the criteria, and the sources were assessed using a scale of 1 to 10 to create a rank for each potential revenue source. A “1” represents the lowest ranking, “10” the highest, and “5” is neutral. Each of the criteria was weighted evenly. The total rankings for each funding source represents its overall relative attractiveness as a funding tool for HST.

The project team presented a simplified version of the matrix to the PLT for evaluation and comment, as approximated in **Exhibit 8-15**. While the PLT meeting primarily focused on whether a revenue source was equitable, the scores reflect the PLT’s general support (or lack of support) for the alternative funding sources. Transit fares received the highest support from the PLT, while the other revenue sources received only medium to low support (see **Exhibit 8-15**). The most acceptable revenue sources other than transit fares were those that taxed non-residents such as lodging taxes or could be perceived as “sin taxes,” i.e., lottery taxes. Although they could

contribute revenue, these sources do not raise funding significant enough to implement an HST system.

The more robust sources – sales, income, property, motor fuels, and VMT taxes – were not ranked highly by the PLT. Despite their unpopularity, funding sources such as the State income tax received a high score on other criteria, primarily because they would be very stable sources with the potential to generate high amounts of revenue.

The presentation to the PLT generated conversation and comments regarding geographic equity. Alternative taxes on revenues resulting from station development, high value freight, energy development, and advertising also were discussed. Potential increases on general revenue taxes, such as income taxes that more directly affect residents, were not as well supported (see **Exhibit 8-15**).

Recognizing that no new tax will be highly supported without a proportionately higher perceived public benefit, the study team used a sales tax equivalent to communicate the tradeoffs between a new tax and the benefits of HST. Thus, public support for the HST system can be determined by comparing the geographic scope of the project to increments in new sales tax. For example, how much of the HST system could be built for a 0.5 cent per dollar tax increase versus a more aggressive tax such as a 1 cent per dollar increase? The increases were calculated assuming 50 percent federal funding, which dramatically reduces the level of sales tax required.

Sales Taxes Sensitivity Analysis

In order to alleviate the risk of revenues sources, such as transit fares, which can be volatile, the HST financing will need to be supported by one or more broad-based predictable revenue sources such as a sales tax, income tax, and/or motor fuel or vehicle tax. Sales taxes have been a tool to generate funds for a variety of infrastructure and other public improvements, partially because of their potential to generate substantial revenue, their relative stability (although overoptimistic sales tax revenue projections has been a challenge to many public transportation programs), and the perception that they have higher impact on those with higher retail expenditures, that is, higher income households. They have been a popular source to turn to for transportation funding in Colorado, so their potential use was further explored.

EXHIBIT 8-15: STAKEHOLDER EVALUATION OF REVENUE-GENERATING TAX ALTERNATIVES

Revenue Source	Revenue Criterion							TOTAL
	Financial Effectiveness			Transportation Efficiency	Fiscal Efficiency	Equity	Impact on Competitiveness	
	Stability	Revenue Potential	Growth Potential					
User Fees								
Transit Fares	8	4	4	5	9	5	5	40
Motor fuels tax increase	8	8	8	7	9	2	1	43
VMT Fees	8	8	8	7	7	3	1	42
Utility Fees	8	5	8	1	8	5	2	37
General Revenues								
Sales and Use Tax	9	10	10	2	9	2	2	44
State Income Tax	9	10	10	2	9	8	2	50
Property Tax	7	4	9	2	9	8	2	41
Lodging Tax (Visitor Fee proxy)	7	1	7	2	9	5	5	36
Lottery Tax Reallocation	8	1	7	2	9	5	9	41
Value Capture Mechanisms								
Development Fee	6	3	7	5	7	8	2	38

Source: Table format based on "Metropolitan-Level Transportation Funding Sources" by Institute of Transportation Studies, Berkeley, CA and ICF Consulting, December 2005, ArLand.

A sensitivity analysis was undertaken to determine how high the sales tax would need to rise in order to finance the cost of constructing the project, assuming a 30-year bond and a 4 percent interest rate. Through PLT feedback, it was determined that a sales tax increase substantially over 1 percent would be difficult for the public to accept, unless it was accompanied by a substantial buildout of the system.

Other than local funding of the HST stations, the analysis does not assume other sources of funding, which would be unlikely, given the number of different sources, including federal sources, that are typically used to fund transportation projects.

In order to provide parameters for a discussion, a variety of different phasing scenarios were analyzed with associated costs and potential sales tax impacts. Impacts were analyzed for two different geographic areas – just the 16 counties that would most directly benefit from the system and the entire State.

Exhibit 8-16 shows the estimated sales tax requirement for each phasing option.

These estimates do not assume any federal funding. With 50 percent federal funding, the sales tax requirement is typically reduced by 40 percent. This is because the sales tax estimate includes cost for future CAPEX such as rebuilding vehicles, a cost that would not be covered by federal funding.

EXHIBIT 8-16: SALES TAX REQUIREMENTS BY PHASE

Name of Phase	CAPEX (Billions \$)	Annual Revenue Needed (Millions \$)	Sales Tax Impact (%) (16 counties)	Sales Tax Impact (%) Statewide
MOS 1A: DIA to Fort Collins	\$5.78	\$188.9	0.34%	0.28%
MOS 3: DIA to Briargate	\$7.74	\$222.0	0.39%	0.33%
IOS-ICS: Fort Collins to Briargate	\$12.5	\$301.5	0.53%	0.44%
HST Vision	\$37.9	\$1,101.3	1.93%	1.62%

Federal Funding

Federal grant contributions may be obtained in the future under New Starts or another similar transit or rail program, for potential improvements to local systems that would complement the development of an HST system. While the American Recovery and Reinvestment Act (ARRA) made \$8 billion available to the states, soliciting competitive grant applications for the development of HST passenger service in federally designated corridors, the development of HST has been politically controversial and the current funding outlook for substantial federal support is questionable.

Federal Railroad Administration (FRA)

In 2009, the Obama administration announced a plan for developing high-speed passenger rail in a national network of corridors in a collaborative effort among the federal government, states, railroads, and other key stakeholders. The FRA was charged with managing the HSIPR Program through the Passenger Rail Investment and Improvement Act (PRIIA) and ARRA.

In addition to the \$8 billion that ARRA made available to the states, Congress made another \$2.1 billion available through annual appropriations for Fiscal Years (FY) 2009 and 2010, using the framework initially established by PRIIA to bring program funding to \$10.1 billion. This legislation expired at the end of FY 2013.

PRIIA authorized the National Railroad Passenger Corporation (Amtrak) and strengthens the U.S. passenger rail network by tasking Amtrak, the USDOT, FRA, states, and other stakeholders to improve rail service, operations, and facilities. PRIIA focuses on intercity passenger rail, state-sponsored corridors throughout the nation, and development of HST corridors. PRIIA also authorizes the

appropriation of funds to the USDOT to establish and implement a HST corridor development program.

The FRA is requesting \$6.6 billion for rail safety and investment programs for FY 2014. FRA is also requesting a 5-year, \$40-billion rail authorization. Funding for PRIIA, which expired on September 30, 2013, is part of the request. The PRIIA negotiation will put the future of HST funding into focus.

Federal Transit Administration (FTA)

The FTA's Capital Investment Grant Program, most recently authorized by MAP-21, is the federal government's primary financial resource for supporting major transit capital projects that are locally planned, implemented, and operated. The majority of the projects are fixed-guideway transit projects. Under MAP-21, the Capital Investment Grant Program includes three categories of eligible projects, referred to as New Starts, Core Capacity, and Small Starts. New Starts projects are those whose sponsors request \$75 million or more in Capital Investment Grant Program funds or have an anticipated total capital cost of \$250 million or more. Core Capacity projects are substantial corridor-based investments in an existing fixed-guideway system that will increase capacity in the corridor by not less than 10 percent. Small Starts projects are those whose sponsors request less than \$75 million in Capital Investment Grant Program funds and have an anticipated total capital cost of less than \$250 million.

The FTA is recommending a total appropriation of \$2.1 billion in FY 2014 for the Capital Investment Grant Program. There have been fluctuations in funding for this segment of the FTA's budget in the past 5 years, from \$1.6 billion to \$3.2 billion. Budget constraints and a lack of consensus regarding the

federal role in key infrastructure sectors present an ongoing challenge, as does the short-term timeframe of transportation program reauthorizations.

Support received from these programs would be for improvements to local programs which could potentially support the broader HSR system. The \$2 billion Eagle P3 Commuter Rail project is receiving substantial support from New Starts (\$1 billion) in addition to a range of other transit sources.

Other Possible Funding – Freight

High-speed rail systems generally compete with air service in terms of freight carrying markets because of the similarities in travel times and carrying capacity. The most common freight carried in conjunction with high-speed rail is mail and high value/high priority/time sensitive materials.

Because of the system requirements and speed differential potential between heavy freight and passenger service, it is difficult to carry any type of bulk freight over a high-speed passenger rail system. Another category of freight that may be addressable by a high-speed rail system is warehouse/distribution freight. The cost to transport this type of freight by rail instead of by truck within Colorado could significantly limit the amount and type of freight that would be desirable to transport by rail but the value of increased reliability may offset this characteristic. An example of an addressable freight type like this is UPS. UPS currently uses heavy freight rail to transport a significant portion of its packages across the US because of long distance haul cost benefits and reliability benefits. This reliability factor could also be a good selling point as roadway and airport congestion grows. Also, one of FedEx's biggest worries during the 2013 Holiday season was the potential for bad weather in Louisville that would disrupt their high speed delivery operations. If they had access to a high-speed rail network to move some of their freight, they may view that as a significant reliability benefit.

There are three potential models for using high-speed passenger rail infrastructure for freight service:

- Interlining freight and passenger service: Separate passenger and freight train sets are interlined on the same track.
- Temporal separation: the high-speed passenger rail system carries freight in the late night/early

morning hours when passenger trains are not in service.

- Mixed train sets: One or several cars in the passenger train set are configured for carrying light freight throughout the day.

Interlining freight and passenger train sets is difficult if the freight and passenger vehicles have significantly different operating speeds. Examples of some systems around the world that use this method are TGV in France and ICE in Germany. TGV Poste in France uses specially designed TGV high speed trains that carry only mail and they are interlined with other TGV passenger rail service.

Since they are essentially the same train, they travel at similar speeds and interline effectively at any time of the day depending on demand. Germany has used relatively fast freight trains interlined with high-speed passenger service on their ICE service. The freight trains in this system travel at about 1/2 to 2/3 the passenger train speed so they are used in off peak periods when the spacing between passenger trains is greater so they can make the trip without greatly disrupting passenger service. One interesting difficulty the ICE system had with freight was the tendency of freight cars to lose material in tunnels due to the different aerodynamic characteristics of the freight cars as compared to the passenger cars. This was addressed by making minor modifications to the freight cars to change their aerodynamic characteristics.

Temporal separation resolves potential speed differential issues between freight and passenger train sets but as a result has a limited window of operation that limits the potential benefits of this type of service. Since freight is only carried overnight, many high value freight types that are addressable by a high speed rail system are not adequately served by this model.

Using mixed train sets addresses the speed differential issue by including freight cars in the passenger car train sets. Since freight and passenger service are linked in the same train set, this model has the potential to disrupt passenger travel times if there are any issues with loading/unloading freight from the freight cars. Because of this difficulty, this type of operation usually uses a palette or container system for freight and special cars with larger side doors to access the freight in an efficient and timely manner.

It is safe to say that in Colorado there is at least a small market of high cost/high value/time sensitive items that could be carried via a high-speed rail system resulting in a benefit to the region. The mail/package business could be run with the mixed train set model by utilizing either a few separate freight specific cars in the passenger train sets or making minor modifications to the passenger cars to accommodate mail/packages. A tracking system and fast and efficient loading/unloading schemes would need to be implemented to operate this type of service but the logistical hurdles to implementation are relatively small.

8.3.6 Sources of Public Financing

There are several sources of low-interest public financing for projects with identified and secured sources of funding. However, these loans are not available without a source of funding. Several promising sources of low-interest finance are discussed below.

Local

Private Activity Bonds

Private Activity Bonds (PABs) are tax-exempt bonds that are issued by the state or local government on behalf of a private entity. Their purpose is to facilitate private investment for projects that generate public benefit. PABs allow for the private sector to borrow at tax-exempt rates resulting in lower overall financing costs. Currently, any PABs issued for HST would be subject to a volume cap of the respective state; however, a new category of exempt facilities was created under SAFETEA-LU, continuing under MAP-21, that allows projects receiving Title 23 funds, and under certain conditions Title 49 funds, to qualify for the \$15 billion in transportation PABs. The Secretary of Transportation and the USDOT are responsible for the allocation of these PABs.

PABs are highly attractive to private investors in conjunction with a public-private partnership (P3) program that includes equity investment, design-build, and operations involvement and could be used in conjunction with TIFIA/RRIF. For example, PABs were recently used in the financing of the \$1.9-billion Capital Beltway project in Northern Virginia, one of the first variable toll rate congestion pricing projects in the country.

Regional

Regional Transportation Authorities

Formerly known as Rural Transportation Authorities, the state legislature broadened the rural authority to regional or a statewide authority in 2005. Prior to the passage of this legislation, every area of the state except the Denver Metro area was allowed to form Regional Transportation Authorities. Currently, a Regional Transportation Authority allows two or more jurisdictions, including the Denver Metro area, to form a taxing authority in order to fund local transportation projects. An Intergovernmental Agreement between the Regional Transportation Authorities and CDOT is required prior to taking it to a vote of the people of the region in order to form and fund a transportation project on the State highway system.

Per Colorado Revised Statute (CRS) 43-4-605, Regional Transportation Authorities have the following means to obtain revenue:

- Annual motor vehicle registration fee up to \$10 (for persons residing within authority boundaries)
- Portion of visitor benefit tax (collected within authority boundaries)
- Sales and use tax
- Mill levy authority (up to 5 mills) on all taxable property (this measure expires in 2019)

Currently, there are four Regional Transportation Authorities statewide, including the Baptist Road Rural Transportation Authority, the Gunnison Rural Transportation Authority, the Pikes Peak Rural Transportation Authority, and the Roaring Fork Rural Transportation Authority.

Federal

Railroad Rehabilitation and Improvement Financing Program (RRIF)

The RRIF program is a revolving loan and loan guarantee program administered by the FRA. It is legislatively enabled to issue up to \$35 billion in loans. The program originally was established by the TEA-21, and was amended by SAFETEA-LU and MAP-21. MAP-21 modifies the RRIF program to allow applicants to use future dedicated revenues or income as collateral to help secure a RRIF loan,

helping commuter and passenger rail projects more effectively obtain RRIF loans.

Funding from RRIF may be used to acquire, improve, or rehabilitate intermodal or rail equipment or facilities, including track, components of track, bridges, yards, buildings, and shops. Funds also may refinance outstanding debt incurred for these purposes or may be allocated to develop or establish new intermodal railroad facilities.

Attractive interest rates, similar to those available under TIFIA, also exist under RRIF. This program is able to fund up to 100 percent of a project's costs, allows for a five-year grace period, and requires the payment of an up-front risk premium.

A RRIF loan could be combined with a TIFIA loan. This combination of loans is being used at Denver Union Station. It is important to note that these sources are loans and will need to be repaid.

Transportation Infrastructure Finance and Innovation Act (TIFIA)

TIFIA is an established federal credit assistance program for eligible transportation projects of national or regional significance. These include transit and passenger rail facilities, such as the California High Speed Rail project. Under TIFIA, the USDOT can provide three forms of credit assistance to eligible projects:

- Secured (or direct) loans
- Loan guarantees
- Standby lines of credit

TIFIA can help advance qualified, large-scale projects that otherwise might be delayed or deferred because of size, complexity, or uncertainty over the timing of revenues. Many surface transportation projects – highway, transit, railroad, intermodal freight, and port access – are eligible for assistance. The fundamental goal of TIFIA is to leverage federal funds to attract substantial private and other non-federal co-investment into projects that provide critical improvements to U.S. surface transportation. Interest rates for TIFIA loans generally reflect the government's borrowing costs, and the terms of repayment are generally favorable to project sponsors. There are three TIFIA-approved projects in Colorado: US 36 Managed Lanes (\$54 million), Denver Union Station (\$146 million), and Eagle P3 Commuter Rail (\$280 million).

Update on TIFIA Loans

TIFIA Loans have been the backbone to underpin infrastructure development and project financing for U.S. transportation projects. On July 6, 2012, MAP-21 replaced SAFETEA-LU, which had been extended nine times since its expiration in 2009. The recent MAP-21 Conference Report expands the TIFIA program by authorizing a total of \$1.75 billion — \$750 million for FY 2013 and \$1 billion for FY 2014. The bill also increases the maximum share of project costs that can be funded with TIFIA financing from 33 percent to 49 percent, although given the magnitude of the entire ICS system capital costs, it is highly unlikely the project would secure a loan amount equal to the 49 percent of allowable project costs. It also allows TIFIA to be used to support a related set of projects and to set aside funding for projects in rural areas at more favorable terms, and requires the USDOT to submit a report summarizing the financial performance of projects that are receiving TIFIA assistance. The current State law for P3 (§43-1-1202) has no express provision against the use of TIFIA to support financing projects. This expansion to TIFIA could play a significant role in financing HST in Colorado.

Public-Private Partnerships

The Colorado General Assembly gave CDOT the authority to become involved in P3 financing for major projects. These are joint partnerships that can be formed between a private entity and CDOT to implement transportation projects funded mostly by private dollars. They are usually structured as “concessions” involving a concessionaire supported by financial, design-build, equipment, and O&M partners. The programs are typically bid for operation of the infrastructure for 20 or more years. Highway projects such as E-470 in Colorado are the most common examples.

Although not common in the U.S., transit projects are often procured under a P3 delivery system in most other parts of the world. There are various structures for P3 projects, some requiring the contractor or concessionaire to perform design-build-operate-maintain (DBOM) services at essentially a fixed cost; others include an element of private financing, usually a combination of debt and equity.

Considering both the cost of operation and capital, transit projects often do not operate with a profit, unlike highway projects funded by tolling. Thus, the

owner, in this case CDOT or State-enabled authority, has to pay the concessionaire a subsidy to make up the operating shortfall to cover both annualized capital, operations, and maintenance costs. This can be done in a number of different ways, based on the needs and preferences of the owner.

Common P3 approaches include:

- Fixed price/payment for the DBOM services (usually with escalation and penalties/deductions on the O&M portion).
- A combination of cash payments during the design-build phase, less than the actual cost of design-build, followed by at-risk revenues (such as fare box, advertising, etc.) plus subsidy payments that also usually have escalation and penalties/deductions.
- A combination of cash payments during the design-build phase, less than the actual cost of design-build, followed by availability payments made to the concessionaire based on meeting prescribed performance standards.

Implementation of a concession for HST would require some form of secured revenue stream such as federal funding, tolls, sales tax revenue, fare box revenues, or some combination of all of these sources. Private debt and equity could then be provided and retired based on the secured (subject to adequate performance) revenue stream from the owner as part of the monthly availability payment. This allows the public sector to leverage private capital over a 20- to 40-year period.

Another advantage of the P3 approach is that the private sector efficiencies driven by a profit motive have been found to result in a shortened delivery time, often at a reduced cost. The Denver Regional Transportation District, for example, realized a reduction in CAPEX of as much as \$300 million, or about 15 percent of the original estimated construction cost, for the Eagle P3 Commuter Rail project.

Section 9: References

- Colorado Department of Transportation (CDOT). 2008. *2035 Statewide Long Range Transportation Plan – Moving Colorado: Vision for the Future*. March.
- CDOT. 2011. *I-70 Mountain Corridor Programmatic Environmental Impact Statement*. June.
- CDOT. 2011. *North I 25 Environmental Impact Statement and Record of Decision*. December.
- CDOT. 2012. *State Freight and Passenger Rail Plan*. March.
- CDOT. 2013. *Advanced Guideway System Feasibility Study*. December.
- Denver Regional Council of Governments (DRCOG). 2011. *2035 Metro Vision Regional Transportation Plan Update*. February.
- Federal Railroad Administration (FRA). 2005. *Railroad Corridor Transportation Plans (RCTP): A Guidance Manual, Section II*. July.
- Leduc, Sylvain, and Daniel Wilson. 2012. *Highway Grants: Roads to Prosperity*, FRBSF Economic Newsletter. November 26.
- Pikes Peak Area Council of Governments (PPACG). 2012. *Moving Forward Update 2035 Regional Transportation Plan*. January.
- Pueblo Area Council of Governments (PACOG). 2011. *2035 Long Range Transportation Plan (LRTP) Amendment*. Adopted April.
- Rocky Mountain Rail Authority (RMRA). 2010. *High-Speed Rail Feasibility Study*. March.
- Trottenberg, Polly. 2011. Assistant Secretary for Transportation Policy, U.S. Department of Transportation. *Memorandum re: Treatment of the Economic Value of a Statistical Life in Departmental Analysis – 2011 Interim Adjustment*. July 29.
- U.S. Department of Transportation. 2010. *DOT FRA High Speed Intercity Passenger Rail Program*. Federal Register Notices, Volume 75, No. 126. July 1.
- Victoria Transportation Policy Institute. 2012. *Transportation Cost and Benefit Analysis II – Air Pollution Costs*. February 22.