

**EVALUATION OF COLORADO'S PRISON  
THERAPEUTIC COMMUNITY  
FOR SEX OFFENDERS:**

**A Report of Findings**

**JULY 2003**

**By**

Kerry Lowden  
Nicole Hetz  
Linda Harrison  
Diane Patrick  
Kim English  
Diane Pasini-Hill



Office of Research and Statistics  
Division of Criminal Justice  
700 Kipling Street, Suite 1000  
Denver, CO 80215  
303-239-4442  
<http://dcj.state.co.us/ors/>

Kerry Lowden, Project Manager  
Kim English, Research Director  
Raymond T. Slaughter, Director, Division of Criminal Justice  
C. Suzanne Mencer, Executive Director, Department of Public Safety

*Funded jointly by the United States Department of Justice, Office of Justice Programs (OJP) grant number 98-DD-BX-0018 and the Colorado Division of Criminal Justice Office of Drug Control and System Improvement Program (DCSIP) grants 98-DB1941 and 21-DB1962-2.*



## **ACKNOWLEDGEMENTS**

The research was made possible by grants from the United States Department of Justice, Office of Justice Programs, Bureau of Justice Assistance grant number 98-DD-BX-0018, and the Colorado Division of Criminal Justice Drug Control and System Improvement Program grants 98-DB1941 and 21-DB1962-2. We thank these entities for supporting this evaluation. We thank the DCSIP staff, in particular, for helping us with a multitude of grant management activities.

We would like to thank all those who assisted us in this research effort. We are especially grateful of the assistance of SOTMP program director Peggy Heil, CDCO researcher Sean Ahlmeyer, Arrowhead Correctional Center Warden Donice Neal, Community Corrections, Adult Parole, Community Corrections & Youthful Offender System Director Jeaneene Miller, and the staff of the SOTMP therapeutic community. These professionals spent many hours talking to us about the program, answering our interview questions, filling out our questionnaires, allowing us to observe groups, attend meetings and generally camp out at the TC for many months.

We are also grateful to Ernie Fernandez, RAM parole officers, and other individuals who were interviewed as part of this project including staff and administrators from the Department of Corrections and local community corrections facilities.

We were extremely fortunate to have Dr. Alan Listiak from the Minnesota Department of Corrections serve as a consultant on our study. Dr. Listiak's expertise in sex offender treatment and therapeutic communities greatly enhanced our understanding of the extensive amount of qualitative data we collected and analyzed for the process evaluation. He worked with researchers and TC managers at meetings and during conference calls to review and discussed our findings regarding service delivery and treatment integrity. Our concluding recommendations and the final research report were enhanced by our work with Dr. Listiak, and we are most grateful to him for the value he added to this study.

Finally, we would like to thank the inmates who participated in our focus groups and who graciously accepted us into their group treatment process. Without the cooperation of these men, we could not have conducted this research.

Pat Lounders, Paula Jensen, Mindy Miklos, Carol Poole and Ray Slaughter of the Division of Criminal Justice provided important support that led to the successful completion of this project. We thank you

While these contributions were invaluable to the research process, any errors or omissions remain the responsibility of the Office of Research and Statistics.



# TABLE OF CONTENTS

|     |   |
|-----|---|
| 9   | <b>Executive Summary</b>  |
| 23  | <b>Section One: Purpose of the Study</b>  |
| 24  | <b>Section Two: Introduction</b>  |
| 24  | History of Sex Offender Treatment at Colorado Department of Corrections                               |
| 25  | Changes in the Program Over Time  |
| 27  | SOTMP today   |
| 30  | Purpose of the Sex Offender Therapeutic Community in Colorado   |
| 34  | National Overview of Sex Offender Treatment in Prison   |
| 36  | <b>Section Three: Research Questions, Data Collection and Methods</b>                                 |
| 36  | Research Questions  |
| 36  | Data Collection and Methods: Question 1   |
| 40  | Data Collection and Methods: Question 2   |
| 46  | <b>Section Four: TC Standards and the Organization of the Findings</b>                                |
| 48  | <b>Section Five: Findings</b>   |
| 48  | Theoretical and Philosophical Basis   |
| 50  | Clinical Principles   |
| 64  | Administration  |
| 71  | Staffing  |
| 79  | Facility/Environment  |
| 83  | TC Program Elements   |
| 91  | TC Process  |
| 92  | Stages of Treatment   |
| 95  | Community TC and Clinical Management  |
| 97  | Intake Screening and Assessment   |
| 99  | Community-Based Aftercare   |
| 108 | Outcome Findings  |
| 128 | Limitations   |
| 131 | <b>Section Six: Recommendations</b>   |
| 135 | <b>Summary</b>  |
| 137 | <b>References</b>   |
|     | <b>Appendices</b>   |
| 145 | Appendix A: Therapeutic Community Sex Offender Treatment Monitoring Program Treatment Level Flowchart |
| 147 | Appendix B: Sex Offender Treatment Program Block Schedule   |
| 149 | Appendix C: Group Process Measure Form  |
| 153 | Appendix D: SOTMP Staff Interview Guide   |
| 157 | Appendix E: DOC Administration Interview Guide  |
| 159 | Appendix F: Community Correction Staff Interview Guide  |
| 161 | Appendix G: TC Therapist Questionnaire  |
| 167 | Appendix H: Data Collection Instrument  |
| 171 | Appendix I: TC Contract   |
| 183 | Appendix J: Personal Change Contract  |
| 191 | Appendix K: Rational Self-Analysis (RSA)  |
| 193 | Appendix L: Reasons for Termination   |
| 197 | Appendix M: SOTMP TC Polygraph Decisions Grid Form  |
| 203 | Appendix N: Staff Orientation Checklist   |
| 207 | Appendix O: Cardinal, Basic and House Rules   |

|            |   |
|------------|---|
| <b>209</b> | Appendix P: Assessment Descriptions   |
| <b>213</b> | Appendix Q: Conviction Crimes by Treatment Groups                                   |
| <b>215</b> | Appendix R: Recidivism for Sex Offenders Either Discharged from<br>Prison or Parole |

### **Figures**

|            |  |
|------------|--|
| <b>28</b>  | Figure 1: How Offenders are Integrated into the Community  |
| <b>44</b>  | Figure 2: Outcome Study Groups   |
| <b>118</b> | Figure 3: The Proportion of Cases Not Rearrested for a New Crime by<br>Treatment Groups: Survival Analysis |

### **Tables**

|            |   |
|------------|---|
| <b>32</b>  | Table 1: Utilizing Therapeutic Communities in Advanced Sex Offender<br>Treatment              |
| <b>38</b>  | Table 2. Summary of Meetings Attended by Research Staff                                       |
| <b>40</b>  | Table 3. Summary of Other Data Collection Activities  |
| <b>43</b>  | Table 4: Time at Risk from Discharge to Community   |
| <b>57</b>  | Table 5: Groups Observed  |
| <b>93</b>  | Table 6: 2003 TC Therapeutic Community Treatment Levels                                       |
| <b>108</b> | Table 7: Study Sample Groups  |
| <b>109</b> | Table 8: Ethnicity  |
| <b>109</b> | Table 9: Marital Status   |
| <b>110</b> | Table 10: Study Group Comparison: Age and Dependents  |
| <b>110</b> | Table 11: Average Prior Felonies, Prior Incarcerations and Length of<br>Current Incarceration |
| <b>111</b> | Table 12: Sex Crime Conviction Charges  |
| <b>111</b> | Table 13: Prior Incarcerations  |
| <b>112</b> | Table 14: Released to Parole  |
| <b>112</b> | Table 15: Sexual Violence Code  |
| <b>113</b> | Table 16: Parole Outcomes by Study Group  |
| <b>114</b> | Table 17: Outcome Information on Sex Offenders Discharged Directly from<br>Prison             |
| <b>116</b> | Table 18: Outcome Information on Sex Offenders Discharged from Parole                         |
| <b>119</b> | Table 19: Time to New Arrest  |
| <b>120</b> | Table 20: Select Demographics by New Arrest within First Year of Release                      |
| <b>120</b> | Table 21: Recidivism Status by Race/Ethnicity   |
| <b>121</b> | Table 22: Recidivism Status by Marital Status   |
| <b>122</b> | Table 23: Criminal History by New Arrest within First Year of Release                         |
| <b>122</b> | Table 24: Recidivism Status by Prior Incarcerations   |
| <b>123</b> | Table 25: Recidivism Status by Sexual Violence Code   |
| <b>123</b> | Table 26: Recidivism Status by Release Type   |
| <b>125</b> | Table 27: Factors that Contribute to Influence During the First 12 Months of<br>Release       |
| <b>126</b> | Table 28: Characteristics Affecting Outcome: Cox Proportional Hazards<br>Regression Model     |
| <b>127</b> | Table 29: New Arrests by Time in TC Treatment   |
| <b>129</b> | Table 30: Availability of Data from Specific Assessment Tools                                 |







## EXECUTIVE SUMMARY

The Colorado Division of Criminal Justice (DCJ), Office of Research and Statistics (ORS), conducted an evaluation of the sex offenders therapeutic community (TC) at the Colorado Department of Corrections (CDOC). This evaluation focused on two primary questions:

- (1) Are the components of CDOC's sex offender therapeutic community grounded in theory and best practice, and
- (2) Are outcomes for sex offenders who receive Sex Offender Treatment and Monitoring Program (SOTMP) services better than outcomes for sex offenders who do not receive these services?

To evaluate the TC, we reviewed the literature on best practices for therapeutic communities and sex offender treatment, including the in-prison standards developed by Therapeutic Communities of America (TCA). Researchers attended 25 TC meetings with staff or the community, observed 67 treatment groups sessions, conducted 18 in-depth interviews and 7 focus groups, reviewed 578 treatment files, and collected information from staff questionnaires to obtain information necessary to answer the first question.

To address the second question, outcome data were extracted for adult, male, English-speaking sex offenders who discharged their prison sentences between April 1, 1993 and July 30, 2002. The 1993 date marks the introduction of the Sex Offender Therapeutic Community at the Colorado Department of Corrections. Inmates were identified as sex offender if they were designated S3, S4 or S5 on the Colorado Department of Corrections' Sexual Violence Scale (S-Code). Outcome data included new arrests, court filings and prison incarcerations; each of these outcomes was studied separately.

The findings to the first research question are presented below and are organized according to the treatment components required by the Therapeutic Communities of America's *Revised TCA Standards for TCs in Correctional Settings (1999)*, published by the Office of National Drug Control Policy. The outcome findings pertaining to the second research question follow the discussion of the treatment program. This summary concludes with recommendations based on the research findings.

## RESEARCH FINDINGS: PROGRAM INTEGRITY

### Component 1. Theoretical and Philosophical Basis

**FINDING:** *The SOTMP TC has documented its philosophy and the theoretical underpinnings of its treatment approach in the “SOTMP Program Manual and its Resource Guide.” The program is indeed grounded in theory and research.*

### Component 2. Clinical Principles

#### (1) Structured Community Living and “24/7”

**FINDING:** *In some ways the TC operates as a 24/7 milieu and in others it does not. Staff disagreed as to whether the community operated 24/7. Most thought that correctional staff involvement was fundamental to the operation of a 24/7 program. These staff believed training, integrating and getting “buy-in” from correctional staff and prison administrators was necessary on an ongoing basis. Inmates generally felt that the community operated 24 hours a day, seven days a week, with the inmates providing treatment and support to each other in many ways outside the group therapy environment. However, some inmates revealed that they were not working the program.*

#### (2) Community as the Method of Intervention

**FINDING:** *The structure of the TC is designed to facilitate community living and has been appropriately modified to address the special issues of sex offenders. Daily staff meetings enhance communication among therapists and provide opportunities for follow ups and updates on offenders. TC inmates are expected to support the treatment efforts of their brothers by using TC concepts including the pull-up system (pull-ups represent a method for holding each other accountable). While the pull-up system is not perfect, almost all inmates we spoke with agreed that it works and is essential to treatment.*

#### (3) Group Therapy and the Clinical Principal of Community as the Primary Agent of Change

##### (a) Group Therapy

**FINDING:** *A multifaceted approach to treatment is accomplished by providing a variety of group treatment interventions. Group sessions are the primary means of providing treatment in the TC. This is a modification from traditional TCs where the experiences of living and interacting with others in the TC are the primary intervention. “The community is the method” is a premise of traditional TCs. Required treatment content is documented in the treatment manual.*

(b) *Group Participation*

**FINDING:** Most groups had high levels of participation, and offenders were consistently held responsible for their thinking errors and inappropriate behaviors. Treatment activities emphasized “doing, rather than getting” therapy, and inmate participation played a major role in providing treatment through the group process. In most cases, participants appeared to understand the concepts related to sex offending behaviors, as indicated by the quality of feedback and input offered when confronting each other. The role of group treatment in providing support is evident.

(c) *The Role of the Therapist in Groups*

**FINDING:** The majority of the time, TC therapists modeled pro-social attitudes and behaviors, and confrontations were carried out firmly but respectfully. Most of the TC therapists were very skilled at group facilitation; however, some variation was observed that suggests the need for additional training and clinical supervision. Generally, therapists made good efforts to respond to offender questions and provide clarification, but some opportunities to provide inmates information were missed. In a few group sessions, the effort by the therapist to present material to the group appeared to outweigh the importance of inmates learning the concepts and, in a few group sessions, therapists lectured inmates, and this appeared to negatively affect the group process.

### **Component 3. Administration**

(1) *General Administrative Support*

**FINDING:** Administrators and staff generally agreed that the goals and philosophy of the sex offender therapeutic community integrate with the philosophy of the Colorado Department of Corrections. However, the program is not strongly supported by correctional administrators as evidenced by the need for the program to direct scarce resources away from services and toward providing continual justification for the SOTMP. Further, the conflict between addressing individual offender needs and the correctional approach of treating all inmates equally may undermine the program. Finally, the facility was established as a work camp, and the focus on work often supercedes treatment and offenders miss group sessions due to work activities.

(2) *Adequate Funding*

**FINDING:** The SOTMP is minimally staffed. Current funding for the SOTMP program (including the therapeutic community) indicates that the annual cost of this program is \$2,613,241, representing approximately .049 percent of the Colorado Department of Corrections general fund budget request of \$532,753,788 for FY2003-04. Administrators reported concerns regarding the costs of the TC and, in the past few years, the SOTMP has lost ten therapist positions (approximately one-fourth of the staff), the program researcher, and training and contract funds.

### (3) Clear Policies

**FINDING:** SOTMP staff policies are well documented and available to TC staff. Admission, suspension and termination policies for offenders are outlined in each inmate's treatment contract, along with rules for participation and moving through the program. A sanction grid has been developed that standardizes consequences for undesirable behaviors and proposes rewards for progress.

### (4) Clear Positions on Confidentiality

**FINDING:** The TC operates on a policy of "no secrets" among TC members and staff regarding treatment issues, although confidentiality outside this realm is maintained according to typical therapeutic confidentiality standards. This position is specified for offenders in the treatment contract. This is considered best practice in the treatment of sex offenders.

### (5) Treatment Plans

**FINDING:** The development and use of treatment plans as a working document that guides interventions and measures progress toward goals appears to be underutilized by TC staff.

### (6) Quality Assurance

**FINDING:** There is no formalized, long-term systematic procedure to observe groups or review files. There is no audit or quality assurance process in place. Over the years, plans were developed to implement some form of quality control but this effort was never funded.

## **Component 4. Staffing**

### (1) Staff Selection and Qualifications

**FINDING:** SOTMP managers engage in a careful selection and hiring process, and TC staff are qualified and committed to the program. The TC therapists have had prior professional experience working with sex offenders and other special populations. All TC therapists have prior experience working as Phase 1 therapists. Many of the therapists have experience working with sexual assault victims. However, hiring freezes, lengthy state hiring processes, and an inability to meet customary salary requirements, combined with the type of work (treating sex offenders in prison) combine to make hiring qualified staff a difficult process.

### (2) Training

**FINDING:** TC staff receive the following training: an initial 40 hour training provided by the SOTMP administrators and staff; academic training; conferences, in-service seminars and other training as available. Staff also receive on-the-job training and supervision while working at Phase I and later, at the TC. Additionally, monthly SOTMP staff meetings often include training. Orientation training, unfortunately, does

not always occur in a timely fashion because it is inefficient to conduct a 40-hour training for one or two new staff. During interviews, staff suggested several topics for additional training, including group facilitation skills training. Our research suggests that TC-specific training that focuses on community living is also needed. Professionals who work with sex offenders require ongoing training to keep up with changes in a field that is quickly evolving, to keep their skills sharp, and to battle the burnout that comes with working with a violent and manipulative population. This need for ongoing training does not appear to be well understood by DOC administrators.

### (3) Supervision

**FINDING:** Some therapists noted that they received supervision on a regular basis while others would like scheduled or increased supervision. Researchers observed clinical supervision occurring in the daily staff meetings.

### (4) Training and Integration of Non-Therapeutic Staff

**FINDING:** Despite the importance of the role of correctional officers in facilitating the 24-7 treatment milieu, correctional staff was provided limited training and orientation to the TC program. Staff perceived that individual officers vary in their level of “buy in” to the program. The inconsistency in “buy in” from correctional staff may negatively impact the program by creating barriers to or missed opportunities to provide treatment in the milieu and the workplace.

## **Component 5. Facility/Environment**

### (1) Housing/Location

**FINDING:** During the time of the on-site observations by researchers, a hiring freeze reduced the number of therapists available to work in the TC and the population of sex offenders was capped until sufficient services could be delivered. Empty TC beds were filled with inmates from the general population. The Arrowhead TC staff agreed that housing the general population within the TC created numerous problems. Staff noted that the general population (GP) had a negative influence on the unit, and that these offenders “contaminate” the TC program because they are invested in the inmate code of conduct, which is antithetical to treatment. The facility is also shared with offenders participating in the TC for substance abuse. Mixing the drug and alcohol population with sex offenders seems to have both positive and negative effects on the treatment environment.

### (2) Facility Space

**FINDING:** Group meeting space was sometimes inadequate and seems to negatively impact service delivery. Privacy is at a minimum in some of the treatment settings. Interruptions, distractions and noise sometimes made it difficult to focus and hear the group discussions.

### (3) Safety

**FINDING:** For some inmates, sharing an environment with the general population inhibited their willingness to be open and honest in certain situations. Some said they were fearful of being labeled a “snitch.” Other inmates did not seem to share this concern.

## **Component 6. TC Program Elements**

### (1) Wing Meetings and House Meetings

**FINDING:** Daily meetings occurred where inmates shared news and events; one of the purposes of these meetings was to provide inspiration and support to community members. Weekly meetings, run by inmates, served to introduce new members to the community as well as to update each other on changes in the group schedule and other important information.

### (2) Rituals and Rites of Passage

**FINDING:** The TC incorporated ways for an offender to receive positive feedback but this transpired primarily during group treatment sessions rather than within the larger community. Recognizing individual progress and marking important occasions occurred through “announcements” made at the beginning of groups in which the offender would share some positive experience, like passing a polygraph exam. While this provides offenders with a forum for receiving public, positive feedback, “announcements” made at daily meetings might also be considered as an avenue to honor progress and other positive events.

### (3) Work

**FINDING:** The TC includes a work program that allows members to apply what they learn during group to their work setting while acquiring and building valuable skills at the same time. There are times, however, that the offender’s job duties and/or schedules sometimes have priority over the delivery of treatment or the attendance of groups. Also, when work supervisors are not integrated into the TC program, important intervention opportunities are missed.

### (4) Group Therapy (Process Issues)

**FINDING:** In accordance with both the literature and Colorado Sex Offender Management Board Standards and Guidelines, most group sessions were appropriate in size and co-facilitated by a man and a woman therapist. Groups in the block schedule were occasionally cancelled. Several staff members told us that inmates are not always informed of these changes in the schedule. Of the 67 groups we observed that were scheduled for two hours or more, the average duration of groups was 86 minutes. Almost all of the groups we observed started late, ended early, or both.

## (5) Other Treatment Elements

### (a) Addressing Denial

**FINDING:** Offenders appeared to make progress toward reducing the use of denial and minimization as defense mechanisms. Over time, we observed offenders admitting more victims and/or behaviors during group sessions. Offenders appropriately confronted each other on denial behaviors. Working through denial was clearly an important component in the therapeutic process.

### (b) Polygraphs

**FINDING:** Polygraphs are used throughout an offender's stay in the TC to verify the self-reported sexual history information and to determine participation in high-risk or inappropriate behaviors. A sanctions grid is used to consistently apply positive and negative sanctions related to polygraph exam outcomes.

## **Component 7. The TC Process**

**FINDING:** Treatment is primarily delivered through the group session process. Senior group members assisted new group members by teaching them about group sessions, group expectations, modeling behaviors and participation, and providing them with other information needed for successful functioning in the group. Some inmates become "big brothers" to newer TC members. This process provides an opportunity for inmates to learn from each other and to practice interpersonal skills. Offenders in focus groups reported seeking support from other TC members on the unit when they are struggling with something.

## **Component 8. Stages of Treatment**

**FINDING:** The program design is consistent with TCA standards and recommendations in the TC literature. There are five clearly defined, successive levels of treatment. Staff, administration, and inmates, however, expressed concern about the difficulty offenders have progressing through the treatment stages. In response to these concerns, TC managers recently modified some of the requirements of each stage to better facilitate and reward progress in treatment.

## **Component 9. Community TC and Clinical Management**

### (1) Treatment Contracts

**FINDING:** The SOTMP Therapeutic Community's treatment contracts were consistent with the 1999 TCA Standards and outline responsibilities of the offender and the therapist.

## (2) Termination and Suspension

**FINDING:** Despite perceptions from some inmates that termination from the program may be unfair, the policy on terminations and suspension is clearly stated in the treatment contract. Staff also informed us that offenders are given numerous opportunities to succeed before they are terminated from the program except in the case of cardinal rule violations when termination is immediate.

## **Component 10. Intake Screening and Assessment**

### (1) Sex Offense Specific Evaluation

**FINDING:** An array of assessments and questionnaires were used to evaluate offender needs. However, because the evaluation often was not conducted when the offender began treatment in the TC, it was not regularly used to guide the treatment plan or inform the way the individual therapist works with the client.

### (2) Risk Assessments

**FINDING:** Although the treatment manual states that offender risk should be evaluated using the actuarial scale developed by DCJ's Office of Research and Statistics, the risk scale is not in the treatment file nor was it used at the time of the study.

## **Component 11. Community-Based Aftercare: Parole and Community Corrections**

### (1) Aftercare – Parole

**FINDING:** Parole officers unanimously agreed that the TC improved communications between parole staff and prison staff. Officers reported that the information they received from treatment providers was valuable in assessing risk and managing the offender. According to the officers, transition from prison to parole is more difficult when sex offenders have not received treatment. Parole officers reported spending considerable time orienting offenders who have not participated in prison treatment to the supervision rules that apply once they are released on parole; many of the new rules did not apply to them in prison (such as prohibited contact with children). The RAM team caseload increased in size in recent years due to budget cuts and this results in a decrease in supervision resources available to each case.

### (2) Aftercare - Community Corrections

**FINDING:** Few TC offenders receive community-based aftercare for a number of reasons. First, few placements are available to sex offenders because local community corrections boards, which have the authority to accept and reject individual clients, are reluctant to accept these clients citing community safety concerns, liability issues, the cost of treatment services, and concerns about potential negative media attention. Offenders reported that they often fail to meet a key criterion to enter community corrections from prison: passing a sex history



polygraph examination. Yet TC staff reported that passing the polygraph is not holding the clients back but rather the inmates' inability or unwillingness to identify a community person for support from among those who know the offenders' complete sexual abuse history. Although few sex offenders have been placed in community corrections from the TC, halfway house program staff perceived important benefits to therapeutic community treatment according to interview data. We spoke with three offenders who were recently released to a community corrections program, and they described many challenges to community life including coping in an environment with less structure, impediments to obtaining jobs, and difficulties living with the general population (non-sex offenders). However, each of them described specific tools and skills they learned at the TC that they used to help with their transition from prison, and they discussed the value of being released simultaneously so they can offer and receive support together. For these offenders, release to community corrections was a better option than discharging directly into the community because, while it did not provide as much structure as the TC, it provided them much more structure than if they were on their own. At this writing (six months post-community placement), they remain successful participants in the community corrections program.

## **OUTCOME FINDINGS: OFFICIALLY RECORDED RECIDIVISM**

**FINDING:** Participation in treatment is significantly associated with success on parole. We analyzed parole completion/revocation rates for 1,585 sex offenders released to parole between April 1, 1993 and July 30, 2002. Nearly half (47.7 percent) of the offenders in the no treatment group were revoked back to prison. This revocation rate for offenders who did not participate in treatment is three times higher than the group that participated in the TC, and it is 50% higher compared to the group that participated in Phase 1 treatment.

**FINDING:** Participation in treatment significantly reduces the rearrest rate of offenders. The rearrest rate for violent crimes in the first year following release for the no treatment group is more than double the rate of violent rearrest among sex offenders who participated in treatment. Significant differences in rearrest rates across the groups remained for at least 7.5 years.

**FINDING:** The length of time an offender participates in treatment is significantly related to positive outcomes after release from prison. This finding is consistent with research in the area of substance abuse: The greater time an offender spends in treatment (including cumulative multiple treatment episodes), the greater the likelihood that the offender will succeed following treatment. For each additional month spent in the TC, inmates increase their chances of success upon release by one percent (12 percent per year).

**FINDING:** The long term outcome of offenders who were first placed on parole were significantly better than the group that was discharged from prison without parole, reflecting the value of parole supervision for community safety.

## RECOMMENDATIONS

Based on the information collected and analyzed for this study, we make the following recommendations to improve the SOTMP therapeutic community program at the Arrowhead Correctional Center:

### Enhance the Therapeutic Milieu

- Efforts to increase the use of community living as a major intervention method should be prioritized by TC managers. Considerable expertise exists within the TC management to facilitate the use of this powerful method.
- The TC is unlikely to acquire the resources necessary to staff the facility with therapists 24 hours a day, seven days a week. However, increased availability of therapists for one-on-one exchanges with inmates will likely enhance service delivery and offender responsiveness to the program. The TC staff offices are outside the facility perimeter and so it requires a special effort to ensure that therapists are sometimes available to inmates during times other than group sessions. Recent program modifications reflect that the TC managers are developing a requirement for therapists to spend time every week in the living unit. This time is available for individual discussions, “drop – ins” or just touching base with inmates.
- We recommend that once the program is fully staffed again, the TC implements additional changes to facilitate inmate-therapist contact outside of group sessions. We recommend that therapist schedules be made flexible to include evening work hours to facilitate better use of the community setting and reinforce the program philosophy and treatment content in inmates apart from group hours.
- At some point the DOC administration should consider making office and group room space in the living unit to increase formal and informal interaction with inmates and to support the therapeutic milieu. Currently, therapists sit in a corner of the day hall, seeing people as they line up to talk. No privacy exists during these exchanges.
- Training programs and all-staff meetings should include correctional officers, case managers, and DOC work staff from the kitchen and greenhouse to maximize the intervention potential of the TC. Non-treatment staff should observe group sessions and participate in house meetings as their shifts allow. TC staff and DOC administrators should entertain other creative ideas to integrate correctional officers into the TC environment. For instance, perhaps a correctional officer could be trained to co-facilitate a psycho-educational group.
- Cross-training should occur on an annual basis to make sure that all professionals involved in the TC program and facility management understand each others’ needs and expectations for running a safe, therapeutic environment.

### Recognize Inmate Progress in the Program

- Within the restrictions required by a prison environment, TC staff should develop and implement more regular activities and rituals to celebrate positive change and enhance the acknowledgment of inmate progress. These rituals may also provide important motivation for inmates to continue working the program.
- Staff and offenders recognized that forward progress through the five treatment levels in the TC was difficult for inmates to achieve. The lack of movement through the program also had negative impacts for TC participants including those who returned to the general population. TC inmates were discouraged to see each other stay at the same treatment level for long periods of time; many expressed a sense of hopelessness about the possibility of their own progression. Indeed, it is rare for sex offenders to be given a community placement or to receive parole. Therefore, we recommend TC staff continue and expand their recent efforts to redefine and modify the requirements of the treatment levels in the TC, community corrections and parole to provide more opportunities for successful movement through program phases. (Note that offenders are eligible to apply for community placement at the second treatment level.)

### Education/Training Needs

- Although the TC has made many efforts to educate DOC administrators about the difficulty moving inmates through the program, more education needs to be provided. Administrators need information on the following topics:
  - the most difficult issues associated with treating sex offenders, including but not limited to:
    - individual accountability and responsibility are critical program components and require core changes;
    - the difficulties inherent in the change process, including that an individual's treatment progress is seldom linear and consistent in pace;
    - program termination rates are high when individual accountability is a treatment priority,
    - failure to hold individuals accountable will undermine the entire program;
    - the length of time required to make entire lifestyle changes.
  - The unavoidable and natural impact of the job on those who work with this population on a daily basis (including correctional staff, work supervisors, and case managers) and the corresponding need for training.
  - The impact on the program of the competing interests of group and work time.

- The relapse model (meaning failure is expected).
  - The value of more (not less) time in treatment.
  - The “no cure” nature of sex offending.
  - the life long need for treatment and management.
- TC staff would benefit from training specifically targeting group facilitation and facilitator roles for both psycho-educational and process groups and how to include offender participation in both formats. As mentioned earlier, cross training not only for TC clinical staff, but for DOC staff as well, would enhance the therapeutic impact of the 24/7 milieu setting.

### Enhance Some of the Treatment Components

- Case-specific treatment plans should be developed with each offender so that the achievement of therapeutic goals is clearly specified and given expected dates of completion (which will vary across clients). Treatment expectations should be measurable and understood by both the therapist and the program participant. These plans should be comprehensive and individualized. Eliciting offender input, even concerning minor details of treatment, can significantly increase compliance and investment on the part of the client (Meichenbaum and Turk, 1987). Specific goals can structure and guide the individual’s performance, focusing attention and involvement on progressing on their specific issues rather than simply the five treatment phases. Individual treatment contacts should address the plan, and regular feedback from the case manager should be incorporated into progress reports. The treatment plan should be a dynamic document that is updated with the offender on an ongoing basis.
- Treatment plans should include strategies to transition the offender to the community.
- Given the disproportionate rearrest rate of non-Anglos, the program should research and then implement culturally appropriate methods of interventions. Since this finding is consistent with outcomes in the drug and alcohol field, and so that literature should be reviewed.

### Process Terminations with Offenders

- Focus group data revealed that inmates who were terminated from the TC had a powerful affect on the remaining members. For some TC participants, the feelings of loss (along with concern that it could happen to them next) appeared to be expressed as anger at what was perceived to be the unjust use of staff power. Because waivers of confidentiality terminate when the case is terminated, TC staff are not free to discuss termination details. To address this issue, the treatment contract was recently modified to permit TC staff to discuss termination reasons with the community when appropriate. Efforts should be made to track this change to determine if it is accomplishing its intent: to address the feelings of failure that “brothers” expressed during focus groups when someone terminates from the program.

### Enhance the Group Process

- If at all possible, conduct meetings in private spaces and not in high activity areas.
- If inevitable schedule changes occur, inform inmates of these adjustments as soon as possible.
- Ensure therapists make better efforts to start and end groups on time or revise the block schedule to more accurately reflect treatment time.

### Increase Program Resources and Quality Assurance Measures

- We recommend that more resources be dedicated to developing sex offense specific evaluations so they can be completed upon intake or shortly thereafter so these can be incorporated into and guide the treatment plan. The sex offender risk assessment scale developed by the ORS on behalf of the Sex Offender Management Board should be one part of the assessment and evaluation process.
- The program has made remarkable efforts to collect and analyze data on the program since the hiring of a researcher in 1996. However, many important data elements remain unreliable (such as reason for program termination and days in Phase I treatment). We recommend that program administrators and staff work with researchers from this study to identify data elements and methods of collection that would be useful in future program evaluations.
- Enhance the ability to implement quality assurance procedures. Supervisors should observe service delivery during group sessions, ensure proper completion of the sanctions grid, review treatment plans, and review community referral documents, but due to staff shortages, only basic services are provided by the program. We recognize that resources are required to ensure program integrity; we recommend developing a quality assurance position for the program when resources become available.
- Many staff would like increased supervision. Scheduled administrative and clinical supervision times, including group observation by supervisors, will improve programming and support program staff.
- Given the increasing numbers of sex offenders currently in prison, and the positive outcomes of those receiving SOTMP services revealed in this study, the CDOC should make expanding treatment resources a priority even in this time of critical budget shortfalls. Public safety requires increasing treatment resources to maximize the number of sex offenders receiving treatment in the CDOC. The social cost of victimization far outweighs the cost of sex offender treatment. Criminal justice policy makers statewide should work together to support the expansion of this program.

## **SUMMARY**

The program evaluation findings reported here reflect the challenges of service delivery in a correctional environment. The SOTMP offers a comprehensive, intense program for Phase 1 offenders: A minimum of six months of psycho-educational group sessions with meetings four times per week. Only those who complete Phase 1 are considered for placement in the TC which offers a living/working environment focused on treatment. One year in the TC should be considered the minimum length of stay with the understanding that each additional month reduces by one percent the probability for rearrest. The resources devoted to this effort, combined with the offenders' efforts to change, appear to profoundly improve public safety as measured by officially recorded recidivism. In the face of budget shortfalls, this program should be protected from any further reduction in staff resources and should be a budget priority when state budgets recover from the current economic downturn.

The outcome findings presented here reflect a time when the SOTMP was fully funded and fully staffed. The recent budget cuts sustained by the program may diminish the delivery of services. We would expect treatment outcomes to diminish correspondingly.

The CDOC is to be applauded for institutionalizing a program that targets a most dangerous offender population for intensive offense-specific treatment delivered according to best practices. The citizens of the state of Colorado are safer because of the effectiveness of the SOTMP.

## SECTION ONE: PURPOSE OF THE STUDY

The Therapeutic Community (TC) within the Colorado Department of Corrections, created in 1993, is based on the sex offender and substance abuse literature as a promising method of creating lasting change among its residents. As of the beginning of 2000, the population of identified incarcerated sex offenders amounted to approximately 24 percent of the state's adult incarcerated population.<sup>1</sup> Without specialized treatment, the probability is high that many of these offenders will continue to harm victims after release from prison.

Because of the importance of assessing meaningful and successful interventions for this dangerous population, the Colorado Division of Criminal Justice, Office of Research and Statistics (ORS), conducted an evaluation of the TC. The results of this evaluation are presented here. We examined whether the fundamental components of the TC are firmly grounded in theory and best practices, and if sex offenders who receive TC services were less likely to be rearrested than sex offenders who do not receive services. The information presented here should serve as a guide to others interested in developing prison-based programs for sex offenders.

The Colorado Division of Criminal Justice, Office of Research and Statistics conducted this research under the auspices of the United States Department of Justice, Office of Justice Programs Bureau of Justice Assistance grant number 98-DD-BX-0018, and the Colorado Division of Criminal Justice Office of Drug Control and System Improvement Program grants 98-DB1941 and 21-DB1962-2. Findings presented in this report are those of the ORS and not the funding agencies.

---

<sup>1</sup> The total adult inmate jurisdictional population was 16,359 as of December 31, 2000 (CDOC, Monthly Project Status Report, May 12, 2003).  $4000/16359=24$  percent.

## SECTION TWO: INTRODUCTION

### A. History of Sex Offender Treatment at Colorado Department of Corrections (CDOC)

The Colorado Department of Corrections (CDOC) established the Sex Offender Treatment Program (SOTP)--later called the Sex Offender Treatment and Monitoring Program (SOTMP)--in 1985. The SOTP was designed to provide specialized treatment, monitoring and accountability for sex offenders. Originally the SOTP was a component of general mental health services. One therapist was assigned to the program. Over the next few years an additional therapist was assigned full time to treat sex offenders. These therapists, who were often assisted by general mental health staff, facilitated treatment group sessions.

According to the CDOC Sex Offender Treatment Program Plan, dated July 1, 1985. The program was “designed with the understanding that most sex offenses are the sexual

*The program was “designed with the understanding that most sex offenses are the sexual expression of aggression, not the aggressive expression of sexuality.”*

expression of aggression, not the aggressive expression of sexuality” and components of the program were built to address the dynamics involved in sex offenses as understood at the time. The program originally consisted of three phases of intervention. Phase I was the basic group for sex offenders and subject matter consisted of didactic groups covering the etiology of sex crimes, sex education, sex roles, social skills, and stress management. Participation in Phase I required that offenders admit to the crime, admit to having a problem, agree to the conditions of the group, and have medium- or minimum-security designation. Phase I was offered at Shadow Mountain Correctional Facility (SMCF), Fremont

Correctional Facility (FCF), and Colorado Territorial Correctional Facility (CTCF). By May of 1985, 42 inmates completed the Phase I program.<sup>2</sup>

Phase II was the Advanced Group for sex offenders offered at FCF, CTCF, and San Carlos Correctional Facility (SCC), according to the 1985 treatment program plan. The groups in Phase II focused on cognitive restructuring and behavior while encouraging incorporation of the concepts presented in Phase I. Phase II was designed to focus on current individual behavior and thinking patterns with a focus on building interpersonal skills. Requirements for Phase II included completing Phase I, agreeing to the conditions of Phase II, and having medium- or minimum-security designation.

Phase III in these early days was called Pre-release Preparation, and inmates were housed in one living unit for the purpose of focusing on each inmate’s individual deficits and needs. According to the 1985 Sex Offender Treatment Program Plan, components of Phase III included intensive social skills training, family life education, training on community resources, family therapy, individual therapy, employment searches, and planning for treatment and support when released. Phase III requirements included having less than one year to parole eligibility, successfully completing Phase II, agreeing to the conditions of recommended treatment, and having a medium- or minimum-security designation.

---

<sup>2</sup> Information obtained from the Colorado Department of Corrections (CDOC) Sex Offender Treatment Program Plan, dated July 1, 1985.



## B. Changes in the Program Over Time

According to interview data with TC administrators, the sex offender program has changed considerably since the mid-1980s, reflecting advances in the field of treatment and changes in the correctional environment. In the late 1980s, several studies were published that reflected the success of substance abuse treatment, particularly when it was combined with criminal justice system consequences for treatment non-compliance. In particular, studies published in professional research journals were finding successful outcomes for clients that participated in intense, residential-based treatment programs for substance abusers (these studies are discussed later in this report). Mental health administrators at the Colorado Department of Corrections were interested in improving prison treatment for both sex offenders and offenders with histories of substance abuse problems. They began to explore ways to develop and implement a therapeutic community (TC) for drug and alcohol offenders and also for sex offenders, since treatment interventions for sex offenders were largely based on practices that were well researched in the drug and alcohol field. To this end, CDOC sex offender supervisors visited four state prison systems that operated therapeutic communities for sex offenders<sup>3</sup> to learn more about how this idea could be implemented in Colorado.

*The sex offender program has changed significantly since the mid-1980s, reflecting advances in the field of treatment and changes in the correctional environment.*

*CDOC sex offender supervisors visited four state prison systems that operated therapeutic communities for sex offenders to learn more about how this idea could be implemented in Colorado.*

Meanwhile, important changes in the overall correctional environment also affected the program. In the early 1990s, criminal justice policy experts in Colorado began to discuss the value of developing a multi-disciplinary, multi-agency board of professionals who would develop standards for the treatment of sex offenders. A similar multi-disciplinary group had developed standards for the treatment of offenders with substance abuse problems (C.R.S. Article 11.7), and there was interest in replicating this activity for the treatment of convicted sex offenders. In 1992, based on a bill developed with the participation of private treatment providers, the victim advocate community, and criminal justice experts, the General Assembly created the Colorado Sex Offender Management Board (SOMB)<sup>4</sup> to standardize the assessment, evaluation, treatment, and behavioral monitoring of convicted sex offenders at each stage of the criminal justice system.<sup>5</sup> The following year, the General Assembly mandated an expansion of sex offender treatment services in the Department of Corrections, including parole:<sup>6</sup>

*In 1992, based on a bill developed with the participation of private treatment providers, the victim advocate community, and criminal justice experts, the General Assembly created the Colorado Sex Offender Management Board (SOMB) to standardize the assessment, evaluation, treatment, and behavioral monitoring of convicted sex offenders at each stage of the criminal justice system.*

<sup>3</sup> Visits were made to prison programs in Oregon, Minnesota, Nebraska, and Missouri. In 2000, according to a study sponsored by the Colorado DOC, there were 20 states in the U.S. that had a form of prison TC/intensive therapy program including Alaska, Arkansas, Colorado, Maine, Massachusetts, Minnesota, Montana, Nebraska, New Hampshire, New Jersey, New York, North Carolina, Oklahoma, Pennsylvania, Tennessee, Texas, Vermont, Virginia (residential), West Virginia, and Wisconsin. See the survey posted at <http://www.doc.state.co.us/programs.htm> for more information.

<sup>4</sup> Colorado Revised Statutes 16-11.7-101 to 107. In the legislation the SOMB was the Sex Offender Treatment Board. The name was changed later to more accurately reflect the duties of the Board.

<sup>5</sup> In 1996, the SOMB published its first set of standards and guidelines for working with sex offenders.

*Each sex offender sentenced by the court for an offense committed on or after January 1, 1994, shall be required as part of any sentence to probation, community corrections, or incarceration, to undergo treatment to the extent appropriate to each offender.*

(1) Each sex offender sentenced by the court for an offense committed on or after January 1, 1994, shall be required as part of any sentence to probation, community corrections, or incarceration, to undergo treatment to the extent appropriate to such offender based upon the recommendations of the evaluation and identification made pursuant to [the SOMB guidelines]... Any treatment or monitoring should be at a facility or with a person certified or approved by the board and at such offender's own expense, based upon such offender's ability to pay for such treatment.

(2) Each sex offender placed on parole by the state board of parole on or after January 1, 1994 shall be required, as a condition of such parole, to undergo treatment to the extent appropriate... (C.R.S. 16- 11.7-105).

In 1993, a TC at Arrowhead Correctional Center was opened to serve drug and alcohol inmates, and a modified TC was opened for sex offenders. Forty-eight beds were allocated for sex offenders, and this was expanded to 96 beds in 1996 when additional funds were obtained from the General Assembly. In 1996, Sex Offender Treatment and

*In 1993, a TC at Arrowhead Correctional Center was opened to serve drug and alcohol inmates, and a modified TC was opened for sex offenders.*

Monitoring Program (SOTMP) administrators successfully applied for a grant to integrate the use of the polygraph with sex offenders who were participating in treatment in prison and on parole.<sup>7</sup> That same year, the program hired a researcher to collect and analyze data that could help program supervisors continue to improve the program. The following year, after being presented with research findings regarding the impact of the use of the polygraph in the program, the General Assembly allocated additional funding to pay for polygraph examinations for inmates participating in sex offender treatment in prison and on parole.

From the onset, those who developed the SOTMP intended to design and implement the residential program as a *modified* TC. That is, some of the traditional principles of TC intervention--originally designed as a treatment modality for adults addicted to alcohol and/or drugs--were adapted to accommodate psychological issues related to sexual offending behavior. For example, traditional drug and alcohol TCs usually hire recovering addicts to work in the program. As participants progress in the program, they take on leadership roles whereby they may exert power over others with lower program status. However, because sex offenders abuse power in the commission of their crimes, SOTMP administrators consider these traditional components of TC intervention to be non-therapeutic and potentially dangerous for use with this population.<sup>8</sup>

Between April 1993 and March 2003, 723 inmates were admitted to the TC. Of these, 641 were discharged and 82 remained active.<sup>9</sup>

---

<sup>6</sup> Information obtained from a document entitled "SOTMP Funding History," obtained from administrators of the CDOC sex offender treatment program.

<sup>7</sup>The grant was obtained from the Division of Criminal Justice's Drug Control and System Improvement Program's (DCSIP) Byrne Formula funds from the Bureau of Justice Assistance in the U.S. Department of Justice.

<sup>8</sup>This focus on egalitarian relationships is a key difference between this program for sex offenders compared to traditional TCs for substance abusers.

<sup>9</sup> Information provided by the Program Director.

## C. The SOTMP Today

According to TC administrators, the program has changed to reflect research-based advances in clinical approaches to treat sex offenders. Also, based on resource allocations, it has expanded the number of offenders who receive treatment. Further, over the years, the treatment staff has accumulated considerable experience with what approaches tend to work and not work well in the prison environment. (See Figure 1 on the next page for a description on how offenders are integrated into the TC community).

**Mental Health Fundamentals.** Today, offenders are still expected to volunteer for participation in a pre-SOTMP treatment module that provides fundamental mental health concepts. These groups meet for a minimum of 18 session-hours (the actual number of session-hours may vary depending on the progress of the group). Depending on where offenders are housed during participation in this pre-SOTMP module, treatment may be provided by staff from general mental health, education, or the SOTMP.<sup>10</sup> When inmates complete this module, they may proceed to Phase I of the SOTMP.

**Phase I.** To be accepted into Phase I, inmates must admit to a sex offense, see sex offending as a current problem, and must be willing to discuss it in the context of treatment. Phase I programming is available at several DOC facilities including Fremont, Centennial, and Sterling. Phase I is also offered for special populations including developmentally disabled (at Territorial), chronically mentally ill (at San Carlos), Spanish speaking inmates (at Fremont), and female offenders (at Colorado Women's Correctional Facility). Phase I participants are tested on content of the curriculum delivered. Inmates must successfully complete Phase I before they can participate in Phase II, the therapeutic community.

*Phase I programming is available at several DOC facilities including Fremont, Centennial, and Sterling. Phase I is also offered for special populations including developmentally disabled (at Territorial), chronically mentally ill (at San Carlos), Spanish speaking inmates (at Fremont), and female offenders (at Colorado Women's Correctional Facility). Phase I participants are tested on content of the curriculum delivered. Inmates must successfully complete Phase I before they can participate in Phase II, the therapeutic community.*

**Phase II.** The modified TC, currently a 96-bed program located at Arrowhead Correctional Center, is the final component (Phase II) of the SOTMP offered inside the walls of the Colorado Department of Corrections (CDOC).<sup>11</sup> The modified TC shares space with the drug and alcohol therapeutic community, which also operates 96 beds. Inmates must agree to be accountable for their own behaviors as well as the behaviors of their "brothers" as a condition of entering treatment at the therapeutic community.

*Inmates must agree to be accountable for their own behaviors as well as the behaviors of their "brothers" as a condition of entering treatment at the therapeutic community.*

<sup>10</sup> Inmates participating in this module are not necessarily identified as sex offenders. However, according to interview data, if they are so identified and have been recommended for treatment, and if there are enough to form a group, efforts are made to use SOTMP therapists.

<sup>11</sup> See Appendix A for a flowchart of the SOTMP.

**Figure 1: How Offenders are Integrated into the Community**

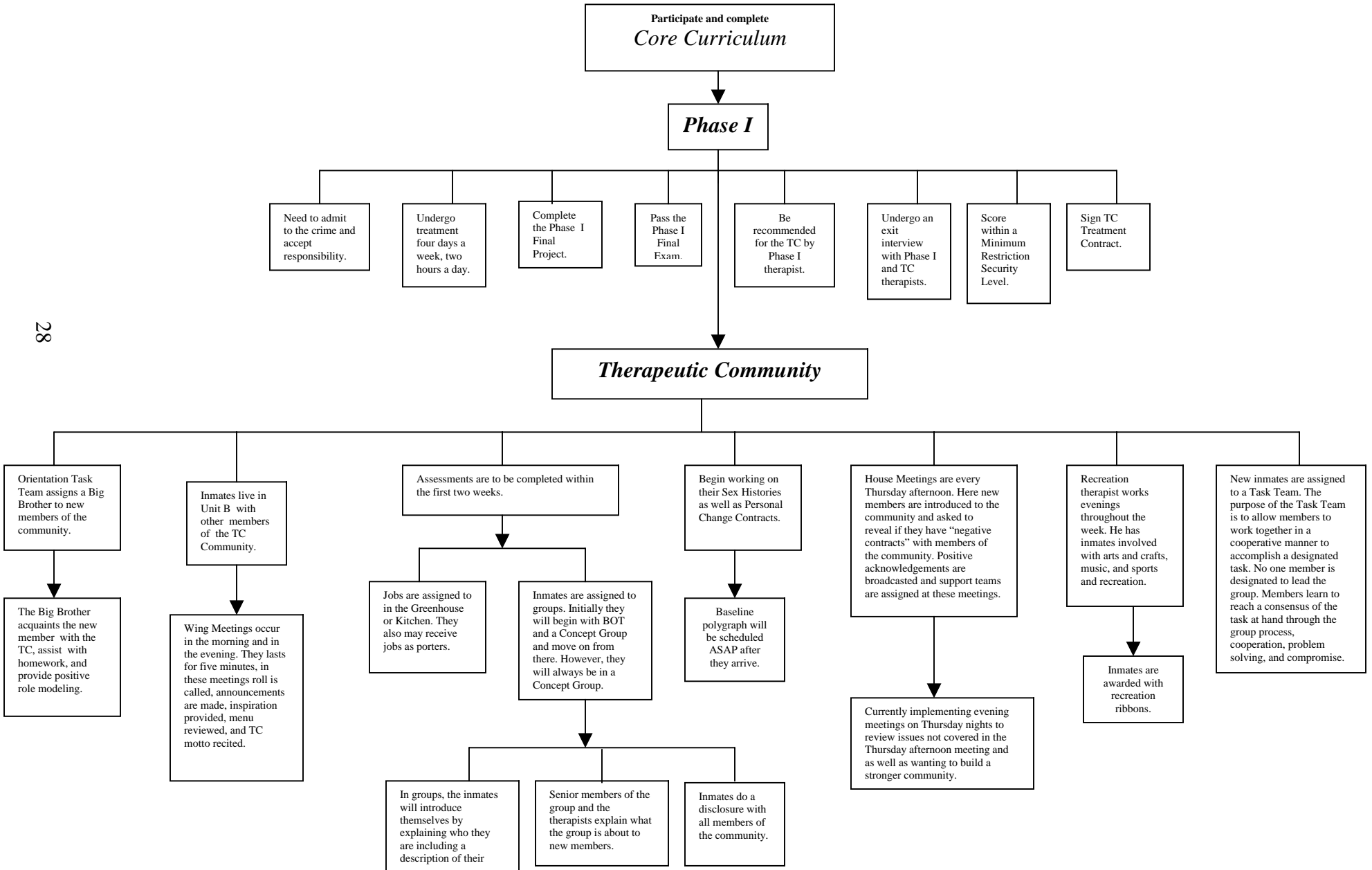

## **A Few Words About Therapeutic Communities**

Therapeutic communities (TCs) have been a method of treatment for drug abuse and addiction for nearly 40 years. *Many studies have found this approach to be an effective means of treatment for substance abuse, reducing relapse to drug use and criminal recidivism (for example, Field, 1989; Inciardi et al., 1997; Prendergast, Farabee, and Cartier, 2001; Shapiro, 2001; Wexler, Falkin and Lipton, 1990; 1998). Specifically, research has found that clients who have successfully completed drug treatment in a TC are significantly less likely to use cocaine, heroin, and alcohol; to engage in criminal behavior; to be unemployed; and to display indicators of depression*<sup>12</sup> (Hubbard, 1997). The most comprehensive study of the effects of TCs on rearrest for adult offenders concluded that these programs “do significantly reduce recidivism” (Lipton, Pearson, Cleland and Yee, 2003:66). Further, the latter study found that those who received more treatment were more likely to avoid recidivism (Lipton, et al., 2003).

*Progress in treatment requires motivation to change. DeLeon (1995:1610), as cited by Lipton et al., 2003)) discusses the need for the individual to fully engage in the treatment regime by noting that treatment “is not provided but made available” to individuals who then must commit to the process of change in themselves and in others. Lipton, et al. (2003:66) notes that recovery depends on positive and negative pressures to change, and remaining in treatment requires continued motivation to change.... Changes in lifestyle and identity are gradually learned through participating in various roles in the community.... It is clear from the research that the process only begins in the prison and, to be genuinely and lastingly effective, it must continue in the community.”*

*The National Institute on Drug Addiction in the U.S. Department of Health and Human Services funded much of the research on substance abuse and TCs. The multitudes of studies on substance abuse have resulted in a significant understanding of the problem. Sex offender treatment--the beneficiary of a very small fraction of federal research dollars by comparison (the current study being an exception)--has tended to follow approaches to drug treatment in theory and practice.*<sup>13</sup>

*Federal policy makers viewed the strength of the TC research findings, along with the expanding number of substance addicted prisoners, as reasons to authorize spending the largest sum ever for correctional treatment. Beginning in 1996, Congress created a formula grant program in the U.S. Department of Justice’s Corrections Program Office. The new program, called the Residential Substance Abuse Treatment (RSAT), dedicated \$270 million over five years for the development of drug and alcohol TCs in state and local correctional facilities (Lipton, 1998). The availability of funding led to a significant expansion of in-prison TCs for substance abuse. A survey of North American prisons conducted by the Association of State Correctional Administrators (ASCA) in July 2000 found 252 active TCs in 40 states, the U.S. Bureau of Prisons, and the federal prison system in Canada. Based on survey findings of implementation plans, this number was expected to rise to 289 by the end of 2002 (Rockholtz, 2002). A consequence of this level of financial support and program expansion is that the TC, as a method of intervention, has moved into the mainstream in terms of treatment modalities, challenging traditional counseling-based approaches.*

<sup>12</sup> The follow-up period was 12 months in this study (Hubbard et al, 1997).

<sup>13</sup> Drug studies have demonstrated that the “neurobiological basis of drug abuse and addiction is essentially the same, regardless of the drug taken or the person taking it” (Hanson, 2002). This level of confidence in our understanding of sexual offending behavior remains less certain.

**Phases III and IV.** The SOTMP is a component of the DOC's Risk Assessment Management (RAM) Program. The RAM Program provides specialized treatment and supervision for sex offenders in the form of a service continuum throughout incarceration and parole. Phases III and IV are both provided in the community through the RAM Program, collaborating with treatment staff inside the prison. Phase III provides specialized community corrections placements for sex offenders, and Phase IV involves sex offenders on parole. According to the SOTMP Resource Guide (2001), these offenders are to receive intensive treatment, specialized supervision, and polygraph monitoring while they are on parole or assigned to community corrections. This supervision is intended to ensure that the offender begins or continues treatment in the community, develops and implements a relapse prevention plan, and is monitored and polygraph tested on topics related to his or her high-risk areas. The supervision is coordinated through specially trained RAM officers, SOMB-approved community treatment providers, and SOMB-approved polygraph examiners, as specified in statute (C.R.S. 16-11.7-101 to 107).

## **D. The Purpose of the Sex Offender Therapeutic Community in Colorado**

*The modified sex offender TC houses inmates together in a therapeutic milieu where individuals work and live with others who are working on similar treatment issues.*

**The Modified Sex Offender TC.** The modified sex offender TC houses inmates together in a therapeutic milieu where individuals work and live with others who are working on similar treatment issues. The SOTMP is modified from traditional drug and alcohol TCs to accommodate sex offender-specific issues. These differences were explained in material provided to DCJ researchers by SOTMP administrators, are described here:

*Sex offenders are much more comfortable operating from a power position. They evaluate relationships in terms of who has more power and "how can I increase my power in this relationship?" They tend to have deficits in establishing mutually caring relationships on the basis of equality. We designed this TC to minimize opportunities for power or control over others and to maximize opportunities for equal peer relationships and responsibility for others. We also wanted to teach offenders to respond appropriately to confrontation and conflict. Therefore, we require offenders to use non-offensive language, a behavior that is usually allowed in drug and alcohol TCs. All of this is very different from the "game" that is used in many drug and alcohol TCs. Further, we wanted to maximize peer monitoring instead of using hierarchical monitoring, and we wanted inmates to progress to higher treatment levels by assuming greater responsibility instead of greater power over other participants.*

The intent of the SOTMP, according to the SOTMP Resource Guide (SOTMP, 2001) is (1) to provide treatment to sex offenders who are motivated to change to a more appropriate lifestyle and eliminate sexual assault behavior, (2) to collect information on the offenders and the program components to further the study of sex offenders, and (3) to increase public safety. Table 1 on page 32 was obtained from training materials used by the SOTMP, describes how the TC is designed to address specific problems that sex offenders must learn to manage.

The TC targets sex offenders who have successfully completed Phase I<sup>14</sup> and are within eight years of parole eligibility, have a sentence of lifetime parole, or are 18 months away from prison discharge without parole. To participate in the TC, inmates must be motivated to work toward eliminating sexual assault behavior and they must accept responsibility for changing their destructive actions. The TC program addresses offenders' life skills and their understanding of the world, others, and themselves. It also seeks to teach offenders to develop socially appropriate and non-sexually aggressive responses to their problems. Treatment topics include relapse cycle and prevention, cognitive restructuring, sexuality, social skills, and levels of denial. According to the SOTMP Resource Guide (SOTMP, 2001: Part 2, Section E), the treatment goals for offenders participating in the TC include:

*To participate in the TC, inmates must be motivated to work toward eliminating sexual assault behavior and they must accept responsibility for changing their destructive actions.*

1. Applying and incorporating the material learned in Phase I into his lifestyle.
2. Identifying and changing distorted thinking.
3. Preparing for living a responsible lifestyle in the community.
4. Realizing the importance of developing a balanced lifestyle and monitoring his thoughts and behaviors for the rest of his life.
5. Identifying his relapse cycle and methods for intervention in the cycle.
6. Realizing the importance of sharing his relapse cycle and methods for intervention with significant others in his life.
7. Practicing and incorporating a model for solving problems.
8. Further evaluation of the inmate and his problem areas.<sup>15</sup>

The therapeutic community employs treatment stages that reflect increased levels of personal and group responsibility. In a traditional TC, the key agent of change is the community itself, so TC members are expected to act in ways that influence attitudes, perceptions and behaviors of fellow participants, creating a psychologically healthy environment. A fundamental principle is the "self-help" aspect of TCs, meaning that the main contributors to the change process are the clients themselves. TC members are expected to become role models who actively reflect the values of the community (National Institute on Drug Abuse, 2002).

---

<sup>14</sup> Phase I participants meet for psycho-educational therapy four days a week for approximately six months.

<sup>15</sup> From *Sex Offenders: Myths, Facts and Treatment: A Community Outreach Project and Resource Guide*. Sex Offender Treatment and Monitoring Program, Colorado Department of Corrections, Revised January 2001, cited in this report as (SOTMP, 2001).

**Table 1: Utilizing Therapeutic Communities in Advanced Sex Offender Treatment<sup>16</sup>**

| Problem Area                     | TC Method   |
|----------------------------------|---|
| Secrecy                          | <ul style="list-style-type: none"> <li>• Public living</li> <li>• Ask for help and support</li> <li>• Disclose cycle of abuse</li> <li>• 24-hour accountability</li> </ul>  |
| Self-Centered                    | <ul style="list-style-type: none"> <li>• Community responsibility</li> <li>• Task teams</li> <li>• Requests for group (RFGs)<sup>17</sup></li> <li>• Pull-ups<sup>18</sup></li> <li>• Community service projects</li> </ul> |
| Power and Control                | <ul style="list-style-type: none"> <li>• Earn progression which brings additional responsibility without power</li> <li>• No hierarchy</li> <li>• Peer monitoring</li> <li>• Concept Group</li> </ul>                       |
| Cognitive Distortions            | <ul style="list-style-type: none"> <li>• Scrutiny of all areas of life: work, leisure, treatment</li> </ul>   |
| Poor Interpersonal Relationships | <ul style="list-style-type: none"> <li>• Relate to peers with feedback and scrutiny on developing healthy relationships</li> </ul>  |
| Lack of Empathy                  | <ul style="list-style-type: none"> <li>• Value: you are your brother's keeper</li> <li>• Immediate feedback</li> </ul>  |
| Impulsivity                      | <ul style="list-style-type: none"> <li>• Immediate consequences for acting-out behavior</li> </ul>  |
| Dishonesty                       | <ul style="list-style-type: none"> <li>• Culture supports honesty and self-disclosure</li> </ul>  |
| Deviant Sexual Interest          | <ul style="list-style-type: none"> <li>• Support to help control urges and 24-hour monitoring</li> </ul>  |
| Criminal Thinking                | <ul style="list-style-type: none"> <li>• Culture does not support convict code</li> </ul>   |
| Fear of Genuine Relationships    | <ul style="list-style-type: none"> <li>• Ability to practice genuine relationships and support systems</li> </ul>   |
| Feelings of Hopelessness         | <ul style="list-style-type: none"> <li>• Expectation that change is possible</li> <li>• Support for change</li> </ul>   |

<sup>16</sup> Information obtained from Risk Assessment Management Program Staff Training materials.

<sup>17</sup> Inmates may fill out a slip requesting group time for themselves or one of their peers. This slip is used to inform the community that they have a concern about their own behavior/thinking or their peer's behavior/thinking. This is a tool used to ask for feedback or help from the community.

<sup>18</sup> Pull-ups allow inmates to confront each other in an appropriate way by telling him that he is doing something that is against the rules of the program or personally harmful as a way to bring another person's behavior up to a responsible level. A pull-up of awareness is a sign of "responsible behavior" and "being your brother's keeper."



**The Personal Change Contract and Family Support.** According to the treatment manual, a core program component is helping the inmate develop a personal change contract (PCC) that will assist him in modifying and maintaining a safe and healthy lifestyle. The personal change contract is a working document that changes as inmates learn more about themselves through the treatment process. This contract is to be shared with the inmates' family and support system. Inmates are encouraged from the beginning of treatment to involve family members or other support people in their efforts to change. They are asked to send letters to their family members or support persons inviting them to attend a support meeting. These meetings occur every quarter and are offered as a way to educate family members/support persons on the dynamics involved in the offending cycle. The SOTMP offers these programs around the state in order to accommodate family/support members who may live too far from the facility in Canon City, Colorado to attend. Therapists from both Phase I and Phase II attend the family/support meetings and are available to meet and answer questions for family/support members after the meetings. The therapists will also set a time to meet with the family/support group in order to review the inmates personal change contract prior to release. The purpose of the meeting is to assist the family in becoming a support system for the offender in monitoring high-risk thoughts, feelings, and behaviors.

*A core program component is helping the inmate develop a personal change contract (PCC) that will assist him in modifying and maintaining a safe and healthy lifestyle. The personal change contract is a working document that changes as inmates learn more about themselves through the treatment process.*

*Inmates are encouraged from the beginning of treatment to involve family members or other support people in their efforts to change.*

**Circles of Support and Accountability.** The concept of circles of support came from the Community Reintegration Project for the Mennonite Central Committee in Ontario, Canada. The Mennonite Central Committee developed this program in order to reduce the risk of sex offenders in the community by easing their transition into the community, and hopefully, the stress associated with that transition. The program was developed to offer support to those offenders without family or other forms of support. Volunteers from the faith community form a "circle of support and accountability" for offenders. The offender must accept the circle volunteers' help and advice and pursue a predetermined course of treatment. According to the Canadian model, 6-8 volunteers per offender are desirable so that someone is available to have contact with the individual everyday.

In Colorado, the Restorative Justice Department in the city of Denver has investigated developing a similar program to assist with the safer community reintegration of sex offenders. Currently the Circles of Support and Accountability program in Colorado is a pilot project, seeking additional funding. The goal of the program is to provide an opportunity for released sex offenders who ask for support to re-enter the community in a manner that facilitates the greatest public safety. The program specifies that groups of 7-8 volunteers from the faith community become the discharged offender's support team. The program model and core principles have been established. Since many of the offenders from the SOTMP program will be referred to Circles of Support and Accountability, protocols to work with DOC are being developed. Five volunteers have completed training on working with sex offenders. Unlike the Canadian model that works

with offenders directly discharged from prison, the Colorado program will provide support for individuals accepted into community corrections or parole.<sup>19</sup>

## **E. Brief National Overview of Sex Offender Treatment in Prison<sup>20</sup>**

In August 2000, the CDOC conducted a survey of corrections departments in the 50 states and the District of Columbia to obtain more information about sex offender treatment and monitoring programs nationwide, legislative influences on state programs, and program structure within the state prison systems. The survey found that sex offender treatment programs were available in 39 state prison systems. Twenty of these states offered intensive forms of treatment through “therapeutic communities” or residential programs although the term “therapeutic community” seemed to describe a wide range of residential programming.

According to the survey, the 20 programs modeled on traditional drug and alcohol therapeutic communities were highly structured residential programs with rules and regulations, a formalized community life, and an entire correctional staff trained to reinforce the behavioral change expected through group therapy. In these communities, survey respondents reported that participants worked and lived together in a therapeutic milieu that involved all aspects of an offender’s life. Community life focused on clearly defined methods for holding each other accountable for specific behaviors. Some of these states used a modified therapeutic community or a residential program with certain features of a therapeutic community such as a segregated unit for participants, specially trained staff, intensive group therapy, and a reinforced atmosphere of mutual support.

Survey respondents in states offering specialized treatment indicated agreement on a “no cure” philosophy regarding sexual offending behavior, but this perspective was combined with the belief that sex offenders can learn interventions to control their behavior.<sup>21</sup> A number of the programs, according to the survey, were designed to provide external support and controls, primarily in the form of transition planning and specialized supervision in the community. Family education surfaced as an emerging critical element in the transitional and post-release support, a finding consistent with the current literature on sex offender treatment (Thomas and Viar, 2001; Mussack and Carich, 2001).

---

<sup>19</sup> Liability issues are of concern for volunteers who work with inmates directly discharged. Volunteers are protected from liability concerns when working with inmates on parole and community corrections as those agencies bear the liability burden.

<sup>20</sup> Information presented in this section was obtained from <http://www.doc.state.co.us/programs.htm>

<sup>21</sup> The no cure idea is a basic assumption in sex offender therapy according to Mussack and Carich (2001) and is a main impetus behind the propagation of civil commitment laws in the 1990s. The extent to which this population can be “cured” remains an empirical question; however, results of recent meta-analytical studies of sex offender treatment reveal that, overall, treated offenders fare better than untreated offenders (Hall, 1995; MacKenzie and Hickman, 1998; Polizzi et al., 1999). Relapse is “...a choice on the part of the offender and not necessarily an indication of a treatment program’s effectiveness” (Freeman-Longo and Knopp, 1992).

Treatment programs across the nation have identified a unanimous goal of public safety. Cognitive-behavioral group therapy, with relapse prevention as the focus of treatment, is the most common practice for working with sex offenders, according to data obtained from the survey.<sup>22</sup> Survey responses indicated that many state sex offender programs were developed based on recent research regarding what works with treating sex offenders.

*Treatment programs across the nation have identified a unanimous goal of public safety. Cognitive-behavioral group therapy, with relapse prevention as the focus of treatment, is the most common practice for working with sex offenders.*

## **SUMMARY**

The Department of Corrections' sex offender treatment program began in 1985 when two therapists began facilitating groups at three prisons. In the early 1990s, those therapists visited prisons in four states to investigate the development of intense sex offender programs fashioned after drug and alcohol therapeutic communities. In 1993, the CDOC opened a 48-bed TC for sex offenders at Arrowhead Correctional Center. The size of the sex offender TC doubled in 1996 with additional funding from the General Assembly. To enter the TC, inmates have to successfully complete Phase I, a 6-month psycho-educational group therapy program. Between 1990 and July 2002, 6,835 sex offenders were released from the CDOC.<sup>23</sup> Of this number, 1,313 were released having received specialized treatment while in prison: 907 participated in Phase I, and 406 participated in Phase II, the therapeutic community. One hundred and forty three (143) were women.

---

<sup>22</sup> The cognitive behavioral approach, with the focus on relapse prevention, has been supported by research (Marshall and Williams, 1998; Mussack & Carrich, 2001; Loss, 2001).

<sup>23</sup> This number includes offenders with a current or past conviction for a sex crime, and offenders who committed sexual assaults while serving time on other conviction crimes.

## SECTION THREE: RESEARCH QUESTIONS, DATA COLLECTION AND METHODS

### A. The Research Questions

This research serves to answer two primary questions:

- (1) *Are the components of CDOC's sex offender therapeutic community grounded in theory and best practice?*
- (2) *Are outcomes for sex offenders who receive SOTMP services better than the outcomes of sex offenders who do not receive these services?*

### B. Data Collection and Methods: Question 1

***Are the components of CDOC's sex offender therapeutic community grounded in theory and best practice?***

We collected data from multiple sources over several months. First we reviewed the sex offender clinical and research literature and used the in-prison standards developed by Therapeutic Communities of America (TCA) to identify relevant theory and best practices. Because CDOC's TC emphasizes the role of the group process in the delivery of services, selected observations of all groups comprising the core curriculum of the therapeutic community were conducted over a three-month period. We attended staff, team and job impact meetings and observed family support education activities. We conducted personal interviews with therapists and corrections administrators. We held focus groups with offenders and parole officers responsible for supervising offenders after release. We reviewed documents related to the program including the program manual. Since trained service providers are key to any successful program, we were particularly interested in how training was provided to therapists in the TC. We developed a questionnaire to probe this issue; ten out of eleven therapists completed and returned the instrument. Although data collection from files was not the primary focus of the research activities in this study, the files of 578 offenders who moved through the therapeutic community since its inception were examined to locate individual treatment plans, and when appropriate, personal change contracts. Treatment plans and personal change contracts were selected for review because of the importance of treatment goals and offender intentions to stay safe when eventually released into the community. Summaries of data collection activities are contained in Tables 2 and 3 on pages 38 to 40, respectively.

#### *Environmental Scan*

Before beginning the data collection, an ORS researcher spent six days at the therapeutic community to observe program elements, talk to staff, attend meetings and examine files. The purpose of this *environmental scan* was to acquire basic knowledge about the program, its history and how it functions. This information was fed into the research design to ensure that data collection was focused and meaningful. We also developed appropriate confidentiality agreements with the Colorado Department of Corrections to permit us to collect various data on offenders.

## Group Observations

The treatment groups are the “heart and soul” of service delivery for this program. Groups are organized in a “block schedule” covering a one-week period.<sup>24</sup> For the purpose of organizing the observations, we referred to two consecutive blocks as *Week A* and *Week B*. Block schedules were maintained for four-month periods. A total of 67 group observations were conducted over a three-month period (from March 2002 to June 2002) that spanned two block schedules. To reduce the bias associated with this type of qualitative research, two researchers simultaneously observed 90% of the groups (scheduling necessitated one observer in 10% of the groups). Groups and therapists were observed multiple times to reduce the likelihood of bias attributed to a single observation. So the team could observe all groups offered by the TC, four researchers conducted observations during Week A, and two researchers covered groups in Week B.

*The treatment groups are the “heart and soul” of service delivery for this program.*

To assist us in observing groups, we used a Group Process Measure form, currently being developed by the Colorado Department of Corrections.<sup>25</sup> This form attempts to measure group process in several domains including the administrative, instructional and therapeutic skills of the facilitator.<sup>26</sup> However, the instrument targets the characteristics of the therapist conducting the group rather than the group as a whole, so we modified the instrument to describe the actions of the group rather than the facilitators. This was an important change since the TC prioritizes inmates challenging and providing appropriate feedback to group members. The primary purpose of the instrument was to assist us with standardizing our observations.

## Meetings

It was important to review every aspect of the TC program, so we attended as many TC activities as possible. These included staff, house and job impact meetings and SOTMP team and family support education meetings. We observed re-entry interviews<sup>27</sup> as well as 64/70 staffings.<sup>28</sup> Table 2 on the following page describes the types and number of meetings we attended.

---

<sup>24</sup> The transition to a block schedule happened two years ago to help offenders progress through groups faster. A copy of the Block Schedule can be found in Appendix B.

<sup>25</sup> O’Keefe, M.L., Klebe, K.J. & Timken, D. (2001). Group Process Measure, Unpublished test.

<sup>26</sup> Examples of individual measurements under these domains include adequate and comfortable physical setting; organization of the facilitator: defining terms, concepts and principles; maintaining client interest; clarification; question style; and consistent modeling of appropriate behavior. A copy of the instrument is contained in Appendix C.

<sup>27</sup> Re-entry interviews are conducted with inmates who left the TC but have applied to return.

<sup>28</sup> A 64/70 is a monthly meeting that is held to score inmates on their participation in daily processes as well as their overall monthly progression.

**Table 2: Summary of Meetings Attended by Research Staff**

| <b>Meetings</b>            | <b>Frequency of meeting</b> | <b>Purpose of the meeting</b>   | <b>Number of research observations</b> |
|----------------------------|-----------------------------|---|--|
| Staff Meetings             | Daily                       | Announcements made, updates on groups, inmates, polygraph results.  | 13                                     |
| House Meetings             | Weekly                      | TC community updates, announcements and speeches made, support teams selected, other activities.  | 4                                      |
| Re-entry interview         | As needed                   | Two therapists interview offenders who left or previously terminated from the TC and assess the offender's readiness for re-entry.  | 1                                      |
| 64/70 Meetings             | Monthly                     | TC staff rate inmates' participation and progress.  | 2                                      |
| SOTMP Staff Meetings       | Monthly                     | SOTMP therapists receive training and updates. Staffings occur and the appropriateness of offender "S" codes are reviewed.  | 2                                      |
| Job Impact Meetings        | Monthly                     | TC staff discuss therapist issues.  | 2                                      |
| Support Education Meetings | Quarterly                   | Family or community members interested in supporting offenders when they return to the community discuss the concept of support and provide/obtain information about sex offending behaviors. | 1                                      |

### Interviews

Individual interviews with three categories of staff were conducted over a three-month period between April 2002 and June 2002. Eleven staff that has been with the TC since its inception or for several years was interviewed to gather opinions about changes in the TC that have occurred over time. Other interview topics included the types of assessments conducted, training received, hiring, and quality control issues.<sup>29</sup>

Seven wardens, associate wardens from other facilities that house sex offenders, and directors from several divisions within the DOC were interviewed to assess perceptions regarding how the TC fits into the goals and values of the Department of Corrections.<sup>30</sup> Topics such as positive and negative aspects of the TC were included in the interview.

Four directors, therapists, and case managers from Community Corrections programs that accept sex offenders from the TC were interviewed to gather information regarding the types of transitional services offenders receive.<sup>31</sup>

<sup>29</sup> A copy of the interview instrument is included in Appendix D.

<sup>30</sup> A copy of the interview instrument is included in Appendix E.

<sup>31</sup> A copy of the interview instrument is included in Appendix F.

## Staff Questionnaires

Ten out of the 11 current TC therapists responded to our questionnaire that addressed training and support issues and other topics.<sup>32</sup>

## File Collection

We reviewed the files of 578 offenders<sup>33</sup> who participated in the Therapeutic Community since its inception in 1993. We were unable to review 36 (6 percent) of the files because the files could not be located. Missing files included some members with short TC stays. The focus of the file review was to determine whether the file contained individual treatment plans and, if appropriate, personal change contracts,<sup>34</sup> since these documents are key to service delivery and public safety.

## Focus Groups

Four focus groups with offenders were conducted:

- Those currently in the TC who had been in the TC for a year or more,
- Those currently in the TC who had been at the TC a year or less,
- Those who have been terminated or quit and have not returned to the TC, and
- Those who have been terminated or quit and came back to the TC.

Participants in the first three groups were randomly selected and consisted of nine to ten participants each. The fourth focus group included all five inmates who had terminated or quit the TC, and returned and were currently participating in the program. Inmates were asked to explain why they participated in the TC, as well as their perceptions about helpful and unhelpful program elements and suggestions for change. Inmates who left the TC were also questioned about why they left and, as appropriate, why they returned or have not returned.

To understand more about how inmates on parole transition into the community, we conducted a focus group with 12 Parole and Risk Assessment Management (RAM)<sup>35</sup> officers from the Denver metro area and El Paso County. Questions posed during this session addressed the supervision of sex offenders, polygraphs, training, support, communication with treatment providers and polygraph examiners, and the Sex Offender Management Board's *Standard 5.7* regarding the prohibition of contact with children and the victim of the crime.

*To understand more about how inmates on parole transition into the community, we conducted a focus group with 12 Parole and Risk Assessment Management (RAM) officers from the Denver metro area and El Paso County.*

---

<sup>32</sup> A copy of the questionnaire is included in Appendix G.

<sup>33</sup> A copy of the data collection instrument is included in Appendix H.

<sup>34</sup> Inmates do not immediately develop a Personal Change Contract when they enter the TC. This occurs later in the program, so not all program participants would be expected to have a PCC. However, this has recently changed and PCC's are being done within the first two weeks of assessments and it will continuously be revised as they complete different groups.

<sup>35</sup> A RAM officer is trained to arrange specialized treatment and supervision for sex offenders in the form of a service continuum throughout incarceration and parole.

A focus group was also conducted with three offenders who had been released from the TC into the same community corrections program to learn more about the experience of offenders who transition into the community through community corrections. After sharing information about the results of the study with staff, we conducted another focus group with some of the TC offenders who participated in the previous focus groups to obtain more information about the progression of inmates through the TC program.

All focus groups were audio-recorded and transcribed. A content analysis was performed to extract and compile underlying themes.

### Document Review

We reviewed the literature on therapeutic communities and effective interventions for sex offenders. We used the Therapeutic Communities of America (TCA) standards developed by its criminal justice committee and the White House Office of National Drug Control Policy, published as the *Revised TCA Standards for TCs in Correctional Settings (1999)*. We also reviewed material from treatment programs developed in other states, the lengthy SOTMP treatment manual, and the material used in family support education meetings and the 40-hour training curriculum offered by the TC.

In addition to the 25 meetings observed (see previous table), the table below provides a summary of the other data collection activities conducted for this evaluation.

**Table 3: Summary of Other Data Collection Activities**

| <b>Other Data Collection Activities</b>                                |               |
|--|---------------|
| Group Observations   | 67 observed   |
| Staff Interviews   | 11 conducted  |
| Administrative Interviews  | 7 conducted   |
| Offender Focus Groups  | 6 conducted   |
| Parole Focus Group   | 1 conducted   |
| File Review for Individual Treatment Plan and Personal Change Contract | 578 collected |
| Treatment Staff Questionnaires   | 10 collected  |

## **C. Data and Methods: Question 2**

### ***Are outcomes for sex offenders who receive SOTMP services better than the outcomes of sex offenders who do not receive these services?***

The purpose of this analysis was to compare offenders who received sex offender treatment to those who did not on several outcome measures: parole revocation, arrest, new court filing, and return to prison. Cases discharged to supervision were examined separately from those discharged without a parole period since supervision by a parole officer considerably alters the release situation for the inmate.

### Data

Data extracts were obtained from the Department of Corrections Information System (DCIS). Data on treatment received, conviction crimes as stated in the court mittimus, parole versus inmate status changes, and offender demographics were provided by the DOC. Polygraph exam results, LSI, MCMI, and other assessment data were also



gathered from a variety of sources and linked to the DCIS extract; however, these data elements were missing on many cases and so were not analyzed for this report.

The following data sources were used:

- **Parole outcomes** were compared using the revocation data available in the same Department of Corrections DCIS extract used to identify the sample;
- **Arrests** were obtained from the Colorado Crime Information Center (CCIC), managed by the Colorado Bureau of Investigation.<sup>36</sup>
- Judicial **filing** data, maintained by the Colorado Judicial Department, were extracted from the Integrated Colorado Online Network (ICON).<sup>37</sup>
- **New incarcerations** were identified from the original DCIS extract supplied by the Department of Corrections.

Records were identified for electronic extraction from CCIC and ICON by using searching on state ID number (SID), social security number, FBI number, name, and date of birth.

### The Sample

The sample consists of more than 3,000 male sex offenders who discharged their sentences between April 1, 1993 and July 30, 2002. The 1993 date marks the introduction of the Sex Offender Therapeutic Community at the Colorado Department of Corrections. Inmates were considered a sex offender if they were assigned one of three codes on the Colorado Department of Corrections' Sexual Violence Scale (S-Code). Inmates selected for analysis were those assigned a status of S3, S4 or S5 during the target incarceration (see box below).

#### **The Use of the "S-Code" in Colorado**

*All inmates are programmed at the Denver Reception & Diagnostic Center (DRDC) upon entry into DOC. Each inmate receives a code based on his criminal history on the following Sexual Violence Scale.<sup>38</sup> The S-code indicates whether the inmate will be recommended for sex offense specific treatment. S-codes can be modified when new information is obtained on the case.*

- *S5 – Individuals with past or current felony sexual offense convictions.*
- *S4 – Individuals whose history indicates sexual assaults or deviance for which they may not have been convicted. These cases often involve plea bargains where the factual basis of the crime involved a sex offense.*
- *S3 – Incarcerated individuals who have committed sex offenses against staff or inmates, or who have displayed behaviors that indicate sexual abuse directed towards another.*
- *S2 – Individuals who were arrested/investigated for sexual offenses but have no documented conviction, or individuals who were initially coded S5, S4, or S3 but are not recommended for treatment after review by SOTMP staff.*
- *S1 – Individuals with no history or indication of sex offense behavior.*

<sup>36</sup> Arrest data (CCIC) and filing data (ICON) were obtained using the State of Colorado's Criminal Justice Decision Support System, a research-specific 'data mart' recently developed under SAC Grant # 2001-MU-CX-K006, OJJDP grant 2000-JB-VX-0008, and BJA NCHIP grants 20-RU-15b-16-1, 95-RU-15b-17-1, and 95-RU-15b-12-1.

<sup>37</sup> See footnote 36.

<sup>38</sup> Found in the SOTMP Resource Guide (Section E).

Many offenders in the sample had multiple incarcerations during the time period of interest. The target incarceration was identified by an offender's first discharge after April 1, 1993 and before July 30, 2002. For those who participated in sex offender treatment, the first discharge from an incarceration period involving some form of sex offender treatment was selected.

Juveniles and special populations, including Spanish speaking, chronically mentally ill and developmentally disabled inmates were excluded from the analysis because of potentially unique anomalies that might affect case outcome. The small number of these cases precluded separate analysis. In addition, cases discharged as executed or deceased, to interstate compact, detainer, additional charges, appeal bond, commutation and to probation were also excluded from analysis. Given the few females in the sample and that women are not treated in the TC at the Arrowhead facility, this group was also removed from the study.<sup>39</sup>

### Analysis Groups

#### *Treatment Groups*

Sex offenders were assigned to one of three treatment groups:

- **No treatment**, which included all of those who had less than 30 calendar days in Phase 1 treatment,
- **Phase 1** included those with more than 30 days in Phase 1 and no Phase 2 (or TC) treatment, and
- **Phase 2 (or TC)** treatment included those who participated in *both* Phase 1 and Phase 2 sex offender treatment.

Average follow-up time for each of these groups is presented in Table 4 on the next page.

It was not possible to identify cases that dropped out of treatment. Data were not available that specified the reason for non-completion of Phase I; for both Phase I and II, offenders could be terminated by staff or they could self-select to leave the program. Participation could also cease when an inmate was transferred to another facility. While between 60-75 percent of TC participants terminate the program, approximately 50% of these inmates reapply and return to the program (based, in large part, on proactive outreach by TC staff that follows each termination). While efforts have been made to record termination reasons, we found portions of these data to be unreliable.

---

<sup>39</sup> Approximately 500 cases were excluded because they had not been identified as a sex offender during the targeted incarceration. That is, this subgroup of offenders was identified as sex offenders during subsequent incarcerations rather than during the study period. Approximately 487 inmates who were considered to have anomalies in the assignment of S-codes were excluded as well.

**Table 4: Time at Risk from Discharge to Community**

|                     | <b>Days<br/>at Risk</b> | <b>Months<br/>at Risk</b> |
|---------------------|-------------------------|---------------------------|
| <b>No Treatment</b> |                         |                           |
| Mean                | 1707.15                 | 56.90                     |
| N                   | 2465                    | 2465                      |
| S.D.                | 977.99                  | 32.60                     |
| <b>Phase 1</b>      |                         |                           |
| Mean                | 1768.42                 | 58.95                     |
| N                   | 548                     | 548                       |
| S.D.                | 968.96                  | 32.30                     |
| <b>Phase 2</b>      |                         |                           |
| Mean                | 1358.48                 | 45.28                     |
| N                   | 325                     | 325                       |
| S.D.                | 894.48                  | 29.82                     |
| <b>TOTAL</b>        |                         |                           |
| Mean                | 1683.26                 | 56.11                     |
| N                   | 3338                    | 3338                      |
| S.D.                | 974.53                  | 32.48                     |

*Parole Supervision vs. Sentence Discharge*

Three offender release cohorts were analyzed. See Figure 2 on the next page for a visual description of the release cohorts. Analysis Group 1 consists of offenders released to their *first* parole supervision following their last treatment episode. For offenders in the non-treatment group, this was their first parole after April 1, 1993. For 89.0 percent of this sample, this was their only release to parole during the follow-up period. The outcome period for Analysis Group 1 commences when parole begins, and the measure of outcome is revocation. This is the group studied for the first analysis: Did treatment affect the revocation rate of parolees?

Analysis Group 2 consists of sex offenders whose final release from prison did *not* include parole. One-third of this group (33.4 percent) *previously* served parole terms and was revoked. For Analysis Group 2, the outcome period starts at the time of final discharge from prison.

Analysis Group 3 successfully completed their *final* parole period and were no longer under supervision. This group consists of those offenders who successfully completed their Analysis Group 1 status and a few offenders who failed a prior parole but successfully completed their last parole period. For 90.9 percent of Group 3, this was their only parole period. For Analysis Group 3, the outcome period for rearrest starts at prison release to parole. This group is analyzed both separately from and in combination with Group 2, depending on the specific analysis. Both Analysis Groups 2 and 3 are utilized for the second outcome analysis: Did treatment affect the rearrest rate of sex offenders released from the CDOC?

Figure 2: Outcome Study Groups

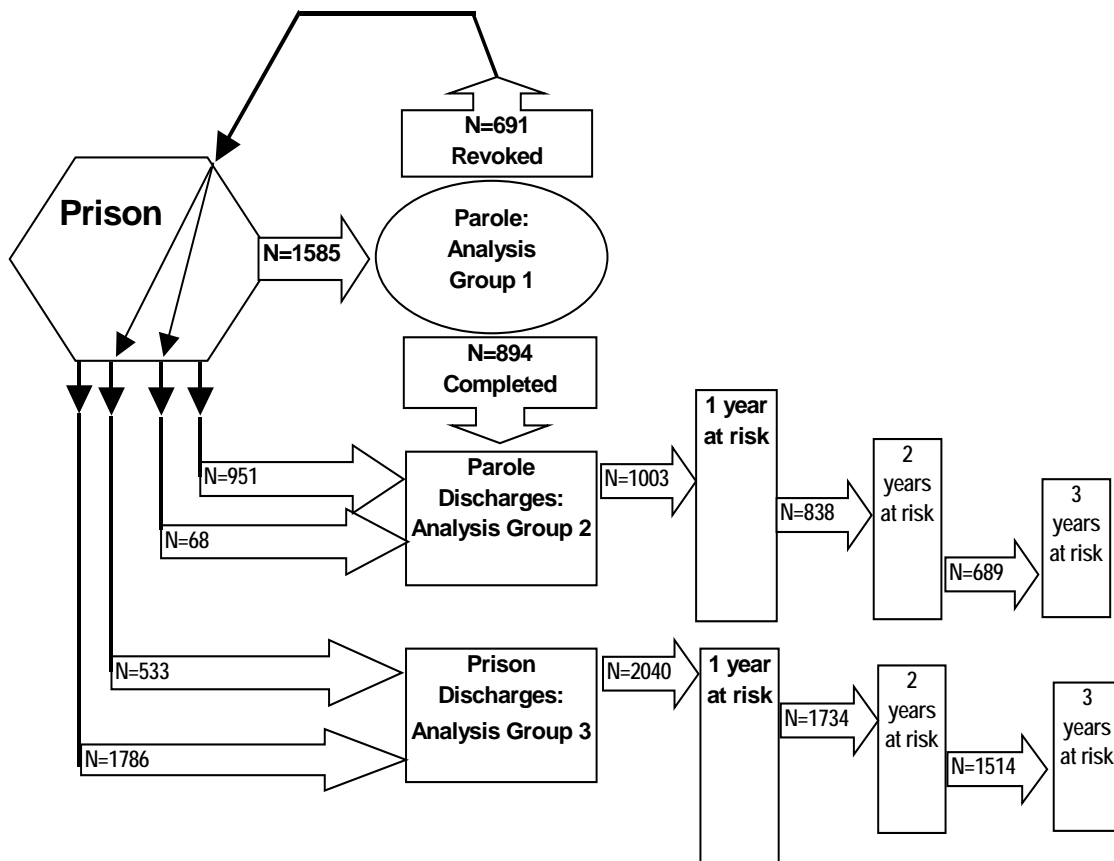

Outcome Measures

Cases released to supervision were examined separately from those discharged directly from prison without a parole period because supervision represents a considerable variation in the circumstances of release. The outcome measure for Group 1 is **revocation**; data from CDOC were not available to separate out technical violations from new crimes, and any return to prison is considered a revocation in the DOC data system.

As described above, official record sources were used to identify parole revocations and new arrests, new filings and new incarcerations. The arrest, filing and incarceration data

were categorized according to the index offense into sexual re-offending, violent re-offending, and all new offenses. These categories describe a range of criminal behavior resulting in arrest. Measures that reflect criminal behavior of any type are the most sensitive indicators of officially recorded failure since they indicate antisocial behavior and criminal thinking, assuming the arrest was legitimate. Re-arrest for a sex crime is the least sensitive measure since 80 to 90 percent of victims do not report

*Re-arrest for a sex crime is the least sensitive measure since 80 to 90 percent of victims do not report this crime, and not all sexual assaults reported result in an arrest.*

this crime, and not all sexual assaults reported result in an arrest.<sup>40</sup> Non-sexual offenses may be related to sexual offenses since for some offenders sexual offenses are at the end of a chain of deviant behaviors that can include non-sexual precursors.<sup>41</sup>

### Statistical Methods

Group outcomes were compared using the chi-square statistic. Length of time to failure was explored with a Kaplan-Meier survival analysis. A Cox proportional hazards regression model was used to examine group patterns of failure over time, and determine which, if any, of the available variables influenced recidivism. The use of this multivariate model renders a matched comparison group unnecessary since it controls for the variation across the three study groups.

For this analysis, due to the large sample size, alpha was set at .01. This means that one out of one hundred statistical analyses might find differences due to chance alone. We believe this will preclude spurious conclusions, but the reader must remember that analyses using large numbers of cases results in statistical power that can detect small and sometimes non-significant differences.

An analysis of time spent in treatment or “treatment dose” was conducted for the Phase 2 participants only (time in treatment data for the Phase 1 group was unavailable for analysis). To compare months spent in treatment, both Analysis of Variance and the non-parametric Mann-Whitney U tests were used with their application depending upon sample size. Since the number of cases involving only Phase 2 participants was relatively small, statistical power was reduced accordingly, so alpha was set at .05.

---

<sup>40</sup> Kilpatrick et al., 1992; Colorado Sexual Assault Prevention Program, 1998; Snyder, 2000.

<sup>41</sup> See *Sex Offender Treatment Program: Initial Recidivism Study*. Anchorage: Alaska Department of Corrections, Offender Programs, and Alaska Justice Statistical Analysis Center, Justice Center, University of Alaska Anchorage, August 1996. Executive Summary available at: <http://www.uaa.alaska.edu/just/publications/9602sotp.html>

## SECTION FOUR: TC STANDARDS AND THE ORGANIZATION OF THE FINDINGS

*The effectiveness of prison TCs for the treatment of substance abusing offenders (as measured by the significant reduction in criminal activity and substance abuse following treatment) led to the rapid expansion of these programs in prisons nationwide.*

As discussed previously, the effectiveness of prison TCs for the treatment of substance abusing offenders (as measured by the significant reduction in criminal activity and substance abuse following treatment) led to the rapid expansion of these programs in prisons nationwide. During deliberations of the 20<sup>th</sup> anniversary conference of the Therapeutic Communities of America (TCA), concerns surfaced about the proper implementation of these prison programs, especially regarding the aftercare component.

Knight et al. (1997) and Wexler (2000) found better outcomes for offenders who transitioned from prison substance abuse TCs through community-based programs.<sup>42</sup> The TCA's criminal justice committee obtained funding from the Ohio Department of Alcohol and Drug Addiction Services and the White House's Office of National Drug Control Policy (ONDCP) to develop and field test TC program standards and an assessment protocol that could be used by the American Correctional Association to accredit prison TC programs. Following field-testing in the Ohio Department of Corrections and elsewhere, the ONDCP published the *Revised TCA Standards for TCs in Correctional Settings* (1999). TCA joined the American Correctional Association (ACA) and drafted a further revised version of performance-based standards that will likely be published soon by ACA.<sup>43</sup>

*Because the TCA standards are based on clinical expertise and research, and because the standards grew out of an evaluation of TCs operated by the Ohio Department of Corrections, the findings presented in this report are organized according to the eleven components addressed by the TCA standards.*

Because the TCA standards are based on clinical expertise and research, and because the standards grew out of an evaluation of TCs operated by the Ohio Department of Corrections,<sup>44</sup> the findings presented in this report are organized according to the eleven components addressed by the TCA standards. Specifically, we use the TCA standards as a foundation for comparison to examine the relationship between TC activities, theory and what is considered "best practice" in the field. Organizing the study findings in this fashion

also provides a meaningful way to reflect the scope of this evaluation. The findings pertain to the following TCA components:

---

<sup>42</sup> In a recent study of Community Corrections in Colorado conducted by DCJ's Office of Research and Statistics, we found that offenders in both Diversion and Transition community corrections fared significantly better when they were released from the halfway house onto probation or parole supervision (English and Woodburn, 2002).

<sup>43</sup> Information obtained via personal communication on February 7, 2003 between K. English of DCJ and Peter Rockwell, senior associate with the Criminal Justice Institute, Inc. and faculty member at the Yale University School of Medicine. Dr. Rockwell, with George De Leon and Alan Bernhardt on behalf of TCA, worked closely on the development and revisions of the prison-based TC standards.

<sup>44</sup> Personal communication between K. English and Peter Rockwell, February 7, 2003.

1. Theoretical Basis
2. Clinical Principles
3. Administration
4. Staffing
5. Facility Environment
6. Program Elements
7. TC Process
8. Stages of Treatment
9. Community TC and Clinical Management
10. Intake Screening and Assessment
11. Community-Based Aftercare

## SECTION FIVE: FINDINGS

**Question 1: Are the components of the CDOC's sex offender therapeutic community grounded in theory and best practices?**

### Component 1. Theoretical and Philosophical Basis

*Program activities must be logically linked to a theoretical foundation. Those activities, then, can be expected to lead to changes in offender behavior.*

According to the TCA standards, "it is essential that programs operating as TCs have a solid grounding in the existing professional literature that describes the TC (history), theory and treatment model" (Therapeutic Communities of America, 1999: 2). Theory provides the fundamental "cause and effect" framework upon which the intervention approach is based. For example, if sexual offending is believed to be the result (at least in part) of the offender's distorted thinking patterns ("the 9 year old was coming on to me," "no means

yes," "it didn't hurt anyone"), then a program would address thinking errors as part of the services it delivers to clients. Program activities must be logically linked to a theoretical foundation. Those activities, then, can be expected to lead to changes in offender behavior.

*SOTMP is guided by the view that consistently holding offenders accountable for their behavior will lead to lifestyle changes that will increase public safety (SOTMP, 2001)*

Further, according to the TCA standards, it is important that therapeutic communities have a philosophy that guides the overall treatment approach. Substance abuse TCs, for example, typically hold the view that substance abuse and criminality are symptoms of a disorder of the whole person, while the SOTMP is guided by the view that consistently holding offenders accountable for their behavior will lead to lifestyle changes that will increase public safety (SOTMP, 2001). TCA Standards T1 and T3<sup>45</sup> state that each program should address its views regarding the disorder, the offender, recovery, and

"right living." The program handbook or manual should provide a section on these views, as well as a statement of the program philosophy.

***FINDING: The SOTMP TC has documented its philosophical and theoretical foundations, grounded in research, in its Program Manual and its Resource Guide.***

*Interview data reflect that staff has a clear vision of the primary goal of the TC: maintaining public safety, and teaching offenders various skills to achieve this goal.*

The TC's program manual provides information regarding the program goals, structure, and treatment for sex offenders. The philosophy of the TC is clearly outlined in the program manual, as is the philosophy statement for inmates<sup>46</sup>. Inmates recite the philosophy statement at the closing of some meetings. Interview data reflect that staff is

<sup>45</sup> A copy of the TCA Standards can be found on the Office of National Drug Control Policy website at [http://www.whitehousedrugpolicy.gov/national\\_assembly/publications/therap\\_comm/ther\\_9.htm](http://www.whitehousedrugpolicy.gov/national_assembly/publications/therap_comm/ther_9.htm)

<sup>46</sup> "Acknowledging that our dysfunctional lifestyles have brought us to this crossroads in our lives, we have come together voluntarily, committing ourselves to become healthy, productive members of society. With the help and respect of the residents and staff, and the support of a higher power, we will acquire knowledge and wisdom that provides the foundation for rational thinking and decision making...leading us to the road to freedom" (TC Philosophy Statement within the program manual, Volume I, Section B, #5).



given a clear vision of the primary goal of the TC: maintaining public safety, and teaching offenders various skills to achieve this goal.<sup>47</sup> The program manual contains important descriptions of the program's purpose, the treatment model, and all essential program elements. Throughout group observations, we frequently heard offenders mention the personal and program goal of “no more victims” indicating that the public safety aspect of victim protection has been clearly and repeatedly stressed to offenders.

***FINDING: The SOTMP's documented “understanding” of sexual assault can indeed be traced to a theoretical foundation, and the fact that several theories underlie the program philosophy reflects the compliance of the program with best practices and Standards T1 and T3 of the Therapeutic Community Association Standards for prison programs.***

The Sex Offender Treatment and Monitoring Program resource guide (SOTMP, 2001: Part II, Section B) provides the following “Model for Understanding Sex Offenders:”

- Sex offenders avoid internal thoughts of fear, inadequacy, etc., by seeking activity or excitement to shut them out (such as work or sexual assault).
- Sex offenders try to seek activities where they can establish a sense of adequacy and sense of control (such as best worker, high status, control of a relationship, sexual assault).
- Sex offenders' inability to establish a relationship could be fueled by biological issues such as depression, anxiety, obsessive-compulsive disorder, or can be the result of a personality disorder such as narcissism, antisocial, etc. or skills deficits.
- Sex offenders' inability to empathize with others results in self-centeredness and feeling like a victim, which leads to anger, alienation, loneliness, and a sense of entitlement.
- Victim thinking allows the offender to justify victimizing others. Sexual interest/drive or views about sex contribute to why they pick sexual means vs. burglary, etc.

Given this understanding of sex offenders and the necessity of linking theory with program activities, the SOTMP would need to implement program components that addressed errors in thinking, behavior and lifestyle that lead to sexual assault. In fact, the TC program does include components to address each of these areas, and these are thoroughly described in the following findings in this report. In particular, see Component 2, Clinical Principals (pages 50 to 64).

Likewise, the program would need to include an assessment for biological problems and personality disorders, and the accompanying medication and psychological treatment. The program's use of Sex Offense Specific Evaluation and other assessments are described in Component 10, Intake Screening and Assessment pages 95 to 96 of this report).

---

<sup>47</sup> This was consistently reported in staff interviews conducted for this study.

The TC's primary mode of treatment is cognitive behavioral therapy. A long tradition of theoretical development underlies cognitive-behavioral treatment and can be traced to B.F. Skinner's behaviorism and learning theory from Sutherland (1947), Bandura (1973), and Akers (1977). Cognitive psychology is based on theories regarding how offenders develop and process social cognition and social information (Crick and Dodge, 1994). Cornish and Clarke (1986) discuss cognition in terms of offenders as rational decision makers. Herman (1990) presents a theory that sexual assault is embedded in power and control.

*Cognitive-behavioral interventions are based on the psychological principle that thinking leads to behavior, so modifying thoughts, attitudes, reasoning, and problem solving, and helping clients to develop new behaviors, will reduce problematic conduct.*

*The therapeutic approach used in the TC is in compliance with theory and best practice.*

Cognitive-behavioral interventions are based on the psychological principle that thinking leads to behavior, so modifying thoughts, attitudes, reasoning, and problem solving, and helping clients to develop new behaviors, will reduce problematic conduct. Antonowicz and Ross (1994) found that cognitive-behavioral models of treatment were used in successful therapeutic communities. Thus, the therapeutic approach used in the TC is in compliance with theory and best practice.

## Component 2. Clinical Principles

The TCA state the following regarding clinical principles:

*It is essential that program participants identify with the TC and feel a sense of belonging in order to change their patterns of criminality and substance use. There must be a continuous (i.e., 24-hour) atmosphere of constructive confrontation and feedback to individuals and the community as a whole, in order to raise personal awareness of the individual's behavior and attitudes (Therapeutic Communities of America, 1999: 3).*

*Therapeutic communities emphasize the development of pro-social values and reliance on peers as agents of change to provide treatment, increase awareness, accountability, and responsibility, and to foster self-help.*

This standard on clinical principles is supported by the professional literature that requires an effective therapeutic community to be a safe, secure, and therapeutic setting in which men in treatment can build relationships that will promote emotional and cognitive growth. Therapeutic communities emphasize the development of pro-social values and reliance on peers as agents of change to provide treatment, increase awareness, accountability, and responsibility, and to foster self-help (Bouffard and Taxman, 2000; Baker & Price, 1997; De Leon, 2000).

### (1) Structured Community Living and "24/7"

The therapeutic community model comprises specific elements that generally include structured community living to integrate work, education, treatment and other activities in a therapeutic milieu that occurs 24 hours a day, seven days a week (De Leon, 2000).

*The 24/7 milieu reflects the need to change the whole person and his or her lifestyle, and the depth of the change requires ongoing, constant attention and work.*

The TCA notes that in the community, participants should be accountable to each other on a "continuous basis" (Therapeutic Communities of America, 1999: Standard CP6). Within the TC structure, peers are taught the tools to learn how to

hold each other accountable at all times--in group, at work, or on the unit. The 24/7 milieu reflects the need to change the whole person and his or her lifestyle, and the depth of the change requires ongoing, constant attention and work.

***FINDING: In some ways the TC operates as a 24/7 milieu and in others it does not.***

At the time of our evaluation, Colorado's modified sex offender TC was not staffed with treatment personnel in the evenings or weekends. TC therapists typically worked an eight-to-five shift, Monday through Friday, with a few exceptions. This placed the entire responsibility of carrying forth into the community the concepts learned during group on the inmates. While the success of treatment and the TC is ultimately reliant on offenders' internalization of the material learned and the desire to change, they are a group of individuals who have long histories of poor decision-making, poor impulse control, and assaultive behaviors. To effect the cognitive and behavioral changes necessary in many aspects of their lives, ultimately leading to an increase in public safety, a broader plan of coverage may need to be considered.

The TC does, however, have a recreational therapist who works Sunday through Thursday evenings. Recreational therapy offers a music program, basketball and softball teams, board game tournaments, and arts and crafts. These activities structure inmate interaction, and when therapeutic issues surface the recreational therapist uses TC tools to help resolve the issue. If transportation is required for the recreational activity additional staff will attend. Also, since receiving feedback from this evaluation, TC staff has implemented several changes. For example, because the administrative offices are "outside the fence" (geographically separated by a fence) from the units where inmates live and where many group sessions are held, there was little opportunity for impromptu encounters between staff and inmates. Staff will now have office hours on the unit to allow more opportunity for interaction between the therapists and inmates. In addition, the TC has integrated a Thursday evening meeting into the program to process community issues and to strengthen the culture of the community. These two changes should provide more avenues for recognizing the small and large successes of members of the community. Inmates have responded very positively to this change.<sup>48</sup>

Inmates participating in the SOTMP TC are expected to behave according to the TC values regardless of the presence of professional staff, expanding the TC experience beyond the time therapists are present. Further, TC members are expected to work together to resolve problems or record the problems for later attention by a therapist. However, during group observations conducted for this study,<sup>49</sup> we heard many discussions that suggest that the community does not always do an adequate job of monitoring itself (however, it reflects positively on the program that offenders brought this information to process in group). Some of these issues are related to housing the TC within the larger prison system.

---

<sup>48</sup> ORS research staff attended and recorded the discussion that took place during the first Thursday evening meeting on January 30, 2003.

<sup>49</sup> Sixty-seven groups were observed using two ORS researchers for each group.

Data obtained from observations and interviews suggest the following problems that interfere with the actual therapeutic nature of the TC:

- Inmates admitted to viewing television programs that were inappropriate for sex offenders.
- The TC has access to all movies that can be viewed by the general prison population. During our research, these included *Monster's Ball*, *American Pie*, *Vanilla Sky*, *Harry Potter* and other movies that seem inappropriate for the sex offending population.
- Inmates tolerate behaviors in the work environment that would not be tolerated in the group. For example, profanity, discussions that demean women, and aggressive displays of anger occur in the work environment.
- Inmates were uncooperative and defensive with a TC member who was assigned to help monitor TV and movie choices. The monitoring was viewed as an intrusion rather than treatment.
- An offender recounted how, when injured in a kitchen accident, no one came to his aid and some community members laughed.
- Pull-ups<sup>50</sup> are sometimes turned in late (perhaps only after the inmate knows he will be caught, as acknowledged by inmates in group).
- When discussing the inappropriate behaviors of an inmate, several members of the group reported that the behaviors had been occurring for some time. No one had previously reported the behaviors.
- Inmates reported avoiding other inmates with inappropriate behaviors (rather than bringing the inmate treatment).
- Stealing from the kitchen had been occurring for some time, and while other inmates were aware of the problem, no one had issued or received a Pull-up.

***FINDING: Staff disagreed as to whether the community operated 24/7. Most thought that training, integrating, and getting “buy-in” from correctional staff was fundamental to operating as a 24/7 facility.***

Staff offered varying opinions regarding whether the Arrowhead TC could be considered 24/7 treatment. Some were adamant in their assertion that it was not and could not be when therapists leave at 5 p.m. Others mentioned the lack of coordination with non-TC staff such as correctional officers who could support the milieu during evenings and weekends. These staff believed the TC could not be effective until all staff is trained on the TC approach, sold on the idea that this approach will work, and can attend house meetings and be informed of the issues in the community.

*In general, most staff we interviewed support training for correctional staff, integrating them into the program, and the need for “buy in” from correctional staff before the program can be operated as a fully functioning 24/7 program.*

However, other staff stated that the housing officer is considered part of the TC and that some correctional officers hold the offenders accountable by reporting incidents and behaviors. One staff member considered the TC as “very powerful” and stated that the “basis of the TC is the people in it and not the staff. It continues whether they have staff there or not.” In general, however, most staff we interviewed support training for correctional staff, integrating them into the

<sup>50</sup> “Pull-ups of Awareness” is a tool used in TC environments. Inmates are expected to “pull-up” each other on all irresponsible behaviors.

program, and the need for “buy in” from correctional staff before the program can be operated as a fully functioning 24/7 program.

***FINDING: Inmates agreed that the community operated 24 hours a day, seven days a week, and that inmates provided treatment to each other in many ways.***

Some inmates who participated in focus groups told us that they were more likely to depend on each other than therapists for support. Inmates stated that since therapists are only available during normal working hours, “on the weekends, the brothers do [the] TC.” They felt treatment occurred all the time. One inmate said, “You get more support and positive encouragement from the brothers than you are going to get from the therapists.” Another stated, “I think there is more treatment going on in the house over there, than ...in the groups...talking to each other, just sitting in a room, sitting at a table, playing cards, talking over a game of cards, watching a baseball game, walking the yard...”

***FINDING: Some inmates revealed, perhaps inadvertently, that they were not working the program.***

In focus groups with the members of the TC community, some inmates noted that it was easier to be honest with each other than therapists. Several inmates mentioned that they were able to relate to each other in ways that the therapists couldn’t because the therapists had never committed a sex offense. As one inmate stated, “we know each other, we know what we’ve done. We have similarities there that are so pronounced. We might have done different crimes but we have all done them the same way.” This theme was present throughout all four of the focus groups because inmates feel like they, “know more about each other than anybody else is going to know and we know that this person needs help and we are willing to help him.” Helping other inmates sometimes translated into protecting their “brothers” by not reporting incidents that are against the rules. Some inmates admitted not reporting things because they did not want to see their brothers get terminated. As one inmate commented, “A lot of stuff gets put to the side because someone is on thin ice already. I don’t want to see him be terminated.” Several other inmates made similar comments regarding feelings surrounding terminations. One stated he wished they (therapists) would, “Let us work on the issues. We’re his brothers; give us a chance to work with him. Don’t just throw him away. He’s been thrown away all his life.” But termination from the TC is based on behavior described in the treatment contract. Many offenders seemed to see themselves and each other as victims.

## *(2) Community as the Method of Intervention*

The TCA states that the primary approach to treatment should be “community-as-method” and that “participants are accountable to each other and the community on a continuous basis, fostering a strong sense of responsibility for self and others” (Therapeutic Communities of America, 1999: Standards CP1 and CP4).

***FINDING: The structure of the TC is designed to facilitate community living. The concept of TC community living has been appropriately modified to address the special issues of sex offenders.***

According to the therapeutic community program manual the structure of the TC is designed to facilitate “community living” so the inmate can develop a healthier lifestyle

*TC inmates sign a contract agreeing to treat other participants with respect and dignity, to be considerate of others and conduct themselves appropriately.*

wherein he is his “brother’s keeper” rather than being self centered or individualistic (Therapeutic Community Program Manual, Volume I: Section B, #2). TC inmates sign a contract agreeing to treat other participants with respect and dignity, to be considerate of others and conduct themselves appropriately.<sup>51</sup> As one therapist remarked, “peers are the agents for therapy.”

The TC for sex offenders at Arrowhead has been modified from the traditional drug and alcohol TC model to address sex offense specific problems. The TC contains several components of a generic TC program model (De Leon, 2000), including community environment, peers as role models, a structured day, a phase format, and community activities. However, modifications have been made to more appropriately serve the sex offender population. Sex offenders typically have problems relating to the inappropriate wielding of power and control of other individuals. They need to learn to develop peer relationships where they do not have power over the members of their community. Therefore, the community is structured such that offenders have equal power relationships rather than hierarchical relationships (as in drug and alcohol TCs) as they progress through treatment.<sup>52</sup> The program also does not hire graduated members of the community as staff, a common feature of substance abuse programs, but instead uses professional therapists to provide cognitive behavioral sex offender treatment groups to address sex offense issues.

*Sex offenders need to learn to develop peer relationships where they do not have power over the members of their community.*

***FINDING: Daily staff meetings enhance communication among therapists and provide opportunities for follow ups and updates on offenders.***

Since the TC emphasizes accountability in daily life, it is important that all staff is aware of the issues of the community members so they can respond immediately when problems surface. During interviews, therapists reported that staff meetings were an effective method of keeping team members informed and updated. Daily staff meetings provide opportunities to discuss issues pertaining to specific offenders, including the results of polygraphs, announcements, and group updates. We witnessed numerous staff meetings where inmate issues were reviewed by staff who then engaged in brainstorming sessions to solve problems. We found that general information, such as recent court decisions and criteria for parole, and non-TC staff issues were important topics also discussed at staff meetings.

***FINDING: TC inmates are expected to support the treatment efforts of their brothers. Two of these--pull-ups and requests for group--are used regularly and appear to be effective ways for inmates to monitor each other’s behaviors and express concerns. Further, while the pull-up system is not perfect, almost all inmates we spoke with agreed that it works and is essential to treatment.***

TC inmates are expected to support the treatment efforts of their brothers by giving them “Pull-ups of Awareness” and logging “Requests for Group” (RFG) when their behavior is problematic. Inmates are expected to “pull-up” each other on all irresponsible behaviors regardless of the level of importance of a particular behavior. Pull-ups cover a large

<sup>51</sup> See Appendix I for a copy of the contract.

<sup>52</sup> Colorado Department of Corrections Program Summary (from the 50-state survey, 2000, p. 45).

range of behavior from forgetting one's glasses during a group session (where they may need to read) to acquiring pornography. The idea is to encourage offenders to be extremely aware of all their behaviors, even seemingly unimportant ones. Pull-ups are used to increase inmate awareness regarding all facets of life.

Requests for Group (RFGs) are used as a tool to encourage inmates to examine their behaviors and to discuss concerns. It was common for therapists to stress that inmates "hold each other accountable" as a way of being "his brother's keeper." This statement was consistently made and often recorded during our observations of treatment groups, reflecting the emphasis given to this aspect of community life.

Indeed, inmates appeared to be using the pull-up and RFG system. There were far more RFGs reported than could ever be addressed by staff. When asked how these numerous RFGs were managed, we were told that requests are prioritized based on seriousness of the issues. Also, issues that have broad application to many offenders are most likely to be selected for discussion, according to interviews with staff. Some RFGs are referred to other groups, typically Rational Office,<sup>53</sup> or to the primary therapist. Sometimes RFGs with similar themes are combined and addressed, and other times a learning experience (e.g., homework or paper) may be assigned to RFGs that are not addressed in the group setting.

*Indeed, inmates appeared to be using the pull-up and RFG system.*

During our group observations, we found that RFGs were typically addressed in a manner that provides treatment and education to all group members. Therapists tended to ask for clarification regarding the RFG and explore the inmate(s) perception and intentions regarding the event. Group members sometimes added their perceptions, problem-solved and examined the criminal thinking errors that precipitated or were used during the event and then provided feedback. It was common for group members to relate the criminal thinking errors and tactics described to their own behaviors. Addressing the RFG in this way permitted all group members to experience some benefit from the RFG, if they chose to do so.

*During our group observations, we found that RFGs were typically addressed in a manner that provides treatment and education to all group members.*

We found that far more "pull-ups" were reported than could be addressed in a timely way. For instance, it was not unusual to hear pull-ups, read during Concept group, which occurred a month or more before it was addressed. However, the majority of inmates we spoke with during the focus groups agreed that the pull-up system works and is essential to treatment. A few inmates reported that although sometimes the pull-up system was used in "retaliation," it is generally an effective system for raising awareness and changing behaviors. For example, an inmate stated that, "there have been a few cases of abuse of the (pull-up) system by certain aggressive people where they don't want to look at what they are doing. They want to look at what other people are doing. They use [it] to get people back, to get their power back... but the benefits far outweigh the small amount of acting out." Inmates throughout all four focus groups mentioned several benefits of the pull-up system. One inmate noted, "They call them pull-ups of awareness

<sup>53</sup> Rational Office is a committee made up of 3 inmates and 1 therapist who meet twice a week. The purpose is to help TC members understand behaviors associated with pull-ups. The committee determines consequences and learning experiences for such behaviors as flagrant violation of rules, excessive number of pull-ups, or lack of involvement in the pull-up process.

*"It makes me look at my behavior and it also helps me to accept the fact that it is okay for people to look at me and tell me that I am doing something that I shouldn't be doing. That it's their perception of me, and it could be right. It slows me down long enough to think that maybe somebody else has a different perception of me than what I see myself. In that way, I think it works."*

for a reason. As a rule and as a group of people in society, we are very unaware. The only thing we are aware of is how we want to feel...." Another stated, "It makes me look at my behavior and it also helps me to accept the fact that it is okay for people to look at me and tell me that I am doing something that I shouldn't be doing.

That it's their perception of me, and it could be right. It slows me down long enough to think that maybe somebody else has a different perception of me than what I see myself. In that way, I think it works." And from another, "you can't see everything and we're the mirrors."

***FINDING: Few members reach commitment level, thus there are few opportunities to implement the "big brother" concept.***

Members at the Commitment Level were asked to become big brothers to new TC members and to members who were placed on TC "probation".<sup>54</sup> Big brothers are assigned to help orient new members to the TC and assist new members (and members on programmatic probation) with assignments and learning experiences. Unfortunately, few members reach commitment level. The program recently modified its requirements and uses TC members as big brothers if they have completed Basic Orientation Training<sup>55</sup> group.

**(3) Group Therapy and the Clinical Principal of Community as the Primary Agent of Change**

The findings in this section as well as those that describe group process measures later in this report<sup>56</sup> are based on observations of 67 therapy groups held from March 25, 2002 to June 20, 2002. We selected certain weeks for our observations, as resources did not permit us to observe every group conducted in this time frame. Two researchers usually observed each group. Afterwards, the two observers conferred and rated each group according to a "Group Process Measure" instrument. While we used this instrument to structure our observations of the group process, the observations were intended as a strictly qualitative method to gather information about service delivery in the TC. Table 5 on the next page presents a list and brief descriptions of the groups we observed.

<sup>54</sup> TC program manual, Volume I: Section B, #14.

<sup>55</sup> BOT is the first group the inmate attends. Inmates learn to identify criminal thinking errors (e.g., victim stance, lack of trust, and failure to assume responsible initiatives), tactics (which represent behaviors that may be disruptive to treatment), and foundation thinking errors (the inmates' value system).

<sup>56</sup> Findings on group process are found in Component 6, Program Elements, (4) Group Therapy, p. 85 to 88.



**Table 5: Groups Observed**

| <b>Group Name</b>                         | <b>Brief Description</b>   | <b># Observations</b> |
|---|--|-----------------------|
| Anger Management                          | As the name suggests, this group examines issues related to the identification of circumstances that result in feelings of anger and the appropriate management and expression of these feelings.  | 3                     |
| Basic Orientation Training (BOT)          | BOT is the first group the inmate attends. Inmates learn to identify criminal thinking errors (CTEs) (e.g., victim stance, lack of trust, and failure to assume responsible initiatives), tactics (which represent behaviors that may be disruptive to treatment), and foundation thinking errors (FTEs) (the inmates' value system).  | 8                     |
| Concept Group                             | Offenders are always in a concept group regardless of level. This is a confrontational group that addresses a variety of inmate issues, including those in RFGs (Requests for Group). Using a technique developed by Jan Hindman, cards labeled with CTEs, Tactics and FTEs are laid on the floor. As a group member describes an issue or problem, other inmates pick a card that relates to the issues and address how the CTE, Tactic or FTE applies to their own behavior and to the issue or problem at hand. | 17(*)                 |
| Covert Sensitization                      | The group explores a cognitive behavioral treatment designed to change unwanted behavior by changing the thoughts and feelings that accompany the unwanted behavior.   | 4                     |
| Crossover/ Kitchen Group                  | Since sex offender and drug and alcohol therapeutic members may work together, this group is used to discuss issues that occur in their work environments.   | 3                     |
| Cycle Group                               | Offenders must present their cycles of abuse that cover their entire life span of sexual deviant behavior.   | 8                     |
| Integrated Group                          | This group is composed of inmates who are developmentally disabled and are in Phase 1 of the program. They are not yet part of the therapeutic community. (However, they do live and work with them as well as attend a Concept Group.)  | 1                     |
| Interpersonal Communication Skills (IPCS) | The focus of this group is on communication and provides an additional opportunity to address a variety of inmate issues.  | 4                     |
| Journaling II                             | Offenders describe their thoughts, feelings, body sensations, fantasies and behaviors associated with a particular event.  | 2                     |
| Personal Change Contract (PCC)            | Offenders usually attend this group within six months of parole eligibility or when Commitment Level is reached. (Since our evaluation the schedule has been changed so that inmates attend PCC while they are in the in the (Orientation) Change level.) Offenders discuss their individual relapse prevention plans, cycles of abuse, support systems, and begin to develop Personal Change Contracts. <sup>57</sup>   | 7                     |

<sup>57</sup> See Appendix J for a copy of contents of the Personal Change Contract.

|                                  |  |           |
|----------------------------------|--|-----------|
| Probation Group                  | This group is for those inmates who have been placed on probation for lack of progress. In this group they will work on their issues that are holding them back in treatment.  | 1         |
| Rational Office                  | A committee made up of 3 inmates and 1 therapist who meet twice a week. The purpose is to help TC members understand behaviors associated with pull-ups. The committee determines consequences and learning experiences for such behaviors as flagrant violations of rules, excessive number of pull-ups, or lack of involvement in the pull-up process. | 1         |
| Rational Behavior Training (RBT) | Offenders complete Rational Self Analysis worksheets and describe an event and determine if it is “camera checkable.” They describe feelings and behaviors associated with the event, and determine and develop rational alternatives to their initial perceptions. <sup>58</sup>  | 4         |
| Relapse Rehearsal                | Offenders role-play risk situations to determine if they can put their individual safety plans into effect.  | 3         |
| Victim Impact                    | This group viewed a video that described the impact of certain crimes on victims. The group was held once during our observation period and was then eliminated due to funding constraints.  | 1         |
| <b>Total Groups Observed</b>     |  | <b>67</b> |

(\* ) Concept group was offered most frequently because everyone (regardless of treatment level) has to take it. For this reason, Concept group was observed most often.

#### (a) Group Therapy

The literature recommends multiple approaches to sex offender treatment (Marshall, Laws, and Barbaree, 1990). ATSA (2001) and the Colorado Sex Offender Management Board (1999) *Standards and Guidelines* list several key components of sound treatment practices including relapse prevention, cognitive restructuring, sexual arousal control, interpersonal skills, and victim awareness and empathy. Groups are the preferred method of delivering treatment to sex offenders (although the rationale for group therapy is clinical rather than empirical).<sup>59</sup> Groups can be used to deliver many of the key components of treatment,<sup>60</sup> and should focus on developing victim empathy, cognitive restructuring,<sup>61</sup> daily management skills, and sex education (Lowe, 2001). Successful programs for sex offenders generally are based on cognitive behavioral principles and

<sup>58</sup> See Appendix K for a copy of an RSA.

<sup>59</sup> Group therapy provides the best format for offenders to observe others making mistakes and trying to cope. It also allows offenders to be confronted on a continuous basis. “Individual therapy allows the offender too much opportunity to manage his image” (Knapp, 1996, p. 13.5).

<sup>60</sup> Key components of treatment include cognitive and behavioral therapies, interpersonal relationships and social skills, victim empathy, relapse prevention skills, and marital and family therapy (ATSA, 2001).

<sup>61</sup> Cognitive restructuring teaches offenders to identify, analyze, challenge and change specific distortions, irrational beliefs and thinking errors to be rational and realistic. Common approaches include Rational Emotive Therapy cognitive/ behavioral therapy, teaching and explanation by therapists, group intervention, journaling techniques, life histories and identification of distorted thoughts in fantasies.

use some adaptation of the relapse prevention model<sup>62</sup> (Peebles, 1999; Marshall and Williams, 1998). Similar to the relapse prevention model, the sexual assault cycle model teaches offenders to understand their cycle of offending, to identify where they are in their cycle, and learn appropriate interventions (Carich, Gray, Rombouts, Stone & Pithers, 2001). Group sessions focus on encouraging offenders to take responsibility for their abusive behaviors (Loss, 2001; Marshall, 1994), cognitive restructuring (Lowe, 2001) and developing empathy (Loss, 2001, Hildebrand and Pithers, 1989, Marshall and Williams, 1998; Lowe, 2001).

***FINDING: A multifaceted approach to treatment is accomplished by providing a variety of group treatment interventions.***

As Table 5 above shows, a large number of diverse groups were held each week. These groups represented a multifaceted approach to treatment programming.<sup>63</sup> A review of Table 5 above also shows that the topics covered are those recommended in the literature. The treatment manual for the TC provides a syllabus for each group that specifies a group structure for the therapists to follow.

***FINDING: Groups are the primary means of providing treatment in the TC.***

In therapeutic communities, it is usually understood that the community is the method of intervention. But in the SOTMP group treatment is the primary method of intervention. As noted above, the treatment literature suggests that group therapy, with a focus on relapse prevention, is the preferred approach for working with sex offenders (Marshall and Williams, 1998; Mussack & Carrich, 2001; Loss, 2001).

We found that the material discussed in group therapy, along with the homework assignments inmates were expected to complete, covered the expected range of topics suggested by the literature. The approaches used were cognitive-behavioral and educational, with an emphasis on building skills.

#### *(b) Group Participation*

According to the TCA, the therapeutic community should provide a “culture defined by a self-help attitude where community members confront each other’s negative behavior and attitudes and establish...an environment where disclosure is encouraged” (Therapeutic Communities of America, 1999: 3). TCA Standard CP4 states that offenders should be aware of each other’s treatment goals and help each other achieve those goals. According to Standard CP5, experiential learning, that is *doing* rather than *getting* therapy, should be emphasized. And Standard CP8 directs that “[A] major focus of participant learning is the development of affective skills, including the ability to identify and express feelings in a pro-social manner” (Therapeutic Communities of America, 1999: 3).

---

<sup>62</sup> Relapse prevention is based on the principle that progression toward offending can be disrupted if offenders can identify their thoughts and behaviors before they offend and use coping strategies to intervene. Goals of relapse prevention include identifying risk factors, developing methods of self-monitoring, executing specific interventions and educating the offender’s support system on the relapse prevention plan (Carich et al., 2001).

<sup>63</sup> See Phases of Treatment on p. 93 Table 6.

***FINDING: Most groups had high levels of participation, and offenders were confronted on their thinking errors and inappropriate behaviors.***

Most of the group sessions we observed had high levels of inmate participation and members processed issues well, reflecting a level of understanding that could increase treatment efficacy. Therapists frequently made good efforts to ensure that all group members were included in the discussions. There were many instances where therapists took special care to ensure that group members understood the concepts being discussed. There were a few instances when concepts were not defined well, and it appeared that offenders had trouble understanding and following the discussion.

Therapists and group members often related an inmate's behavior regarding an issue to his specific pattern of behaviors and/or cognitive distortions. We observed that most therapists were familiar with many of the individual issues of each offender, and their feedback could be tied into a wider range of inmate issues. This was true for offender-to-offender feedback as well. Offenders providing feedback sometimes linked their comments to a broader pattern of behaviors of the person receiving feedback. When confronting another inmate, group members frequently used personal examples to provide insight on how they handled an issue or how they experienced a similar problem. This approach allowed inmates to confront each other but remain empathic. While empathy and concern were frequently demonstrated, this did not appear to interfere with the ability of group members to challenge each other. We saw many examples where inmates questioned other group members rigorously while the inmate being addressed remained defensive or non-responsive to the intervention, yet the group continued to try to "get through" to the inmate. We also observed several examples of therapists confronting inmates who conducted side conversations or laughed inappropriately. Efforts to challenge and confront did not occur over every issue in every group, but this method of group process was the rule rather than the exception.

*Much of the group work was intense and focused on the serious and complex work of confronting distorted thinking patterns and behaviors.*

Much of the group work was intense and focused on the serious and complex work of confronting distorted thinking patterns and behaviors. For example, the Cycle group examined intimate details of offender abuse patterns. Group members often offered helpful, positive, and insightful feedback. Researchers frequently observed appropriate confrontations by therapists and offenders when a group member displayed thinking errors while presenting his cycle. Efforts were made to address these errors, and offenders typically identified the error in a way that related to their own cycles.

***FINDING: Treatment activities emphasized "doing, rather than getting" therapy, and inmate participation played a major role in providing treatment through the group process.***

We found through our observations that offenders had opportunities to "do" therapy throughout most of the groups and their participation played a major role in bringing each other treatment through the group process. Members were expected to actively listen and provide appropriate feedback. Groups also provided an opportunity for offenders to become aware of each others treatment needs. During group sessions, personal introductions and offense disclosures were an important component of ongoing treatment, and this is how group therapy should be operating according to Loss (2001).

Many examples illustrated that inmates had opportunities to learn and integrate treatment concepts through practice. In the Interpersonal Communication Skills (IPCS) group, inmates enhanced listening skills by role playing and other exercises. The Personal Change Contract Rehearsal group offered inmates the opportunity to role-play situations, allowing them to practice their safety plans. During Cycle group, inmates presented segments of their cycle and were challenged to re-examine areas that were inadequately described. They were then assigned to re-write sections of their cycles to reflect more personal accountability and responsibility. In the Covert Sensitization groups, inmates wrote scenes that progressed them towards deviant arousal. They then developed a scene to create an adverse reaction to the arousal. They were instructed to describe an aversive scene that was painful to them (such as getting arrested in front of family members). Inmates were instructed to link the aversive scene to the arousal scene so that, ultimately, the arousal scene might also become painful to them. Inmates presented these scenes to the group and received feedback. Inmates were assigned to revise these scenes until the group deemed them appropriate and useful.

***FINDING: In most cases, participants appeared to understand the concepts related to sex offending behaviors, as indicated by the quality of feedback and input offered when confronting each other.***

As discussed earlier in this report, members of the TC are required to successfully complete Phase I of the SOTMP before participating in the therapeutic community. Basic concepts about sex offending behaviors are introduced in Phase I. Inmates learn about Criminal Thinking Errors (CTEs),<sup>64</sup> Foundation Thinking Errors (FTEs)<sup>65</sup> and Tactics Obstructing Effective Treatment (Tactics)<sup>66</sup> early in Phase II. We observed that inmates who participated in “advanced” groups, such as those that explore and discuss individual deviant and offending cycles, appeared to have the background necessary to identify more complex issues and sex offending behaviors. Inmates were familiar with terminology and could recognize thinking errors and tactics.<sup>67</sup> While we did observe some instances where inmates could have benefited from more explanation, offenders were generally well grounded in the basic concepts associated with sex offending behaviors.

*Offenders were generally well grounded in the basic concepts associated with sex offending behaviors.*

***FINDING: The role of the group in providing support is evident.***

The work of confronting the deviant behavior and thinking patterns in sexual offending is difficult, yet it occurred at some level in almost all the groups we observed. The Cycle

---

<sup>64</sup> Criminal Thinking Errors were developed by Yochelson and Samenow and describe the characteristics of criminal thinking (e.g., anger, criminal pride, concrete thinking and 35 others).

<sup>65</sup> The program discusses eight Foundation Thinking Errors that include: self-centeredness, power and control, power and control continuum, power pendulum, victim stance, anger, concrete thinking and criminal sentimentality. Some of these overlap with CTEs and describe characteristics of criminal thinking.

<sup>66</sup> Tactics to obstructing effective treatment include behaviors that criminals pursue to create a barrier to treatment. Such things as lying, vagueness (in description of their behaviors), and minimizing the offense are included here.

<sup>67</sup> In fact, when we conducted a focus group with parole officers responsible for supervising sex offenders in the community, they stated that their wish was that all sex offenders be required to receive some type of sex offender treatment before entering the community. Sex offenders who have received treatment have some knowledge of the issues the parole officers must address, otherwise, these officers must “start from scratch.”

group<sup>68</sup> encourages offenders to “share their secrets.” These groups were among the highest in level of participation and intensity. Inmates in a focus group commented that Cycle is the most difficult group because “all aspects of your life are examined and all secrets are exposed.” One offender said that it is an opportunity for offenders to feel like “they are not alone.” Because of this process of opening up, a level of group cohesiveness may develop. One researcher described sensing a “deep connection among the [members of the] group.”

We observed many instances where both therapists and inmates provided positive feedback and support when group members admitted responsibility or acknowledged difficulties. The offenders take the role of helping each other in treatment seriously, demonstrated by one inmate who commented that he felt a personal sense of failure when another offender was terminated from treatment because he had missed opportunities to deliver treatment to that offender.

### *(c) The Role of the Therapist in Groups*

According to the TCA, staff is seen as members of the community but with different roles than the offenders, and while staff maintains the ultimate authority, the focus of control is shared between staff and inmates. The Standards note that in addition to formal interactions with inmates, counselors also serve as role models (Therapeutic Communities of America, 1999: Standards CP3, CP7 and CP9).

According to De Leon (2000) staff plays different roles in different groups. These roles can include serving as facilitators, teachers, guides, managers, and therapists depending on the type of group. Nevertheless, all groups are facilitated in a way that encourages peers to help each other in the process of self-change. “Regardless of the facilitator, the actual group process involves peers interacting, sharing, suggesting, instructing, and confronting each other” (De Leon, 2000 p. 272).

### ***FINDING: The majority of the time, TC therapists modeled pro-social attitudes and behaviors, and confrontations were carried out firmly but respectfully.***

In the majority of the groups we observed, therapists effectively role modeled pro-social interaction and desirable communication skills. Often, therapists were familiar with each offender’s issues, and this enhanced their level of feedback. Therapists addressed offenders by name, usually using the “mister” prefix. We observed one therapist make a particular effort to memorize a new group member’s name by saying it several times reinforcing this with a rhyme to ensure the name was remembered. There were a few instances, however, where it was clear that the therapist was not familiar with group participants. This usually occurred when the therapist was returning from time off or there was a change in therapists leading the group.

---

<sup>68</sup> Recent changes in the program seem to have enhanced this aspect of treatment. Previously, a single offender would present his entire cycle and then get feedback. Because it could take months for this person to finish his cycle it became obvious that this method was delaying the progression of other group members. Currently, each member of the group presents a part of his cycle. Each man then reads his cycle while other members of the group take notes. When he is done, group members give him feedback. Then the next man presents the same section. Once everyone is done with that section, the group moves onto the next section.

While some therapists modeled the concept of accepting responsibility for one's actions by openly acknowledging small errors (such as forgetting copies of promised material), we also observed some missed opportunities to model this behavior.

Most of the time therapists communicated calmly but firmly to inmates. But in some instances, a therapist "lectured" the group, and this approach seemed to diminish participation and promote a sense of despair among inmates. While this occurred rarely, the impact on the inmates appeared to be significant.

Therapists usually helped offenders address issues in positive ways. For instance, a difficulty was sometimes reframed as an opportunity, and small treatment gains were acknowledged. Sometimes the TC staff used humor, always in an appropriate manner, and this approach seemed well received by inmates. The use of humor at appropriate times in the group seemed to build rapport and "humanize" the situation.

We found differences in communication styles between sex offender therapists and drug and alcohol therapists who shared facilitation responsibilities for Kitchen and Crossover groups. One drug and alcohol therapist laughed at some inmates and communicated in the language patterns of the inmates, using slang and inappropriate grammar (but not profanity). This behavior was an attempt to confront the inmate, but it did not exemplify positive role modeling according to the sex offender program plan. This approach to confrontation was quite different than that used by the sex offender therapists and may point to philosophical differences between the two programs. These differing approaches may send confusing messages to offenders.

***FINDING: Therapists generally made good efforts to respond to offender questions and provide clarification, but some opportunities to provide inmates information were missed.***

Some therapists appeared to be quite in tune with the inmate's learning style and offered feedback in a way that was easily comprehensible for individual offenders. For instance, we observed a therapist dismantle a thinking error into pieces so the offender could better understand the concept.

There were a few occasions, however, when opportunities for deeper understanding were missed. For example, there were times when we noticed that an offender did not appear to understand a concept or issue, and further clarification was not provided. In some instances, inmates asked for clarification, but remained confused after the answer was provided. In some cases the group simply "moved on." A few times the therapist did not respond even after being directly asked questions by inmates. This was more likely to happen when a therapist engaged in a "lecturing" mode, and the group was primarily didactic rather than process oriented. We also observed some instances where the therapist stated that questions would be addressed at a later time, yet the group was dismissed without questions being answered. In one group a video was presented but there was not enough time to discuss it.

***FINDING: In a few group sessions, the effort by the therapist to present material to the group appeared to outweigh the importance of inmates learning the concepts.***

The Anger Management groups we observed used a didactic approach to present concepts. The therapist presented ideas, and these were accompanied by a formal exercise (such as requiring offenders to describe aggressive, passive or assertive qualities in a scene). Offenders took notes and were sometimes asked to take turns reading the presentation material. Because there was generally less discussion in these groups, it was difficult to determine whether all offenders were able to understand the concepts presented. The emphasis appeared to be getting through the material rather than ensuring that the offenders were digesting the concepts. For instance, one researcher noted that offenders were “frantically” taking notes, but the presenter did not pause to let the group catch up or ask questions. We were left with the impression that too much material may have been delivered too quickly for group members to successfully absorb the information.

***FINDING: Most of the TC therapists were very skilled at group facilitation; however, some variation was observed that suggests the need for additional training or supervision.***

Generally, therapists were quite skilled at facilitating input from the entire group, and creating or ensuring opportunities for group members to work on their issues. Most therapists were able to develop an obvious rapport with inmates, and mutual respect was evident. We observed many examples when therapists were able to successfully refocus the group when they began to veer from the central point of discussion. However, sometimes group members could not provide and obtain input because not enough time was available, because the group was dismissed or the therapist moved on to the next issue. Occasionally, one group member monopolized the discussion, and the therapist team made only weak efforts to draw in other members. We also observed a few instances where groups seemed to be facilitated mainly by one of the therapists, while the other participated minimally or not at all. Occasionally inmates had to explain the group process and activities to a therapist (usually because of a change in therapists or someone filling in), and this seemed to be an inefficient use of group time.

### **Component 3. Administration**

#### **(1) General Administrative Support**

The TCA Standards note that it is necessary that key DOC administrative and management staff who work with the program have a complete understanding of the TC. All TC staff, including administrative and support staff, are part of the community and therefore need to fully support the principles and practices of the TC process (Therapeutic Communities of America, 1999: 5).



***FINDING: Administrators and staff generally agree that the goals and philosophy of the Sex Offender Therapeutic Community integrate with the philosophy of the Colorado Department of Corrections. However, the program is not strongly supported by correctional administrators.***

Many of the TC and the DOC administrative staff who participated in this study voiced great concern with improving public safety and providing a secure environment for inmates. Both TC and the DOC staff expressed a commitment to the successful reintegration of inmates into the community. Both staff and administrators were clear that the primary goals of the TC include community safety and reducing the likelihood of re-offense.

While two of the seven administrators we interviewed expressed support for the TC, others questioned the value of the program. These individuals expressed a concern about program cost, and one questioned whether the TC was "legitimate" or simply "makes inmates better criminals." Some administrators viewed treatment as "coddling" the inmates. Some valued the program primarily because it keeps inmates occupied and makes inmates easier to manage.

***FINDING: The conflict between addressing individual offender needs and the correctional approach of treating all inmates equally may undermine the program. Continually requiring the program to justify its existence takes resources away from the delivery of services and programmatic quality control.***

While addressing individual needs is important from a clinical perspective, the correctional method to managing inmates depends on an environment that treats all inmates equally, according to interview data. This discrepancy appears to be an important area of conflict because it may undermine the program in very specific ways. The conflict manifests itself by pressuring TC professionals to provide continual and repeated justification of the program. This situation requires staff to spend many, many hours addressing administrative concerns rather than focusing on the program operations and implementing new ideas. When asked how the support or lack of support of the administration (DOC and Arrowhead Correctional Center) impacts their work, as one person stated the "energy it takes to convince others of the program's validity" and "increased stress" to justify treatment for sex offenders negatively affected the program. Three out of 10 staff that completed survey questionnaires for this study noted that the lack of support from ACC had the "most" (negative) impact on their jobs. When responding to questions on the staff survey regarding barriers to implementation of the TC program, the most frequently mentioned issue (4 out of 10 responses) was the lack of support from ACC administrators.

Several staff also remarked (during interviews and comments on the survey questionnaire) that administration was not well-informed regarding sex offender treatment. They mentioned the lack of TC training and orientation to correctional staff as well as the administration. The extent to which this lack of information and understanding about the program is tied to administrative concerns over program efficiency is unknown.

Despite the consistency between the overall DOC and TC goals, the lack of unified support for the TC by DOC management has important consequences for the inmates and the program. While we were conducting this evaluation, for example, a DOC staff

member from the Arrowhead Correctional Center warden's office was also tasked with "evaluating" the TC.<sup>69</sup> TC staff reported that some of the information contained in the evaluation material was incorrect, and remained so even after efforts were made to correct the misinformation.<sup>70</sup> We also learned that repeated requests for information from program staff for the purpose of this in-house evaluation—often for information that had previously been provided—took important time away from the SOTMP.<sup>71</sup>

*We observed TC therapists to have extremely full schedules, sometimes literally running from one activity to another.*

A lack of support from the prison administration is also reflected in the conversion of therapist positions into other roles. Although TC administrators sometimes initiated these changes, the impact on the program remains a concern. A therapist position became a research position dedicated to studying the SOTMP as a way to enhance quality control of the program and provide information to those who questioned aspects of the program. The research position was moved under the authority of another division in the prison, resulting in conflicting task priorities. Likewise, the conversion of a therapist position into an Arrowhead work supervisor for the TC was accomplished to ensure continuity between the TC and the inmate work environment, but the position was converted at the expense of service delivery to offenders. We observed TC therapists to have extremely full schedules, sometimes literally running from one activity to another. The program is clearly minimally staffed to provide the required services. Decreasing the size of the treatment team in exchange for collateral positions that may not be completely dedicated to the operation of the SOTMP reflects an overall lack of support for the SOTMP program. It seems reasonable to assume that when the attention of staff and inmates is continually and sometimes permanently diverted from the TC, over time the program may become less cohesive. Ultimately, the effectiveness of the program may suffer and this translates into reduced public safety.

## (2) Adequate Funding

Baker and Price (1997) note that adequate funding is a crucial organizational support for a therapeutic community. Likewise, the TCA states that "...sufficient financial support and resources [are necessary] to enable [the program] to maintain the integrity and autonomy of the therapeutic community process while insuring safe integration into the prison process" (Therapeutic Communities of America, 1999: Standard AD10).

---

<sup>69</sup> As part of this activity, the staff person interviewed DCJ's Director of Research. He then forwarded the research director a packet of his findings.

<sup>70</sup> The DCJ research director also had this experience.

<sup>71</sup> It was not our objective to study the impact or the quality of DOC's evaluation of the SOTMP. However, since the activity occurred during our evaluation, our observations are included here.

**FINDING: Current funding for the SOTMP program (including the therapeutic community) indicates that the cost of this program is \$2,613,241.<sup>72 73</sup> While the need for sex offender treatment in prison is high, the SOTMP program represents approximately .049 percent of the Colorado Department of Corrections general fund budget request of \$532,753,788 for FY2003-04.<sup>74</sup>**

According to the SOTMP, the Colorado Department of Corrections has under its jurisdiction “about 4,000 identified sex offenders. Approximately 95% of these sex offenders will be released back into the community” (SOTMP, 2001, Fact Sheet). According to this document, “With incarceration alone, most sex offenders will be [at a] higher risk to re-offend when released.” In fact, this statement has also been substantiated by the outcome results in this report that show that sex offenders released from prison without treatment are more likely to re-offend.<sup>75</sup> As of the beginning of 2000, the population of identified incarcerated sex offenders amounts to approximately 24 percent of the adult incarcerated population.<sup>76</sup> Clearly, the need for services to treat sex offenders is very high. According to current figures, the entire SOTMP program costs \$2,613,241 per year, constituting about one half of one percent of the DOC budget. This figure not only includes costs directly related to treatment but also includes non-treatment costs. The SOTMP program costs cover: group therapy (760 inmates per year), supplemental individual therapy, polygraph testing (135 exams per year); identification of sex offenders at the Denver Reception and Diagnostic Center (DRDC) (1,170 offenders per year); administrative review preparation and participation per the Chambers decision<sup>77</sup> screening an estimated 500 offenders for treatment per year, education classes for family members (serving approximately 700 family members per year); training for correctional staff; parole board reports; sex offense specific evaluations; law enforcement registration coordination; research; the cost of

*The SOTMP program costs cover: group therapy (760 inmates per year), supplemental individual therapy, polygraph testing (135 exams per year); identification of sex offenders at the Denver Reception and Diagnostic Center (DRDC) (1,170 offenders per year); administrative review preparation and participation per the Chambers decision screening an estimated 500 offenders for treatment per year, education classes for family members (serving approximately 700 family members per year); training for correctional staff; parole board reports; sex offense specific evaluations; law enforcement registration coordination; research; the cost of obtaining offense records; and, recording offense information in Violent Criminal Apprehension Program (VICAP) for use in offenders' evaluations, registration, and program evaluation.*

<sup>72</sup> Cost information obtained from SOTMP administrators in a document titled “Inmate Sex Offender Treatment Costs” (no date provided).

<sup>73</sup> This figure includes \$144,100 used for polygraphs and community treatment of parolees.

<sup>74</sup> CDOC figure from “Overview of the FY 2003-04 General Fund Budget Request,” available at [http://www.state.co.us/gov\\_dir/govnr\\_dir/ospb/governorsbudget/fy2003-04/govbudgethighlights03-04.pdf](http://www.state.co.us/gov_dir/govnr_dir/ospb/governorsbudget/fy2003-04/govbudgethighlights03-04.pdf) (p. 11).

<sup>75</sup> See outcome results on pages 108 to 127 of this report.

<sup>76</sup> The total adult inmate jurisdictional population was 16,359 as of December 31, 2000 (CDOC, Monthly Project Status Report, May 12, 2003).  $4,000/16,359=24$  percent.

<sup>77</sup> Chambers sued the Colorado DOC three times over being recommended for sex offender treatment even though he had never been convicted on a sex offense charge. Each time, DOC’s position was upheld. However, upon appeal, the 10th Circuit Court eventually ruled in his favor saying that the sex offender label was so stigmatizing as a result of registration that DOC would have to conduct a due process procedure before labeling him a sex offender for treatment purposes (US Court of Appeals, 10<sup>th</sup> Circuit, No. 97-1023). This required every offender recommended for sex offender treatment to receive a due process hearing. SOTMP staff temporarily suspended treatment services while they assessed with the review hearings.

obtaining offense records; and, recording offense information in Violent Criminal Apprehension Program (VICAP) for use in offenders' evaluations, registration, and program evaluation.

If the cost is distributed evenly across *only* those inmates participating in SOTMP treatment groups (approximately 760 per year), this amounts to an average of \$3,438 per offender for a year of treatment and law enforcement registration services. However, program resources are devoted to many other activities besides treatment for a specified number of offenders, and since some of those activities are the responsibility of DOC as mandated in statute, treatment resources enable DOC to stay in compliance with legislated requirements.

***FINDING: Administrators reported concerns regarding the costs of the TC.***

Despite the relatively small percent of the Department of Corrections budget consumed by the SOTMP program, and the extent to which the treatment funds are also used for risk management, it was clear that administrators had concerns regarding the efficacy of the program. Administrators' comments during interviews included concerns that TC beds were not filled,<sup>78</sup> that they were unsure of the program results and how sex offender treatment worked, and whether the costs of the program justified the expense. One administrator stated that when budgets are cut, continuation of the program is at risk. Some commented that money was a barrier to the operation of the TC, and that the "downside of the TC" was the higher costs associated with training and hiring certified therapists as required by the Sex Offender Management Board. However many mental health therapists at DOC are psychologists with doctorate degrees whose pay scale is higher than the primarily masters-level SOTMP therapists.

**(3) Clear Policies**

The agency should maintain written administrative policies and procedures that are known to staff (Therapeutic Communities of America, 1999: Standard AD1).

***FINDING: SOTMP policies are well documented and available to TC staff. Offender admission, suspension and termination policies are outlined in the treatment contract, along with rules for participation and moving through the program. A sanction grid has been developed that standardizes consequences for undesirable behaviors.***

The TC has written admission, suspension, and termination policies for inmates. Situations that may result in termination or suspension from the program are outlined in the Treatment Contract that offenders must sign when starting the TC program.<sup>79</sup> Serious violations result in termination and include the following: sexual aggression or harassment, violence or threats of violence, patterns of manipulation, exploitation of others, contacting the victim, compromising safety rules, non-participation in treatment or interruption of the group process. During our review of 578 files of TC participants we found numerous reasons for termination. Although extensive detail was not available,

---

<sup>78</sup> Since our evaluation, all TC sex offender beds have been occupied. Just prior to our initiating the evaluation, hiring freezes caused the program to be short-staffed, and services were reduced accordingly, so treatment beds were not filled.

<sup>79</sup> Appendix I contains a copy of the treatment contract.

the majority of reasons for termination were those behaviors described in the treatment contract.<sup>80</sup> Qualifications and expectations for moving through various phases of the program are outlined in the program manual, and offenders are aware of these requirements because the rules for program participation are established through the treatment contracts and reinforced in group sessions and other interpersonal interactions. The “sanction grid”<sup>81</sup> provides clear guidance to implement consistent consequences for polygraph examination results.

During our review of 578 files of TC participants we found numerous reasons for termination. The majority of reasons for termination were those behaviors described in the treatment contract.

#### (4) Clear Positions on Confidentiality

The clinical environment for sex offenders is different from traditional therapy settings and therapeutic milieus. It is marked by more external controls and less trust between the therapist and the client; there is an emphasis on goal and limit setting; and, the sex offender treatment setting includes a qualified position of confidentiality (Salter, 1988:34-95). Offenders are best served in treatment that holds them accountable for their harmful sexual and assaultive behavior (Mussack and Carrick, 2001). Allowing offenders confidentiality about their sexual assaults, deviant behavior, or current risks prevents offender accountability (Loss, 2001). In general, clinicians operate on the assumption that information that is shared by the offender should be provided to anyone who needs to know (Lowe, 2001).<sup>82</sup>

The clinical environment for sex offenders is different from traditional therapy settings and therapeutic milieus. Offenders are best served in treatment that holds them accountable for their harmful sexual and assaultive behavior.

***FINDING: The TC operates on a policy of “no secrets.” This position is made clear to offenders through the treatment contract. This is considered best practice in the treatment of sex offenders.***

The state Sex Offender Management Board *Standards and Guidelines* (1999) require that the treatment contract describe the limits of confidentiality to those participating in sex offender treatment. Guidelines regarding confidentiality are stated in the TC Treatment Contract. The contract specifies that inmate issues will be brought to the attention of the community, and that these may include behaviors, information from correctional records and homework assignments, and that “all resident information is Therapeutic Community information.”<sup>83</sup>

Inmates must sign a release of confidentiality (of all current and prior treatment records) to participate in treatment. However, any discussion of the identity of others in the program or their personal issues outside the treatment environment is a direct violation of the treatment contract. Therapist responsibilities regarding confidentiality are also specified in the contract: therapists may provide polygraph examination findings, and

<sup>80</sup> Appendix L contains a list of reasons for termination extracted from files.

<sup>81</sup> Appendix M contains a copy of the sanction grid.

<sup>82</sup> It should be noted that this policy is different from the TCA stance regarding confidentiality, and this reflects the difference in treatment approaches for sex offenders compared to drug and alcohol offenders. For the latter group, TCA recommends that confidentiality is “strictly maintained.”

<sup>83</sup> Treatment Contract, p.8. SOTMP training materials state: “Recovery involves every part of life—every aspect of the inmate’s life and behavior is subject to scrutiny in the TC.”

any other information about the offender to anyone in the correctional/support system without the written consent of the offender.<sup>84</sup> This includes case managers, parole officers, the parole board members, community correction center staff, and other professionals who may be “responsible for the offender’s mental health treatment.” Further, the contract states that any information regarding injury to self or others will not be kept confidential and that therapists are legally required to report “any specific” information regarding child abuse to the state department of social services.<sup>85</sup>

Since the goal of the SOTMP program is “no more victims,” inmates are informed in the treatment contract that information regarding criminal patterns of behavior may be released to law enforcement.

### (5) Treatment Plans

According to TCA *Standards*, each offender in the TC should have a “written treatment plan that is reviewed and updated periodically” (Therapeutic Communities of America, 1999: Standard AD5).

***FINDING. The use of individualized treatment plans as working documents that guide the interventions and measure progress toward goals appears to be underutilized by TC staff.***

The program manual documents the necessity for developing individual treatment plans. Therapists are expected to prepare individual treatment plans shortly after the offender’s assessment, and updates are due 60 to 90 days thereafter.

We found that 38.9 percent of 578 inmate files we reviewed contained treatment plans, but many of those (48.0%) consisted of a standardized form. The form generally listed mental health, drug/alcohol use, stability of functioning, developmental issues, medical issues, evaluation of self, denial, violence and coercion, communication and relationship skills, recreation and leisure time needs, and trauma history. These plans, however, were not individualized.<sup>86</sup> Further, we found little evidence that this material was used as a working document. That is, we found few regular updates and even fewer meaningful measures of treatment progress. For example, if a treatment goal was controlling anger, an inmate’s progress toward this goal was measured by attending anger management classes (which everyone must attend) rather than specifying behavioral changes related to anger. Some staff validated our interpretation regarding the lack of individualized plans. One interviewee noted that while they complete individual treatment plans, “they aren’t worth anything... A plan should evolve over time but [these plans] are pretty stagnant.” Others noted that all offenders are treated similarly, as one therapist stated, “we still work under the model of one size fits all.”

Many staff reported, however, that *individualized treatment* occurs in a variety of ways. For example, the integration of a variety of therapy groups helped developmentally disabled inmates transition from Phase I into the TC. A psychiatrist manages medication

---

<sup>84</sup> Our study was conducted prior the time period when new HIPAA regulations were to be in place, and we did not examine how any new regulations might impact this consent policy.

<sup>85</sup> Treatment Contract, p.8.

<sup>86</sup> We considered a plan to be “individualized” if it contained specific notes (other than the typed form) that addressed issues unique to the individual.

needs, a therapist addresses drug and alcohol issues, and issues that surfaced in the polygraph were explored through papers and homework assignments specific to the inmates' needs. Individualized treatment was the responsibility of the primary therapist who prioritized important issues. However, sex offender issues were always the first priority.

#### (6) Quality Assurance

TCA Standard AD2 states that programs should have a written quality assurance plan in place to ensure that corrective action takes place in a timely manner.

***FINDING: There is no formalized, long-term procedure to observe groups, review files or perform any other audit process.***

When asked about quality assurance procedures, many TC staff stated that there was no consistent auditing or formal supervision process, and no process for quality assurance. While the team feels they are good at self-monitoring, this does not, by itself, equate to quality assurance. Most staff we spoke with thought there was not much in place to assess clinical skills.<sup>87</sup> When the TC received feedback on this issue they indicated that they intended to begin forms of quality control including sitting in on groups and videotaping groups to provide feedback on group dynamics. Efforts to create a quality control staff position and to obtain the necessary resources to implement a system to monitor program integrity has been resisted by DOC administrators, according to interview data.

### **Component 4. Staffing**

Good treatment staff, clinical supervision, and trained correctional staff are crucial elements for sex offender therapeutic communities (De Leon, 1995). The TCA advises: "It is essential that the entire staff function in a manner that is consistent with the philosophy and practice of the TC and that security and TC staff needs to be sensitive to each others' needs and approaches" (Therapeutic Communities of America, 1999: 7). The Colorado *Standards and Guidelines* developed by the Sex Offender Management Board (SOMB) require specific qualifications for treatment providers and evaluators.<sup>88</sup> These include professional licensing (if the provider is at the full operating level), educational requirements, clinical experience, supervision, and training requirements.

#### (1) Staff Selection and Qualifications

Staff selection procedures should attend to the attitudes, knowledge, motivation, and experience of staff to ensure that they are compatible with the demands of the program. According to the Association for the Treatment of Sexual Abusers' Standards and Guidelines, members should have education, training, and experience in the evaluation, treatment, and management of sexual abusers. This includes having a graduate degree in a related field, specific training and experience in working with sexual abusers, and

---

<sup>87</sup> Although some staff did comment that it is anticipated that the Program Manager will observe groups, check files, meet with staff and monitor treatment plans.

<sup>88</sup> See Section 4.000, "Qualifications of Treatment Providers/Evaluators in the Standards and Guidelines for the Assessment, Evaluation, Treatment and Behavioral Monitoring of Adult Sex Offenders," Colorado Sex Offender Management Board, June 1999.

shall be under the direct supervision of a qualified mental health provider (ATSA, 1.01). Selecting and training competent staff to work with and understand sex offenders is important (Lowe, 2001). Lowe lists characteristics to consider when interviewing potential staff members, including: appreciation for the dignity and worth of the offender, a high level of self-confidence, a history of using healthy coping strategies, and the ability to use creative problem-solving techniques.<sup>89</sup>

***FINDING: SOTMP managers engage in a careful selection and hiring process, and TC staff are qualified and committed.***

Staff is not hired directly into the TC, but into the SOTMP program.<sup>90</sup> Lack of experience working with sex offenders is not considered a disadvantage; rather, it allows for the program managers to train new therapists in the philosophical foundations of treatment delivery in the SOTMP. Further, it is difficult to find therapists with prior experience working with this specialized population. Managers considered it an advantage, however, for employees to have experience working in human services with children, adolescents, victims, and families.<sup>91</sup> Personal qualities such as stability, common sense, a willingness to accept feedback, honesty, integrity and dependability were mentioned as highly valued; these are examined through an extensive interview process that includes approximately 30 questions. Other qualities include the ability of the individual to work in a team setting, a lack of active personal victimization issues, and an appropriate level of assertiveness. Individuals passing the interview are invited to spend a day with the program so the applicants can determine if the job is a good fit for them.

Currently staff may be hired with only a Bachelors degree if they are working on their Masters degree. Prior policies were to hire only those with a Masters Degree, but changes in job classification have directed the new policy.

***FINDING: Hiring freezes, lengthy state hiring processes, and an inability to meet salary requirements, combined with the type of work (treating sex offenders in prison) make it difficult to hire qualified staff.***

*Department hiring freezes, lengthy state hiring processes, and state salary range restrictions, result in "losing" candidates before they can be hired.*

According to interviews with TC administrative staff, some of the difficulties in keeping the program operating at maximum capacity (96 beds) are rooted in an inability to hire staff to provide treatment. Department hiring freezes, lengthy state hiring processes, and state salary range restrictions, result in "losing" candidates before they can be hired. Managers reported that staff sometimes quit shortly after they are hired, perhaps because of the difficulties working with the sex offender population. When this occurs, the hiring process must be initiated again. Managers report difficulty recruiting qualified staff due to the educational requirements and the difficulty of the work. However, we found that those

<sup>89</sup> As noted several times in this report, TCA recommendations for staffing state that the majority of staff should be TC graduates. For reasons already described, this is not advisable in the treatment of sex offenders.

<sup>90</sup> All information is from interviews with program administrators.

<sup>91</sup> According to English, Pullen and Jones (1996), interviews with therapists found they believed they were better therapists with sex offenders when they previously (or simultaneously) worked with victims of sexual assault.



who stay with the program do so for an average of 5 to 7 years offering a stable core of qualified and committed therapists.

***FINDING: The TC has experienced, well-qualified therapists who have worked with sex offenders and other populations prior to working at the TC.***

Nine out of 10 TC staff who completed the questionnaire indicated they worked in Phase I of the SOTMP program at the Fremont Correctional Facility prior to coming to the TC. After working in Phase I some therapists then moved to the TC to work in Phase II of the program. All therapists who had worked at Fremont reported receiving training on sex offenders at that facility. On average, current therapist worked with sex offenders for three and half years prior to coming to the TC.<sup>92</sup> Most TC therapists reported experience with other populations as well.<sup>93</sup>

*On average, current therapists worked with sex offenders for three and half years prior to coming to the TC. Most TC therapists reported experience with other populations as well.*

(2) Training

“Training is the lifeblood of a treatment program, and program success is based a great deal on it” (Lowe, 2001:41). Program staff should receive joint training in order to build the cohesion of the team and to ensure that individual members are knowledgeable about the goals and methods of the treatment program. The TCA *Standards* require a TC staff orientation consisting of at least 30 hours of didactic and experiential training, as well as ongoing training (Therapeutic Communities of America, 1999: Standard S4). Further, administration officials should receive a minimum of 15 hours of TC-specific training (Therapeutic Communities of America, 1999: Standard S5). Sex offender treatment is evolving<sup>94</sup> from research that investigates and evaluates treatment approaches. This requires treatment providers to receive ongoing training on a myriad of topics.

*“Training is the lifeblood of a treatment program, and program success is based a great deal on it” (Lowe, 2001:41).*

Beaton and Murphy (1995) studied “secondary PTSD” among those who help the traumatized: police, fire fighters, emergency medical professionals, and other emergency workers. They found that these individuals were most vulnerable to “compassion fatigue” when they were faced with the pain of children. VanderKolk, McFarlane and Weisaeth (1996) reviewed the literature on helper’s secondary trauma resulting from war and natural disasters and found that training is essential to decrease surprise, prepare for the unexpected, maximize

*Training is essential to decrease surprise, prepare for the unexpected, maximize a sense of mastery and optimal performance, and decrease the sense of defeat.*

<sup>92</sup> Based on responses from 10 out of 11 current staff to our therapist questionnaire. Average time spent working at Fremont was a little over two years (25.7 months).

<sup>93</sup> Working with either juvenile, adult or both types of offenders; developmentally disabled, domestic violence populations; and working in private practice or in psychiatric hospitals.

<sup>94</sup> For example, it has long been understood that many sex offenders suffer from empathy deficits, allowing them to objectify and harm their victims. Empathy training has become a core component of the treatment of sexual offenders. However, recent research suggests that rapists may suppress empathy toward their victim, so “[i]t is suggested that empathy deficits in rapists might better be construed as cognitive distortions specific to their victims and should be addressed in that manner in treatment” (Fernandez and Marshall, 2003:11). This study illustrates the need for frequent training and discussions of relevant research findings, along with the development of new approaches when these seem appropriate for the specific population receiving treatment.

a sense of mastery and optimal performance, and decrease the sense of defeat.

*The constant exposure to violence and manipulation, watching many offenders fail treatment efforts and the true risk presented by the population combine to make this job uniquely taxing. Frequent training keeps therapists at the "top of their game." It is essential in the fight against burnout and secondary trauma.*

Therapists working with sex offenders are required to understand the trauma experienced by the victim and the insidious manipulation used by the offender to abuse his victims (Pullen and Pullen, 1996). Therapists are exposed to this trauma and manipulation from multiple sources: the case file, documented sexual histories, disclosures of additional victims and assaults during group therapy, and information disclosed in polygraph examinations. Also, therapists become the object of manipulation by offenders whose central features of interaction often involve power and control. The constant exposure to violence and manipulation, watching many offenders fail treatment efforts and the true risk presented by the population combine to make this job uniquely taxing. Frequent training keeps therapists at the "top of their game." It is essential in the fight against burnout and secondary trauma.<sup>95</sup>

According to the SOMB *Standards and Guidelines* (1999:43-44), training should include 80 hours every few years on topics specifically related to evaluation and treatment methods for sex offenders and include training in the area of victimology. The training may include but is not limited to:

- statistics on offense/victimization rates,
- typologies, sex offender assessment,
- sex offender evaluation,
- sex offender treatment techniques (evaluating and reducing denial, cognitive/behavioral techniques,
- relapse prevention, empathy training),
- offender/offense characteristics,
- sex offender risk,
- physiological techniques (polygraph, plethysmograph, Abel Screen),
- victim issues,
- family reunification/visitation,
- legal issues,
- special sex offender populations (sadists, developmentally disabled, compulsive, juvenile, female),
- pharmacotherapy with sex offenders,
- impact of sex offense,
- assessing treatment progress,
- secondary and vicarious trauma,
- anger management,
- sex education,

---

<sup>95</sup> Secondary trauma is trauma experienced not directly but "secondarily" through empathizing with victims or constant exposure to traumatic material. It is an expected condition for therapists, probation and parole officers, and polygraph examiners to experience at various times in their careers. It results from prolonged exposure to violent material, particularly from the descriptions of heinous acts committed against victims of assault (Pullen and Pullen, 1996).

- supervision techniques,
- philosophy and principles of the SOMB, and
- group therapy dynamics.

***FINDING: TC staff receive the following training: an initial 40 hour training provided by the SOTMP administrators and staff; academic training; conferences, seminars and other training; and, on-the-job training and supervision while working at Phase I and, later, at the TC. Monthly SOTMP staff meetings often include training.***

All correctional staff, including therapists hired for the SOTMP, attend DOC's training academy. The training academy has several mandatory classes that everyone working within the prison must take including firearms qualifications, emergency plan training, fire safety, hazardous materials, preventing disease transmission, first aid and use of force, CPR, and pressure point control tactics. Additionally, SOTMP staff attend training specific to working with a sex offender population. The TC manual underscores the importance of training by describing a list of therapist responsibilities that includes mandatory SOTMP training.

After hiring, SOTMP staff members receive 40 hours of "orientation" training that covers current treatment interventions, patterns of criminal thinking, transition to the community, parole board summaries, RAM supervision, family support education program, sex offender manipulation tactics, and job impact of working with sex offenders. However, this training occurs after there is an adequate number of therapists that need to be trained so there may be a time lapse between when a new person is hired and when they actually receive training.

In the past, SOTMP had funding for therapists to attend one training each year. However, the current state budget crisis resulted in the elimination of this activity. Now, if a therapist chooses to pay for additional training, they generally are allowed time to attend.<sup>96</sup> Training opportunities are provided on various topics at monthly SOTMP meetings. During our evaluation we observed trainings at these meetings that addressed information on VICAP, failure to register, and secondary trauma.

***FINDING: Orientation training does not always occur in a timely fashion and staff, through interviews, suggested that additional training that focuses on building therapists' skills in facilitating groups would be useful. Staff also suggested other topics for training.***

As was reported earlier, most staff from the TC works in Phase I prior to moving to the TC. Therapists are primarily oriented from Phase I to the TC by using an internal mentoring process.<sup>97</sup> They are paired up with an experienced therapist, observe the group process and serve as a third therapist, and attend daily staff meetings where questions can be answered.

Despite this preparation, several staff described orientation to the TC in terms of a "hit the ground running" approach. The lack of hands-on preparation for conducting groups was mentioned in some staff interviews. This discomfort with the lack of preparation for

---

<sup>96</sup> According to interviews with program administrative staff.

<sup>97</sup> They also review an orientation checklist, included in Appendix N.

handling groups, despite experience in Phase I and academic preparation, may stem from the fact that most of the groups in Phase I are delivered in a psycho-educational rather than process format. Further, Phase II groups deal with subject matter, such as personal cycles of offending, that are more complex than material discussed in Phase I. These issues, coupled with the difficulties of dealing with the sex offender population where manipulation, power and control and other issues are used as communication tactics, along with the violent subject matter, likely contribute to the discomfort some therapists may feel when facilitating Phase II groups, despite their prior training and experience.

To obtain more information about training, this topic was included in the questionnaire given to therapists (discussed earlier). Half of the ten therapists responding said they received some training on sex offenders during their academic experiences. Additionally, half reported attending workshops, conferences or seminars on sex offenders prior to working with them, and all reported attending these sorts of trainings since working with this population. Most (9 out of 10) therapists said training was both timely and adequate for their job performance.

However, as noted above, therapists suggested during staff interviews that not enough time is spent ensuring that therapists are well trained and skilled at group therapy facilitation. Not surprisingly, then, in questionnaire responses, several therapists reported that information and training on group dynamics, offender characteristics and communication as it relates to the group work would be helpful. While no single training topic was mentioned by a majority of therapists, requests for additional training included:

- information about co-therapist issues,
- trouble shooting difficult cases,
- new research on sex offenders,
- treatment outcomes,
- other sex offender treatment communities, and
- updated information on covert sensitization.

***FINDING: Training that focuses on community living may be needed.***

We determined that additional training is necessary that specifically focuses on therapeutic living, the integration of work assignments with the TC, and the use of the community to solve problems. Phase II requires that staff have expertise in sex offender treatment *and* therapeutic communities, and each is its own area of specialization. While some members of the treatment team consistently use the community as an intervention, an intensive training that includes therapists, correctional officers and work employees would enhance the potency of the TC.

***FINDING: The need for ongoing training for SOTMP staff is not well understood by DOC administrators.***

Interview data revealed that some administrators were uncomfortable with the amount of training already received by therapists in the SOTMP. Prior research (English, Pullen and Jones, 1996) found that it is not uncommon for agency administrators to question the amount of training required by staff working with sex offenders, nor is it uncommon for non-sex offender staff to complain about the amount of specialized training their colleagues receive. This prior study found that agencies can overcome the tension resulting from the appearance of “over-training” by engaging in two activities:

1. agency officials attended trainings so they became aware of the scope of complicated issues and extent of violent material that is involved in the treatment of sex offenders, giving them the understanding they need to explain the training requirements to those above them in the chain of command, and
2. open the workshop to colleagues who disapprove of the staff time spent training. Those who accept the invitation will hopefully have the experience of the agency officials, and those who decline will likely express their disapproval, not of the training, but of the dangerous population the training serves (English, Pullen and Jones, 1996).

**(3) Supervision**

TCA Standard S8 states that all clinical staff should receive at least two hours of individual and 6 hours of group clinical supervision per month.

***FINDING: Some therapists noted that they received supervision on a regular basis while others would like scheduled or increased supervision.***

Through interviews we learned that typically the therapists who were not yet licensed received individual clinical supervision on a regular basis, while licensed therapists did not. However, staff indicated that supervision was ongoing, and that staff meetings often provided guidance and support to therapists. Therapists also stated that their supervisor is generally accessible, if needed. Nevertheless, answers from the therapist questionnaire indicated that while some therapists noted that they received regular supervision, others would like regular or more supervisory support.<sup>98</sup> This is a resource issue since supervisors not only oversee program activities but act as liaisons with facility and institutional mental health staff.

**(4) Training and Integration of Non-Therapeutic Staff**

De Leon (2000, p. 385) describes general guidelines for adapting a TC to special settings, including prisons. He states that, “effective adaptation of the TC model and method requires that all staff, regardless of professional training or treatment orientation, is committed to the implementation of the TC approach model and method.” TCA standards underscore the importance of TC and security staff understanding the needs

---

<sup>98</sup> Results of Therapist Questionnaire (3 out of 10 responses).

and approaches that each uses. TCA Standard S7 specifically suggests that, to facilitate this, TC and security staff should be cross-trained.

***FINDING: Despite the importance of the role of correctional officers in facilitating the 24/7 treatment milieu, correctional staff is provided limited training and orientation to the TC program.***

According to the program summary,<sup>99</sup> correctional staff working in the TC facility must participate in TC training. Correctional officers who work in the living unit are expected to provide feedback on inmate behavior to treatment staff. Housing staff, work supervisors, case managers and therapists should meet weekly to staff inmates in the program. The therapeutic community program manual directs SOTMP therapists to meet weekly with drug and alcohol therapists, case managers, kitchen and greenhouse staff to discuss issues affecting the program. Additionally, according to the summary of the program,<sup>100</sup> SOTMP therapists should help facilitate cooperation between correctional and TC staff by offering training to the correctional staff regarding working with sex offenders.

While correctional staff and case managers attend DOC's training that includes information on games criminals play and dynamics of sex offenders, they do not participate in training specifically designed for those working with sex offenders in a treatment environment nor do they receive training specific to therapeutic communities and the community as method model. Since therapists are available only during business hours, correctional officers with the proper training can play an important role in the "24/7" TC milieu.

***FINDING: Staff perceives that individual officers vary in their level of "buy in" to the program. The inconsistency in "buy in" from correctional staff may negatively impact the program by creating barriers or missed opportunities to provide treatment.***

According to interview data, staff perceives that some officers "buy in" and some do not. Therapists said that some officers think highly of the TC, while others think that sex offenders cannot be helped.

*We observed several examples of non-TC staff participating in the 24/7 milieu. For example, a non-TC staff member came to a morning TC staff meeting and reported on issues involving an inmate. In another instance, non-TC staff was requested by therapists to monitor the activities of a particular offender.*

The TC staff had varied opinions on the extent of integration of correctional staff into the TC milieu. Some said officers participate in the milieu by logging issues and concerns. Other TC staff discussed the lack of support of the program by kitchen and housing staff, and that most correctional staff was of the opinion that mental health workers were "worthless." We observed several examples of non-TC staff participating in the 24/7 milieu. For example, a non-TC staff member came to a morning TC staff meeting and reported on issues involving an inmate. In another instance, non-TC staff was requested by therapists to monitor the activities of a particular offender. (We assumed that since the therapist requested this participation, there was a working relationship between the officer and the therapist.) However, during group observations, inmates reported that they were sometimes told by non-TC staff to leave their "TC crap" at the door or to "save it for group."

<sup>99</sup> Colorado Department of Corrections Program Summary (From the 50-state survey, 2000, p. 44).

<sup>100</sup> Colorado Department of Corrections Program Summary (From the 50-state survey, 2000, p. 31).

Inmates said these comments sometimes made it less likely that they would confront another offender's behaviors at work. In Crossover groups (groups that discuss sex offender and drug and alcohol member issues), we heard many descriptions of activities that reflected a work environment that included the use of profanity, stealing, and fighting. This environment would not be conducive to delivery of treatment.

This inconsistency in the amount of "buy in" from non-TC staff can have negative effects on the quality of the program, by making it less likely that non-TC staff will participate in the 24/7 milieu. The participation of these staff is critical since TC staff is not available 24 hours per day.

## **Component 5. Facility/Environment**

According to De Leon (2000), the TC environment contrasts with the traditional prison environment. The TC atmosphere is one of safety, responsibility and caring, promoting participants' identification with the treatment program rather than the prison culture and the inmate code. The facility and the environment play an important role in enabling offenders to learn healthy ways of interacting and solving problems. The environment also enables offenders to take responsibility for the TC space, maintaining it with a sense of ownership and pride.

### (1) Housing/Location

Recognizing the importance of the physical space when treatment is delivered by means of a therapeutic community, TCA Standard FE1 states the following: "To the extent possible the program should be a self-contained environment within the larger prison setting." To this end, the standard requires minimal mixing of the offenders participating in the TC and the general population.

***FINDING: The Arrowhead TC staff agreed that housing the general population within the TC created numerous problems. Staff noted that the general population (GP) have a negative influence on the unit, and that they may "contaminate" the TC approach.***

While the TC housed sex offenders, it also housed general population (GP) inmates and drug/alcohol offenders participating in the substance abuse TC program.<sup>101</sup> Staff agreed that housing the GP at the TC created numerous problems, "contaminating" the TC approach. Examples of program contamination resulting from the integration of the two populations are presented below:

- Maintaining a therapeutic environment was difficult when rules applied to TC members that did not apply to the GP. For instance, TC members were prohibited from using profanity and pornography yet these were in common use among the GP,
- Confidentiality issues occurred when treatment groups were held in common living areas where disclosures could be overheard,

---

<sup>101</sup> During late 2001 and 2002, when DCJ researchers were on-site conducting the evaluation, the TC was not filled with sex offenders. The program was unable to operate at full capacity because a hiring freeze interfered with managers' abilities to fill vacant therapist positions.

- Members of the GP sometimes openly expressed negative views of sex offenders,
- Sometimes TC members shared a room with a member of the GP, significantly interfering with the therapeutic milieu, and
- The GP operates, in general, according to the convict code and so is less likely to support (and, in fact, is contrary to) the positive and pro-social ways of thinking encouraged by the TC.

Not only were approximately 50 general population (GP) inmates living in the 96-bed sex offender TC at the time of the evaluation, but the Arrowhead Correctional Center also is home to the alcohol and drug TC. Many of the problems associated with housing the GP in the TC, discussed above, also pertained to mixing the drug and alcohol (D & A) treatment population with the sex offenders in the TC. However, integrating these populations also had some advantages (discussed further in the next finding).

***FINDING: Mixing the drug and alcohol population with sex offenders seems to have both positive and negative effects on the treatment environment.***

TC staff working with sex offenders discussed, during interviews, the consequences of sex offenders and drug and alcohol offenders living together. On the positive side, staff mentioned the abilities of drug and alcohol inmates to help build a sense of community, provide good feedback, and give sex offenders opportunities to communicate and interact with openness and honesty with a non-sex offending population.

Conversely, some staff also voiced concerns that drug and alcohol program members may “pollute” the sex offender treatment culture. For example, these offenders can encourage negative behaviors, such as providing pornography to sex offenders. Likewise, some staff believed that a number of drug and alcohol community members were less interested in treatment and more interested in supporting criminal behaviors. Unfortunately, the presence of even a few pro-criminal attitudes can powerfully affect the treatment environment. However, some of the therapists believed access to these opportunities for inappropriate behavior were also opportunities for offenders to behave responsibly by refusing to participate in activities that have no therapeutic benefit.

To ensure issues were addressed between participants in the two types of treatment programs, clinical staff facilitated weekly “crossover” groups consisting of inmates from both TCs. During these groups, we heard discussions of conflicts between sex offenders and drug and alcohol community members. Sometimes these conflicts stemmed from a sense of superiority on the part of drug and alcohol offenders, regardless of their conviction crime, as one drug and alcohol member noted, “at least I’m not a sex offender.” Other conflicts appeared to be related to general hostilities that surfaced between individuals. The groups openly discussed these issues, and inmates participated in offering their perceptions and suggestions.

Also, as discussed earlier in this report, drug and alcohol and sex offender therapeutic styles were different, and this may be confusing for offenders attending these groups.



## (2) Facility Space

TCA Standard FE3 states that the facility should be clean, safe and adequate in terms of space to meet the needs of the TC program.

***FINDING: Group meeting space is sometimes inadequate and seems to negatively impact the program.***

Staff reported through a self-administrated questionnaire and interviews that groups are sometimes cancelled because of a lack of space. In the questionnaire, therapists ranked lack of space as the third most likely reason that therapy groups were cancelled, after trainings and emergency drills. In some instances, the space that was available was not conducive to proper group facilitation. Activities interfered with the proper delivery of services because conversations could be overheard, and sometimes it was difficult to hear whoever was speaking in the group.

At the greenhouse, distractions were quite common. These included loud music, vacuuming, and people coming in to get chairs. Also, some areas had cold or hot room temperatures and, depending on the space, other offenders frequently walked through the area. Two group rooms at the greenhouse were separated only by a thin, folding door, providing inadequate privacy. The impact of these distractions on the group varied. In some groups, the material, presentation, and participation were so intense that these interruptions had little impact. In other groups, the noise and outside activity level resulted in an inability to hear therapists and participants.

The Living Unit's Day Room and visiting rooms were particularly troublesome since other offenders regularly moved through these spaces to travel to other areas of the unit, use vending machines, and so on. These areas seemed more like corridors than group rooms. Noise levels here were extremely high. The lack of privacy and the unstructured setting for groups in these areas seemed to de-emphasize the importance of the group. Further, general population inmates (that is, non-sex offenders) in the living unit often walked across group space and inhibited open communication among the participants. In one instance, a therapist suggested that the group member not discuss an aspect of his sexual assault cycle because non-group inmates were within listening range.

Sometimes therapists tried to eliminate distractions, for example, by opening or closing windows. Other times there was simply not much that could be done. The least distracting settings for the groups were the TC Administration and Programs buildings. In these buildings, more space was available, and rooms were more private, making these locations most appropriate for therapy groups. Since the program building was "inside the gate" the need to count offenders going through the gate was eliminated, speeding up the process of moving from group to group.

## (3) Safety

The program must provide a safe and secure environment to encourage an offender to be honest and take the risks needed for change. De Leon describes physical and psychological safety as essential experiences in the TC process. He states that "maintaining the safety of the social environment is essential for sustaining psychological safety in the change process" (2000, p. 322). Lowe (2001: p. 41) states, "It will not matter what the treatment model is or that it has tools the client population can use... if

the general atmosphere of the program does not provide safety and security for the clients.”

***FINDING: For some inmates, sharing an environment with the general population may inhibit their willingness to be open and honest in certain situations because they are fearful of being labeled a “snitch.” Other inmates do not seem to share this concern.***

An important consequence of sex offenders sharing space with inmates from the general population and the D & A TC is that the presence of these inmates may quell the willingness of sex offenders to make honest disclosures about themselves and others. From our observations, news travels quickly through the community.<sup>102</sup> Likewise, information travels from facility to facility. During group observations, we learned that many offenders knew each other prior to coming to the TC, having spent time together in other DOC facilities. These realities create a climate where reputations, for better or worse, are an important topic of discussion.

Sex offenders in the TC are expected to behave in ways that run contrary to the "inmate code of conduct." For example, they are expected to disclose information about their "brothers" in the form of pull-ups, a therapeutic tool that encourages awareness of responsible behavior. In the general population, an offender who provides information about other offenders is referred to as a "snitch" or a "rat." Neither of these labels serves an inmate well. As one inmate pointed out during a focus group, "...if you fail the TC and then go to Centennial you are going to get killed because you are considered a rat and a punk. The inmates know that and have to be willing to risk that as part of their lives." Others in the group were nodding their heads in agreement while the inmate expressed his concern. This view was also expressed by an inmate who, during a conversation after group, commented that, "they [the TC] don't realize that this is a life and death situation." This remark came after a discussion regarding the lack of openness among offenders in a Crossover group (with sex offender and drug and alcohol participants).

*I'd heard all the stuff that goes around.*

*It's "oh yeah you guys are going to go over there and snitch on each other. Getting over here and seeing how it worked I came to believe it was a stroke of genius."*

*One inmate said, "You got to break the convict code to get out of that. People think it is still snitching and it's really to be helping. People who I think are struggling with it are usually newer members of the community."*

However, other inmates in our focus groups did not seem to think that this fear was valid. One inmate stated, "I went from having a sick feeling in the pit of my stomach before I came over here thinking about the pull-up system because of all the stuff I'd heard all the stuff that goes around GP about it being snitch pads. It's 'oh yeah you guys are going to go over there and snitch on each other, they're all snitching and they're a bunch of snitches. They got write-ups on each other. They rat each other out. It's a rat program and this that and the other.' Getting over here and seeing how it worked I came to believe it was a stroke of genius." Another inmate stated that the TC is "an open community. It's not secretive like it has to be in other places for your own health and literally your life. It's a community where we are comfortable with each other because we know each other." As stated elsewhere in this report, there was also a general consensus that the pull-up and RFG system are "essential" to the program and making it work. Inmates feel that it is a good way to learn to confront each

<sup>102</sup> For instance, within hours of our arrival to observe groups, the community was filled with rumors that we were state auditors observing the community to recommend closure.

other and look at their own issues. As one inmate said, "You got to break the convict code to get out of that. People think it is still snitching and it's really to be helping. People who I think are struggling with it are usually newer members of the community." Another inmate stated that he has been to the TC twice and back. He stated he has, "never had a problem. Never had anybody jump me."

## **Component 6. TC Program Elements**

TC program elements are designed to help the offenders build, and feel a part of, their community. This includes work, wing and house meetings, rituals and rites of passage, activities and group therapy. According to the TCA, "every element and activity in the TC has multiple purposes, including: community building, education, increasing self-awareness and self-esteem, developing employment and independent living skills and improving interpersonal skills" (Therapeutic Communities of America, 1999: 8).

### (1) Wing Meetings and House Meetings

According to the TCA standards, daily meetings are organized to serve several purposes. Meetings can motivate and energize program participants, as well as transact community business (Therapeutic Communities of America, 1999, Standards TC9 and TC10).

***FINDING: Daily meetings occur where inmates can share news and events; one of the purposes of these meetings is to provide inspiration to community members. Weekly meetings, run by inmates, serve to introduce new members to the community as well as to update each other.***

Short (5 minute) "wing" meetings occurred twice daily in the TC: in the mornings and evenings. Offenders from different "wings" of the building (and different floors) gathered to share announcements and review the meals for the day. Members were asked to volunteer to lead the meetings, and to provide an inspirational phrase or story for members to start their day. Every meeting closes with the motto, "We are our brothers' keepers, and our goal is no more victims."

Weekly "House" meetings occurred every Thursday afternoon. Usually one member was placed in charge of running the meeting. During these meetings, new members were introduced to the community. Also, inmates reported to the community what consequences they received in the past week, and offenders placed on probation were assigned a support person, typically another member of the TC community. These meetings also provide a forum for announcements and speeches.

### (2) Rituals and Rites of Passage

According to De Leon, (2000, p. 91) celebratory occasions are used as "positive symbols of individual and collective change." Such occasions can include national holidays, specific program events such as anniversary dates, or landmarks for individuals such as the completion of treatment phases or graduations. Celebrations, traditions and rituals can serve the dual purposes of enhancing the cohesiveness of the community while reinforcing individual progress. Likewise, the TCA notes that components be structured "to address the common socialization and psychological needs of program participants."

Specifically, the TCA suggests “program participants and staff engage in meaningful program rituals, traditions and rites of passage” (Therapeutic Communities of America, 1999: Standard TC12).

***FINDING: The primary method of recognizing individual progress and marking occasions was through “announcements” made at the beginning of groups.***

We found that the primary method of recognizing individual progress in the TC was through “announcements” made at the beginning of many of the groups. Announcements provided an opportunity for inmates to share a variety of experiences. If an offender had a positive experience related to TC treatment, such as passing a polygraph, other group members provided supportive comments and applause, providing a “celebratory moment” on this progress.

However, announcements were handled differently depending on the group, the therapists, and the topic of the announcement. We saw many examples where offenders and therapists commented, encouraged, expressed concern, and provided useful input to those making the announcement. Examples of this were empathetic responses regarding medical or family issues. Therapists usually provided reflective feedback. In one instance, an offender admitted to experiencing anger over an issue in the TC, and the therapist gently but firmly suggested that the offender reframe his struggle with anger as a learning experience. The group then further explored the issue. Some groups tended to discourage announcements, but that was the exception rather than the rule.<sup>103</sup>

The SOTMP TC Polygraph Sanctions Grid Form (July 2000) describes suggested sanctions and privileges related to results of baseline and monitoring polygraphs completed while in treatment at the TC. While the Therapeutic Community intends to implement positive rewards for passed polygraphs (a significant landmark in treatment progress) as well as negative sanctions for failed polygraphs, Department of Corrections Administrative Regulations such as those related to safety issues have made it difficult to provide rewards to inmates. An offender may receive “movie night”<sup>104</sup> or “get out of group free” cards as rewards for passing the polygraph. While TC staff told us that the latter was not their preferred reward, implementation of other positive ways to congratulate offenders is difficult. For example, the TC intended to celebrate offenders who reach the Commitment Phase of treatment by holding a pizza party. Unfortunately, because of relatively recent restrictions regarding the delivery of outside food to the correctional institution, pizza could be ordered into the facility. Simple and timely acknowledgements of progress in treatment such as creating congratulatory posters with the names of individuals who move up a treatment stage are hard to implement because, as staff informed us, according to the American Correctional Association, posters are not allowed on walls unless they are framed. Such items as building frames require budgetary resources, and by the time requests are submitted and the frames built, the moment for immediate, positive feedback may be long past.

Responses from inmates we spoke with in focus groups indicated that these inmates valued feedback, and a little encouragement seemed to go a long way in terms of

---

<sup>103</sup> In a few groups we observed that therapists directed offenders to make announcements only “if they were important.” This occurred when the group was more didactic in nature.

<sup>104</sup> The offender is allowed to watch a movie from an appropriate list of titles. This reward was newly implemented during our evaluation.

positive benefits. One inmate described the importance of receiving congratulations from his therapist. "When you encourage a person in whatever they are doing, especially when there is some good, they change themselves, it helps that person continue to progress." Another told us that the occasional positive comment from his therapist kept him from giving up.

### (3) Work

According to De Leon (2000, p. 78) teaching a classic work ethic is a critical component of TC's. "Teaching the work ethic embraces the entire TC perspective, particularly the view of the whole person." The TCA shares this perspective. Standard TC3 states, "Work is used to support the program goals and to reinforce the sense of community and individual self-esteem."

***FINDING: The TC provides work that allows members to practice what they learn during group and in their community in a work setting.***

The TC provides work for the inmates through the greenhouse or the kitchen. They may also obtain jobs as porters. The day is structured to spend half the day working and the other half attending group therapy. The 40,000+ square foot greenhouse is designed to create a nurturing environment by working with plants and people and to teach vocational skills to the inmates. The kitchen allows them the opportunity to learn how to cook and bake. These jobs provide an chance for the inmates to take what they have learned in group therapy and in their community and practice applying the concepts in a work setting. Attaining the skills learned in the kitchen and greenhouse also enhances their marketable skill set to better prepare them for success upon release to the community.

***FINDING: Offender jobs sometimes have priority over treatment. Sometimes inmate issues were not addressed because the inmate involved was unable to attend group because of his work schedule.***

Some inmate issues were not addressed in a timely manner because the inmate involved was unable to attend group. We were told during interviews with several TC staff and facility administrators that it was necessary for us to understand that the facility was primarily a "work camp." We noted problems with inmate kitchen work schedules in that inmates working very early hours in the kitchen were sometimes tired and unresponsive during group. Greenhouse work schedules, while seasonal, also affected the ability of some inmates to attend group. Greenhouse workers were often needed for a full day, and when this occurred, these offenders engaged in little treatment.

TC staff is flexible regarding work schedules. Therapists told us that "work sites need to be filled" and that this was a DOC priority. Further, staff noted the importance of the greenhouse succeeding as an industry since it is seen as tied to the successful fate of the TC. However, several staff mentioned the difficulty of setting group schedules around work, and that sometimes this creates "scheduling nightmares."

### (4) Group Therapy (Process Issues)

The results in this section, as in the discussion of groups in the clinical principles components are based on our 67 group observations.

Although the issue of co-therapy is not addressed specifically by the TCA, perhaps because those standards are based on drug and alcohol programs, co-facilitation of groups is widely accepted and encouraged in sex offender treatment. According to the Colorado Sex Offender Management Board *Standards and Guidelines* (1999), group therapy should be co-facilitated by two therapists, preferably one male and one female to model appropriate and power-equivalent male-female interactions. Together, co-therapists can better manage the various responsibilities required for group therapy (for example, maintaining a record of group activities, assignments, and attendance), give each other support, and critique each other's group facilitation (Lowe, 2001).

The SOMB states that "the ratio of therapists to sex offenders in treatment groups shall not exceed 1:8. Treatment group size shall not exceed 12 offenders" (SOMB Standard 3.140C, p. 28). According to some experts, an ongoing sex offender treatment group should contain between two and seven members (Loss, 2001; Lowe, 2001). However, the ratio of eight members to one therapist was commonly used, according to CDOC's 50-state survey of prison sex offender treatment programs (Colorado Department of Corrections, 2000).

***FINDING: In accordance with both the literature and SOMB standards, most groups were co-facilitated and of the appropriate size.***

*Most (75%) groups we observed were co-facilitated. Of these, nearly half (45%) were co-facilitated by male and female therapists.*

The concept of co-facilitation is addressed in the 40-hour SOTMP training, which suggests that groups should be led by male and female co-therapists. Most (75%) groups we observed were co-facilitated. Of these, nearly half (45%) were co-facilitated by male and female therapists. At the time this research was conducted, 11 staff members were split almost evenly between male and female therapists. However, two of the male therapists also occupied the roles of TC coordinator and sex offender evaluator. This shortage of male therapists made it difficult to consistently comply with the practice of male and female co-facilitation, although efforts were made to do so whenever possible.

The groups we observed ranged in size from two to 17. Eleven of the 67 were comprised of more than the recommended number of participants (greater than 12). BOT and Cycle groups were those with the higher numbers of participants.

In three cases, the ratio of one therapist to eight offenders was exceeded. These groups were to be co-facilitated but were eventually facilitated with a single therapist. The therapist for one of these groups had been moved to another CDOC location the previous week, and in another case, a therapist left work early for a family emergency. In the third instance, the therapist was unable to attend, but we did not investigate the reason.

***FINDING: Some of the groups in the block schedule were cancelled. Several staff members told us that inmates are not always informed of these changes in the schedule.***

Eight group sessions were cancelled during our three-month observation period,<sup>105</sup> and one full day of groups was cancelled to enable TC staff to attend first aid training. Staff also reported through questionnaire responses that block schedules were generally, but not fully, implemented because the absence of a single staff person can affect the delivery of group services.

*The absence of a single staff person can affect the delivery of group services.*

We asked staff through our questionnaire how many of their groups were cancelled during the last month. Responses ranged from no groups cancelled (two people) to a third of the groups cancelled in the last month (one person). The other seven therapists replied that between one and four of their groups had been cancelled in the last month. During interviews, TC staff explained that group sessions were cancelled for many reasons including security issues, such as lockdown or discrepancies in “count,” (the prison practice of counting inmates to ensure that every inmate is accounted for). Others were related to therapist activities, such as team building, training, and other meetings. Sick leave and vacations also resulted in cancellations of group sessions.

*Sick leave and vacations also resulted in cancellations of group sessions. One group had not been conducted for six weeks because a therapist had fallen ill and required surgery. State budget deficits have resulted in the loss of 10 SOTMP positions in the last year, so staffing was at a minimal level, and this negatively affected service delivery.*

Several staff members told us that inmates are not always informed of these changes in the schedule. Not informing offenders of cancellations may be counter-productive to establishing behavioral norms that emphasize accountability and responsibility.

As mentioned above, one therapist was reassigned to another facility during our observations and we observed one instance where group coverage was affected by this reassignment. Also, during our observations, we learned that one group had not been conducted for six weeks because a therapist had fallen ill and required surgery. State budget deficits have resulted in the loss of 10 SOTMP positions<sup>106</sup> in the last year, so staffing was at a minimal level, and this negatively affected service delivery.

***FINDING: Of the 67 groups we observed that were scheduled for two hours or more, the average duration of groups was 86 minutes. Almost all of the 67 groups we observed started late, ended early or both. The block schedule did not accurately represent the hours of treatment offenders actually received.***

Groups should begin on time to set an example of responsible behavior (Loss, 2001).

The block schedule was organized so that groups were offered three times per day (8AM, 1 PM and 3 PM). Normally each therapist conducted one to two groups a day,

---

<sup>105</sup> Four Rational Office groups, two Rational Behavioral Training groups, one Crossover group and one Relapse Rehearsal group were cancelled during the times we observed groups. However, we observed groups only two weeks each month for three months. If groups cancelled when we were not there, they are not accounted for.

<sup>106</sup> Per communication with Program Director June 3, 2003.

however, some therapists were required to facilitate three groups in one day, two days out of the week, making it difficult for them to do paperwork or provide individual treatment on those days.

Few of the groups we observed started and/or ended on time. The logistics of moving around the facility made it impossible to conduct groups “back to back.” That is, if a therapist was scheduled to facilitate a group from 1-3 p.m., it would not be possible for that therapist to start a 3 p.m. group on time. This was especially the case if the group was held in a different location, facilitated with a different therapist, and/or included different offenders than the offenders that were in the previous group, all of which were likely during our observations.

Groups were sometimes delayed or shortened because of “count.” And prison activities sometimes interfered with treatment. For example, medical appointments and work schedules prevented offenders from attending groups. In one instance, group ended early because one member needed new shoes. Because this group was conducted at the greenhouse, which was located “outside the fence” during our research, the group was dismissed so all group members could move through secured gates together. Many groups were held at the greenhouse, and because inmates needed to be counted, moved through secured gates, and walk some distance from the facility, treatment time was shortened.<sup>107</sup>

Therapists were frequently observed to start groups after the time that they were scheduled. Groups also ended early on several occasions. Thus, we found that the block schedule did not accurately represent the hours of treatment offenders actually received.<sup>108</sup>

## (5) Other Treatment Elements

### *(a) Addressing Denial*

*According to Salter (1995) denial can be described as a spectrum of behaviors that includes denial of the acts, denial of fantasy and planning, denial of responsibility for the acts, denial of the seriousness of behaviors, denial of internal guilt, and denial of the difficulty in changing abusive patterns.*

“Denial is a central theme in the management of sex offenders” (English, Pullen, Jones, 1996, Chapter 4, p. 3). Offenders often refuse to admit their crimes or take responsibility for their unacceptable behaviors. According to Salter (1995) denial can be described as a spectrum of behaviors that includes denial of the acts, denial of fantasy and planning, denial of responsibility for the acts, denial of the seriousness of behaviors, denial of internal guilt, and denial of the difficulty in changing abusive patterns. Treatment providers in Colorado operate on the fundamental assumption that, before treatment can be effective, sex offenders must work through denial and admit to their sexual assaults and offending behaviors.<sup>109</sup>

<sup>107</sup> This problem should be remedied to some extent. A fence will be built around the greenhouse, which will eliminate the need to move through secured gates.

<sup>108</sup> We know of some instances where groups ended early so that offenders could work on homework.

<sup>109</sup> Marshall, et al (2001) describe the value of providing education and treatment to sex offenders who are in categorical denial, i.e., he or she categorically states they did not commit any sexual offense.



***FINDING: Offenders appeared to make progress in admitting more victims and/or behaviors over time.***

One of the treatment goals of the therapeutic community is to help offenders break through their denial. Even though an offender may admit to a specific crime, he may not admit to other crimes and behaviors. Eligibility to participate in the TC requires that offenders admit to sex offending behaviors and see those behaviors as current problems. Although there were no “deniers” groups, we observed numerous group situations where members addressed denial by confronting each other and challenging members to accept full responsibility for current and past sexually deviant behaviors. We found many examples where groups addressed issues described in Salter’s spectrum of denial. That is, although the offender may have admitted to current sex offending behaviors in order to be admitted to the TC, he may still have been in denial regarding other issues such as other victims, denial of behaviors relating to or preceding assaults, and minimization of the seriousness of the current crime or other sexual offending behaviors. We found numerous instances where the groups confronted these types of issues.

*We observed numerous group situations where members addressed denial by confronting each other and challenging members to accept full responsibility for current and past sexually deviant behaviors.*

Since we spent a period of several months observing these groups, and whenever we entered a new group, the members formally introduced themselves by discussing the crime and the number of victims harmed. This process meant that, in some cases, we were introduced to the same offender multiple times. It was interesting to note in a few instances that the introduction changed over time to include more victims. For instance, on first meeting one offender, he described his crime as an assault on his wife. Later, this same offender included assaults on children and their age groups in his introduction.

*(b) Polygraphs*

The SOMB *Standard* 3.730 (2001:41) requires that sex offender treatment providers utilize polygraph assessment and monitoring of offenders.

***FINDING: Polygraphs are used throughout the offender's stay in the TC to determine whether he is participating in high-risk behaviors.***

The therapeutic community staff began using polygraphs in 1996. The polygraph protocol is standardized and outlined in a specific polygraph manual.<sup>110</sup> Staff began using sanctions in 1998, and a grid that details sanctions for deceptive and inconclusive polygraph results was fully implemented by 1999.<sup>111</sup> These changes indicated a significant modification of the program.

---

<sup>110</sup> The manual outlines the procedures to be used for the polygraph in conjunction with developing the sex offender’s history of behaviors and victims, as well as information on the sex history questionnaire and disclosure forms completed in therapy, and the schedule for conducting polygraphs.

<sup>111</sup> The Sanctions Grid includes sanctions for deceptive and inconclusive polygraphs and is included in Appendix M.

*The disclosure polygraph assists staff in determining the range and frequency of the offender's past sex offending behavior. This information is used to develop relapse prevention plans and conditions of community supervision.*

The polygraph is used as part of the treatment process to verify inmates' full disclosures of sexual history. Four failed disclosure polygraphs result in termination from the program as does two failed maintenance polygraphs. The disclosure polygraph assists staff in determining the range and frequency of the offender's past sex offending behavior. This information is used to develop relapse prevention plans and conditions of community supervision. Once the past sexual offending behavior has been established the offender is given a monitoring/maintenance polygraph every six months to help determine if he is engaging in high risk or offending behavior.

*Although inmates have four opportunities to pass a disclosure polygraph and two opportunities to pass a maintenance polygraph, inmates tended to perceive terminations associated with polygraph failure as unfair.*

Both staff (through interviews) and inmates (through focus groups) informed us that many offenders are terminated because of deceptive polygraph results. Most of the inmates participating in focus groups complained about terminations resulting from failure of the polygraph. Although inmates have four opportunities to pass a disclosure polygraph and two opportunities to pass a maintenance polygraph, inmates tended to perceive terminations associated with polygraph failure as unfair. Focus group members said they would like to see the polygraph used more therapeutically rather than punitively.

*One inmate stated that although he did not like the polygraph, it did help him.*

*Another inmate described the polygraph as the "best tool" in the program because it promotes honesty.*

One inmate stated that although he did not like the polygraph, it did help him monitor his behaviors because he knew he would eventually be tested about those behaviors. Another inmate described the polygraph as the "best tool" in the program because it promotes honesty. An inmate from a focus group admitted that when he was new to the program he was angry about and afraid of the polygraph. But he stated that, "If there wasn't some sort of accountability to bring out truth then we would never get it. The polygraph is the only tool this program has to hold us accountable."

We talked to three offenders recently released from prison to community corrections programs to ask, among other things, what they thought of the polygraph as a treatment and supervision tool. Despite some objection to it, each of the three offenders thought the polygraph was useful. Here is some of what they told us:

"It's a good monitoring tool for me...It holds me accountable especially with female children, I know if I decide to do something I would get caught. It holds me accountable. It's a good tool."

"It's effective in getting me to tell the truth. I don't believe it's all that accurate. I doubt the validity, but it is real effective for me to tell the truth when going in [to take the test]."

"I don't like them." But he then added, "It's an effective tool to be honest because of the consequences...so every time I felt like breaking a rule or taking something, I would always think about the polygraph. I feel like it invades my privacy."

## Component 7. The TC Process

According to the TCA, “Socialization and personal growth occurs when individuals meet the community expectations of participation in all program activities and all social roles” (Therapeutic Communities of America, 1999: 9). Standard TP2 specifically notes that senior members should take responsible roles in relation to junior members of the community. For instance, senior members should play a primary role in the orientation of new community members. Several standards underscore the importance of peer feedback and help received both formally and “through informal interactions through the course of daily activities” (Standards TP3 through TP8). Many of the issues related to the TC process have been addressed earlier in this report, as many components of service delivery (clinical principles, TC program elements, and others) are inexorably intertwined.

***FINDING: Senior group members assist new group members by teaching them how the group operates, laying out group expectations, modeling behaviors and participation, and providing them with other information needed for successful functioning in the group.***

Many of the groups provided at the TC are ongoing. That is, group members do not start and finish at the same time, and inmates participate for differing lengths of time. For example, during the Basic Orientation Training (BOT) phase of the TC, inmates participate in a group that focuses on Criminal Thinking Errors (CTE), Foundation Thinking Errors (FTE), and tactics that are used in their life styles and offending patterns. Group members are integrated into the group as they begin the program and thus start the group at varying times. They stay with the group until they learn all CTEs, FTEs, and tactics, which takes approximately 6 months (as long as they comply with the overall TC requirements). In many groups we observed, new members learned how the group operates from senior group members. During one observation, introductions, rules, and a description of the group were made for the benefit of a new member. The new members had an opportunity to observe the activities of the group and learn the expectations before fully delving into the group therapy process. In another example, we observed a new group member watch as other inmates presented in Cycle group, which handles the difficult work of scrutinizing the patterns of behavior that lead to offending. As the work of the group proceeded, the new member was educated about the type and level of work required for participation in this group. This appeared to be an effective approach for introducing the inmate to the complexities and requirements of the group.

Other times, the therapist explained the group process to the new member, and all other inmates introduced themselves and briefly presented their issues. Several of the inmates advised the new member on the specifics required for the group, such as handing “pull-ups.” New members had the opportunity to learn the concepts discussed in the group by listening to how they were used by senior group members. We also observed inmates offering advice and help to new TC members outside the group.

## Component 8. Stages of Treatment

The TCA suggest that stages of treatment should be structured to facilitate a developmental process of change. “Meeting the goals and objectives of prescribed program phases facilitates internalized learning until the individual actually incorporates a new identity which is consistent with the principles of right living” (Therapeutic Communities of America, 1999: 10). Due to a variation in offenders’ risk levels, progress, and program characteristics, offenders move through phases at different paces (Loss, 2001).

*Stalling out in a given phase or level is clearly linked with not meeting program requirements, and moving to a higher level becomes an important measure of progress.*

According to De Leon (1995), programming should be phased to allow program participants to move forward. This means certain activities and assignments should occur at explicit stages during the treatment period so inmates know where they stand in relation to the entire set of program expectations. Stalling out in a given phase or level is clearly linked with not meeting program requirements, and moving to a higher level becomes an important measure of progress. This gives inmates the opportunity to feel a sense of accomplishment that will motivate them to continue working in treatment.

***FINDING: The program design is consistent with standards and recommendations in the literature—there are five clearly defined, successive levels of treatment.***

The SOTMP Resource Guide<sup>112</sup> provides a description of five successive levels of treatment (see Table 6 on the following page), and this follows recommendations in both the TCA standards and the literature that state that successful treatment includes phased programming.

---

<sup>112</sup> Sex Offenders: Myths, Facts & Treatment: A Community Outreach Project and Resource Guide, Sex Offender Treatment and Monitoring Program, Colorado Department of Corrections, 2001.

**Table 6: 2003 Therapeutic Community Treatment Levels**

| Treatment Levels   | Brief Description   |
|--|---|
| Assessment Phase<br>(sometimes referred to as the Basic Orientation Level) | Focus on learning, identifying, and changing thinking errors. Learn the expectations of living in a therapeutic community and begin participation on a task team (for instance an educational task team could focus on educational needs in the community or of a particular individual. The team would decide on projects to aid in education). Participate in recreational therapy.   |
| Orientation Level <sup>113</sup>   | Inmate cooperates in the development of and commitment to his individualized treatment plan, completes his sex history, identifies his victim pool and grooming tactics and takes a baseline polygraph. Orientation also consists of participating in several groups such as Basic Orientation Training (BOT), Rational Behavior Training (RBT), Journaling, and Concept groups. (See Table 5 for a description of these groups.) |
| Commitment Level   | The offender completes a personal change contract, <sup>114</sup> identifies a community support system who will participate in family education, and discloses their sexual history and personal change contract (PCC) <sup>115</sup> to their identified support system.  |
| Senior Level   | Offender must complete a victim clarification project, continues to attend Journaling Process group and Relapse Rehearsal group, and undertakes community service activities. <sup>116</sup>  |
| Maintenance Level  | Offender participates in Relapse Prevention Rehearsal group, Maintenance group, Journaling, and specialized seminars. Inmates stay in this phase of treatment until they are accepted into community corrections, discharge to parole, or terminate.  |

***FINDING: Administration, staff and inmates expressed concern about the difficulty of moving through the program.***

Many participants leave the program before moving through all of the phases, that is, some offenders drop out, are terminated or paroled before finishing the program. Several DOC administrators commented on the perceived lack of progress of offenders moving through the program. One administrator commented, "They don't need to stay in the TC for 10 years." Another noted that the program needed "more positive reinforcement" (benefits and rewards). Some were confused by the notion that the "orientation" phase of a program would take two or three years for the offender to

<sup>113</sup> What was called the Orientation Level at the time of our evaluation is now referred to as the Change Level.

<sup>114</sup> The Personal Change Contract describes each phase of the offender's cycle of offense and how he plans to recognize and intervene in these behaviors.

<sup>115</sup> The Personal Change Contract that was in the Commitment Level at the time of our evaluation is now started during the Change level.

<sup>116</sup> Community service activities have included the development of written material that explain to school staff and parents how sex offenders groom children. These powerful descriptions can be found in the SOTMP resource guide titled Sex Offenders: Myths, Facts & Treatment: A Community Outreach Project and Resource Guide, 2001.

complete. And, as one administrator noted, "why spend money on a program if they aren't getting through?" Some staff told us expectations of program participants were high, and "we give up on them too easily when they make mistakes...."

*Offenders having difficulties keeping pace with a group can be referred to their primary therapists or other community members for special help or given extra assignments.*

*Several staff reported that they try to work with the individual to get them through these rough spots.*

Offenders having difficulties keeping pace with a group can be referred to their primary therapists or other community members for special help or given extra assignments. If lack of progress is due to resistance to treatment, the inmate may be terminated. However, several staff reported that they try to work with the individual to get them through these rough spots. Sometimes addressing these individual differences among inmates slows the group down. Presentations are sometimes stopped so the person can catch up, and the entire group can be held back for several sessions. The group becomes part of the process in working with offenders, and sometimes the group members get frustrated.

One of the most common themes that surfaced during our focus groups with offenders was that they did not see signs of program success. They expressed frustration over the fact that inmates do not graduate or finish the program. Inmates in the program know others have been in the program for years and begin to feel discouraged. Offender

*"I don't see anybody ever getting paroled. I don't see anybody ever getting into the halfway house."*

comments included "I don't see anybody ever getting paroled. I don't see anybody ever getting into the halfway house." "The percentage of somebody graduating this program is zero." Some inmates stated that they think about quitting because at Fremont (where they would be transferred to) they can see their family. During the three months we spent at the TC, we learned of only one inmate who had reached senior level.

However, lack of movement through the program levels does not interfere with community readiness. Offenders are considered eligible for placement in the community when they reach the second level. To be recommended for release, offenders must pass a disclosure polygraph and identify a support person who will be informed of the offender's complete sexually abusive history and the corresponding risk management plan.

Despite their frustration over their lack of progress in the program, the majority of inmates we spoke with agreed that they learned a lot at the TC and benefited from the program, but would like to see more tangible success (i.e., movement through the program). "There needs to be some success here. There has to be some movement into the community." "There is stuff to be learned, I learned a lot. It would be nice to see the light at the end of the road somewhere."

We held a focus group with inmates who had been at the TC and returned to the Fremont facility because they quit or were terminated. These inmates told us of negative feelings from inmates at the Fremont facility regarding the TC because some of the residents who have been terminated return to the general population in prison and make negative statements about the program. Seeing inmates from the TC return to the general prison population discourages general population inmates from applying for the program. As one said, "It's like going to a college and no one ever graduates. That's a hopeless feeling."

Inmates described the need for more positive incentives and more positive feedback from therapists. One inmate remarked that the occasional positive feedback from his therapist kept him motivated, that a little bit of encouragement seems to go a long way, and many of the others in the focus group agreed. For the inmates we spoke with, positive reinforcement from their therapist was a critical aspect of their treatment experience. Similarly, criticism from the therapists is discouraging. As one inmate said, "It's the little put downs, the little slights." It is difficult in a program that keeps inmates accountable and under constant scrutiny to remember to reward progress and positive steps, no matter how small. This is especially true when the program must work from a "non-trust" premise. But the responses show that support and encouragement have an important motivating influence on these offenders.

Interestingly, when we asked TC staff for their measures of program success, therapists provided examples of both program and inmate success. While some mentioned completing the program, most had other definitions. Among these were reduced recidivism and fewer victims, reapplying to the program after being terminated, learning more about the offenders' behaviors, increased participation and feedback in groups, increased inmate confidence and self-esteem, measures of positive change on assessments, and staff retention.

## **Component 9. Community TC and Clinical Management**

The psychological and physical safety of the community is the responsibility of both program participants and staff. Therefore, management of offender behavior requires full involvement by all TC members (Therapeutic Communities of America, 1999: 11). Participants are expected to engage in the continual scrutiny of each other's behavior and attitudes. One way to manage the safety of the community is by having written behavioral norms that govern participant behaviors (Therapeutic Communities of America, 1999: Standard CM1).

### **(1) Treatment Contracts**

Behavioral contracts specify safety and behavioral rules for offenders who participate in the treatment. A treatment contract is thought to be helpful in encouraging an individual's compliance with the program rules (Winick, 1991) and the document usually captures treatment principles and translates these into expected behaviors. According to Lowe (2001) and Loss (2001), contracts should be specific to ensure that offenders understand the rules and will be less likely to manipulate them. In a correctional setting, contracts are likely to have special conditions such as offenders being expected to notify staff if they witness another group member violating the contract (Loss, 2001). Standards from the TCA require that participants enter into treatment contracts which include contingencies for behavioral consequences (Standard CM8, 1999), that there are written behavioral norms which govern participant behavior (Standard CM1, 1999), and that there are written "cardinal" rules (no sex, violence, substance use, etc.) which, if violated may result in termination (Standard AD11, 1999).

**FINDING: The SOTMP Therapeutic Community's treatment contracts were consistent with the 1999 TCA Standards and outline responsibilities of the offender and the therapist.**

Inmates must sign a standard treatment contract and agree to its conditions before being accepted into the TC. The contract lists all of the expectations an offender must meet while he will be in the TC. The contract specifies cardinal and basic rules for participants, circumstances for termination, confidentiality rules and responsibilities of both the inmate and the therapist.<sup>117</sup> Offenders are made aware that the consequence for violating the cardinal rules (no use of drugs or alcohol, no violence or threats of violence, no stealing, no sexual acting out, and no violating confidentiality) results in termination. The contract lists the consequences for violations and states that every aspect of the inmate's life and behavior is subject to scrutiny in the TC. Inmates must agree to having their mail, reading materials, and pictures in their rooms approved by staff, not being able to choose their roommates, knowing their roommates may be switched, and that their rooms are subject to contraband searches.<sup>118</sup> They also agree to submit to psychological testing, drug and alcohol screening, plethysmograph or Abel assessment, and polygraph examinations in order to remain in the community.

*The cardinal rules include no use of drugs or alcohol, no violence or threats of violence, no stealing, no sexual acting out, and no violating confidentiality.*

## (2) Termination and Suspension

Termination and suspension from the program is necessary when offenders have committed the most serious violations<sup>119</sup> or when they have established clear patterns of disruption, despite treatment efforts or suspension (Loss, 2001).

**FINDING: Despite perceptions from some inmates that termination from the program may be unfair, the policy on terminations and suspension is clearly stated in the treatment contract. Staff also informed us that offenders are given numerous opportunities to succeed before they are terminated.**

*It is not possible to separate inmate's sense of disappointment when terminations occur from the actual reasons a "brother" is terminated from the program.*

Although the treatment contract states that an inmate can be terminated for breaking the cardinal TC rules,<sup>120</sup> he may also be terminated, on the "clinical discretion of the treatment team" for breaking basic or other TC rules. According to information obtained during focus groups, and discussed previously in this report, some offenders perceived unfairness in the way terminations were implemented. Some inmates said that while they do not want people in the community who "don't want treatment," they see some inmates terminated for small infractions, while others committing larger infractions stay. The inmates also discussed their frustration over the number of terminations and

<sup>117</sup> A copy of the treatment contract is provided in Appendix I.

<sup>118</sup> In conjunction with correctional staff, the program staff screens belongings and conducts "dorm runs" to minimize the presence of contraband and drugs (Standard CM12). While we were at the TC we observed three room searches.

<sup>119</sup> Serious violations include sexual aggression or harassment, violence or threats of violence, patterns of manipulation, exploitation of others, contacting the victim, compromising safety rules, non-participation in treatment or interruption of the group process.

<sup>120</sup> See Appendix O for a list of Cardinal, Basic, and Other Rules.



their sense of failure when these occur. Although there was a clear sense of confusion about the termination process, it is not possible to separate inmate's sense of disappointment when terminations occur from the actual reasons a "brother" is terminated from the program.

We observed several meetings where therapists discussed inmates who were to be terminated from the program. In each situation, the offender either broke a cardinal rule (such as fighting) or was on probation (or notice) and given multiple chances to resolve a particular issue. We were also aware of several other terminations that occurred during our evaluation, and these were for violations as described in the contract (e.g., physical force, extreme non-compliance with treatment, sexually acting out).

## **COMPONENT 10. Intake Screening and Assessment**

It is essential to assess the primary problem area of participants admitted to the program (Therapeutic Communities of America, 1999: 12). According to Lowe (2001) and Przybylski and English (1996), defining the population to be served is a vital first step to program implementation success. Once the population has been defined and selected for participation, the next step is to assess their individual and common needs in a systematic process. TCA Standards state that participants and staff should clearly acknowledge and identify the common personality and behavioral traits to be shared by all (1999: Standard T5). Once a program has identified the needs of the clients, it is important for the program to determine how to meet the needs of the client population rather than requiring the clients to fit the program (Lowe, 2001).

### *(1) Sex Offense Specific Evaluation*

The Sex Offender Management Board *Standards and Guidelines* require a comprehensive mental health sex offense specific evaluation on each offender participating in treatment (SOMB, 1999: 17).<sup>121</sup> Furthermore, the TCA recommends that a thorough assessment be done within ten days of admission (1999: Standard). Initial assessments of new clients involve the consideration of demographic, historical, and clinical factors (Lowe, 2001). Thorough assessment is necessary to determine treatment and security needs of offenders, assess effects of treatment, estimate risk of re-offense upon release, (Marshall and Williams, 1998) and determine treatment amenability (Mussack & Carich, 2001).

***FINDING: An array of assessments and questionnaires were used to evaluate offender needs. However, because the evaluation was not often conducted when the offender began treatment in the TC, it was not regularly used to guide the treatment plan or the way the individual therapist worked with the client.***

After an offender is admitted to the SOTMP program, staff administers a battery of tests and questionnaires to define the client population and evaluate the offenders' treatment needs.<sup>122</sup> Upon entry to Phase I, offenders who have been sentenced to lifetime supervision are given a sex offense specific evaluation per the SOMB *Standards and*

---

<sup>121</sup> This is in accordance with Section 16-11-102(1)(b) C.R.S.

<sup>122</sup> Appendix P describes which tests are administered at each phase of treatment along with a brief description of each.

*Guidelines* (1999). All offenders are given two personality tests.<sup>123</sup> Other tests are also administered in Phase I.<sup>124</sup> Phase I offenders repeat these assessments to measure change and progress when they complete the six-month program.

Unless completed in Phase I, everyone entering the TC receives a SOMB-described sex offense specific evaluation. This evaluation includes an in depth sexual history and cognitive evaluations, the Wechsler's Adult Intelligence Scale,<sup>125</sup> personality tests, the Abel screen (Abel, Revised June 2001), polygraph sexual history exam, drug and alcohol history, and overall mental health information.

During interviews, staff informed us that they completed the assessments throughout the time of the offender's stay in the program, not necessarily at intake. In fact, these evaluations are often not done until right before a person leaves the program. The treatment plan, therefore, is not necessarily based on "the needs and risks identified in current and past assessments/evaluations of the offender."<sup>126</sup> According to interviews, additional special testing is done when needed, such as when an offender presents a neurological complication. Specialized staff is employed to conduct sex offender evaluations.

## (2) Risk Assessments

Risk assessments are typically used to determine the likelihood that an offender will commit another offense. The Office of Research and Statistics developed an actuarial risk assessment scale on a population of convicted sex offenders in Colorado, and SOTMP clients were included as part of the original sample. Some of the risk factors include criminal history, being employed less than full time at arrest, failing first or second grade, possessing a weapon during the current crime, use of drugs or alcohol during or immediately prior to the crime, and not being sexually aroused during the sexual assault.

***FINDING: Although the treatment manual states that offender risk should be evaluated using the actuarial scale developed by DCJ's Office of Research and Statistics, several staff reported that while they have criteria for risk, they do not use a risk assessment tool.***

According to interviews with treatment staff, the criteria for risk include age of onset, number of victims, use of a weapon, paraphilia involved, and criminal history. This information is typically gathered during the sex offense specific evaluation. (However, as noted above, the evaluation may take place throughout or at the end of the offender's

---

<sup>123</sup> The Millon Clinical Multiaxial Inventory-III (MCMI 3) (Millon 1994) and the Personality Assessment Inventory (PAI) (Morey, 1991).

<sup>124</sup> The Multi-Phasic Sex Inventory (MSI) (Nichols and Molinder, 1984), Locus of Control (LOC) (Lefcourt, 1991), Balance Inventory of Desirable Responding (BIDR) (Lefcourt, 1991), the Empathy for Women 2A (Hanson, 1995), Child Empathy Test, Version 2 (CET-2) (Hanson, 1999), and the Relationship Questionnaire (Hanson, 1992).

<sup>125</sup> Wechsler, Third Edition, WAIS III, 1999.

<sup>126</sup> Sex Offender Management Board Standard 3.130, p. 27.

stay at the program, not necessarily when he enters the program.)<sup>127</sup>

## Component 11. Community-Based Aftercare: Parole and Community Corrections

Research supports the importance of aftercare (treatment and supervision) as a critical element in helping offenders remain crime free (Lipton, 2002; Simpson, Wexler and Inciardi, 1999; Martin, Butzin, Saum and Incardi, 1999; English and Woodburn, 2002). TCA's Revised Prison Standards that address treatment provided in therapeutic communities recommend appropriate community-based aftercare for at least six months after release from prison. This recommendation is based on "research [that] clearly demonstrates the importance of aftercare programs to maintain the positive gains made in the prison TC" (Therapeutic Communities of America, 1999:12). Indeed, the ORS recently completed a comprehensive study of the state's community corrections system and found that offenders who were *not* placed on post-release (from the halfway house) supervision were nearly twice as likely to re-offend when compared with offenders released from halfway houses who *did* receive supervision. Moreover, the non-supervised offenders who were rearrested for a new crime failed significantly sooner than those who were supervised and rearrested (English and Woodburn, 2002).

*The ORS recently completed a comprehensive study of the state's community corrections system and found that offenders who were not placed on post-release (from the halfway house) supervision were nearly twice as likely to re-offend when compared with offenders released from halfway houses who did receive supervision (English and Woodburn, 2002).*

TC members leave the program in several ways. As discussed previously, they may be terminated and sent back to other facilities or they may complete their prison sentence and be discharged directly into the community without supervision or other resources. But for those who leave the TC program and transition to supervision in the community, there are two different ways this can happen and these are described below.

Offenders in Colorado can exit prison and be placed on supervision in the community via *parole supervision* or *community corrections*. The first of these requires that the parole board specifically grant an offender's request for parole supervision in the community. Offenders must agree to specific supervision conditions and, once released, specially trained parole officers use increased surveillance, treatment and supervision contracts, and polygraph monitoring to manage this group of offenders.<sup>128</sup> According to the *SOMB Standards*, as soon as possible after the referral of a sex offender to parole, a treatment team should be convened to manage the offender during his/her term of supervision. "Supervision and behavioral monitoring is a joint, cooperative responsibility of the

<sup>127</sup> Another form of assessment is conducted on all inmates at the Denver Reception and Diagnostic Center (DRDC) upon entry into DOC. Each inmate receives a code based on his criminal history and crime of conviction. The resultant "S-code" can range from S5 (past or current felony sexual offense conviction) to S1 (no history or indication of sex offense behavior). These codes are described in more detail on p. 41 of the Methods section of this report.

<sup>128</sup> In 1998, the General Assembly enacted C.R.S. 18-1.3-1001 concerning lifetime parole supervision for certain classifications of sex offenders. This legislation specifies a period of parole for sex offenders convicted of class 4 felonies to be an indeterminate term of at least 10 years to the remainder of the sex offender's natural life. The period of parole for sex offenders convicted of class 2 or 3 felonies is an indeterminate term of at least 20 years and a maximum of the remainder of the sex offender's natural life.

supervising officer, the treatment provider, and the polygraph examiner”<sup>129</sup> (Colorado Sex Offender Management Board *Standard* 5.110B). The SOMB standards of sex offender supervision apply whenever the factual basis of a crime involves a sex assault.

Transitioning to the community via the statewide community corrections program is a different process involving different decision-makers. Moving an offender onto community status is a result of decisions made by DOC officials (not the parole board) who are guided by internal policies and legislatively mandated criteria that define eligibility for community release. However, once offenders are approved for community status, entrance into one of the 33 halfway house facilities across the state requires approval by the local community corrections board and also the halfway house program director. By statute, community corrections boards exist in each judicial district and

members consist of criminal justice professionals and at least one member of the public. These boards are empowered to review every case referred by the court and the DOC and accept or reject the placement of the offender in a halfway house in its jurisdiction. Program directors of halfway houses also have the authority to reject cases. Sex offenders referred to community corrections programs are frequently rejected by either the local board or the program director. In our recent evaluation of community corrections (English and Woodburn, 2002), only 1% of offenders accepted into community corrections programs were sex offenders.<sup>130</sup>

*Sex offenders referred to community corrections programs are frequently rejected by either the local board or the program director. In our recent evaluation of community corrections (English and Woodburn, 2002), only 1% of offenders accepted into community corrections programs were sex offenders.*

To learn more about the transition component of the SOTMP, researchers interviewed directors and staff from two community corrections facilities that offer transition services to sex offenders from the Therapeutic Community. We also interviewed DOC administrators to gain insight into the transition process.

### (1) Aftercare – Parole

As noted earlier in this report, the Colorado General Assembly passed legislation in 1992<sup>131</sup> that created a Sex Offender Treatment Board to develop standards and guidelines for the assessment, evaluation, treatment and behavioral monitoring of sex offenders. The *Standards and Guidelines for the Assessment, Evaluation, Treatment and Behavioral Monitoring of Adult Sex Offenders* were developed over a period of two years and first published by the Board in 1996. These *Standards* are based on the best practices known today for managing and treating sex offenders, and have been revised twice (1998 and 1999)<sup>132</sup> with another revision scheduled this year to keep current with the developing literature in the field of sex offender management. The *Standards* describe a coordinated system for the management and treatment of sex offenders to enhance the safety of the community and the protection of victims.

<sup>129</sup> In Colorado, the polygraph is used as one tool in supervision to combat the reluctance to disclose information necessary for effective monitoring.

<sup>130</sup> Ironically, when cases are not accepted into the structured setting of a halfway house, many offenders then serve probation or parole sentences in the same jurisdiction.

<sup>131</sup> C.R.S 16-11.7-101 to 16-11.7-107

<sup>132</sup> Colorado Sex Offender Management Board (Revised June 1999). Standards and guidelines for the assessment, evaluation, treatment and behavioral monitoring of adult sex offenders. Denver, CO: Colorado Department of Public Safety, Division of Criminal Justice, Office of Research and Statistics.

For sex offenders on parole, continued intensive treatment as well as specialized supervision are coordinated through specially trained Risk Assessment Management (RAM) officers, SOMB-approved community treatment providers and polygraph examiners. Researchers conducted a focus group with twelve RAM officers from around the state to find out how they perceived the Therapeutic Community.

***FINDING: Parole officers unanimously agreed that the TC improved communications between parole and the prison facilities. Officers reported that the information they receive from treatment providers is useful in assessing risk and managing the offender.***

The twelve RAM officers we spoke with unanimously agreed that the therapeutic community improved communication between parole and the prison facilities. One officer remarked on the usefulness of receiving background information from therapeutic community providers that describes specific offender issues. Another commented that because parole officers quickly receive the information they need from the TC, parolees start their supervision and treatment assessments within a week after release from prison. Apparently, this level of communication does not exist when non-TC sex offenders leave prison for parole. The group discussed frustration when case managers for non-TC sex offenders do not have all the information necessary to allow officers to develop treatment and supervision plans immediately. For example, sometimes the prison case manager (for a sex offender who did not participate in treatment) lacks police reports and relies on the offender to describe the crime. Because the sex offender has not received treatment, the self-report will likely conflict with the information stated in the police report, particularly regarding sexual details. However, according to the SOMB Standards, if the factual basis of the crime includes a sex assault, the parolee needs to be managed as a sex offender, regardless of the crime of conviction.

*Because parole officers quickly receive the information they need from the TC, parolees start their supervision and treatment assessments within a week after release from prison. Apparently, this level of communication does not exist when non-TC sex offenders leave prison for parole.*

*If the factual basis of the crime includes a sex assault, the parolee needs to be managed as a sex offender, regardless of the crime of conviction.*

***FINDING: Parole officers perceived definite benefits of TC treatment.***

The parole officers who took part in the focus groups were very supportive of the therapeutic community. They perceived many specific benefits. One parole officer stated, "It's like night and day when you have a guy from the TC ...because they can sit down and talk to you about their triggers, safety plans, etc." Another officer commented, "they are just so much further ahead." Offenders involved in the therapeutic community have admitted their current offense (and probably much more), and they have worked on denial issues. One DOC officer commented on the increased ability of TC participants to recognize their own risk behaviors *before* they commit and office "[TC] offenders...recognize deterioration. They know when they are going downhill. The TC isn't an easy program. If they've made it to the community, there is a commitment to change their behavior. "As was mentioned above, TC participants have also been operating under SOMB Standards, which include requirements/restrictions they would otherwise not have been introduced to had they not participated in treatment. This includes experience with the post-conviction polygraph examination. For

*One parole officer stated, "It's like night and day when you have a guy from the TC ...because they can sit down and talk to you about their triggers, safety plans, etc." Another officer commented, "they are just so much further ahead."*

supervising officers, this translates into a case that is considerably easier to manage compared to sex offenders who received no treatment in prison and so had exposure to none of these things.

Further, regarding denial specifically, the SOMB *Standards* require offenders who remain in denial six months after the start of supervision to be terminated and returned to prison. Sex offenders who did not participate in prison treatment may have been denying their crime for many years. This entrenched denial may take longer than six months to crack. Those offenders who remain in denial and who committed crimes before mandatory parole was enacted are likely to return to prison and finish their sentences there, eventually returning to the community with no supervision.

***FINDING: Inconsistencies in administrative policies between sex offenders who do and do not participate in prison treatment make parole cases harder to manage. According to the officers, transition from prison to parole is more difficult when sex offenders have not received treatment. Parole officers spend considerable time orienting offenders to the rules that apply to parole but did not apply to them in prison.***

The officers discussed the fact that sex offenders who have *not* participated in any aspect of the SOTMP are completely unprepared for the restrictions and expectations associated with the SOMB standards due to the inconsistencies in administrative policies applied to sex offenders in prison. For instance, those who volunteer for treatment, compared to those who choose not to engage in treatment, are subject to different rules. In particular, the officers mentioned that offenders who are not receiving treatment in prison are visiting with and making phone calls to their children and sometimes to the victim of their crime(s), while those in treatment cannot. But in most cases, paroled sex offenders will not be allowed to live with children, and usually will lose in-person contact with their own children until all SOMB evaluations are complete and treatment is well underway (see SOMB *Standard* 5.7). This restriction represents a significant change and parole officers must deal with the offender's frustration. An officer remarked that since inmates were permitted contact with their children for four or five years while in the facility, they do not understand why they may have no contact while on parole. Officers also see the frustration of offenders who were charged with a sex crime

*An officer remarked that since inmates were permitted contact with their children for four or five years while in the facility, they do not understand why they may have no contact while on parole.*

and convicted of a non-sex crime since the SOMB standards also apply to them. Additionally, some adult victims of offenders not in treatment visit the offender while in prison,<sup>133</sup> and several RAM officers told us that in some cases, the offender applies to live with the victim after release from prison, which SOMB standards does not allow.

The officers voiced concerns that corrections administrators are not well educated about the sex offending population, and this contributes to the inconsistencies in policy. The officers also suggested that an "offender orientation" class occur before release so offenders are told what to expect when they are on parole.

---

<sup>133</sup> We learned from several sources that Visitor Lists are not always thoroughly checked.

***FINDING: When the RAM team was initiated two decades ago to provide specialized, coordinated services to high-risk offenders, it was designed to have small caseloads. However, in recent years the caseload size has grown quite high and this results in a decrease in supervision resources available to each case.***

Some of the focus group participants commented that they only had a small portion of sex offenders from the therapeutic community. For one officer this was five of 47 sex offenders (among other offenders) on his caseload. The theme of large caseloads, in general, emerged as a problem. One officer noted that he had a caseload of ninety; 50 were sex offenders and 35 were offenders with serious mental illness.

Officers remarked that their workweeks were typically more than 40 hours and that everyone was overloaded. “You learn to pick out those in trouble,” one officer told us. In other words, the overload forced them to triage cases and work only with those who were already in trouble, not motivated, or in jail, rather than working closely with all offenders on their caseloads to help them transition successfully. Offenders motivated to change often get ignored in this scenario. One officer described a situation where a seriously mentally ill offender took two full days of his time because she had been jailed, leaving little time for him to monitor and encourage sex offenders who are motivated to change.

*Officers remarked that their workweeks were typically more than 40 hours and that everyone was overloaded.*

***FINDING: The officers described a lack of consistent, relevant, and timely training.***

Those officers who attended a 40-hour training in sex offender treatment and monitoring provided by and for therapists of the SOTMP found little of the information to be pertinent to supervision concerns. Some had attended trainings offered by probation, but this opportunity had not occurred in many years. Officers would like more information on ways to monitor sex offenders, what to look for in their homes, and other supervision issues. One person remarked that he and another officer in the group attended the 40-hour SOTMP training 18 months after he started working with sex offenders. Another chimed in that he attended this training four years after he started as a RAM officer.

***FINDING: Officers told us it was sometimes difficult to meet as a team or to get backup from supervisors, who are often not trained in sex offender issues.***

RAM officers’ workloads make it difficult for them to meet as a team. They told us it is also difficult to bring in officers from various parts of the state, “...especially in rural areas—[it] takes a couple of days [and you] can’t afford to lose two days in the La Junta office because *you’re* the La Junta office.”

Most supervisors have never worked a RAM case so, according to this group, they don’t know the issues involved with sex offenders. This makes it harder for officers to get support or even have back up. A RAM parole officer who did not attend the focus group confirmed this. He also told us that RAM officers are often supervised by non-RAM supervisors because the number of sex offenders released to parole has increased, while few parole officers have an interest in supervising sex offenders. This results in a situation where there are too few officers (or supervisors) to fully cover all sex offenders on parole. We learned that parole officers become RAM officers through a volunteer

process. Parole is now considering a draft process for officers even remotely interested in this area of expertise. However, there is concern about providing training to these officers as recent budget cutbacks have resulted in cutting training dollars.

## (2) Aftercare - Community Corrections

Phase III of the SOTMP consists of community supervision by DOC's specially trained Risk Assessment Management (RAM) team. This effort is designed to provide specialized community corrections placements in a halfway house, intensive sex offender specific treatment by a provider approved by the SOMB, specialized supervision, and polygraph monitoring. This approach represents the SOTMP's plan to transition sex offenders into the community.

***FINDING: Few TC offenders receive community-based aftercare. Interview data revealed several reasons for the lack of movement of sex offenders into community corrections. These included: community safety concerns, liability issues, the cost of treatment services, and concerns about potential media attention. In addition, few offenders meet a key criterion to enter community corrections from prison: passing a sex history polygraph examination.***

Unfortunately, few offenders actually transfer to this level of structure and service. Barriers interfere with this transition plan. For instance, many of the local boards and program directors do not accept these cases into the community corrections system.

Two programs regularly accept sex offenders. One of these programs accepts offenders recommended from either Phase I or the therapeutic community when space is available. The second program only accepts individuals from the TC; however, the program also serves some offenders who may have had sex offenses in their histories, but who were serving their sentences for other crimes.

Interviews with administrators from these the two programs told us that, while the local community corrections board may generally support the idea of transition services for sex offenders, board members are not enthusiastic about letting sex offenders back into their communities. Administrators noted that community board members' concerns regarding safety were a barrier to accepting sex offenders, and interviewees suggested educating both communities and the local boards about the potential to increase safety when this population is managed in groups. It is clear from the interview data that

*The challenge of finding appropriate community housing in general for sex offenders was mentioned by program administrators and DOC officials.*

concerns about community risk and related program liability issues revolve around the potential long-term impact if a "critical incident" involving a sex offender were to occur. One program is set in a university community, where the chancellor had expressed concerns regarding the proximity of the program to campus. The challenge of finding appropriate community housing in general for sex offenders was mentioned by program administrators and DOC officials. The cost of funding the special needs of sex offenders was also mentioned as a barrier, as well as well as media attention to sex offenses that raise community fears.



***FINDING: Although few sex offenders have been placed in community corrections from the SOTMP TC, the halfway house programs perceived important benefits to Therapeutic Community treatment.***

The two community corrections administrators whose programs accept sex offenders reported that the men who attended the TC have an understanding of treatment expectations. That is, they know what it means to engage in group therapy. These offenders are also familiar with rules and violations associated with treatment. Offenders who have participated in the therapeutic community are familiar with cognitive behavioral therapy, problematic behavior patterns and thinking errors, and relapse prevention concepts, and some have helped other sex offenders who did not participate in prison treatment understand treatment tools.<sup>134</sup>

Remarks from halfway house administrators were similar to DOC parole officers' and revealed that offenders who had participated in the therapeutic community had a better understanding of their behaviors and the cycles leading to an offense. A community corrections program director told us, "it's obvious the TC helps," referring to the emphasis the Therapeutic Community placed on criminal thinking, power and control and management issues, as well as their use of the polygraph in the treatment program. According to this information, individuals receiving treatment from the Therapeutic Community may be more prepared for supervision and treatment in the community, and this preparation may help them manage their risk.

*A community corrections program director told us, "it's obvious the TC helps."*

One interviewee noted, "the problem is they don't serve enough people or get enough people through fast enough." Referring to the SOTMP, these comments echo those made by the Department of Corrections and TC staff that expressed similar sentiments regarding the difficulties of moving inmates through the program.<sup>135</sup> The two administrators we interviewed said they were eager to receive more transition clients from the TC. However, they both mentioned that training for both security and line staff on sex offender treatment, management, and monitoring would be helpful.

To find out about the transition from prison to community, we conducted a focus group with three offenders recently released from prison to community corrections.

***FINDING: Offenders released to community corrections described the challenges of coping in an environment with less structure, impediments to obtaining jobs, and difficulties living with the general population (non-sex offenders).***

To try to understand more about the way offenders transition into the community through community corrections, we spoke with three offenders who had been released from prison into the same community corrections program. All three offenders arrived at the program at the same time, and at the time of the focus group, they had been in the

---

<sup>134</sup> All convicted sex offenders in Colorado are required to participate in treatment when serving sentences in the community. Sex offenders transitioning from prison who did not participate in any aspect of the SOTMP must begin therapy with an SOMB-approved provider upon release into the community.

<sup>135</sup> The expectation or desire for moving inmates through the program contradicts a finding presented later in this report: the longer a person spends in treatment, the greater the likelihood that he will stay arrest-free after release from prison.

program for a little over a month. When asked about the transition, all three offenders agreed that there was less structure in the community corrections program compared to the TC. The offenders described the community corrections treatment team as supportive, but perhaps not ready to fully implement a program for them. One offender told us, “seems like they went to a whole lot of work to get us here but [now] don’t know what to do with us...” This less structured environment was difficult for two offenders, who discussed reduced responsibilities compared to the TC, the lack of a job, and the absence of a gym that had been useful for “venting.” “My day started at 4 a.m. [in the TC] and I didn’t quit until 8 p.m., seven days a week.” Here I can sleep in until 10 a.m. if I want to.” The third offender described the lack of structure as a “blessing” because it was a relief from the intensity of the pace at the TC.

The offenders were not working at the time of the focus group, and described impediments to quickly securing jobs. “I ...collected phone numbers for jobs in Denver while I was in prison, so when I got here I was all ready to go but couldn’t,” reported one offender. They cannot get jobs (i.e., they are “on hold”) until they pass a maintenance polygraph. (Apparently, they were scheduled for polygraphs the following week—from our calculations, nearly six weeks after release). Sex offenders must also be accompanied to job interviews. These offenders remarked that the “Board,” presumably the Community Corrections Board, expects them to have members of their support team drive them to job interviews. However, this is difficult, if not impossible, if an offender does not have a support team member living close by. One offender remarked that the community corrections program is considering permitting contact with some senior members of the treatment program where they receive group therapy. Presumably, these senior members could assist the community corrections inmates by accompanying them to interviews. These offenders were unclear of the steps that would occur if they did not pass the polygraph. They did not know if they would be required to be accompanied to jobs they obtained.

At the time of the interviews, these offenders attended two groups per week. The treatment program offered weekend groups but, thus far, these offenders were not attending. “They are working on figuring out how we can get to those.”

Other transitional difficulties experienced by these offenders included adjusting to communicating with general population offenders, and refraining from participating in profanity and objectification of females typical of the general population.

The offenders in the focus group were in agreement that although there had been many unknowns for them in this transition, they were grateful that they had come to the community corrections program together so they could provide support and encouragement for each other. While one offender said “You get a sense of community with other brothers here. We brought the TC with us,” the other two offenders nodded their heads in agreement. For them, this support is critical. “There is a lot of negative stuff that goes on here...Don’t know how the guys that came before us one at a time dealt with it; that’s probably why they failed.”

***FINDING: For these offenders, release to community corrections was a better option than discharging directly into the community.***

As one offender remarked, “...this is the next logical step.” This offender’s support team was out of state, but he noted “...I have a lot of support here—case managers,

members of the board, brothers.” Another offender remarked that while he enjoyed the less structured atmosphere of community corrections compared to the TC, “There wouldn’t have been enough structure if I would have come out on my own.” Another inmate remarked that he was unsure if discharging to community corrections would be easier or more difficult than discharging on his own. But he acknowledged, “If I got out on my own, I would have gone to work right away and then become addicted to my work. I wouldn’t have been able to find the balance because of my addictive personality. Community corrections let me find a balance.”

Another offender noted that financial concerns would have been a stressor had he been released directly into the community. “...[at DOC] they do everything; I was spoiled... if I came out on my own, I would need financial stability...this is a good transition....”

***FINDING: Each of the three offenders we spoke with described specific tools and skills they learned at the TC that they currently used to help with their transition from prison.***

These tools and skills included use of “switch statements” (i.e., replacing negative or distorted thoughts with positive ones), personal change contracts, victim empathy, holding self and others accountable, rational self-analysis (a technique used at the TC to challenge cognitive distortions, self-awareness (used to challenge motives and attitudes behind thoughts), the community philosophy of helping others and following rules, setting boundaries, and awareness of their cycles of abuse. “All that practice in the [TC] community makes me safer here and it is going to be a constant process. I know I am dangerous and I need to keep people safe,” noted one offender.

## OUTCOME FINDINGS: OFFICIALLY RECORDED RECIDIVISM

***Question 2. Are outcomes for sex offenders who receive SOTMP services better than the outcomes of sex offenders who do not receive these services?***

To answer this question, we undertook two separate analyses. The first analysis focused on the group of offenders released to parole to determine the proportion of the group that was revoked back to prison.<sup>136</sup> The second analysis looks at the rearrest rate of the group of offenders who were discharged directly from prison or parole. The parole group for this analysis includes those who successfully completed their parole period in the first analysis. It also includes offenders who failed in the first analysis described above, were revoked to prison, and were paroled again to the community later. Those who served out the remainder of their sentence in prison and eventually discharged to the community were included in the group directly discharged from prison, as well as those who were never paroled and so were released directly from prison.

In this section, we first describe the sample and the differences in the treated and the non-treated group, and then we present the findings from the recidivism study.

### A. Study Sample Characteristics

Table 7 shows that the final study sample consisted of 3338 discharged inmates. The comparison group was the largest, with 2465 former inmates who were identified as sex offenders but who did not participate in the SOTMP. Five hundred and forty-eight (548) inmates participated in Phase 1 only and 325 participated in both Phase 1 and Phase 2. See Section 3 (Research Questions, Data Collection, and Methods) of this report for a detailed discussion of the sample groups.

**Table 7:**

**Study Sample Groups**

|                     | Count | Percent |
|---------------------|-------|---------|
| <b>No Treatment</b> | 2465  | 73.8%   |
| <b>Phase 1</b>      | 548   | 16.4%   |
| <b>Phase 2</b>      | 325   | 9.7%    |
| <b>Total</b>        | 3338  | 100.0%  |

#### (1) Demographics

Most of the participants in either Phase 1 or Phase 2 were white, as shown in Table 8 on the next page. In fact, it appears that relatively few people of color participated in the SOTMP. Participants in treatment were slightly more often divorced and slightly more

---

<sup>136</sup>Those under parole supervision clearly have a different release situation than those who are discharged without parole, so parolees were analyzed separately.

often married than the non-treatment group, a finding likely related to differences in the average age of offenders in the three groups. Approximately two-thirds of each group was single, including those divorced or widowed (see Table 9). Sample selection criteria excluded females because women do not participate in TC treatment at the Arrowhead facility.

As shown in Table 10 on the following page, the three groups varied significantly in age at release, with Phase 2 participants being the oldest at 38.5 years. Those in Phase 1 were slightly younger at 37.1, and those with no treatment were the youngest at 36 years. Phase 2 clients had the most dependents, on average, while Phase 1 clients had the fewest, though these differences were not statistically significant.

**Table 8:**

**Ethnicity**

|              |              | Treatment Group |         |         | Total  |
|--------------|--------------|-----------------|---------|---------|--------|
|              |              | No Treatment    | Phase 1 | Phase 2 |        |
| <b>Other</b> | <b>Count</b> | 76              | 14      | 6       | 96     |
|              | <b>%</b>     | 3.1%            | 2.6%    | 1.8%    | 2.9%   |
| <b>Black</b> | <b>Count</b> | 477             | 100     | 59      | 636    |
|              | <b>%</b>     | 19.4%           | 18.4%   | 18.2%   | 19.1%  |
| <b>Hisp</b>  | <b>Count</b> | 721             | 114     | 52      | 887    |
|              | <b>%</b>     | 29.3%           | 21.0%   | 16.0%   | 26.6%  |
| <b>White</b> | <b>Count</b> | 1186            | 316     | 208     | 1710   |
|              | <b>%</b>     | 48.2%           | 58.1%   | 64.0%   | 51.4%  |
| <b>Total</b> | <b>Count</b> | 2460            | 544     | 325     | 3329   |
|              | <b>%</b>     | 100.0%          | 100.0%  | 100.0%  | 100.0% |

Significant at  $p < .001$

**Table 9:**

**Marital Status**

|                      |              | Treatment Group |         |         | Total  |
|----------------------|--------------|-----------------|---------|---------|--------|
|                      |              | No Tx           | Phase 1 | Phase 2 |        |
| <b>Married</b>       | <b>Count</b> | 778             | 186     | 108     | 1072   |
|                      | <b>%</b>     | 32.0%           | 34.9%   | 34.2%   | 32.7%  |
| <b>Divorced</b>      | <b>Count</b> | 739             | 169     | 115     | 1023   |
|                      | <b>%</b>     | 30.4%           | 31.7%   | 36.4%   | 31.2%  |
| <b>Never married</b> | <b>Count</b> | 913             | 178     | 93      | 1184   |
|                      | <b>%</b>     | 37.6%           | 33.4%   | 29.4%   | 36.1%  |
| <b>Total</b>         | <b>Count</b> | 2430            | 533     | 316     | 3279   |
|                      | <b>%</b>     | 100.0%          | 100.0%  | 100.0%  | 100.0% |

Differences not statistically significant

**Table 10:****Study Group Comparison: Age and Dependents**

|                     |             | Age at Release<br>*** | Number of Dependents<br>~ |
|---------------------|-------------|-----------------------|---------------------------|
| <b>No Treatment</b> | <b>Mean</b> | 36.0771               | 1.4256                    |
|                     | <b>N</b>    | 2256                  | 2223                      |
|                     | <b>S.D.</b> | 10.65718              | 1.78546                   |
| <b>Phase 1</b>      | <b>Mean</b> | 37.1153               | 1.3862                    |
|                     | <b>N</b>    | 503                   | 492                       |
|                     | <b>S.D.</b> | 9.78487               | 1.62003                   |
| <b>Phase 2</b>      | <b>Mean</b> | 38.4507               | 1.5180                    |
|                     | <b>N</b>    | 284                   | 278                       |
|                     | <b>S.D.</b> | 8.66215               | 1.73872                   |
| <b>Total</b>        | <b>Mean</b> | 36.4703               | 1.4277                    |
|                     | <b>N</b>    | 3043                  | 2993                      |
|                     | <b>S.D.</b> | 10.36928              | 1.75473                   |

\*\*\* Significant at  $p < .001$

~ Differences not statistically significant

**(2) Criminal History/Incarcerations**

The groups appear to vary in terms of criminal history, but it is unclear which group might have the most serious offenders. As shown in Table 11, the no treatment group had a record of significantly more prior felonies. However, the sex offenders participating in the SOTMP were incarcerated for significantly longer periods of time, most likely due to the fact that they were more frequently serving time for a sexual assault (Table 12). While the no treatment group averaged significantly more prior incarcerations (Table 11), equivalent proportions across the three groups had no prior incarcerations (Table 13).

**Table 11:****Average Prior Felonies, Prior Incarcerations and Length of Current Incarceration**

|                     |             | Number of Prior Felonies<br>*** | Length (days) of current incarceration<br>*** | Number of Previous Incarcerations<br>*** |
|---------------------|-------------|---------------------------------|---|--|
| <b>No Treatment</b> | <b>Mean</b> | 1.3481                          | 1267.9363                                     | .3765                                    |
|                     | <b>N</b>    | 2465                            | 2464  | 2465                                     |
|                     | <b>S.D.</b> | 1.96947                         | 1112.50124                                    | .65485                                   |
| <b>Phase 1</b>      | <b>Mean</b> | .8942                           | 1892.8376                                     | .3248                                    |
|                     | <b>N</b>    | 548                             | 548   | 548                                      |
|                     | <b>S.D.</b> | 1.55805                         | 1081.47099                                    | .58027                                   |
| <b>Phase 2</b>      | <b>Mean</b> | .7169                           | 2241.8769                                     | .2431                                    |
|                     | <b>N</b>    | 325                             | 325   | 325                                      |
|                     | <b>S.D.</b> | 1.27167                         | 1179.34150                                    | .53228                                   |
| <b>Total</b>        | <b>Mean</b> | 1.2121                          | 1465.4120                                     | .3550                                    |
|                     | <b>N</b>    | 3338                            | 3337  | 3338                                     |
|                     | <b>S.D.</b> | 1.86363                         | 1165.41044                                    | .63329                                   |

\*\*\* Significant at  $p < .001$

**Table 12:**

**Sex Crime Conviction Charges (this incarceration)**

|                          |              | Treatment Group |         |         | Total |
|--------------------------|--------------|-----------------|---------|---------|-------|
|                          |              | No Treatment    | Phase 1 | Phase 2 |       |
| <b>Rape</b>              | <b>Count</b> | 359             | 145     | 110     | 614   |
|                          | <b>%</b>     | 14.6%           | 26.5%   | 33.8%   | 18.4% |
| <b>Sex Assault</b>       | <b>Count</b> | 1002            | 440     | 288     | 1730  |
|                          | <b>%</b>     | 40.6%           | 80.3%   | 88.6%   | 51.8% |
| <b>Child Molestation</b> | <b>Count</b> | 607             | 280     | 174     | 1061  |
|                          | <b>%</b>     | 24.6%           | 51.1%   | 53.5%   | 31.8% |
| <b>Incest</b>            | <b>Count</b> | 57              | 27      | 16      | 100   |
|                          | <b>%</b>     | 2.3%            | 4.9%    | 4.9%    | 3.0%  |

Note: Offenders could be convicted of more than one of these crimes. Therefore, the total number reported in this table exceeds the sample size.

**Table 13:**

**Prior Incarcerations**

|                  |              | Treatment Group |         |         | Total  |
|------------------|--------------|-----------------|---------|---------|--------|
|                  |              | No Treatment    | Phase 1 | Phase 2 |        |
| <b>None</b>      | <b>Count</b> | 1938            | 428     | 242     | 2608   |
|                  | <b>%</b>     | 85.9%           | 85.1%   | 85.2%   | 85.7%  |
| <b>1+ priors</b> | <b>Count</b> | 318             | 75      | 42      | 435    |
|                  | <b>%</b>     | 14.1%           | 14.9%   | 14.8%   | 14.3%  |
| <b>Total</b>     | <b>Count</b> | 2256            | 503     | 284     | 3043   |
|                  | <b>%</b>     | 100.0%          | 100.0%  | 100.0%  | 100.0% |

Inmates in Phase 1 more often discharged their sentences from prison than from parole, meaning that they were less likely to undergo parole supervision during this study's at-risk period (see Table 14). This finding is unlikely to be related to parole board decisions but rather reflects the trend of waiving or refusing parole, an inmate behavior that escalated during the late 1980s and early 1990s.<sup>137</sup> It is important to remember that findings pertaining to parole release reflect occurrences between April 1, 1993 and March 30, 2002. Until legislation was passed in 1993 mandating parole supervision for individuals convicted after July 1 of that year, offenders were allowed to refuse parole and serve out their entire sentence in prison. This means many offenders self-selected out of parole and discharged their sentence in prison. The extent to which this biases the release cohorts is unknown.

<sup>137</sup>Current parole board members are extremely reluctant to release sex offenders who refused to participate in treatment.

**Table 14:****Released to Parole**

|              |              | Treatment Group |         |         | Total  |
|--------------|--------------|-----------------|---------|---------|--------|
|              |              | No Treatment    | Phase 1 | Phase 2 |        |
| <b>No</b>    | <b>Count</b> | 1691            | 413     | 215     | 2319   |
|              | <b>%</b>     | 68.6%           | 75.4%   | 66.2%   | 69.5%  |
| <b>Yes</b>   | <b>Count</b> | 774             | 135     | 110     | 1019   |
|              | <b>%</b>     | 31.4%           | 24.6%   | 33.8%   | 30.5%  |
| <b>Total</b> | <b>Count</b> | 2465            | 548     | 325     | 3338   |
|              | <b>%</b>     | 100.0%          | 100.0%  | 100.0%  | 100.0% |

Significant at p&lt;.01

The majority of inmates participating in the SOTMP were assigned a score of S5 (meaning that they had a current or past conviction for a sex crime) on the Sexual Violence Code, with 94.2 percent of the Phase 2 group and 89.1 percent of the Phase 1 group so designated (see Table 15). However, of the 2147 S5 inmates in the study, only 37 percent participated in either treatment phase. Very small percentages of S4 (offenders with an official record history of sex crimes but not necessarily convicted) inmates participated in Phase 1 (5.0 percent) and even fewer participated in Phase 2 (1.8 percent). Only 3.2 percent of the sample was designated S3 (offenders exhibiting sexually deviant behavior or sexually assaulting inmates or staff while in prison), and only six of these participated in Phase 1 and none in Phase 2.<sup>138</sup> This classification method provides an important description of the offenders in the study. Refer to Appendix Q for complete information about the conviction crimes by treatment group.

**Table 15:****Sexual Violence Code**

|              |              | Treatment Group |         |         | Total  |
|--------------|--------------|-----------------|---------|---------|--------|
|              |              | No Tx           | Phase 1 | Phase 2 |        |
| <b>S3</b>    | <b>Count</b> | 100             | 6       |         | 106    |
|              | <b>%</b>     | 4.1%            | 1.1%    |         | 3.2%   |
| <b>S4</b>    | <b>Count</b> | 1012            | 54      | 19      | 1085   |
|              | <b>%</b>     | 41.1%           | 9.9%    | 5.8%    | 32.5%  |
| <b>S5</b>    | <b>Count</b> | 1353            | 488     | 306     | 2147   |
|              | <b>%</b>     | 54.9%           | 89.1%   | 94.2%   | 64.3%  |
| <b>Total</b> | <b>Count</b> | 2465            | 548     | 325     | 3338   |
|              | <b>%</b>     | 100.0%          | 100.0%  | 100.0%  | 100.0% |

Significant at p&lt;.001

<sup>138</sup> A separate analysis of outcome by S-Code found that S-3 offenders were significantly more likely to be rearrested for a violent crime compared to S4s and S5s. In addition, of those who were rearrested, S3s were rearrested sooner. (Findings presented by ORS staff at the annual conference of the Bureau of Justice Statistics and the Justice Research and Statistics Association, Boston, Massachusetts, October 3-4, 2002.); also presented as: Poster Presentation - Is Sex Offending Behavior in Prison Indicative of Risk for Reoffense? The Association for the Treatment of Sexual Abusers 21st Annual Research and Treatment Conference Co-presenters - Sean Ahlmeyer, Researcher, Colorado Department of Corrections and Linda Harrison, Researcher, Colorado Division of Criminal Justice (10/4/02).



## B. Results

### (1) Does Treatment Influence Success on Parole?

To determine the proportion of parolees who were revoked and the proportion that successfully completed parole, we examined the first parole period for all inmates who were placed on parole, either immediately following participation in treatment or after the implementation of the therapeutic community (if no treatment was received). As discussed above, offenders commonly waived parole during the at-risk period, creating an unavoidable and unknown selection bias in the release cohorts.

***FINDING: Participation in treatment is significantly associated with success on parole.***

As shown in Table 16, participation in treatment appears to be significantly related to successful parole completion. Just under half (47.7 percent) of those parolees who did not participate in the SOTMP treatment were revoked and returned to prison, compared to 30 percent of those who participated only in Phase 1. Those who participated in Phase 2 demonstrated even greater success, with only 15.8 percent returning to prison on a revocation. Future analysis to determine what factors contributed to parole success would be valuable; data were not available to pursue this question in the current study.

*Just under half (47.7 percent) of those parolees who did not participate in the SOTMP treatment were revoked and returned to prison, compared to 30 percent of those who participated only in Phase 1. Those who participated in Phase 2 demonstrated even greater success, with only 15.8 percent returning to prison on a revocation.*

**Table 16:**

**Parole Outcomes by Study Group**

|                 |              |           |            | Total  |
|-----------------|--------------|-----------|------------|--------|
|                 |              | Completed | Revocation |        |
| <b>No SO tx</b> | <b>Count</b> | 685       | 625        | 1310   |
|                 | <b>%</b>     | 52.3%     | 47.7%      | 100.0% |
| <b>Phase 1</b>  | <b>Count</b> | 112       | 48         | 160    |
|                 | <b>%</b>     | 70.0%     | 30.0%      | 100.0% |
| <b>Phase 2</b>  | <b>Count</b> | 97        | 18         | 115    |
|                 | <b>%</b>     | 84.3%     | 15.7%      | 100.0% |
| <b>Total</b>    | <b>Count</b> | 894       | 691        | 1585   |
|                 | <b>%</b>     | 56.4%     | 43.6%      | 100.0% |

Significant at  $p < .001$

### (2) Does Treatment Influence Overall Recidivism?

Recidivism was measured by new arrests, court filings and returns to prison. Tables 17 and 18 depict success rates (defined as *no new event*) at one, two and three years post-discharge. Only those discharges with a minimum of one year at risk were included in the one-year analysis. Likewise, only those with two and three years at risk were included in the two-year and three-year analyses. Therefore, the number of eligible

offenders decreases as the number of elapsed years increases, as can be seen in the 'Total N' column in each of the following tables.

Findings for offenders released directly from prison with no supervision are presented in Table 17. Since offenders released to supervision are under greater scrutiny than offenders directly discharged from prison with no supervision, the findings for those released to parole are presented separately in Table 18 on page 116. New arrests, filings and incarcerations for violent crimes and for sex crimes are presented separately, and are also included in the 'overall crimes' category.

**Table 17:**

**Outcome Information On Sex Offenders Discharged Directly from Prison  
Between April 1, 1993 and July 30, 2002**

| Overall Crimes        |                 | No new arrests | P   | No new court filings | P   | No New Incarc. | P   | Total N |
|-----------------------|-----------------|----------------|-----|----------------------|-----|----------------|-----|---------|
| <b>1 year out</b>     | <b>No Tx</b>    | 66.2%          |     | 83.0%                |     | 91.3%          |     | 1497    |
|                       | <b>Phase I</b>  | 75.8%          | *** | 87.0%                | *** | 97.8%          |     | 368     |
|                       | <b>Phase II</b> | 84.0%          |     | 92.6%                |     | 98.3%          |     | 175     |
| <b>2 years out</b>    | <b>No Tx</b>    | 51.6%          |     | 72.0%                |     | 86.7%          |     | 1264    |
|                       | <b>Phase I</b>  | 64.5%          | *** | 78.8%                | **  | 92.1%          | *** | 330     |
|                       | <b>Phase II</b> | 69.3%          |     | 82.9%                |     | 95.7%          |     | 140     |
| <b>3 years out</b>    | <b>No Tx</b>    | 44.7%          |     | 64.8%                |     | 79.2%          |     | 1098    |
|                       | <b>Phase I</b>  | 57.2%          | *** | 72.4%                | *** | 88.2%          | *** | 297     |
|                       | <b>Phase II</b> | 65.5%          |     | 79.8%                |     | 89.9%          |     | 119     |
| <b>Violent Crimes</b> |                 |                |     |                      |     |                |     |         |
| <b>1 year out</b>     | <b>No Tx</b>    | 85.7%          |     | 92.2%                |     | 98.8%          |     | 1497    |
|                       | <b>Phase I</b>  | 92.1%          | *** | 95.1%                | *   | 99.7%          |     | 368     |
|                       | <b>Phase II</b> | 93.1%          |     | 96.0%                |     | 100%           |     | 175     |
| <b>2 years out</b>    | <b>No Tx</b>    | 78.3%          |     | 87.2%                |     | 96.0%          |     | 1264    |
|                       | <b>Phase I</b>  | 86.4%          |     | 89.7%                |     | 98.5%          |     | 330     |
|                       | <b>Phase II</b> | 83.6%          |     | 91.4%                |     | 100%           |     | 140     |
| <b>3 years out</b>    | <b>No Tx</b>    | 73.8%          |     | 83.0%                |     | 93.3%          |     | 1098    |
|                       | <b>Phase I</b>  | 83.2%          | **  | 87.2%                |     | 97.0%          |     | 297     |
|                       | <b>Phase II</b> | 78.2%          |     | 86.6%                |     | 97.5%          |     | 119     |
| <b>Sex Crimes</b>     |                 |                |     |                      |     |                |     |         |
| <b>1 year out</b>     | <b>No Tx</b>    | 96.8%          |     | 97.9%                |     | 98.8%          |     | 1497    |
|                       | <b>Phase I</b>  | 96.2%          |     | 95.1%                | **  | 98.9%          |     | 368     |
|                       | <b>Phase II</b> | 97.7%          |     | 96.0%                |     | 99.4%          |     | 175     |
| <b>2 years out</b>    | <b>No Tx</b>    | 94.4%          |     | 96.0%                |     | 97.7%          |     | 1264    |
|                       | <b>Phase I</b>  | 93.6%          |     | 91.8%                | *** | 97.3%          |     | 330     |
|                       | <b>Phase II</b> | 93.6%          |     | 91.4%                |     | 97.9%          |     | 140     |
| <b>3 years out</b>    | <b>No Tx</b>    | 92.6%          |     | 94.6%                |     | 96.2%          |     | 1098    |
|                       | <b>Phase I</b>  | 92.6%          |     | 90.6%                | *   | 97.0%          |     | 297     |
|                       | <b>Phase II</b> | 93.3%          |     | 91.6%                |     | 95.0%          |     | 119     |

\* P<.05, \*\* P<.01, \*\*\*P<.001

Table 17 shows that the proportion of untreated former inmates with *no new arrests* in their first year is 66.2 percent. This percentage increases to 75.8 percent for Phase 1 participants, and to 84.0 percent for Phase 2 participants. These differences are significant and meaningful in terms of public safety. While these numbers decrease as offenders spend more time in the community (51.6 percent for the no-treatment group, 64.5 percent for the Phase 1 group, and 69.3 percent for the Phase 2 group after two years) the value of treatment participation remains evident. After three years in the community, the success rates for the no treatment group falls to 44.7 percent, compared to 57.2 percent and 65.5 percent for the Phase 1 and Phase 2 groups respectively. All of these differences are statistically significant, and were also found with new filings and with new incarcerations.

*Proportion of untreated former inmates with no new arrests in their first year is 66.2 percent. This percentage increases to 75.8 percent for Phase 1 participants, and to 84.0 percent for Phase 2 participants. These differences are significant and meaningful in terms of public safety.*

We found few new violent crimes and new sex crimes as measured by arrest, filing and incarceration data. The numbers were too small to confidently apply statistical tests since the power to detect differences is reduced when the sample size is small.<sup>139</sup>

***FINDING: The long term outcome of offenders who received parole supervision was significantly better than the group that was discharged from prison without parole.***

The group of offenders who successfully completed parole was followed from the point of parole completion. As reflected in Table 18, this group experienced greater success than those discharged directly from prison (Table 17) without parole. Few parolees experienced these outcome events, and consequently the power to detect group differences is so small that the outcomes reported rarely reached statistical significance.

However, the proportions of parolees not receiving any new overall arrests do show a significant trend associating treatment with success. At one year, 76.9 percent of the no treatment group was arrest-free, compared to 84.4 percent of the former Phase 1 inmates and 93.6 percent of the former Phase 2 inmates. At two years, these percentages drop to 65.6 percent for those not treated and remain relatively high for the treatment groups: 73.3 for Phase 1, and 83.3 for Phase 2. At three years, overall success rates decline again to 58.0 percent for no treatment, 59.5 percent for Phase 1, but remain relatively high at 79.0 percent for Phase 2 participants.

*At one year, 76.9 percent of the no treatment group was arrest-free, compared to 84.4 percent of the former Phase 1 inmates and 93.6 percent of the former Phase 2 inmates.*

<sup>139</sup> See Appendix R for failure rates and associated sample sizes.

Table 18:

**Outcome Information On Sex Offenders Discharged from Parole  
Between April 1, 1993 and July 30, 2002**

| Overall Crimes        |          | No new arrests | P   | No new court filings | P | No New Incarc. | P | Total N |
|-----------------------|----------|----------------|-----|----------------------|---|----------------|---|---------|
| 1 year out            | No Tx    | 76.9%          | *** | 94.2%                |   | 99.7%          |   | 759     |
|                       | Phase I  | 84.4%          |     | 95.6%                |   | 100%           |   | 135     |
|                       | Phase II | 93.6%          |     | 99.1%                |   | 100%           |   | 109     |
| 2 years out           | No Tx    | 65.6%          | **  | 86.0%                |   | 97.4%          |   | 655     |
|                       | Phase I  | 73.3%          |     | 84.8%                |   | 97.1%          |   | 105     |
|                       | Phase II | 83.3%          |     | 93.6%                |   | 100%           |   | 78      |
| 3 years out           | No Tx    | 58.0%          | **  | 80.3%                |   | 93.9%          |   | 543     |
|                       | Phase I  | 59.5%          |     | 73.8%                |   | 91.7%          |   | 84      |
|                       | Phase II | 79.0%          |     | 88.7%                |   | 98.4%          |   | 62      |
| <b>Violent Crimes</b> |          |                |     |                      |   |                |   |         |
| 1 year out            | No Tx    | 91.6%          |     | 97.9%                |   | 100%           |   | 759     |
|                       | Phase I  | 97.0%          |     | 97.8%                |   | 100%           |   | 135     |
|                       | Phase II | 99.1%          |     | 100%                 |   | 100%           |   | 109     |
| 2 years out           | No Tx    | 86.9%          |     | 94.4%                |   | 99.7%          |   | 655     |
|                       | Phase I  | 91.4%          |     | 94.3%                |   | 99.0%          |   | 105     |
|                       | Phase II | 97.4%          |     | 97.4%                |   | 100%           |   | 78      |
| 3 years out           | No Tx    | 81.6%          |     | 91.2%                |   | 99.3%          |   | 543     |
|                       | Phase I  | 86.9%          |     | 90.5%                |   | 97.6%          |   | 84      |
|                       | Phase II | 90.3%          |     | 93.5%                |   | 98.4%          |   | 62      |
| <b>Sex Crimes</b>     |          |                |     |                      |   |                |   |         |
| 1 year out            | No Tx    | 99.5%          |     | 98.9%                |   | 100%           |   | 759     |
|                       | Phase I  | 99.3%          |     | 100%                 |   | 100%           |   | 135     |
|                       | Phase II | 98.2%          |     | 100%                 |   | 100%           |   | 109     |
| 2 years out           | No Tx    | 99.4%          |     | 97.6%                |   | 100%           |   | 655     |
|                       | Phase I  | 96.2%          |     | 96.2%                |   | 98.1%          |   | 105     |
|                       | Phase II | 97.4%          |     | 96.2%                |   | 100%           |   | 78      |
| 3 years out           | No Tx    | 99.1%          |     | 97.6%                |   | 99.4%          |   | 543     |
|                       | Phase I  | 90.5%          |     | 91.7%                |   | 96.4%          |   | 84      |
|                       | Phase II | 96.8%          |     | 95.2%                |   | 98.4%          |   | 62      |

\* P<.05, \*\* P<.01, \*\*\*P<.001

### (3) Does Treatment Influence Time to New Arrests?

The above discussions simply address whether a new arrest or other event occurred within a specific time frame. This technique requires that the analysis groups have equal at-risk periods, that is, an equal number of months to incur a new arrest (12 months, 24 months, and 36 months). This method will ultimately underestimate the rate of re-arrest since some individuals without the requisite time-at-risk eventually re-offended, or new offenses occurred after the allotted time frame. However, this is the most traditional method of reporting case outcomes.

Survival analysis was used to compensate for the limitations to the traditional method of reporting recidivism.<sup>140</sup> This is a statistical technique commonly used in medical and biological research, but its use has expanded in recent years to the fields of engineering, astronomy, economic and social sciences. Kaplan-Meier is one method of survival analysis used here to assess whether treatment impacted the length of time to a failure event.<sup>141,142</sup>

***FINDING: Offenders who received treatment remained arrest-free longer. They also continued over time to be at lower risk of rearrest compared to those with no treatment. Additionally, those participated in Phase 2 treatment are at less risk of rearrest than are those who received only Phase 1 treatment.***

For the purposes of this analysis, time to new arrest was used as the outcome measure. Further, the paroled and the discharged groups were combined to eventually examine and control for the impact of parole supervision on rearrest, a topic we discuss later in this section. The results of the analysis are presented in Figure 3 on the next page. The lines represent the proportion of former inmates who have succeeded (in terms of remaining arrest-free) over time by treatment groups. The differences in the rates of failure between the Phase 2, Phase 1 and no treatment groups are significant. That is, Phase 1 and Phase 2 groups 'survive' for longer periods without experiencing a new arrest.

---

<sup>140</sup> Survival analyses are useful in situations when the distribution of time between two events (such as release from prison and rearrest) is examined and the event (rearrest) does not occur for all cases. The technique also allows for varying time-at-risk periods, meaning that all data regardless of the variation in time-at-risk can be used in the analysis.

<sup>141</sup> The Kaplan-Meier procedure uses a method of calculating life tables that estimates the survival or hazard function at the time of each event. The Kaplan-Meier model is based on estimating conditional probabilities at each time point when an event occurs and taking the product limit of those probabilities to estimate the survival rate at each point in time.

<sup>142</sup> Lee, Elisa T. 1992. *Statistical Methods for Survival Data Analysis*. 2nd ed. New York: John Wiley & Sons.

Figure 3:

The proportion of cases not rearrested for a new crime during the study period, by treatment/no treatment groups

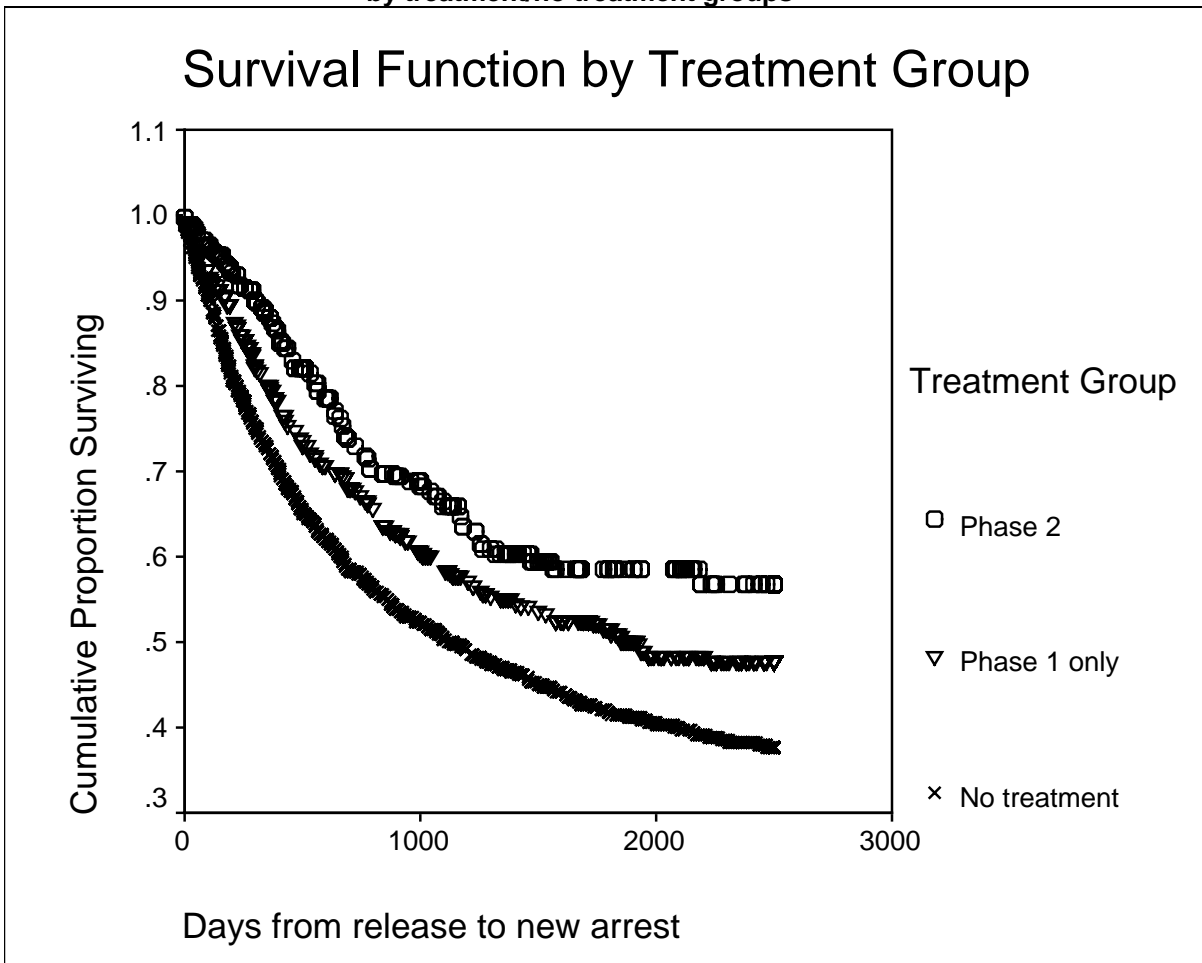

Significant at  $p < .001$

The average length of time to a new arrest for the no treatment group was substantially shorter than the Phase 1 group, and the time to new arrest for the Phase 1 group was shorter than the average time for the TC group.

*These results are encouraging, and the separation among the groups continued for a minimum of almost eight years, the maximum amount of at risk time available. This suggests that the SOTMP likely provides an important contribution to public safety.*

These differences, which are summarized in Table 19, display a remarkable separation in the outcomes for the three groups. These results are encouraging, and the separation among the groups continued for a minimum of almost eight years, the maximum amount of at risk time available. This suggests that the SOTMP likely provides an important contribution to public safety.

**Table 19:**

**Time To New Arrest**

|   | No Treatment | Phase 1 | Phase 2   | Overall |
|---|--------------|---------|-----------|---------|
| <b>Mean Survival time</b>                             | 1312.34      | 1531.44 | 1715.32   | 1385.90 |
| <b>Standard Error (SE)</b>                            | 23.04        | 47.73   | 63.69     | 19.87   |
| <b>Median Survival time</b>                           | 1069.00      | 1849.00 | >2179.00* | 1241.00 |
| <b>Mean Survival, failures only</b>                   | 506.43       | 548.61  | 575.44    | 516.91  |
| <b>SE Mean Survival, failures only</b>                | 15.40        | 32.67   | 48.00     | 13.43   |
| <b>Total N (N entering)</b>                           | 2465         | 548     | 325       | 3338    |
| <b>N New Arrests (N events)</b>                       | 1203         | 224     | 95        | 1522    |
| <b>Percent With No New Arrests (Percent Censored)</b> | 51.20%       | 59.12%  | 70.77%    | 54.40%  |

\*A median could not be calculated as the minimum cumulative survival of the Phase 2 group fell only to .5662.

**(4) What Additional Factors Influence Outcomes in Terms of New Arrests?**

The differences reported above between the Phase 1 treatment, TC treatment and the non-treatment groups beg the question of how these factors influence recidivism. Additional analyses of the new arrests at one year that revealed a variety of offender-related factors in addition to treatment participation were significantly associated with recidivism.

*Additional analyses of the new arrests at one year that revealed a variety of offender-related factors in addition to treatment participation were significantly associated with recidivism.*

Offender characteristics examined depended on data availability in DOC's automated data system. The system has expanded to capture important risk and treatment information, but this information is collected at intake and is unavailable on inmates who entered prison before new information was added to the assessment process. Few cases were missing data on the following characteristics, were available for examination:

- Client age
- Highest Grade Completed
- IQ Score
- Race/Ethnicity
- Number of Dependents
- Marital Status
- Number of Prior Felony Convictions
- Sexual Violence Score
- Time Incarcerated
- Prior Incarcerations
- Release type (parole/discharge)

**FINDING: Offenders who were rearrested tended to be younger on average, more likely to have never been married, and were more often non-Anglo. Severity of criminal history was directly correlated with failure.**

Demographic characteristics that were found to be significantly associated with new arrest include offender age, ethnicity and marital status (see Tables 20-22). Educational level, IQ scores and number of dependents proved to have no association with outcome.

**Table 20:**

**Select Demographics by New Arrest Within First Year of Release**

|                       |             | Age at discharge<br>*** | Highest Grade Claimed<br>~ | Number of Dependents<br>~ | IQ Score<br>~ |
|-----------------------|-------------|-------------------------|----------------------------|---------------------------|---------------|
| <b>No New Arrests</b> | <b>Mean</b> | 33.2661                 | 10.756                     | 1.4183                    | 102.8795      |
|                       | <b>N</b>    | 2285                    | 1198                       | 2245                      | 797           |
|                       | <b>S.D.</b> | 10.42067                | 2.1511                     | 1.74388                   | 39.17940      |
| <b>New Arrests</b>    | <b>Mean</b> | 29.2493                 | 10.531                     | 1.4559                    | 100.6546      |
|                       | <b>N</b>    | 758                     | 535                        | 748                       | 414           |
|                       | <b>S.D.</b> | 8.85684                 | 1.8998                     | 1.78779                   | 16.90836      |
| <b>Total</b>          | <b>Mean</b> | 32.2655                 | 10.687                     | 1.4277                    | 102.1189      |
|                       | <b>N</b>    | 3043                    | 1733                       | 2993                      | 1211          |
|                       | <b>S.D.</b> | 10.20154                | 2.0788                     | 1.75473                   | 33.29437      |

\*\*\* Significant at p<.001

~ Differences not statistically significant

**Table 21:**

**Race/Ethnicity**

|              |              | Recidivism Status |             | Total  |
|--------------|--------------|-------------------|-------------|--------|
|              |              | No New Arrests    | New Arrests |        |
| <b>Other</b> | <b>Count</b> | 64                | 23          | 87     |
|              | <b>%</b>     | 73.6%             | 26.4%       | 100.0% |
| <b>Black</b> | <b>Count</b> | 366               | 223         | 589    |
|              | <b>%</b>     | 62.1%             | 37.9%       | 100.0% |
| <b>Hisp</b>  | <b>Count</b> | 577               | 234         | 811    |
|              | <b>%</b>     | 71.1%             | 28.9%       | 100.0% |
| <b>White</b> | <b>Count</b> | 1272              | 275         | 1547   |
|              | <b>%</b>     | 82.2%             | 17.8%       | 100.0% |
| <b>Total</b> | <b>Count</b> | 2279              | 755         | 3034   |
|              | <b>%</b>     | 75.1%             | 24.9%       | 100.0% |

Significant at P<.001



**Table 22:**

**Marital Status**

|                      |              | Recidivism Status |             | Total  |
|----------------------|--------------|-------------------|-------------|--------|
|                      |              | No New Arrests    | New Arrests |        |
| <b>Married</b>       | <b>Count</b> | 748               | 240         | 988    |
|                      | <b>%</b>     | 75.7%             | 24.3%       | 100.0% |
| <b>Divorced</b>      | <b>Count</b> | 724               | 200         | 924    |
|                      | <b>%</b>     | 78.4%             | 21.6%       | 100.0% |
| <b>Never Married</b> | <b>Count</b> | 771               | 304         | 1075   |
|                      | <b>%</b>     | 71.7%             | 28.3%       | 100.0% |
| <b>Total</b>         | <b>Count</b> | 2243              | 744         | 2987   |
|                      | <b>%</b>     | 75.1%             | 24.9%       | 100.0% |

Significant at p<.01

Not surprisingly, those with more severe criminal histories fared worse in this analysis. Tables 23 and 24 show that the average number of prior felony convictions was significantly higher for those who incurred new arrests compared with those who remained arrest-free in the first year. The duration of the current sentence was not related to rearrest outcome. Table 24 reflects that rearrested offenders were significantly more likely to have a record of previous incarcerations compared to those who remained arrest-free. In terms of the sexual violence code (S-code), those who were assigned S4 or S3 had a greater incidence of recidivism than did those assigned S-5 (see Table 25), but these offenders were also less likely to participate in treatment. Finally, Table 26 demonstrates that offenders released directly from prison to the community were more likely to be rearrested compared to those released to parole supervision.

*Rearrested offenders were significantly more likely to have a record of previous incarcerations compared to those who remained arrest-free.*

*Offenders released directly from prison to the community were more likely to be rearrested compared to those released to parole supervision.*

**Table 23:**

**Criminal History by New Arrest Within First Year of Release**

|                       |             | <b>Number of<br/>Prior<br/>Felonies</b><br>*** | <b>Days<br/>Incarcerated<br/>(Most recent<br/>incarceration)</b><br>~ |
|-----------------------|-------------|--|---|
| <b>No New Arrests</b> | <b>Mean</b> | 1.0153   | 1445.8940   |
|                       | <b>N</b>    | 2285   | 2284  |
|                       | <b>S.D.</b> | 1.72679  | 1145.56636  |
| <b>New Arrests</b>    | <b>Mean</b> | 1.9736   | 1418.2401   |
|                       | <b>N</b>    | 758  | 758   |
|                       | <b>S.D.</b> | 2.16538  | 1156.33319  |
| <b>Total</b>          | <b>Mean</b> | 1.2540   | 1439.0033   |
|                       | <b>N</b>    | 3043   | 3042  |
|                       | <b>S.D.</b> | 1.89142  | 1148.13040  |

\*\*\* Significant at p<.001

~ Differences not statistically significant

**Table 24:**

**Prior Incarcerations**

|                  |              | <b>Recidivism Status</b>  |                    | <b>Total</b> |
|------------------|--------------|---------------------------|--------------------|--------------|
|                  |              | <b>No New<br/>Arrests</b> | <b>New Arrests</b> |              |
| <b>None</b>      | <b>Count</b> | 1998                      | 610                | 2608         |
|                  | <b>%</b>     | 76.6%                     | 23.4%              | 100.0%       |
| <b>1+ priors</b> | <b>Count</b> | 287                       | 148                | 435          |
|                  | <b>%</b>     | 66.0%                     | 34.0%              | 100.0%       |
| <b>Total</b>     | <b>Count</b> | 2285                      | 758                | 3043         |
|                  | <b>%</b>     | 75.1%                     | 24.9%              | 100.0%       |

Significant at p<.001

**Table 25:****Sexual Violence Code**

|              |              | Recidivism Status |             | Total  |
|--------------|--------------|-------------------|-------------|--------|
|              |              | No New Arrests    | New Arrests |        |
| <b>S-3</b>   | <b>Count</b> | 59                | 40          | 99     |
|              | <b>%</b>     | 59.6%             | 40.4%       | 100.0% |
| <b>S-4</b>   | <b>Count</b> | 653               | 359         | 1012   |
|              | <b>%</b>     | 64.5%             | 35.5%       | 100.0% |
| <b>S-5</b>   | <b>Count</b> | 1573              | 359         | 1932   |
|              | <b>%</b>     | 81.4%             | 18.6%       | 100.0% |
| <b>Total</b> | <b>Count</b> | 2285              | 758         | 3043   |
|              | <b>%</b>     | 75.1%             | 24.9%       | 100.0% |

Significant at p&lt;.001

**Table 26:****Release Type**

|                            |              | Recidivism Status |             | Total  |
|----------------------------|--------------|-------------------|-------------|--------|
|                            |              | No New Arrests    | New Arrests |        |
| <b>Direct Discharge</b>    | <b>Count</b> | 1443              | 597         | 2040   |
|                            | <b>%</b>     | 70.7%             | 29.3%       | 100.0% |
| <b>Discharge to Parole</b> | <b>Count</b> | 842               | 161         | 1003   |
|                            | <b>%</b>     | 83.9%             | 16.1%       | 100.0% |
| <b>Total</b>               | <b>Count</b> | 2285              | 758         | 3043   |
|                            | <b>%</b>     | 75.1%             | 24.9%       | 100.0% |

Significant at p&lt;.001

**(5) Could the Outcome Differences be Due to Differing Characteristics Across the Three Study Groups?**

Not only did the offenders differ on a variety of characteristics, some of these characteristics were highly associated with success. The influence of these additional factors must be considered to determine the actual impact of the SOTMP. Also, offenders differ along a continuum in terms of their risk for rearrest. Identifying the extent of the risk and the factors contributing to the likelihood of recidivism allows offenders, the correctional staff and treatment providers to manage risk more effectively.

Like the Kaplan-Meier survival analysis, Cox Proportional Hazards Regression is a method for modeling time-to-event data.<sup>143</sup> Cox Regression also allows the inclusion of predictor variables (or covariates) in the model, similar to a standard regression

<sup>143</sup> Cox, D. R. and Oakes, D. 1984. *Analysis of Survival Data*. London: Chapman and Hall.

*The no treatment and treatment groups differed on measures of prior criminal activity, educational status and ethnicity. To what extent do these characteristics account for the probability of rearrest?*

model.<sup>144</sup> Another benefit of this type of analysis is determining the impact of treatment after taking the influence of other characteristics into account. That is, the impact of treatment can be isolated while characteristics on which the groups varied can be controlled for. As discussed earlier, the no treatment and treatment groups differed on measures of prior criminal activity, educational status and ethnicity. To what extent do these characteristics account for the probability of rearrest?

The exploratory analysis described in the previous section revealed that the following were associated with failure:

- Treatment participation
- Criminal history (prior felony convictions)
- Release type
- Marital status
- Ethnicity
- Age at prison discharge
- Sexual Violence code

Prior felonies and prior incarcerations are both indicators of criminal history, so the single measure of prior incarcerations was selected for further analysis. The outcome measure used in this analysis was new arrests within the first year of release.

*Both Phase 1 and Phase 2 (TC) treatment participation lead to greater success after controlling for the impact of release type, prior incarcerations, age, ethnicity and S-code.*

As presented in Table 27, all of the characteristics except marital status were found to be predictive of new arrests once the others were taken into account.<sup>145</sup> That is, *each* of the remaining characteristics significantly contributed to the likelihood of new rearrest. This analysis verifies that both Phase 1 and Phase 2 (TC) treatment participation lead to greater success after controlling for the impact of release type, prior incarcerations, age, ethnicity and S-code.<sup>146 147</sup>

---

<sup>144</sup> The difference between this method and standard regression modeling is that Cox Regression handles the censored cases while providing estimated coefficients for each of the covariates.

<sup>145</sup> A forward stepwise procedure was used.

<sup>146</sup> The proportional hazards assumption, required for the application of this model, was tested using the stratified method and examining the resulting log minus log plots of the survival function.

<sup>147</sup> The tests of significance applied to these data utilized the Log-Rank, the Breslow and the Tarone-Ware chi-square statistics. Each rendered a significance level of P=.0001.

**Table 27:**

**Characteristics Affecting Outcome: Cox Proportional Hazards Regression Model**

|                            | <b>B</b> | <b>SE</b> | <b>Sig.</b> | <b>Exp(B)</b> |
|----------------------------|----------|-----------|-------------|---------------|
| <b>Released to Parole</b>  | -.490    | .059      | .000        | .613          |
| <b>Prior Incarceration</b> | .467     | .069      | .000        | 1.595         |
| <b>S-Code 3</b>            | .372     | .130      | .004        | 1.451         |
| <b>S-Code 4</b>            | .418     | .058      | .000        | 1.520         |
| <b>Age at Release</b>      | -.034    | .003      | .000        | .967          |
| <b>Hispanic</b>            | .456     | .061      | .000        | 1.578         |
| <b>Black</b>               | .593     | .064      | .000        | 1.810         |
| <b>Phase 1 Treatment</b>   | -.184    | .076      | .015        | .832          |
| <b>Phase 2 Treatment</b>   | -.323    | .109      | .003        | .724          |

***FINDING: The results of the analysis indicate that being placed on parole, prior incarcerations, younger age, having an S-code assignment of S-3 or S-4 and Black or Hispanic ethnicity all influence the likelihood of re-arrest. Further, when these factors are held constant, Phase 1 and Phase 2 (TC) treatment participation increase the likelihood of success.***

An additional benefit of this model, as shown in Table 27, is that the exponent of the regression coefficient (Exp(B)) provides an odds ratio. An odds ratio reflects the relationship between the odds of an outcome (rearrest) for one group compared to the odds of that outcome for another group (no rearrest). When this statistic is 1.0, it means that the odds of success are equivalent for both groups. Compared to the group that remained arrest-free, Table 27 provides the following information regarding risk for failure:

- offenders receiving parole supervision were only 61 percent as likely to be rearrested;
- those with prior incarcerations were at 60 percent greater risk for rearrest;
- being African American increased rearrest risk by 80 percent;
- being Hispanic increased rearrest risk by 60 percent;
- having an S-code of S3 (committing a sex offense while incarcerated) or S4 (factual basis of crime involved a sex offense for which they are not convicted) each increased risk of a new arrest by approximately 50 percent;
- for each additional year of age, risk was reduced 3.3 percent (this adds up to a 33 percent reduction over each decade of advancing age);

Holding each of these characteristics constant, we find that participants in Phase 1 treatment only were 83 percent as likely to be rearrested while participation in both Phase 1 and Phase 2 reduced this risk to 72 percent.

(6) Does Time Spent in Treatment Impact Risk of Re-Offending?

Further analysis indicates that increasing time spent in Phase 2 treatment significantly decreased the risk of rearrest.<sup>148</sup> Here we find that the probability of rearrest drops by 1 percent with each additional month in treatment, or 12 percent per year (each additional month puts an offender at a 99 percent less risk of arrest), as shown in Table 28.

**Table 28:**

**Characteristics Affecting Outcome: Months in TC  
(Phase 2) Treatment**

|                            | <b>B</b> | <b>SE</b> | <b>Sig.</b> | <b>Exp(B)</b> |
|----------------------------|----------|-----------|-------------|---------------|
| <b>Release to Parole</b>   | -.490    | .059      | .000        | .613          |
| <b>Prior Incarceration</b> | .469     | .069      | .000        | 1.598         |
| <b>S-Code 3</b>            | .387     | .129      | .003        | 1.472         |
| <b>S-Code 4</b>            | .432     | .057      | .000        | 1.540         |
| <b>Age at Release</b>      | -.034    | .003      | .000        | .967          |
| <b>Hispanic</b>            | .458     | .061      | .000        | 1.581         |
| <b>Black</b>               | .590     | .064      | .000        | 1.804         |
| <b>Phase 1 Treatment</b>   | -.172    | .075      | .022        | .842          |
| <b>Months in Phase 2</b>   | -.010    | .003      | .003        | .990          |

***FINDING: Increasing time spent in treatment significantly improves offender outcomes. That is, as months spent in treatment increases, so does the probability of success in the community.***

***FINDING: Time spent in Phase 2 significantly contributes to reducing the risk of rearrest. Additionally, duration in treatment may have a greater impact on longer-term outcomes than on short-term outcomes.***

We did additional analyses on time spent in the TC. While the average number of months spent in TC treatment appeared to be correlated with the absence of new arrests in the first year, these differences lacked statistical significance. However, the impact of duration in treatment becomes more visible when examining longer-term outcomes. As shown in Table 29 these differences become more marked and generally reach significance at 2 years and 3 years post-discharge. Note that the relatively small number of cases in this analysis allows us to confidently apply an alpha of .05 to identify group differences.

---

<sup>148</sup> Using the Cox proportional hazards regression technique.

**Table 29:**

**New Arrest by Time in TC Treatment**

| Overall Crimes: New Arrests        |            | Average Months in Treatment | S.D.  | N   | Sig.    |
|------------------------------------|------------|-----------------------------|-------|-----|---------|
| <b>Within 1 year:</b>              | <b>No</b>  | 27.42                       | 29.72 | 249 | NS*     |
|                                    | <b>Yes</b> | 19.26                       | 35.56 | 35  |         |
| <b>Within 2 years:</b>             | <b>No</b>  | 30.10                       | 31.31 | 162 | P=.028* |
|                                    | <b>Yes</b> | 19.94                       | 23.69 | 56  |         |
| <b>Within 3 years:</b>             | <b>No</b>  | 30.10                       | 30.31 | 126 | P=.006* |
|                                    | <b>Yes</b> | 17.48                       | 21.32 | 54  |         |
| <b>Sex Crimes: New Arrests</b>     |            |                             |       |     |         |
| <b>Within 1 year:</b>              | <b>No</b>  | 26.69                       | 29.54 | 278 | NS**    |
|                                    | <b>Yes</b> | 13.53                       | 11.01 | 6   |         |
| <b>Within 2 years:</b>             | <b>No</b>  | 28.29                       | 30.28 | 207 | NS**    |
|                                    | <b>Yes</b> | 12.4                        | 12.26 | 11  |         |
| <b>Within 3 years:</b>             | <b>No</b>  | 27.19                       | 28.89 | 171 | .089**  |
|                                    | <b>Yes</b> | 9.95                        | 7.95  | 9   |         |
| <b>Violent Crimes: New Arrests</b> |            |                             |       |     |         |
| <b>Within 1 year:</b>              | <b>No</b>  | 26.16                       | 29.12 | 271 | NS**    |
|                                    | <b>Yes</b> | 31.72                       | 34.25 | 13  |         |
| <b>Within 2 years:</b>             | <b>No</b>  | 28.65                       | 29.97 | 193 | .009**  |
|                                    | <b>Yes</b> | 18.54                       | 27.65 | 25  |         |
| <b>Within 3 years:</b>             | <b>No</b>  | 27.55                       | 28.46 | 158 | .044**  |
|                                    | <b>Yes</b> | 17.45                       | 27.50 | 22  |         |

\* Analysis of variance used to determine statistical significance.

\*\* Due to the low numbers of new arrests, the non-parametric Mann-Whitney U was used to determine statistical significance

## LIMITATIONS OF THIS RESEARCH

### Sample Bias

The recidivism analysis focused on a sample of sex offenders released from prison over approximately eight years. It is important to remember that prison release cohorts are inherently a less serious group of offenders than, say, an intake or population cohort that include offenders whose crimes warrant life or nearly life sentences. However, any bias that may result from the nature of a release cohort exists equally across both the treatment and non-treatment groups.

Sex offenders in this study self-selected for treatment and there may be important unmeasured differences in personal characteristics among those who chose to engage in treatment compared to those who did not. The extent to which these personal characteristics are related to rearrest remains an important unanswered question.

Phase 1 offenders were significantly more likely to discharge their sentence in prison and not receive parole supervision. During the study period, it was common for sex offenders to waive parole entirely. This practice was ended with the enactment of a mandatory parole law that applied to all cases incarcerated for offenses occurring on or after July 1, 1993.

### Data Available for Analysis

The Colorado Department of Corrections has made considerable advances in the area of offender assessment in recent years. In the mid-1990s, the Department of Corrections began collecting and documenting a variety of assessment data on incoming offenders. Today incoming prisoners receive a battery of assessments for substance and alcohol abuse, educational and vocational needs and personality disorders, and other treatment indicators. The Level of Services Inventory (LSI) was implemented in January of 1995, and the Millon Clinical Multiaxial Inventory (MCMI III) was implemented in July of 1996. Assessments are generally conducted at intake, so only those sex offenders who were admitted to prison after the new assessment procedures were operational received them. Many prisoners in this study left the penitentiary without this information in their files because they entered prison *before* the assessments were incorporated into the intake process. As a result, this information is available on only 20-35 percent (depending on the specific assessment data) of the study group. This 20-35 percent is unlikely to be representative of the release cohorts since only offenders with very short sentences would fall into our release cohort. Additionally, as shown in table 30, the distribution of available assessment data is not consistent across the three groups.



**Table 30:**

**Availability of Data from Specific Assessment Tools**

|          |            | <b>HAS<br/>LSI</b> | <b>HAS<br/>MCMi</b> | <b>TOTAL<br/>N</b> |
|----------|------------|--------------------|---------------------|--------------------|
| No SO Tx | Count<br>% | 900<br>36.5        | 712<br>28.9         | 2465               |
| Phase 1  | Count<br>% | 117<br>21.4        | 89<br>16.23         | 548                |
| Phase 2  | Count<br>% | 112<br>34.5        | 62<br>19.1          | 325                |
| TOTAL    | Count<br>% | 1129<br>35         | 863<br>26.8         | 3338               |

Over time, a greater proportion of the exiting population will have this information available for research, and future studies of this sort will benefit from these rich data. This analysis, however, necessarily relied upon the use of more traditional variables available in the prison data system.

*Recidivism Measures*

The officially recorded recidivism data used in this study underestimate the amount of actual criminal behavior that followed release from prison. Bias introduced from this problem is likely to be evenly distributed across the study groups.

An additional limitation includes the fact that although measures available from official records such as arrests, filings and incarcerations are often used to measure re-offending behavior, such measures are always an under-representation of actual criminal activity and recidivism. This is particularly true when working with the sexual offending population, as many studies verify that victims rarely report this crime (for example, Kilpatrick et al., 1992). For those sex crimes reported to police, not all result in an arrest. Official record data grossly underestimate the actual number of sex crimes, and that remains a limitation for all studies of sex offender recidivism.

Further, the outcome data were limited to events occurring in the State of Colorado. This will not affect the parole revocation analysis, but it underestimates recidivism among those who discharged their sentence and were rearrested in other states since these events will not be captured in the Colorado Crime Information Center data set.

Arrest data are taken from the Colorado Crime Information Center, and only cases in which an arrest is made and fingerprints are taken are included. There is also variation across jurisdictions regarding what crimes and associated case information are captured in arrest data. This could be of particular impact when identifying sex crimes or violent crimes. Therefore, it is anticipated that even greater discrepancies may exist between numbers of arrests and numbers of filings when examining specific types of crimes. For this reason, filing data represents more complete outcome information but it loses arrests that did not result in a court filing by the district attorney.

Lastly, the quality and completeness of CCIC and judicial filing data improved throughout the 1990's, with overall computer system upgrades and advancements in technology, so

the availability of outcome data may not be constant across the study period. Also, the greater awareness and scrutiny of sex offenders throughout the criminal justice system may influence officially recorded case outcomes.

## **SUMMARY**

In summary, the likelihood of remaining arrest free was significantly increased when sex offenders were released onto parole supervision rather than being discharged from prison without the support and structure of parole, and success was significantly further enhanced when sex offenders participated in the SOTMP. Holding group differences constant, treatment combined with parole supervision offered the best probability of remaining arrest-free. Phase 2 participation increased the probability of success beyond participation in only Phase 1. Finally, Phase 2 participants who remained arrest-free averaged 27 to 31 months in TC treatment. Since Phase 2 was available only to those who completed Phase 1, and Phase 1 is a six-month, 4-groups-per-week program, this means that the average time in intense sex offender treatment for those who remained arrest free was an average of 33 to 37 months.

This analysis reflects the value of the SOTMP for reducing the probability of rearrest after release from prison. The program appears to significantly improve offenders' chances of remaining arrest-free upon release from prison. The benefits of treatment appear to be long lasting, as they were observed over the duration of this study's at-risk period (nearly eight years). Offenders with other risk factors, such as prior incarcerations and being young, Black or Hispanic, can use this information to understand and manage the additional risk they face when released to the community. These offenders, in particular, will benefit from the structure of parole supervision and intense community treatment upon release. Also, their chances of remaining arrest-free will increase with more time in TC treatment spent engaging in the group therapy process and working hard in the therapeutic community.

## SECTION SIX: RECOMMENDATIONS

Based on the information collected and analyzed for this study, we make the following recommendations to improve the SOTMP therapeutic community program at the Arrowhead Correctional Center:

### Enhance the Therapeutic Milieu

- Efforts to increase the use of community living as a major intervention method should be prioritized by TC managers. Considerable expertise exists within the TC management to facilitate the use of this powerful method.
- The TC is unlikely to acquire the resources necessary to staff the facility with therapists 24 hours a day, seven days a week. However, increased availability of therapists for one-on-one exchanges with inmates will likely enhance service delivery and offender responsiveness to the program. The TC staff offices are outside the facility perimeter and so it requires a special effort to ensure that therapists are sometimes available to inmates during times other than group sessions. Recent program modifications reflect that the TC managers are developing a requirement for therapists to spend time every week in the living unit. This time is available for individual discussions, “drop – ins” or just touching base with inmates.
- We recommend that once the program is fully staffed again, the TC implements additional changes to facilitate inmate-therapist contact outside of group sessions. We recommend that therapist schedules be made flexible to include evening work hours to facilitate better use of the community setting and reinforce the program philosophy and treatment content in inmates apart from group hours.
- At some point the DOC administration should consider making office and group room space in the living unit to increase formal and informal interaction with inmates and to support the therapeutic milieu. Currently, therapists sit in a corner of the day hall, seeing people as they line up to talk. No privacy exists during these exchanges.
- Training programs and all-staff meetings should include correctional officers, case managers, and DOC work staff from the kitchen and greenhouse to maximize the intervention potential of the TC. Non-treatment staff should observe group sessions and participate in house meetings as their shifts allow. TC staff and DOC administrators should entertain other creative ideas to integrate correctional officers into the TC environment. For instance, perhaps a correctional officer could be trained to co-facilitate a psycho-educational group.
- Cross-training should occur on an annual basis to make sure that all professionals involved in the TC program and facility management understand each others’ needs and expectations for running a safe, therapeutic environment.

### Recognize Inmate Progress in the Program

- Within the restrictions required by a prison environment, TC staff should develop and implement more regular activities and rituals to celebrate positive change and enhance the acknowledgment of inmate progress. These rituals may also provide important motivation for inmates to continue working the program.
- Staff and offenders recognized that forward progress through the five treatment levels in the TC was difficult for inmates to achieve. The lack of movement through the program also had negative impacts for TC participants including those who returned to the general population. TC inmates were discouraged to see each other stay at the same treatment level for long periods of time; many expressed a sense of hopelessness about the possibility of their own progression. Indeed, it is rare for sex offenders to be given a community placement or to receive parole. Therefore, we recommend TC staff continue and expand their recent efforts to redefine and modify the requirements of the treatment levels in the TC, community corrections and parole to provide more opportunities for successful movement through program phases. (Note that offenders are eligible to apply for community placement at the second treatment level.)

### Education/Training Needs

- Although the TC has made many efforts to educate DOC administrators about the difficulty moving inmates through the program, more education needs to be provided. Administrators need information on the following topics:
  - the most difficult issues associated with treating sex offenders, including but not limited to:
    - individual accountability and responsibility are critical program components and require core changes;
    - the difficulties inherent in the change process, including that an individual's treatment progress is seldom linear and consistent in pace;
    - program termination rates are high when individual accountability is a treatment priority,
    - failure to hold individuals accountable will undermine the entire program;
    - the length of time required to make entire lifestyle changes.
  - The unavoidable and natural impact of the job on those who work with this population on a daily basis (including correctional staff, work supervisors, and case managers) and the corresponding need for training.
  - The impact on the program of the competing interests of group and work time.
  - The relapse model (meaning failure is expected).
  - The value of more (not less) time in treatment.
  - The "no cure" nature of sex offending.

- the life long need for treatment and management.
- TC staff would benefit from training specifically targeting group facilitation and facilitator roles for both psycho-educational and process groups and how to include offender participation in both formats. As mentioned earlier, cross training not only for TC clinical staff, but for DOC staff as well, would enhance the therapeutic impact of the 24/7 milieu setting.

### Enhance Some of the Treatment Components

- Case-specific treatment plans should be developed with each offender so that the achievement of therapeutic goals is clearly specified and given expected dates of completion (which will vary across clients). Treatment expectations should be measurable and understood by both the therapist and the program participant. These plans should be comprehensive and individualized. Eliciting offender input, even concerning minor details of treatment, can significantly increase compliance and investment on the part of the client (Meichenbaum and Turk, 1987). Specific goals can structure and guide the individual's performance, focusing attention and involvement on progressing on their specific issues rather than simply the five treatment phases. Individual treatment contacts should address the plan, and regular feedback from the case manager should be incorporated into progress reports. The treatment plan should be a dynamic document that is updated with the offender on an ongoing basis.
- Treatment plans should include strategies to transition the offender to the community.
- Given the disproportionate rearrest rate of non-Anglos, the program should research and then implement culturally appropriate methods of interventions. Since this finding is consistent with outcomes in the drug and alcohol field, and so that literature should be reviewed.

### Process Terminations with Offenders

- Focus group data revealed that inmates who were terminated from the TC had a powerful affect on the remaining members. For some TC participants, the feelings of loss (along with concern that it could happen to them next) appeared to be expressed as anger at what was perceived to be the unjust use of staff power. Because waivers of confidentiality terminate when the case is terminated, TC staff are not free to discuss termination details. To address this issue, the treatment contract was recently modified to permit TC staff to discuss termination reasons with the community when appropriate. Efforts should be made to track this change to determine if it is accomplishing its intent: to address the feelings of failure that "brothers" expressed during focus groups when someone terminates from the program.

### Enhance the Group Process

- If at all possible, conduct meetings in private spaces and not in high activity areas.
- If inevitable schedule changes occur, inform inmates of these adjustments as soon as possible.
- Ensure therapists make better efforts to start and end groups on time or revise the block schedule to more accurately reflect treatment time.

### Increase Program Resources and Quality Assurance Measures

- We recommend that more resources be dedicated to developing sex offense specific evaluations so they can be completed upon intake or shortly thereafter so these can be incorporated into and guide the treatment plan. The sex offender risk assessment scale developed by the ORS on behalf of the Sex Offender Management Board should be one part of the assessment and evaluation process.
- The program has made remarkable efforts to collect and analyze data on the program since the hiring of a researcher in 1996. However, many important data elements remain unreliable (such as reason for program termination and days in Phase I treatment). We recommend that program administrators and staff work with researchers from this study to identify data elements and methods of collection that would be useful in future program evaluations.
- Enhance the ability to implement quality assurance procedures. Supervisors should observe service delivery during group sessions, ensure proper completion of the sanctions grid, review treatment plans, and review community referral documents, but due to staff shortages, only basic services are provided by the program. We recognize that resources are required to ensure program integrity; we recommend developing a quality assurance position for the program when resources become available.
- Many staff would like increased supervision. Scheduled administrative and clinical supervision times, including group observation by supervisors, will improve programming and support program staff.
- Given the increasing numbers of sex offenders currently in prison, and the positive outcomes of those receiving SOTMP services revealed in this study, the CDOC should make expanding treatment resources a priority even in this time of critical budget shortfalls. Public safety requires increasing treatment resources to maximize the number of sex offenders receiving treatment in the CDOC. The social cost of victimization far outweighs the cost of sex offender treatment. Criminal justice policy makers statewide should work together to support the expansion of this program.

## **SUMMARY**

The program evaluation findings reported here reflect the challenges of service delivery in a correctional environment. The SOTMP offers a comprehensive, intense program for Phase 1 offenders: A minimum of six months of psycho-educational group sessions with meetings four times per week. Only those who complete Phase 1 are considered for placement in the TC which offers a living/working environment focused on treatment. One year in the TC should be considered the minimum length of stay with the understanding that each additional year reduces by 12 percent the probability for rearrest. The resources devoted to this effort, combined with the offenders' efforts to change, appear to profoundly improve public safety as measured by officially recorded recidivism. In the face of budget shortfalls, this program should be protected from any further reduction in staff resources and should be a budget priority when state budgets recover from the current economic downturn.

The CDOC is to be applauded for institutionalizing a program that targets a most dangerous offender population for intensive offense-specific treatment delivered according to best practices. The citizens of the state of Colorado are safer because of the effectiveness of the SOTMP.





## REFERENCES

- Akers, R. L. (1977). *Deviant behavior: A social learning approach (2<sup>nd</sup> ed)*. Belmont CA: Wadsworth.
- Antonowicz, D., & Ross, R. R. (1994). Essential components of successful rehabilitation program for offenders. *International Journal of Offender Therapy and Comparative Criminology*, 38, 97-104.
- Association for the Treatment of Sexual Abusers. (2001). *ATSA practice standards and guidelines for members of the association for the treatment of sexual abusers*. Beaverton, OR.
- Baker, D. & Price, S. (1997). Developing therapeutic communities for sex offenders. In Schwartz, B. K. & Cellini, H. R. (eds.). *Sex Offender: New Insights, Treatment Innovations and Legal Developments*, 2, 19-1 to 19-14.
- Bandura, A. (1973). *Aggression: A social learning analysis*. Englewood Cliffs, NJ: Prentice-Hall.
- Beaton, R. & Murphy, S. A. (1995). Working people in crisis: Research implications. In C. R. Figley (Ed.). *Compassion fatigue: Coping with secondary PTSD among those who treat the traumatized*. New York: Bruner Mazel.
- Bouffard, J. A., & Taxman, F. S. (2000). Client gender and the implementation of jail-based therapeutic community programs. *Journal of Drug Issues*, 30(4), 881-900.
- Carich, M. S., Gray, A., Rombouts, S., Stone, M. & Pithers, W. D. (2001). Relapse prevention and the sexual assault cycle. In Carich, M. S. & Mussack, S. E. (Eds.), *Handbook for sexual abuser assessment and treatment*. Brandon, Vermont: Safer Society Foundation, Inc.
- Colorado Department of Corrections. (July, 1985). Sex Offender Treatment Program Plan. Unpublished document made available to researchers by SOTMP staff.
- Colorado Department of Corrections. (2000). *State sex offender treatment programs. 50-state survey*. Prepared for the Colorado Department of Corrections by Paula Wenger, Colorado Springs, Colorado. Available at <http://www.doc.state.co.us/programs.htm>.
- Colorado Department of Corrections. (May, 2003). Monthly project status reports. Unpublished documents made available to researchers by SOTMP staff.
- Colorado Department of Corrections. Overview of the FY 2003-04 general fund budget request. Available at [http://www.state.co.us/gov\\_dir/govnr/dir/ospb/governorsbudget/fy2003-04/govbudgethighlights03-04.pdf](http://www.state.co.us/gov_dir/govnr/dir/ospb/governorsbudget/fy2003-04/govbudgethighlights03-04.pdf) (p.11).
- Colorado Coalition Against Sexual Assault. (1998). *Sexual assault in Colorado: Results of a 1998 statewide survey*. Colorado Department of Public Health and Environment. Denver, Colorado. Available at [www.ccasa.org/publications/index.cfm/reports](http://www.ccasa.org/publications/index.cfm/reports).

Colorado Sex Offender Management Board. (1999r). *Standards and guidelines for the assessment, evaluation, treatment and behavioral monitoring of adult sex offenders*. Denver, Colorado: Colorado Division of Criminal Justice.

Cornish, D. B., & Clarke, R. V. G. (Eds.). (1986). *The reasoning criminal: Rational choice perspectives on crime*. New York: Springer-Verlag.

Cox, D. R. & Oakes, D. (1984). *Analysis of survival data*. London: Chapman and Hall.

Crick, N. R., & Dodge, K. A. (1994). A review and reformulation of social information-processing mechanisms in children's social adjustment. *Psychological Bulletin*, 115, 74-101.

De Leon, G. (1995). Therapeutic communities for addictions: A theoretical framework. *International Journal of the Addictions*, 30, 1603-1645.

De Leon, G. (2000). *The therapeutic community: Theory, model, and method*. New York: Springer Publishing Co.

English, K., Pullen, S., & Jones, L. (Eds.). (1996). *Managing adult sex offenders: A containment approach*. Lexington, KY: American Probation and Parole Association.

English, K. & Woodburn, S. (2002). *Community corrections in Colorado: A report of findings*. Denver: Colorado Department of Public Safety, Division of Criminal Justice, Office of Research and Statistics.

Fernandez, Y. M. & Marshall, W. L. (2003). Victim empathy, social self-esteem and psychopathy in rapists. *Sexual Abuse: A Journal of Research and Treatment*, 15 (5), 11-26.

Field, G. (1989). The effects of intensive treatment on reducing the criminal recidivism of addicted offenders. *Federal Probation*, 53(4), 51-56.

Freeman-Longo, R., & Knopp, F. H. (1992). State of the art sex offender treatment: Outcomes and issues. *Annals of Sex Research*, 5, 141-160.

Hall, G. C. N. (1995). Sexual offender recidivism revisited: A meta-analysis of recent treatment studies. *Journal of Consulting and Clinical Psychology*, 63, 802-809.

Hanson, Glen R. (2002). Director's notes: In drug abuse, gender matters. *NIDA Notes*, 17(2), 3-4.

Hanson, R. K. (1992). Relationship questionnaire. Unpublished test. Ottawa Ministry Secretariat, Solicitor General Canada.

Hanson, R. K. (1995). Empathy for women test, version 2. Unpublished test. Ottawa Ministry Secretariat, Solicitor General Canada.

Hanson, R. K. (1999). Child empathy test, version 2. Unpublished test. Ottawa Ministry Secretariat, Solicitor General Canada.

Herman, J. L. (1990). Sex offenders: A feminist perspective. In Marshall, W.L., Laws, D. R., & Barbaree, H. E. (eds.). *Handbook of sexual assault: Issues, theories, and treatment of the offender*. New York: Plenum Press.

Hildebran, D. & Pithers, W. D. (1989). Enhancing offender empathy for sexual-abuse victims. In D. R. Laws (Ed.). *Relapse prevention with sex offenders*, 236-243. New York: Guilford.

Hubbard, R. L. (1997). Overview of 1-year follow-up outcomes in the drug abuse treatment outcome study (DATOS). *Psychology of Addictive Behaviors*, 11, 261-278

Inciardi, J. A., Martin, S. S., Butzin, C. F., Hooper, R. M., & Harrison, L. D. (1997). An effective model of prison-based treatment for drug-involved offenders. *Journal of Drug Issues*, 27, 261-278.

Kilpatrick, D.G., Edmunds, C. N., and Seymore, A. (1992). *Rape in America: Report to the Nation*. Charleston: Medical Unit of South Carolina and the Crime Victims Research Center.

Knapp, M. (1996). Treatment of sex offenders. In English, K., Pullen, S., & Jones, L. (Eds.). In *Managing adult sex offenders: A containment approach*. Lexington, KY: American Probation and Parole Association.

Knight, K., Simpson, D. D., Chatham, L. R., & Camacho, L. M. (1997). An assessment of prison-based drug treatment: Texas in-prison therapeutic community program. *Journal of Offender Rehabilitation*, 24, 75-100.

Lee, E. T. (1992). *Statistical methods for survival data analysis (2<sup>nd</sup> ed.)*. New York: John Wiley & Sons.

Lefcourt, H. M. (1991). Balance inventory of desirable responding. *Measures of personality and social psychological attitudes*. New York: Academic Press Inc.

Lefcourt, H. M. (1991). Internal-external locus of control scale. *Measures of personality and social psychological attitudes*. New York: Academic Press Inc.

Lipton, D. S. (1998). Therapeutic community treatment programming in corrections. *Psychology, Crime, & Law*, 4, 213-263.

Lipton, D. S. (2002). *The effectiveness of correctional interventions*. Presentation at the Annual NIJ/BJA Research and Evaluation Conference. Washington D.C. National Institute of Justice.

Lipton, D. S., Pearson, F. S., Cleland, C. M., & Yee, D. (2002). The effects of therapeutic communities and milieu therapy on recidivism: Meta-analytic findings from the correctional drug abuse treatment effectiveness (CDATE) study. In Mc Guire, J. (Ed.). *Offender Rehabilitation and Treatment: Effective Programmes and Policies to Reduce Re-offending*. New York: John Wiley & Sons, Ltd.

Loss, P. (2001). The sex abuser treatment group process. In Carich, M. S. & Mussack, S.E. (Eds.). *Handbook for sexual abuser assessment and treatment*. Brandon, Vermont: Safer Society Foundation, Inc.

Lowe, G. (2001). Program development: Key elements and staff management. In Carich, M. S. & Mussack, S.E. (Eds.), *Handbook for sexual abuser assessment and treatment*. Brandon, Vermont: Safer Society Foundation, Inc.

MacKenzie, D. L. & Hickman, L. J. (1998). *What works in corrections: An examination of the effectiveness of the type of rehabilitation programs offered by Washington State Department of Corrections*. University of Maryland, Department of Criminology and Criminal Justice, Crime Prevention Effectiveness Program.

Marshall, W. L. (1994). Treatment effects on denial and minimization in incarcerated sex offenders. *Behavior Research and Therapy*, 32, 449-564.

Marshall, W.L., Laws, D.R. & Barbaree, H. E. (Eds.). (1990). *Handbook of sexual assault: Issues, theories, and treatment of the offender*. New York: Plenum Press.

Marshall, W. L. & Williams, S. (1998). Assessment and treatment of sexual offenders. *Correctional Treatment*, 41-44.

Martin S. S., Butzin, C. A., Saum, C. A. & Inciardi, J. A. (1999). Three year outcomes of therapeutic community treatment for drug-involved offenders in Delaware: From prison to work release to aftercare. *The Prison Journal*, 79(3), 294-320.

Meichenbaum, D. & Turk, D. (1987). *Facilitating treatment adherence: A practitioner's guidebook*. New York: Plenum Press.

Millon, T. (1994). *Manual for the MCMI-III*. Minneapolis, MN: National Computer Systems.

Morey, L. C. (1991). *Personality assessment inventory*. Odessa, FL: Psychological Assessment Resources, Inc.

Musack, S. E. & Carich, M. S. (Eds.). (2001). *Handbook for sexual abuser assessment and treatment*. Brandon, Vermont: Safer Society Press.

National Institute on Drug Abuse. (August, 2002). Research Report Series, Therapeutic Communities. NIDA Publication Number 02-4877. Washington, D.C.: U.S. Department of Health and Human Services, National Institutes of Health.

Nichols, H. R., & Molinder, L. (1996). *Multiphasic sex inventory handbook*. Tacoma, WA: Nichols and Molinder Assessments.

O'Keefe, M. L., Lebe, K. J. & Timken, D. (2001). *Group Process Measure*, Unpublished test. Colorado Springs, Colorado Department of Corrections.

Peebles, J. E. (1999). Therapeutic jurisprudence and the sentencing of sexual offender in Canada. *International Journal of Offender Therapy and Comparative Criminology*, 43(3), 275-290.

Polizzi, D. M., MacKenzie, D. L., & Hickman, L. J. (1999). What works in adult sex offender treatment? A review of prison- and non-prison based treatment programs. *International Journal of Offender Therapy and Comparative Criminology*, 43(3), 357-374.

Prendergast, M., Farabee, D., & Cartier, J. (2001). The impact of in-prison therapeutic community programs on prison management. *Journal of Offender Rehabilitation*, 32(3), 63-78.

Przybylski, R. & English, K. (1996). Evaluating sex offender programs. In English, K., Pullen, S., & Jones, L. (Eds.). In *Managing adult sex offenders: A containment approach*. Lexington, KY: American Probation and Parole Association.

Pullen, C. & Pullen, S. (1996). Secondary trauma associated with managing sex offenders. In *Managing adult sex offenders: A containment approach*. Lexington, KY: American Probation and Parole Association.

Rockholtz, Peter B. (2002). National update on therapeutic community programs for substance abusing offenders in state prisons, *Offender Substance Abuse Report*, 2(4), 49-64.

Salter, A. C. (1988). *Treating child sex offenders and victims*. Thousand Oaks, CA: Sage.

Salter, A. C. (1995). *Transforming trauma: A guide to understanding and treating adult survivors of child sexual abuse*. Thousand Oaks, CA: Sage.

Sex Offender Treatment and Monitoring Program. (no date provided). Inmate sex offender treatment costs. Unpublished document made available to researchers by SOTMP staff. Canon City: Colorado Department of Corrections.

Sex Offender Treatment and Monitoring Program. (January, 2001r). *Sex offenders: Myths, facts and treatment: A community outreach project and resource guide*. Canon City: Colorado Department of Corrections.

Sex Offender Treatment and Monitoring Program. (July, 2000r). Therapeutic Community Polygraph Grid Form. Unpublished document. Canon City: Colorado Department of Corrections.

Sex Offender Treatment and Monitoring Program (SOTMP). (Continually updated). Therapeutic Community Program Manual. Vols. 1 and 2. Unpublished document. Canon City: Colorado Department of Corrections.

Alaska Statistical Analysis Center and the Alaska Department of Corrections. (August 1996). *Sex Offender Treatment Program: Initial recidivism study*. Anchorage: University of Alaska. Executive Summary available at: <http://www.uaa.alaska.edu/just/publications/9602sotp.html>.

Shapiro, B. (2001). The therapeutic community movement in corrections. *Corrections Today*, 63(1), 24-26.

Simpson, D. D., Wexler, H. & Inciardi, J. (1999). The introduction. *The Prison Journal*, 79(4), 381-383.

Snyder, H. N. (2000). *Sexual assault of young children as reported to law enforcement: Victim, incident, and offender characteristics*. Office of Justice Programs, Bureau of Justice Statistics. Washington, D.C.: US Department of Justice.

Sutherland, E. H. (1947). *Principles of criminology* (4<sup>th</sup> ed.). Philadelphia, PA: Lippincott.

Therapeutic Communities of America (TCA). (1999). *Therapeutic communities in correctional settings: The prison based TC standards development project*. Final report of phase II. Washington, D.C.: White House Office of National Drug Control Policy. Available at [http://www.whitehousedrugpolicy.gov/national\\_assembly/publications/therap\\_comm/ther\\_9.htm](http://www.whitehousedrugpolicy.gov/national_assembly/publications/therap_comm/ther_9.htm).

Thomas, J. & Viar, C. W. (2001). Family treatment of adult sexual abusers. In Carich, M. S. & Mussack, S.E. (Eds.). *Handbook for Sexual Abuser Assessment and Treatment*. Brandon, Vermont: Safer Society Foundation, Inc.

Van der Kolk, B. A., McFarlane, A. C., & Weisaeth, L. (Eds.). (1996). *Traumatic stress: The effects of overwhelming experience on mind, body, and society*. New York, NY: The Guilford Press.

Wexler, H. K., Falkin, G. P., & Lipton, D. S. (1988). *A model prison rehabilitation program: An evaluation of the "Stay'n Out" therapeutic community*. Final Report to the National Institute on Drug Abuse. Washington D.C.: U.S. Department of Health and Human Services, National Institutes of Health.

Wexler, H. K., Falkin, G. P., & Lipton, D. S. (1990). Outcome evaluation of a prison therapeutic community for substance abuse treatment. *Criminal Justice & Behavior*, 17, 71-92.

Wexler, H. K. (2000). Criminal justice aftercare: An integrated approach. *The Counselor* July/August, 30-34.

Winick, B. J. (1991). Competency to consent to voluntary hospitalization: A therapeutic jurisprudence analysis of *Zinermon v. Burch*. *International Journal of Law and Psychiatry*, 14, 169-214

**APPENDICES A – R:  
CAN BE FOUND IN THE NEXT DOCUMENT**